

Engineering Data

Compact Four-way Cassette VRF IDU

AC 50Hz

Atom Series



MDV-D05Q4/N1-A3(At)

MDV-D12Q4/N1-A3(At)

MDV-D07Q4/N1-A3(At)

MDV-D15Q4/N1-A3(At)

MDV-D09Q4/N1-A3(At)

Compact Four-way Cassette

1 Specifications	4
2 Dimensions	6
3 Unit Placement	7
4 Piping Diagram	9
5 Wiring Diagram	10
6 Capacity Tables.....	12
7 Electrical Characteristics.....	13
8 Sound Levels	14

1 Specifications

MDV-D05Q4/N1-A3(At) / MDV- D07Q4/N1-A3(At) / MDV- D09Q4/N1-A3(At)

Table 1.1: MDV-D05(07, 09)Q4/N1-A3(At) specifications

Model			MDV-D05Q4/N1-A3(At)	MDV-D07Q4/N1-A3(At)	MDV-D09Q4/N1-A3(At)
Power supply			1 phase, 220-240V, 50Hz		
Cooling ¹	Capacity	kBtu/h	5	7	9
	Input	W	36	50	50
Heating ²	Capacity	kBtu/h	5	8	10
	Input	W	36	50	50
Indoor fan motor	Type		AC motor		
	Quantity		1		
Indoor coil	Number of rows		1		
	Tube pitch × row pitch	mm	21×13.37		
	Fin spacing	mm	1.3		
	Fin type		Hydrophilic aluminum		
	Diameter & type	mm	Φ7, inner-groove		
	Dimensions (L×H×W)	mm	1310×210×13.37		
	Number of circuits		1	2	2
Air flow rate (H/M/L)		m ³ /h	400/283/208	414/313/238	414/313/238
Sound pressure level (H/M/L) ³		dB(A)	35/33/23	36/33/23	36/33/23
Indoor unit	Dimensions ⁴ (W×H×D)	mm	570×260×630		
	Packing (W×H×D)	mm	675×285×675		
	Net/Gross weight	kg	17/20	17/20	17/20
Panel	Dimensions (W×H×D)	mm	647×50×647		
	Packing(W×H×D)	mm	715×123×715		
	Net/Gross weight	kg	2.5/4.5		
Refrigerant type			R410A		
Pipe connections	Liquids pipe	mm	Φ6.35		
	Gas pipe	mm	Φ12.7		
	Drain pipe	mm	OD Φ25		

Notes:

- Indoor temperature 27°C DB, 19°C WB; outdoor temperature 35°C DB; equivalent refrigerant piping length 7.5m with zero level difference.
- Indoor temperature 20°C DB; outdoor temperature 7°C DB, 6°C WB; equivalent refrigerant piping length 7.5m with zero level difference.
- Sound pressure level is measured 1.4m below the unit in a semi-anechoic chamber.
- Unit body dimensions given are the largest external dimensions of the unit, including hanger attachments.

MDV- D12Q4/N1-A3(At) / MDV- D15Q4/N1-A3(At)

Table 1.2: MDV-D12(15)Q4/N1-A3(At) specifications

Model			MDV-D12Q4/N1-A3(At)	MDV-D15Q4/N1-A3(At)
Power supply			1 phase, 220-240V, 50Hz	
Cooling ¹	Capacity	kBtu/h	12	15
	Input	W	56	56
Heating ²	Capacity	kBtu/h	13	17
	Input	W	56	56
Indoor fan motor	Type		AC motor	
	Quantity		1	
Indoor coil	Number of rows		2	2
	Tube pitch × row pitch	mm	21×13.37	
	Fin spacing	mm	1.3	
	Fin type		Hydrophilic aluminum	
	Diameter & type	mm	Φ7, inner-groove	
	Dimensions (L×H×W)	mm	1310×210×26.74	
	Number of circuits		4	
Air flow rate (H/M/L)	m ³ /h		521/409/314	521/409/314
Sound pressure level (H/M/L) ³	dB(A)		42/36/29	42/36/29
Indoor unit	Dimensions ⁴ (W×H×D)	mm	570×260×630	
	Packing (W×H×D)	mm	675×285×675	
	Net/Gross weight	kg	18.5/21.5	
Panel	Dimensions (W×H×D)	mm	647×50×647	
	Packing(W×H×D)	mm	715×123×715	
	Net/Gross weight	kg	2.5/4.5	
Refrigerant type			R410A	
Pipe connections	Liquids pipe	mm	Φ6.35	
	Gas pipe	mm	Φ12.7	
	Drain pipe	mm	OD Φ25	

Notes:

1. Indoor temperature 27°C DB, 19°C WB; outdoor temperature 35°C DB; equivalent refrigerant piping length 7.5m with zero level difference.
2. Indoor temperature 20°C DB; outdoor temperature 7°C DB, 6°C WB; equivalent refrigerant piping length 7.5m with zero level difference.
3. Sound pressure level is measured 1.4m below the unit in a semi-anechoic chamber.
4. Unit body dimensions given are the largest external dimensions of the unit, including hanger attachments.

2 Dimensions

2.1 Unit Dimensions

Figure 2.1: Compact Four-way Cassette dimensions (unit: mm)

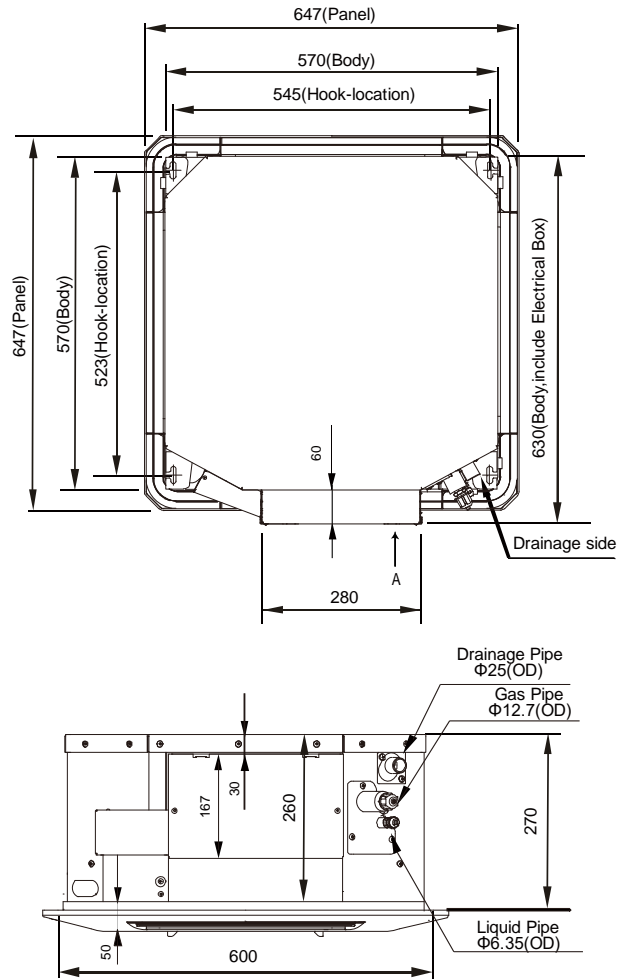

3 Unit Placement

3.1 Placement Considerations

Unit placement should take account of the following considerations:

- Units should not be installed in the following locations:
 - Where exposure to direct radiation from a high-temperature heat source or to interference from a source of electromagnetic radiation may occur.
 - Where dust or dirt may affect heat exchangers.
 - Where exposure to oil or to corrosive or harmful gases, such as acidic or alkaline gases, may occur.
 - Where exposure to salinity may occur, such as seaside locations.
 - Where highly flammable materials are present.
 - Where exposure to oily air may occur, such as a kitchen.
 - Where exposure to very high humidity may occur, such as a laundry.
- Units should be installed in positions where:
 - The ceiling is horizontal and is able to bear the unit's weight.
 - There are no obstructions that could impede the airflow into and out of the unit.
 - The airflow out of the unit can reach throughout the room.
 - There is sufficient space for access during installation, servicing and maintenance.
 - The refrigerant piping and drain piping can be easily connected to the refrigerant piping and drain piping systems.
 - Short-circuit ventilation (where outlet air returns quickly to a unit's air inlet) will not occur.

3.2 Space Requirements

Figure 3.1: Compact Four-way Cassette space requirements (unit: mm)

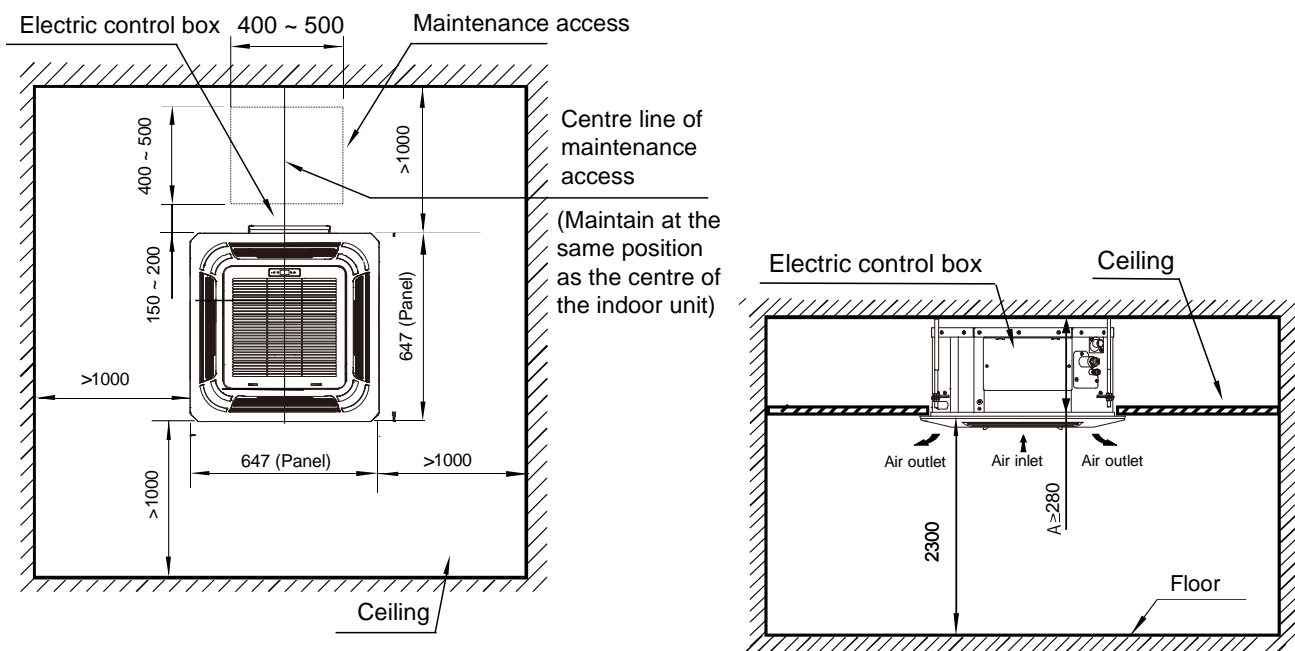

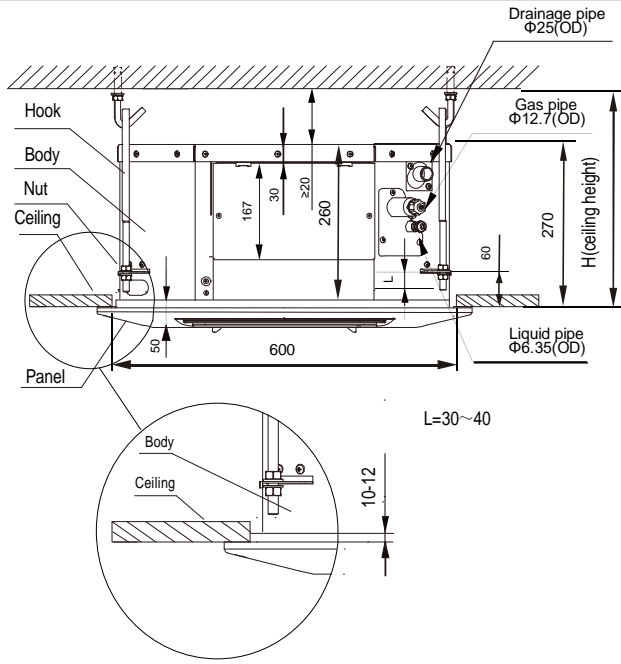

Notes:

1. The centerline of the maintenance hole should be in the same position as the centerline of the indoor unit.

4 Piping Diagram

Figure 4.1: Compact Four-way Cassette piping diagram

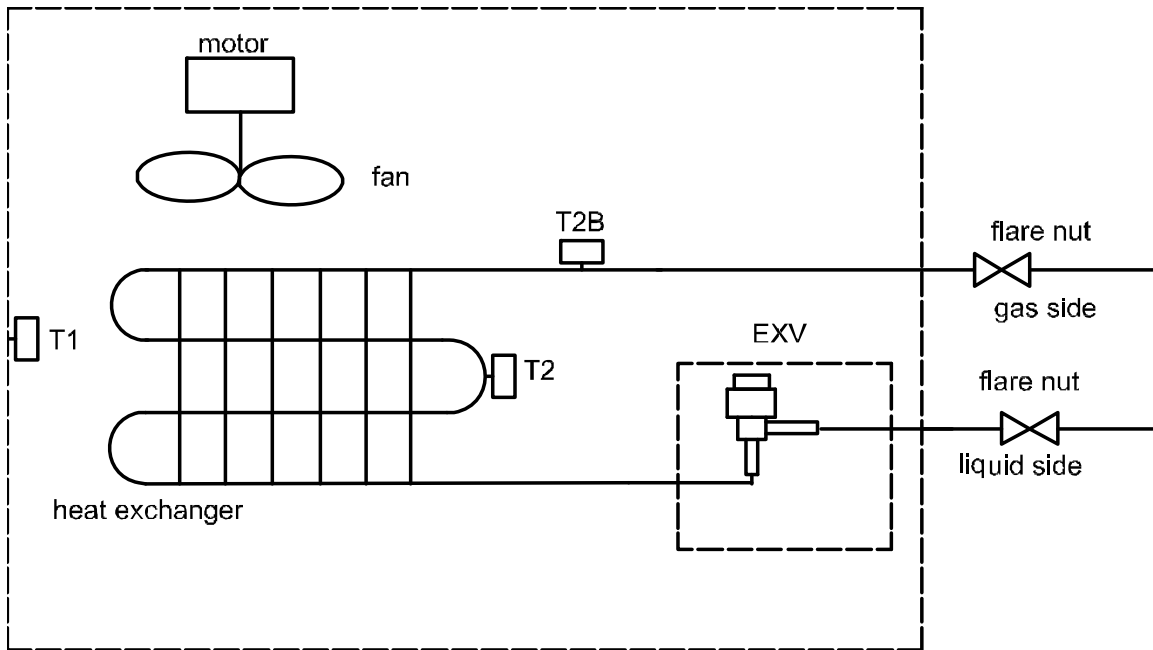

Legend	
T1	Indoor ambient temperature sensor
T2	Indoor heat exchanger mid-point temperature sensor
T2B	Indoor heat exchanger outlet temperature sensor

Atom Series VRF Indoor Units



5 Wiring Diagram

Figure 5.1: Compact Four-way Cassette piping diagram wiring diagram

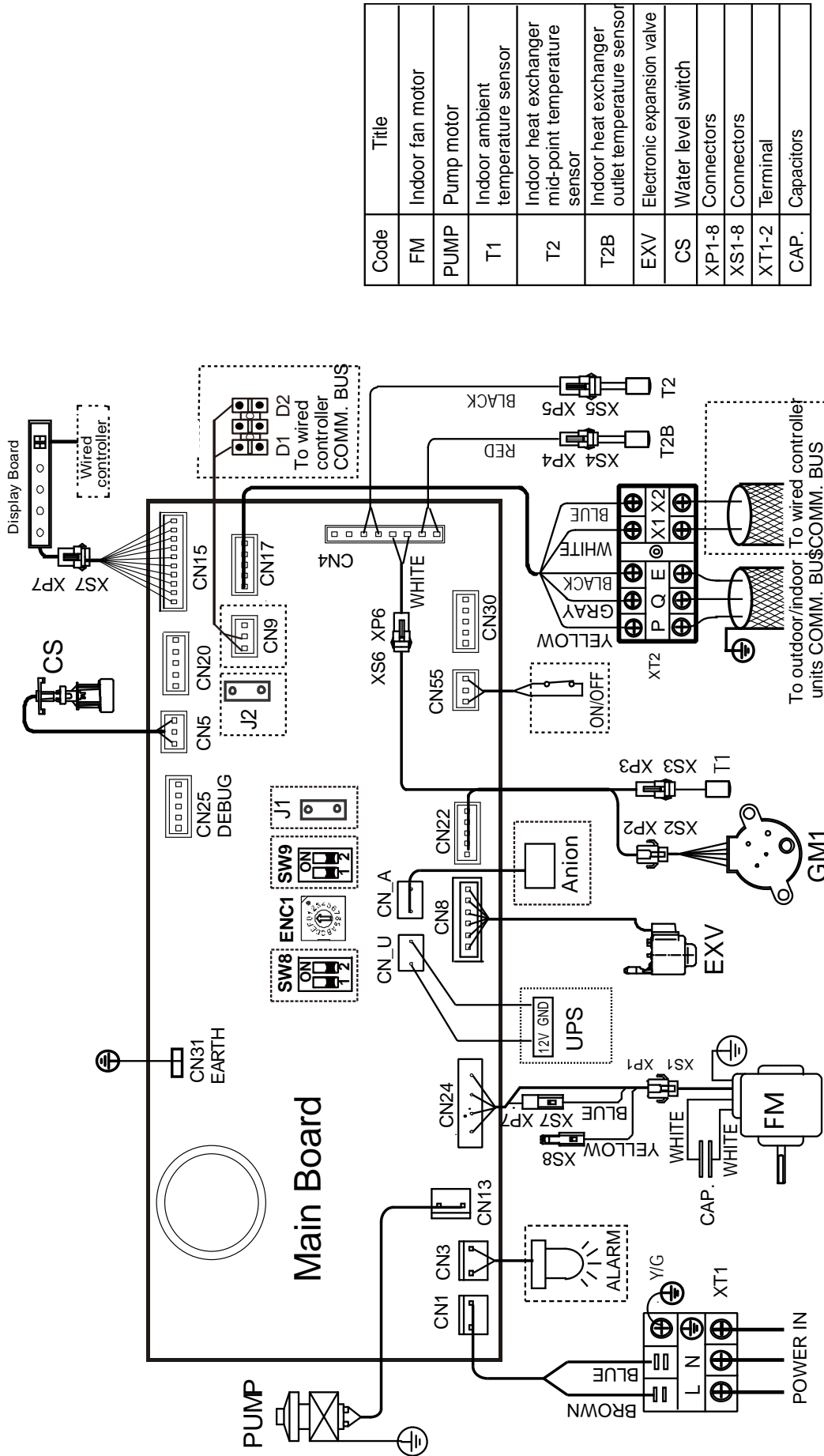

Code	Title
FM	Indoor fan motor
PUMP	Pump motor
T1	Indoor ambient temperature sensor
T2	Indoor heat exchanger mid-point temperature sensor
T2B	Indoor heat exchanger outlet temperature sensor
EXV	Electronic expansion valve
CS	Water level switch
XP1-8	Connectors
XS1-8	Connectors
XT1-2	Terminal
CAP.	Capacitors

Notes for installers and service engineers **Caution**

- All installation, servicing and maintenance must be carried out by competent and suitably qualified, certified and accredited professionals and in accordance with all applicable legislation.
- Units should be grounded in accordance with all applicable legislation. Metal and other conductive components should be insulated in accordance with all applicable legislation.
- Power supply wiring should be securely fastened at the power supply terminals – loose power supply wiring would represent a fire risk.
- After installation, servicing or maintenance, the electric control box cover should be closed. Failing to close the electric control box cover risks fire or electric shock.
- Switch ENC1 (indoor unit capacity setting) is factory-set and its setting should normally not be changed. The only circumstances in which a switch ENC1 might need to be set in the field is when replacing a main PCB. When replacing a main PCB, ensure that the capacity setting on switch ENC1 on the new PCB is consistent with the unit capacity given on the unit's nameplate.

6 Capacity Tables

6.1 Cooling Capacity Table

Table 6.1: Compact Four-way Cassette cooling capacity

Model	Indoor air temperature (°C WB/DB)													
	14/20		16/23		18/26		19/27		20/28		22/30		24/32	
	TC	SC	TC	SC	TC	SC	TC	SC	TC	SC	TC	SC	TC	SC
MDV-D05Q4/N1-A3(At)	1.4	1.4	1.5	1.4	1.5	1.3	1.5	1.3	1.6	1.3	1.6	1.2	1.6	1.1
MDV-D07Q4/N1-A3(At)	2.0	2.0	2.1	1.9	2.2	1.9	2.2	1.8	2.3	1.8	2.3	1.7	2.4	1.7
MDV-D09Q4/N1-A3(At)	2.5	2.5	2.7	2.5	2.8	2.4	2.8	2.3	2.9	2.3	2.9	2.2	3.0	2.1
MDV-D12Q4/N1-A3(At)	3.2	3.0	3.4	3.0	3.6	3.1	3.6	2.9	3.7	2.9	3.8	2.8	3.9	2.7
MDV-D15Q4/N1-A3(At)	4.0	3.8	4.3	3.8	4.5	3.8	4.5	3.7	4.6	3.6	4.7	3.4	4.8	3.3

Abbreviations:

TC: Total capacity (kW)

SC: Sensible capacity(kW)

Notes:

1. Shaded cells indicate rating condition.

6.2 Heating Capacity Table

Table 6.2: Compact Four-way Cassette heating capacity

Model	Indoor air temperature (°C DB)					
	16	18	20	21	22	24
	TC	TC	TC	TC	TC	TC
MDV-D05Q4/N1-A3(At)	1.8	1.8	1.7	1.6	1.6	1.5
MDV-D07Q4/N1-A3(At)	2.6	2.6	2.4	2.3	2.3	2.1
MDV-D09Q4/N1-A3(At)	3.4	3.4	3.2	3.1	3.0	2.8
MDV-D12Q4/N1-A3(At)	4.2	4.2	4.0	3.8	3.8	3.5
MDV-D15Q4/N1-A3(At)	5.3	5.3	5.0	4.8	4.7	4.4

Abbreviations:

TC: Total capacity (kW)

Notes:

1. Shaded cells indicate rating condition.

7 Electrical Characteristics

Table 7.1: Compact Four-way Cassette electrical characteristics

Model name	Power supply						Indoor fan motors	
	Hz	Volts	Min. volts	Max. volts	MCA	MFA	Rated motor output (kW)	FLA
MDV-D05Q4/N1-A3(At)	50	220-240	198	264	0.2	15	0.05	0.16
MDV-D07Q4/N1-A3(At)	50	220-240	198	264	0.2	15	0.05	0.16
MDV-D09Q4/N1-A3(At)	50	220-240	198	264	0.2	15	0.05	0.16
MDV-D12Q4/N1-A3(At)	50	220-240	198	264	0.3	15	0.056	0.24
MDV-D15Q4/N1-A3(At)	50	220-240	198	264	0.3	15	0.056	0.24

Abbreviations:

MCA: Minimum Circuit Amps

MFA: Maximum Fuse Amps

FLA: Full Load Amps

8 Sound Levels

8.1 Overall

Table 8.1: Compact Four-way Cassette sound pressure levels¹

Model name	Sound pressure levels dB(A)		
	H	M	L
MDV-D05Q4/N1-A3(At)	35	33	23
MDV-D07Q4/N1-A3(At)	36	33	23
MDV-D09Q4/N1-A3(At)	36	33	23
MDV-D12Q4/N1-A3(At)	42	36	29
MDV-D15Q4/N1-A3(At)	42	36	29

Notes:

1. Sound pressure levels are measured 1.4m below the unit in a semi-anechoic chamber. During in-situ operation, sound pressure levels may be higher as a result of ambient noise.

Figure 8.1: Compact Four-way Cassette sound pressure level measurement

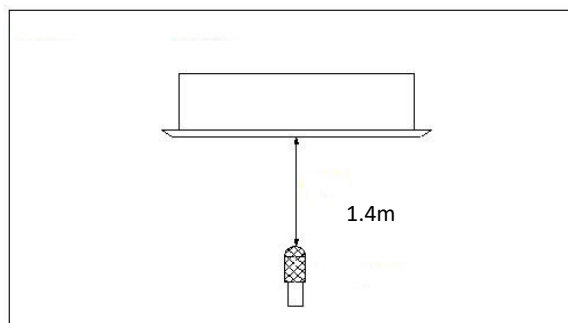

8.2 Octave Band Levels

Figure 8.2: MDV-D05Q4/N1-A3(At) octave band levels

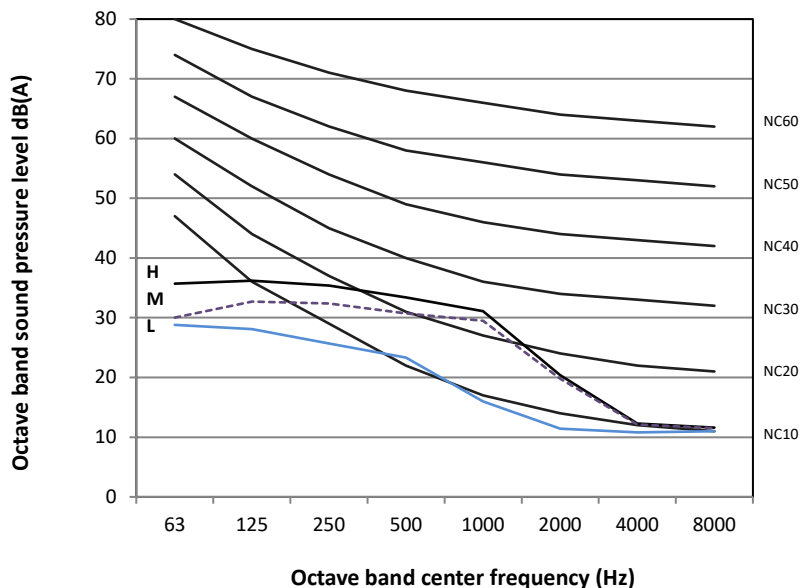

Figure 8.3: MDV-D07(09)Q4/N1-A3(At) octave band levels

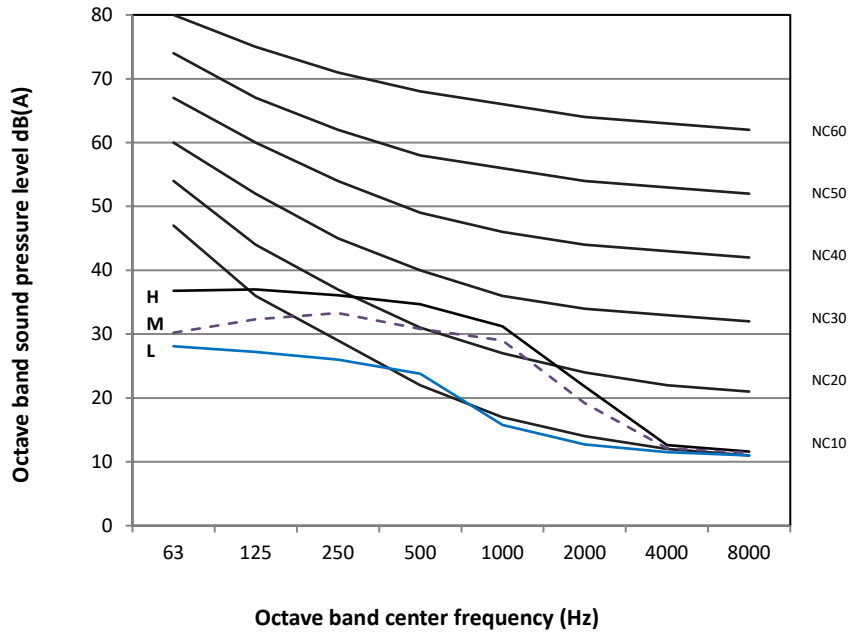

Figure 8.4: MDV-D12(15)Q4/N1-A3(At) octave band levels

