

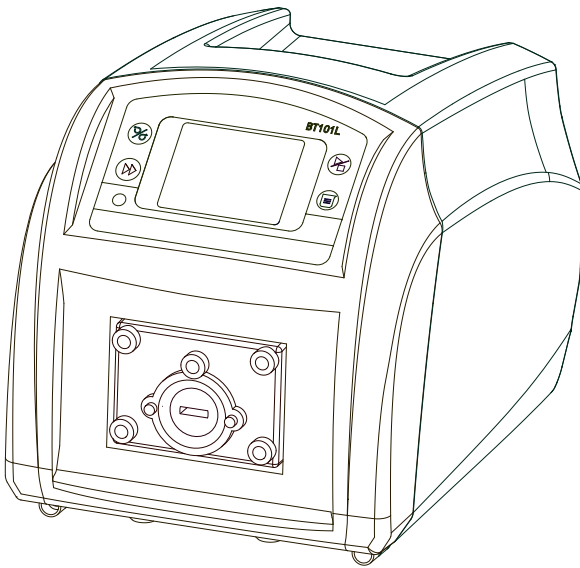

Intelligent Flow Peristaltic Pump

Operating Manual

For BT101L, BT301L, BT601L



Contents

Safety Precautions	1
1 Description	6
2 Functions and Features.....	6
3 Components and Connectors.....	8
4 Display Panel and Operating Keypads	9
4.1 Keypad.....	9
4.2 LCD Touch Screen Display.....	10
4.3 System Settings	14
5 External Control Interface.....	21
6 Operation Instructions	22
6.1 Before Operation.....	22
6.2 Power Connection.....	22
6.3 First Run Wizard	22
6.4 Flow Rate Calibration	23
6.5 Run Wizard	26
6.6 Easy Dispense Mode	28
6.7 External Control Mode.....	29
6.8 Communication Mode	32
6.9 Footswitch.....	33
7 Maintenance	34
7.1 Warranty.....	34
7.2 Regular Maintenance	34
7.3 Malfunction Solutions	35
8 Dimensions	37
9 Naming Rule	37
10 Specifications.....	38

Safety Precautions



Danger

- Use the correct voltage indicated on the rating plate label of the pump to avoid any damage.
- Do not make any unauthorized dismantling, changes or modifications to the pump which could result in malfunctions or even potential accidents.
- Turn off the pump drive before installing or removing tubing, attempting any maintenance, cleaning or repair of the drive, connecting or disconnecting external control devices or a communication interface. Fingers or loose clothing could get caught in the drive mechanism.



Warning

- Ensure no chemical reactions occur between the handled fluid with the material of the pump head and tubing before use.
- Tubing should be checked regularly to avoid breakage. Tubing breakage may result in fluid being sprayed from the pump. Use appropriate measures to protect the operator and equipment. The operator is solely liable for damages resulting from tubing breakage, particularly the leakage of toxic or valuable liquids.
- The pump is provided with a grounded plug which must be well grounded at all times.
- This device is not designed for nor intended for usage in patient connected applications, including but not limited to medical and dental use.
- Observe all other applicable regulations concerning working safety, operational safety, environmental protection and relevant local regulations.

(DE) SICHERHEITSHINWEISE



Gefahr

- Verwenden Sie die richtige Spannung, die auf dem Typenschild der Pumpe angegeben ist, um Schäden zu vermeiden.
- Nehmen Sie keine unbefugten Demontagen, Änderungen oder Modifikationen an der Pumpe vor, die zu Fehlfunktionen oder sogar zu Unfällen führen könnten.
- Schalten Sie den Pumpenantrieb aus, bevor Sie Schläuche ein- oder ausbauen, Wartungs-, Reinigungs- oder Reparaturarbeiten am Antrieb vornehmen oder externe Steuergeräte oder eine Kommunikationsschnittstelle anschließen oder trennen. Finger oder lose Kleidungsstücke können sich im Antriebsmechanismus verfangen.



Warnung

- Vergewissern Sie sich vor der Verwendung, dass keine chemischen Reaktionen zwischen dem Fördermedium und dem Material des Pumpenkopfs und der Schläuche auftreten können.
- Die Schläuche sollten regelmäßig überprüft werden, um Brüche zu vermeiden. Ein Schlauchbruch kann dazu führen, dass Flüssigkeit aus der Pumpe spritzt. Ergreifen Sie geeignete Maßnahmen zum Schutz des Bedieners und der Ausrüstung. Der Betreiber haftet allein für Schäden, die durch einen Schlauchbruch entstehen, insbesondere für das Austreten von giftigen oder wertvollen Flüssigkeiten.
- Die Pumpe ist mit einem geerdeten Stecker ausgestattet, der stets korrekt an eine abgesicherte Netzsteckdose angeschlossen sein muss. Dieses Gerät ist nicht für Anwendungen ausgelegt oder vorgesehen, die im Zusammenhang mit der Behandlung von Patienten stehen. Medizinische bzw. zahnmedizinische Anwendungen sind nicht bestimmungsgemäß.
- Beachten Sie alle anderen geltenden Vorschriften zur Arbeitssicherheit, zur Betriebssicherheit, zum Umweltschutz sowie die einschlägigen örtlichen Vorschriften.

(FR) CONSIGNES DE SÉCURITÉ**Danger**

- Utilisez la tension correcte indiquée sur la plaque signalétique de la pompe afin d'éviter tout dommage.
- Ne procédez pas à des démontages, changements ou modifications non autorisés de la pompe qui pourraient entraîner des dysfonctionnements, voire des accidents.
- Mettez l'entraînement de la pompe hors tension avant d'installer ou de retirer des tuyaux, d'effectuer des travaux d'entretien, de nettoyage ou de réparation sur l'entraînement ou de connecter ou déconnecter des dispositifs de commande externes ou une interface de communication. Des doigts ou des vêtements lâches pourraient se prendre dans le mécanisme d'entraînement.

**Avertissement**

- Avant toute utilisation, assurez-vous qu'il n'y a pas de réaction chimique entre le liquide pompé et le matériau de la tête de pompe et des tubes.
- Les tuyaux doivent être contrôlés régulièrement pour éviter les ruptures. Une rupture de tuyau peut entraîner des projections de liquide hors de la pompe. Prenez les mesures appropriées pour protéger l'opérateur et l'équipement. L'opérateur est seul responsable des dommages causés par une rupture de tuyau, notamment en cas de fuite de liquides toxiques ou précieux.
- La pompe est équipée d'une fiche de mise à la terre qui doit toujours être bien reliée à la terre.
- Cet appareil n'est pas conçu ni prévu pour être utilisé en présence de patients, y compris, mais sans s'y limiter, dans le cadre d'applications médicales et dentaires.
- Respectez toutes les autres réglementations applicables en matière de sécurité du travail, de sécurité d'exploitation, de protection de l'environnement.

(ES) INSTRUCCIONES DE SEGURIDAD



Peligro

- Utilice la tensión correcta indicada en la placa de características de la bomba para evitar daños.
- No realice ningún desmontaje, cambio o modificación no autorizada en la bomba que pueda provocar un mal funcionamiento o incluso accidentes.
- Desconecte el accionamiento de la bomba antes de instalar o retirar las mangueras, realizar trabajos de mantenimiento, limpieza o reparación en el accionamiento o conectar o desconectar dispositivos de control externos o una interfaz de comunicación. Los dedos o la ropa suelta podrían quedar atrapados en el mecanismo de accionamiento.



Advertencia

- Antes de usarla, asegúrese de que no hay reacciones químicas entre el medio bombeado y el material de la cabeza de la bomba y las mangueras.
- Las mangueras deben ser revisadas regularmente para evitar roturas. La rotura de una manguera puede hacer que salga líquido de la bomba. Tome las medidas adecuadas para proteger al operador y al equipo. El operador es el único responsable de los daños causados por la rotura de una manguera, especialmente por la fuga de líquidos tóxicos o valiosos.
- La bomba está equipada con un enchufe con toma de tierra que debe estar siempre bien conectado a tierra.
- Este aparato no está diseñado ni pensado para su uso en relación con los pacientes, incluyendo pero sin limitarse a las aplicaciones médicas y dentales.
- Respetar todas las demás normas aplicables en materia de seguridad laboral, seguridad operativa y protección del medio ambiente.

(IT) ISTRUZIONI DI SICUREZZA**Pericolo**

- Usare la tensione corretta indicata sull'etichetta della targhetta della pompa per evitare qualsiasi danno.
- Non eseguire smontaggi, cambiamenti o modifiche non autorizzati alla pompa che potrebbero causare malfunzionamenti o addirittura potenziali incidenti.
- Spegnerne l'azionamento della pompa prima d'installare o rimuovere tubi, tentare qualsiasi manutenzione, pulizia o riparazione dell'azionamento, collegare o scollegare dispositivi di controllo esterni o un'interfaccia di comunicazione. Dita o indumenti larghi potrebbero rimanere impigliati nel meccanismo di azionamento.

**Attenzione**

- Assicurarsi che non si verifichino reazioni chimiche tra il fluido trattato e il materiale della testa della pompa e dei tubi prima dell'uso.
- I tubi devono essere controllati regolarmente per evitare rotture. La rottura del tubo può provocare spruzzi di fluido dalla pompa. Utilizzare misure appropriate per proteggere l'operatore e l'attrezzatura. L'operatore è l'unico responsabile dei danni derivanti dalla rottura dei tubi, in particolare della fuoriuscita di liquidi tossici o preziosi.
- La pompa è dotata di una spina con messa a terra che deve essere sempre ben collegata a terra.
- Questo dispositivo non è progettato né destinato all'uso in applicazioni collegate al paziente, incluso ma non limitato all'uso medico e dentistico.
- Osservare tutte le altre norme applicabili riguardanti la sicurezza sul lavoro, la sicurezza operativa, la protezione dell'ambiente e le norme locali pertinenti.

1 Description

BT-101L/BT301L/BT601L intelligent flow peristaltic pump provides not only intuitive and clear interface with color LCD touch screen, but also advanced features such as flow rate calibration and anti-drip function for accurate flow transfer. Easy Dispense Mode is available to dispense the recorded volume by pressing the DISPENSE key or using a footswitch. The system minimizes working noise due to the intelligent cooling fan control. With RS485 MODBUS interface, the pump is easy to communicate with external device, such as PC, HMI or PLC. This pump series includes:

- BT101L, flow rate: 0.00011-720 mL/min, speed: 0.1-150 rpm
- BT301L, flow rate: 0.006-1600 mL/min, speed: 0.1-350 rpm
- BT601L, flow rate: 0.006-2900 mL/min, speed: 0.1-600 rpm

2 Functions and Features

Advantage of peristaltic pump: Peristaltic pump can handle extremely viscous fluids, abrasive slurries and corrosive fluids. There is no seals in contact with the medium pumped and no valves to clog. The inner surfaces are smooth and easy to clean; fluid contacts only the tubing or tube material. Suction lift and priming can be up to 8m water column at sea level. It can handle the most shear sensitive of fluids like latex or firefighting foam with low shearing. It is capable of running dry and pumping fluids with high quantities of entrained air, such as black liquor soap. The high volumetric efficiency allows operation in metering or dosing applications where high accuracy is required. Tubing and tube materials are available for food and pharmaceutical use.

- Color LCD display, touch screen and keypad for operating.
- Reversible direction, start/stop control and adjustable speed.
- Flow rate calibration.
- Flow rate display and control; Cumulative dispense volume display.
- Anti-drip function ensures dispense accuracy.

- 0.2% high precision rotating speed control with 0.1 rpm speed resolution.
- Precise motor control technology improves dispense accuracy compared to the traditional dispense mode.
- Professional operating system, configure system with setup wizard.
- Intelligent temperature control to minimize working noise.
- Logic level signal can control start/stop, direction and easy dispense functions; external analog signal can adjust the rotating speed. Control signal is optically isolated.
- With RS485 MODBUS interface, easy to communicate with external device.
- Internal double-layer isolation structure; circuit board with conformal coating makes the pump dust-proof and moisture proof.
- Anti-electromagnetic interference feature, wide input voltage range for complex power environment.
- ABS plastic housing, streamlined shape.
- Drive multi-channels and various types of pump heads.
- Optional footswitch and remote infrared control.

3 Components and Connectors

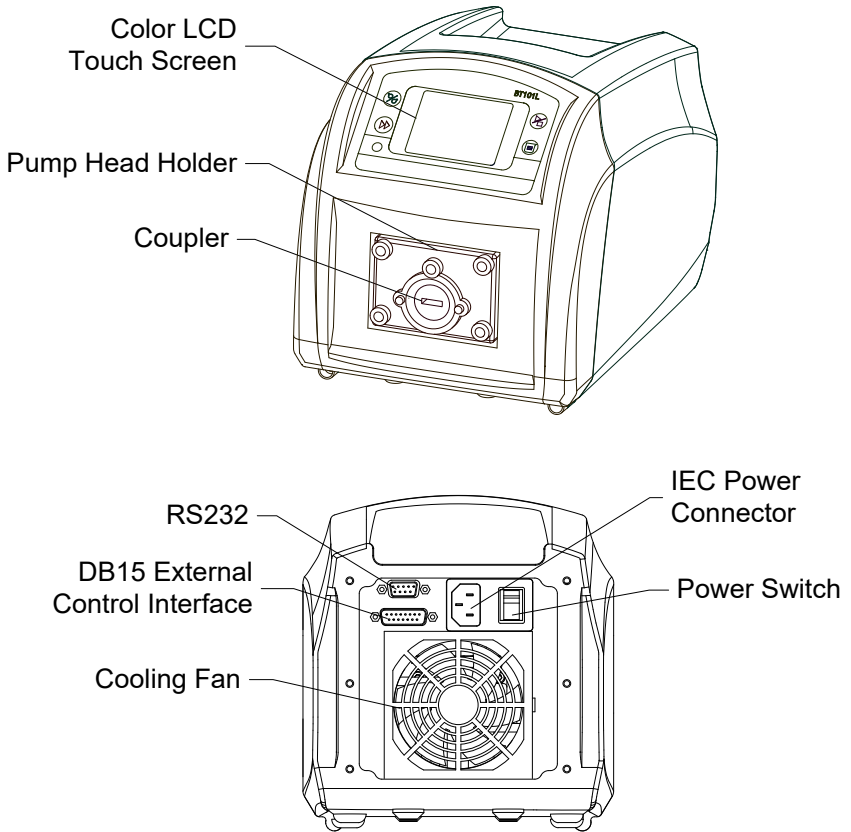

Figure 1. Components and Connectors

4 Display Panel and Operating Keypads

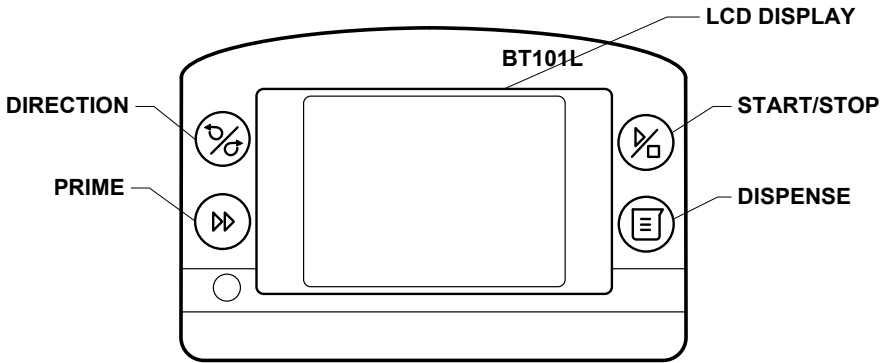

Figure 2. Display Panel

4.1 Keypad



START/STOP key. Press to start or stop drive.



DIRECTION Key. Press to change the drive rotating direction, clockwise or counterclockwise.



PRIME key. Press the key to run pump at maximum allowed speed in the direction shown on the display. Press again to return to the previous state.



DISPENSE key. When drive is not running, use this key to record dispense volume or start easy dispense.

4.2 LCD Touch Screen Display

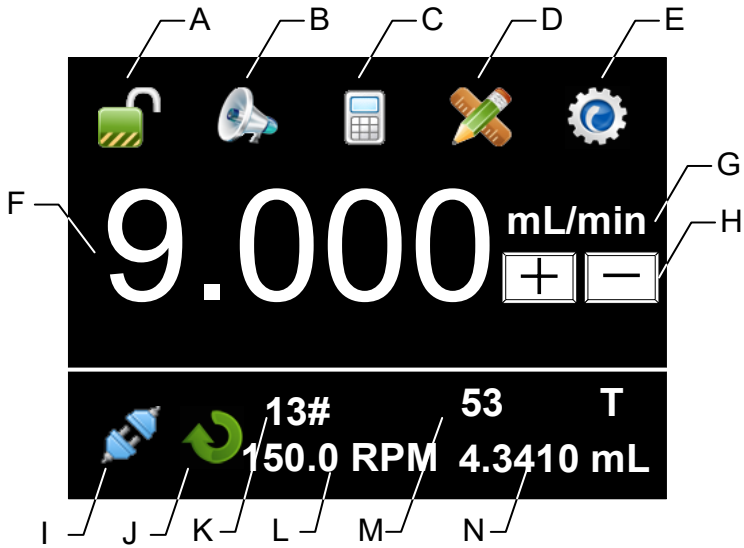

Figure 3. Main Display Screen

4.2.1 A - Keypad Lock

Shows the state of the keypad lock. Press the icon to lock/unlock the keypad. When the keypad is locked, the control mode and system parameter settings can not be changed.

Password can be set to unlock the keypad. It will prevent user from changing the system parameters accidentally.



Keypad locked



Keypad unlocked

Figure 4. Keypad Lock

4.2.2 B - Tone Button

Press the icon to turn on/off the key tone.



Tone on



Tone off

Figure 5. Key Tone

4.2.3



C - Control Mode

Press the icon to enter the Control Mode interface. There are four control modes available.

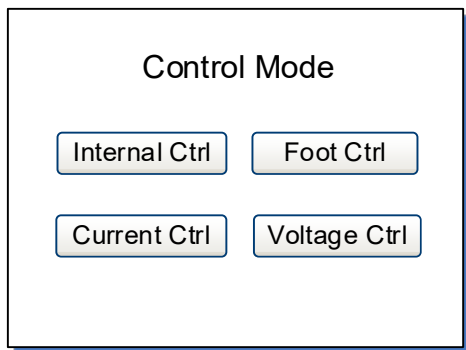

Figure 6. Control Mode

- **Internal Ctrl** - Internal Control Mode. Operate pump with keypad and touch screen.
- **Foot Ctrl** - Footswitch Control Mode. Footswitch controls start/stop. Use keypad and touch screen for the other operations.
- **Current Ctrl** - Current Control Mode. External 4-20mA analog current signal controls rotating speed; logic level signal controls start/stop. The keypad is disabled.
- **Voltage Ctrl** - Voltage Control Mode. External 0-5V or 0-10V analog voltage signal controls rotating speed; logic level signal controls start/stop and direction. The keypad is disabled.



Internal Control
Mode



Footswitch
Control Mode



Current Control
Mode



Voltage Control
Mode

Figure 7. Control Mode Icon



4.2.4 **D - Quick Settings**

Press the icon to enter Quick Settings interface to reset the cumulative volume and cycles.

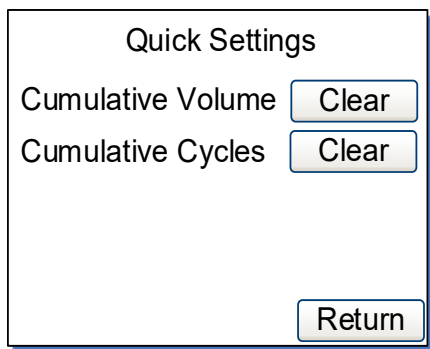

Figure 8. Quick Settings



4.2.5 **E - System Settings**

Press the icon to enter the System Settings menu, and then change the parameters shown on the screen.

4.2.6 **F - Flow Rate Setting**

It shows current flow rate. When the drive is not running, press it to input desired value in the pop-up window. Please pay attention to the range of the value and flow rate unit.

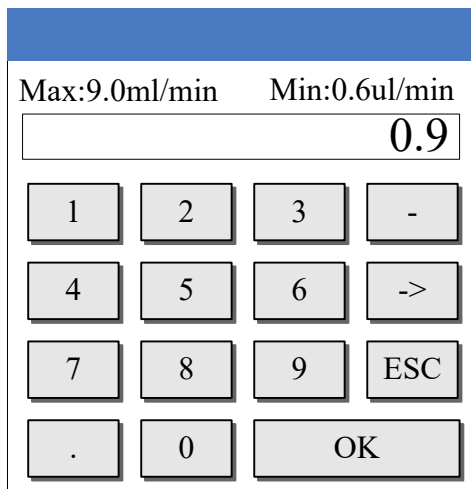



Figure 9. Flow Rate Setting

4.2.7 G - Flow Rate Unit

It shows current flow rate unit. When the drive is not running, press it to change the unit. The allowed units are $\mu\text{L}/\text{min}$, mL/min , L/min .

4.2.8 H - Fine Adjustment Button

When the drive is running, press the fine adjustment button to adjust the flow rate in real time. Press the  button or  button shortly to increase or decrease the flow rate. Press and hold the buttons to change the value quickly.

4.2.9 I - Communication State

It shows current RS485 communication state.



Communication
connected



Communication
disconnected

Figure 10. Communication State

4.2.10 J - Rotation Direction

It shows current rotation direction. When the drive is not running, it will show one of the following icon.



Clockwise Counterclockwise

Figure 11. Direction State

When the drive is running, it will change to an animated icon as shown below.



Figure 12. Running Animation

4.2.11 K - Tubing Size

It shows current configured tubing size or pump head model.

- 17# means the tubing size is 17#.
- ID0.13 means the internal diameter of the tubing is 0.13mm.

4.2.12 L - Rotating Speed

It shows current rotating speed. If the speed is higher than the maximum allowed speed, it will show **U_Overflow**; if the speed is lower than the minimum allowed speed, it will show **D_Overflow**.

4.2.13 M - Cumulative Cycles

It shows the cumulative cycles. The cycles can be reset on [Quick Settings](#) menu.

4.2.14 N - Cumulative Volume

It shows the cumulative volume that the pump has delivered. The cumulative volume can be reset on [Quick Settings](#) menu.

4.3 System Settings

When the pump is not running, press the icon  to enter System

Settings menu.



Figure 13. System Settings

4.3.1 Wizard

A wizard to set up the parameters. The system will select appropriate tubing and pump head for you.

4.3.2 Calibrate

Pump will accurately show current flow rate/volume after Flow Rate Calibration.

Note: The calibration is necessary to display flow rate precisely.

4.3.3 Setup

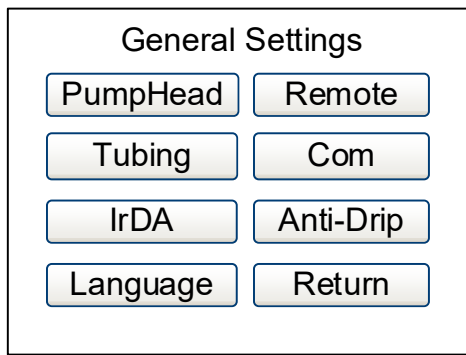

Figure 14. General Settings

- **PumpHead** - Choose the model of the suitable pump head.

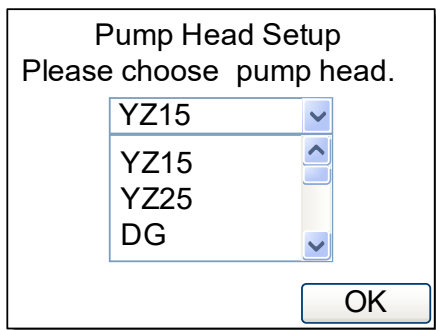

Figure 15. Pump Head Select

- **Tubing** - Choose the appropriate tubing size for selected pump head.

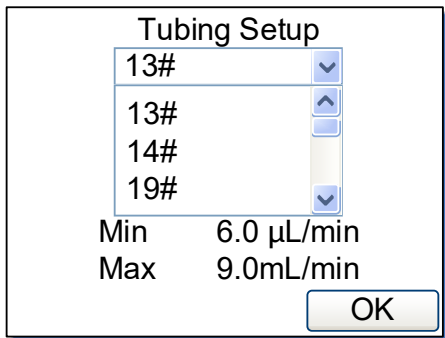

Figure 16. Tubing Select

- **IrDA** - Turn on/off the infrared control function.

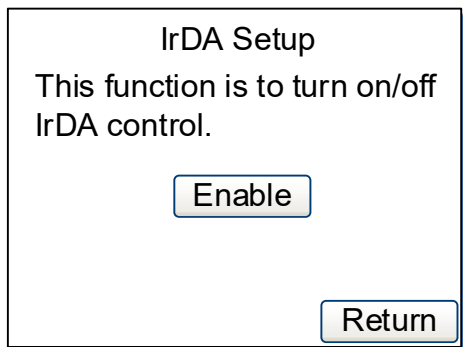

Figure 17. IrDA Setup

- **Language** - Choose display language, Chinese or English.



Figure 18. Language Select

- **Remote**

It is the setting for external signal control: Logic Level control mode or Pulse control mode. When it is set to Logic Level, pump state will change when external switch is closed or open. It is designed for a maintained switch. When it is set to Pulse, pump state will change when the switch is closed then open again. It is designed for a normally open momentary switch.

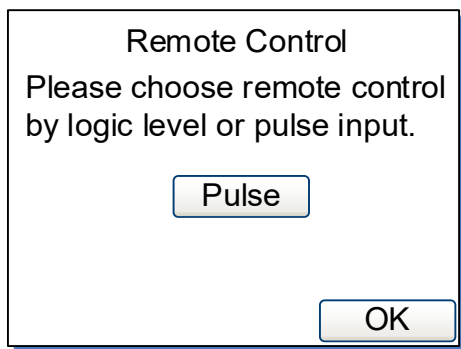
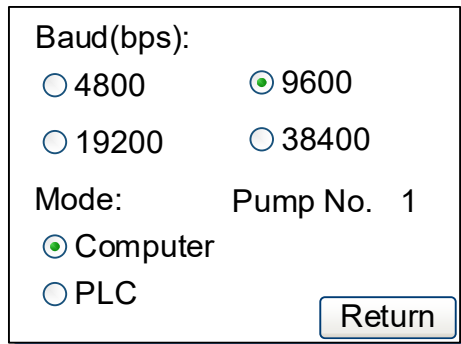

Figure 19. Remote Control Mode

- **Com**

It is the setting for RS485 MODBUS communication including baud rate, transmission mode and pump address. To change the address, click the address number on the screen, then input the value in the pop-up window. Restart the pump to apply the settings.



A dialog box titled "Communication Settings" with a blue border. It contains the following options:

- Baud(bps):
 - 4800
 - 9600
 - 19200
 - 38400
- Mode:
 - Computer
 - PLC
- Pump No. 1
-

Figure 20. Communication Settings

- **Anti-Drip**

The pump provides deceleration time setting to reduce fluid splash at the end of a dispense. It is the time for the drive to stop from the running speed to 0. In addition, to minimize the drip after a dispense, the drive can reverse direction to draw the fluid back at the end of the tubing. To access this feature, set the reverse angle/rotating speed in the pop-up window. When the angle is set to 0, this feature is disabled.

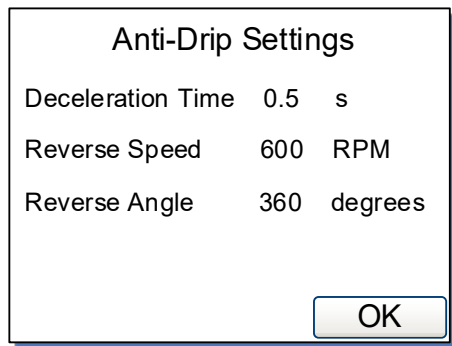

A dialog box titled "Anti-Drip Settings" with a blue border. It contains the following settings:

Deceleration Time	0.5	s
Reverse Speed	600	RPM
Reverse Angle	360	degrees

Figure 21. Anti-Drip Setting

4.3.4 Info

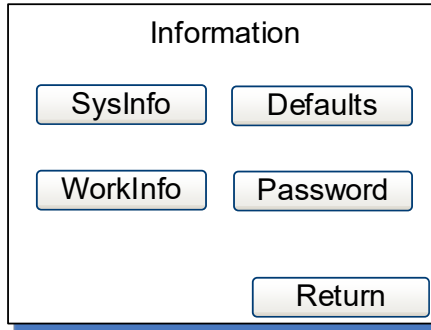

Figure 22. Information

It is about pump information.

- **Sysinfo**

It shows software version, memory size, internal temperature, etc.

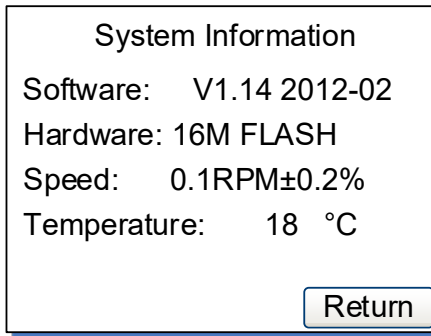

Figure 23. System Information

- **Workinfo**

It shows total power on time, running time and power cycles.

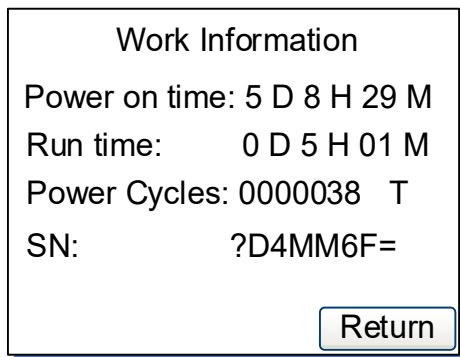



Figure 24. Work Information

- **Defaults**

It is to reset the pump to factory settings. Restart pump to apply the settings. The system can also restore to factory settings by holding

the  and  at the same time when pump powers on; then release the keys after the beep.

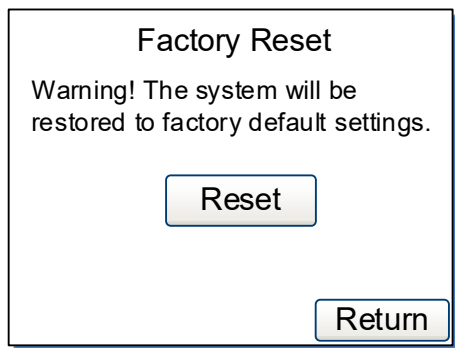

Figure 25. Factory Reset

- **Password**

Set a password to unlock the keypad. It will prevent user from changing parameters accidentally. The default password is empty.

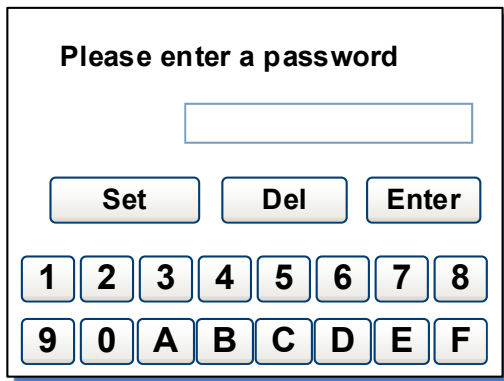

Figure 26. Password

4.3.5 About

It shows the functions and features about the pump.

4.3.6 Return

To return the main display screen.

5 External Control Interface

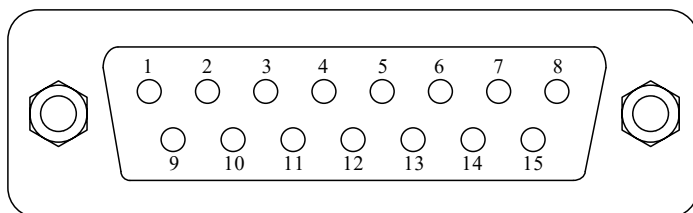

DB15	Mark	Note
1	ADC_W	Positive of external analog input
2	B	Communication interface, B pole of RS485
3	A	Communication interface, A pole of RS485
4	VCC_W	External DC power input
5	DAC	Analog voltage signal output
6	CW_W	External input signal to control direction

7	PWM	Pulse signal output
8	COM	Ground of external power
9	AGND	Negative of analog signal input
10	+12V	Positive of internal +12V power source
11	GND	Ground of Internal power source
12	CW	Direction signal output
13	RS_W	External start/stop signal input
14	PWM_W	Pulse signal input
15	RS	Start/stop signal output

6 Operation Instructions

6.1 Before Operation

- 1) Please check the packing slip to make sure nothing is wrong or damaged in the package. If there is problem, please contact the manufacturer or distributor.
- 2) Please carefully read through the instructions.
- 3) There should be more than 200 mm space for the back of the pump when it is running.

6.2 Power Connection

The voltage of the power supply should be marked on the sticker of the pump. Please make sure to use the right power source for the pump. Please plug the power cord into the IEC Power Connector on the rear of the pump and plug the opposite end of the power cord into an electrical outlet. Flip the power switch located on the rear of the pump.

6.3 First Run Wizard

When use the pump at the first time or after factory reset, the system will show welcome screen. The next step is to choose the model number of the pump head installed. The system will run Pump Head Setup -> Tubing Setup -> Anti-Drip setup -> Calibration in sequence. Pump will save the information and you only need to run the wizard once.

Pump Head Setup
Please choose pump head.

YZ15
YZ15
YZ25
DG

OK

Tubing Setup

13#
13#
14#
19#

Min 6.0 µL/min
Max 9.0 mL/min

OK

Anti-Drip Settings

Deceleration Time 0.5 s
Reverse Speed 600 RPM
Reverse Angle 360 degrees

OK

13# Tubing Calibration

6.000 mL/min
3.000 mL

Suggested testing vol >3.000mL to reach 0.5% precision.

Next Return

Figure 27. First Run Wizard

6.4 Flow Rate Calibration

The calibration must be done when

- First time to use the pump
- Pump head is changed
- Tubing is replaced
- Transfer fluid in one channel with dual pump heads
- Tubing is reinstalled
- After continuous work for a long time

How to calibrate

- 1) Install pump head and tubing.
- 2) In the General Settings window, set the model number of the installed pump head.
- 3) In the Main Display Screen window, press PRIME  key to prime the pump.



- 4) When the drive is not running, press System Settings icon, then select Calibrate.



Figure 28. System Settings

- 5) In calibration wizard window, system shows the calibration of current selected tubing, flow rate and fluid volume.

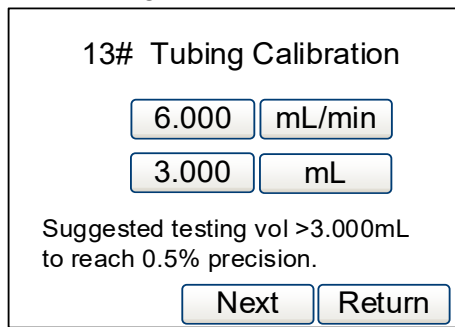

Figure 29. Flow Rate Calibration

The flow rate 6.000 mL/min is the desired flow rate and 3.000 mL is the fluid volume need to test. The values or the units can change directly when press the button. Press Next button to enter the calibration window, or press the Return button to exit the wizard to the System Settings window.

Note: The testing volume should not be less than the suggested value.

6) Test window shown below.

Press start/stop key to test, then input the data.		
Test1	0.000	mL
Test2	0.000	mL
Test3	0.000	mL
Prev	Next	Return

Figure 30. Calibration

Press START/STOP key to start transferring fluid. Wait for the pump to finish testing, and then measure the volume of the transferred fluid. Repeat the above steps couple more times, and enter the results of the Test1, Test 2 and test 3 in the calibration window. Please pay attention to the unit to make sure it is correct. Press Next to enter Analyze and Calculate window.

If you want to modify the test flow rate and liquid volume, press Prev button to re-enter the values.

Note: If an accident occurs during the process of the test, please press START/STOP key to stop the test.

Input one set or multiple sets of testing data to the pump, the system will calculate the average value automatically.

7) The correction testing result will be calculated and the old value is displayed on the screen for reference only. The new value and old value would be different. However, if the ratio of new to old value is less than 0.5 or higher than 2, please check the following.

- Volume measurement
- The volume unit setting
- The model of the pump head setting
- The tubing size setting
- The liquid viscosity if it is too high
- If dual pump heads are used for one channel

If no problem found, press OK button to save the new value.

Otherwise, press **Prev** to test again. Or, press **Return** to exit without saving the new value and return to the System Settings window.

Analyze and Calculate	
Average Vol	3.068 mL
Cal scale	208.6957
Re scale	213.3330
Old scale	213.3330

Figure 31. Analyze and Calculate

If there is no data input to the system, it will show the window as below. Please press **Prev** to test again or just press **Return**.

Analyze and Calculate	
No data. Please go back to re-enter the data or return to the main menu.	

Figure 32. No Input Data

6.5 Run Wizard

The system will help you to choose the appropriate pump head and tubing size automatically by running this wizard.

- 1) When the drive is not running, press the icon , then select Wizard. Pump will display Welcome screen. Press Next to enter parameter setup interface.

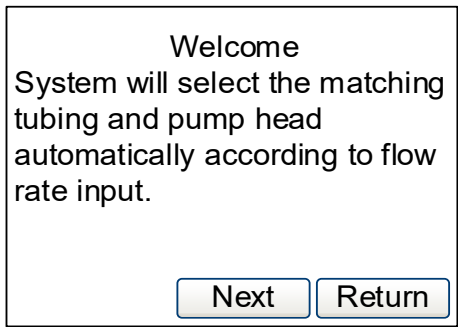

Figure 33. Welcome Screen

- 2) Input the desired values as shown below.

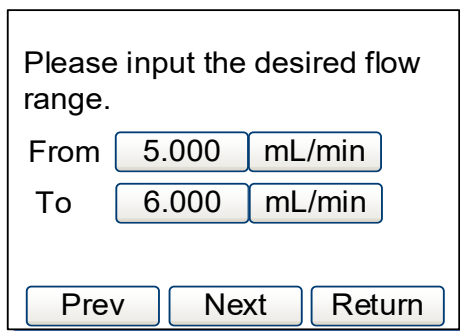

Figure 34. Flow Rate Input

- 3) Press Next button, system will list appropriate pump heads automatically. Select the desired pump head and tubing. If there is no pump head listed, go back to re-enter the data.

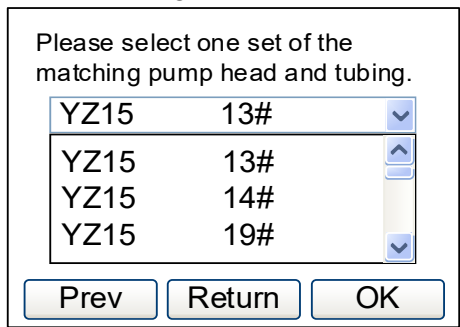

Figure 35. Appropriate Pump Heads List

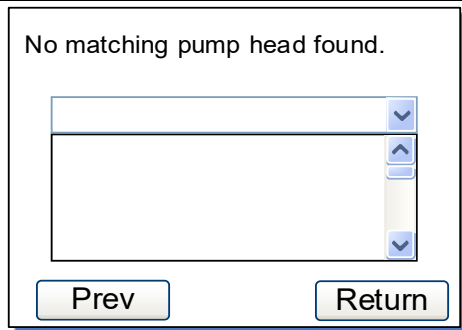

Figure 36. No Appropriate Pump Head

6.6 Easy Dispense Mode

The pump will dispense fluid by recording the volume for each dose.

To record the volume for each dose

- 1) Turn on the power switch. The LCD display will be on.
- 2) On the Main Display Screen, Press PRIME key to fill tubing with fluid.
- 3) When the drive is not running, press and hold DISPENSE key until the display flashes "Recording". Then the pump is on Easy Dispense Recording Mode.

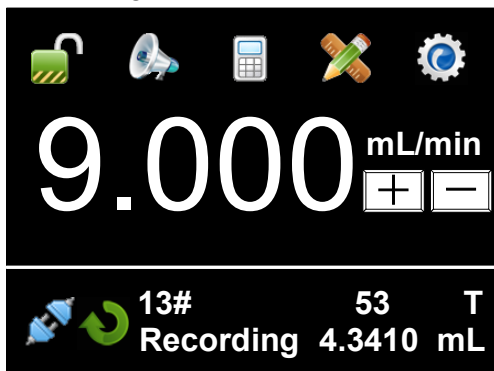

Figure 37. Easy Dispense Recording Mode

- 4) Press START/STOP key to start fluid transfer. When it has delivered the desired volume, press START/STOP key again to stop the pump. You can start/stop the drive multiple times to

adjust the volume, or press the PRIME key to fine adjust the volume, until the cumulative volume reaches the desired volume.

- 5) Press the DISPENSE key to exit the Easy Dispense Recording mode. Pump will record the cumulative volume for Easy Dispense Mode. The “Recording” will change to the rpm setting.

To dispense fluid, on *Internal Control Mode*, press DISPENSE key to dispense the recorded fluid volume once. In addition, the cumulative dispense cycles will increase 1. A footswitch can be used to start dispensing.

Note: If an accident occurs, press START/STOP key to stop dispensing at any time.

6.7 External Control Mode

On this mode, logic level signal controls direction and start/stop. External analog signal controls rotating speed. The keypad is disabled. The analog signal could be 0-5V, 0-10V or 4-20mA. By default, the signal is 0-5V. For 0-10V or 4-20mA, the jump setting on the analog signal control board has to be changed.

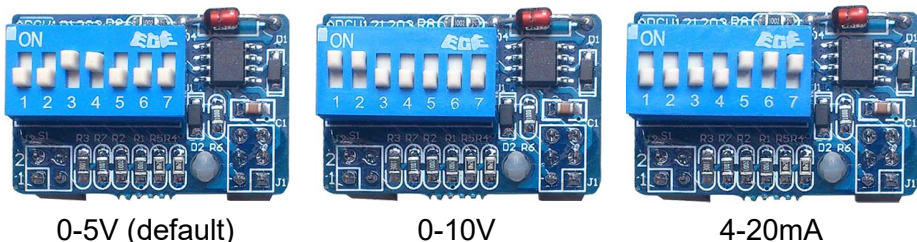

Figure 38. Analog Signal Control Board Setting

To control pump by external signal

- 1) Switch the power off. Wire the DB15 connector as shown on [Figure 39](#) or [Figure 40](#), and connect it to the DB15 port on the rear of the pump.

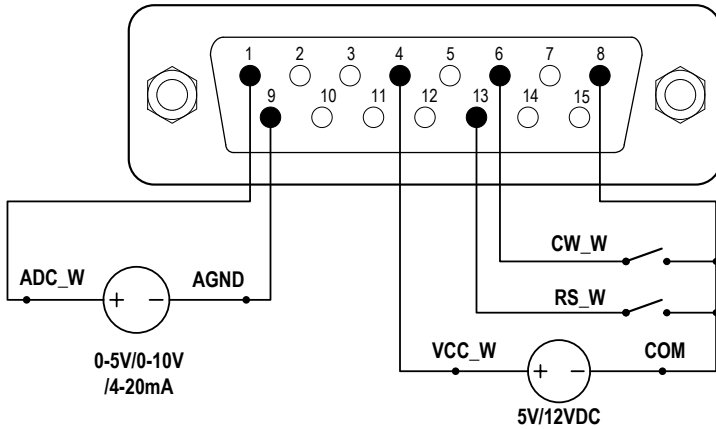

Figure 39. DB15 Wiring with External 5V or 12VDC Power Source

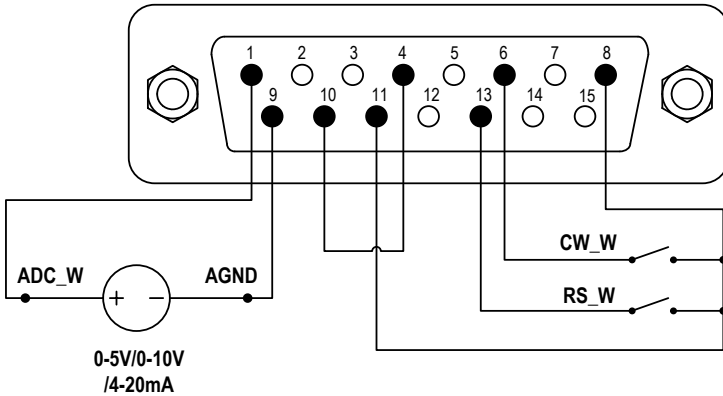





Figure 40. DB15 Wiring with Internal 12VDC Power Source

- 2) Turn on the power switch. Pump will display the main screen.
- 3) Press  to set Control Mode to voltage  or current .
- 4) Turn on the external analog signal power source.
- 5) When set the Remote Control Mode to Logic Level, close the external RS_W switch, the pump will run and the speed will change according to the intensity of the analog input signal. Open RS_W switch to stop pump.
When CW_W switch is open, pump will run in clockwise direction; when CW_W switch is closed, pump will run in counterclockwise

direction.

- 6) When set the Remote Control Mode to Pulse, close then open the external RS_W switch, the pump will run and the speed will change according to the intensity of the analog input signal. Close and open RS_W switch again to stop pump.

When close then open the external CW_W switch, pump will run in clockwise direction; when close then open CW_W switch again, pump will run in counterclockwise direction.



Voltage Control Mode



Current Control Mode

Figure 41. Control Mode Setting

Note: The external DC power source can be 5V, 12V. If it is 24V, 1.5K resistor is needed to protect internal circuit.

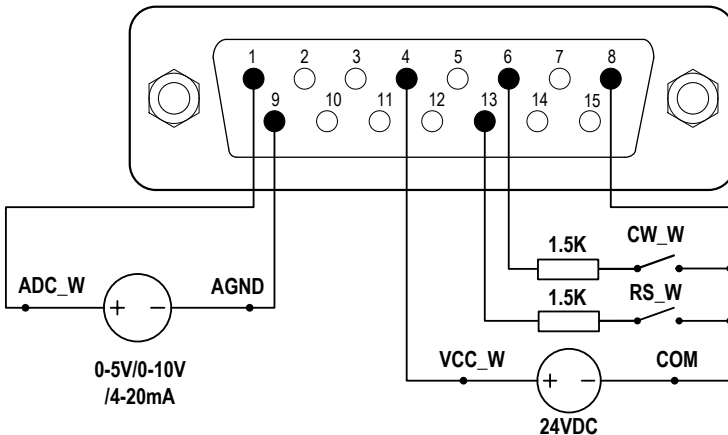

Figure 42. DB15 Wiring with External 24VDC Power Source

6.8 Communication Mode

The RS485 interface supports standard MODBUS protocol. Pump can communicate with external device via the communication port. Please refer to the [Communication Instruction manual](#) for the parameters and supported commands.

To work with communication mode

- 1) Turn the power off. Wire the DB15 connector as shown on [Figure 43](#), and connect it to the DB15 port on the rear of the pump. External DC power source is recommend to avoid electrical interference.

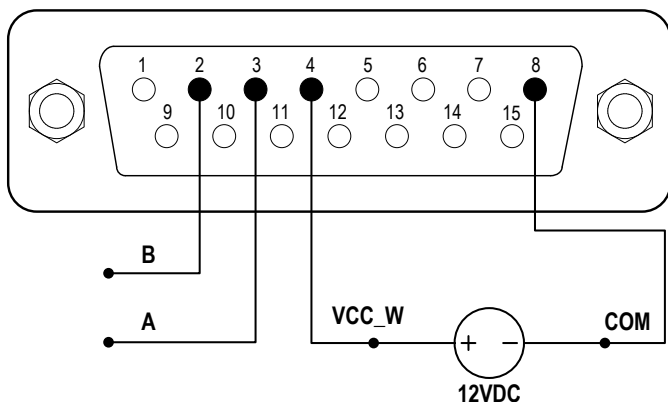



Figure 43. RS485 MODBUS Wiring

- 2) Turn the power on. Pump will display the main screen.
- 3) On Internal Control Mode, when the main screen shows , the communication is connected. When the screen shows , the communication is disconnected.
- 4) Control pump with communication interface.

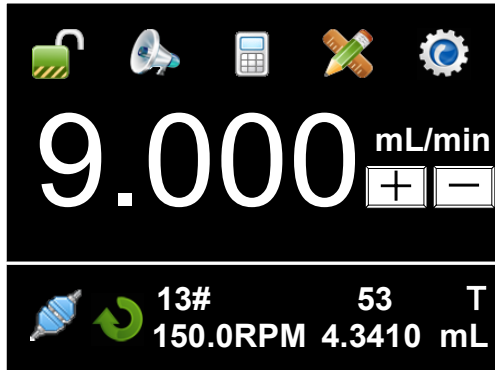

Figure 44. Communication Connected

6.9 Footswitch

To use a footswitch to control start and stop

- 1) Power pump off. Wire the DB15 connector as shown on [Figure 45](#) or [Figure 46](#), and connect it to the DB15 port on the rear of the pump.

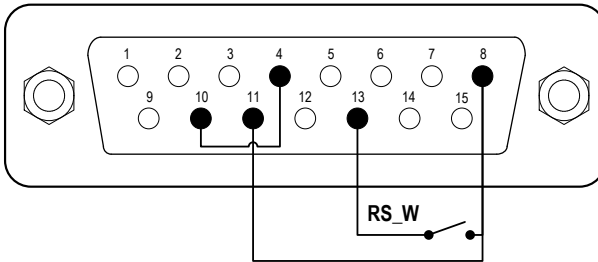

Figure 45. Control Start/Stop with Internal 12V Power Source

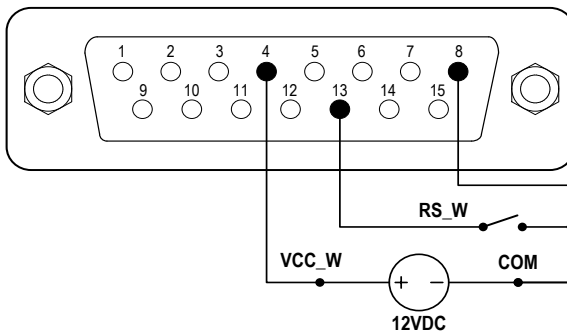

Figure 46. Control Start/Stop with External 12V Power Source

- 2) Turn the power on. Pump will display the main screen.
- 3) On Internal Control Mode, when the switch RS_W is closed then open, pump will start to dispense.
- 4) On Footswitch Control Mode, if Remote Control Mode is set to Logic Level, when the switch RS_W is closed, pump will start; when the switch is open, pump will stop.

If Remote Control Mode is set to Pulse, when the switch RS_W is closed then open, pump will start; when the switch is closed then open again, pump will stop.

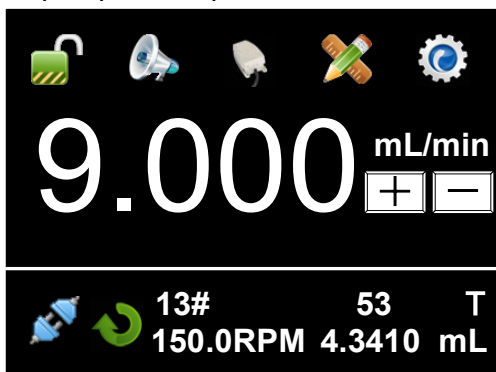

Figure 47. Footswitch Control

7 Maintenance

7.1 Warranty

The product comes with one-year labor and parts warranty. The limited warranty does not cover any damage that is caused by improper usage and handling.

7.2 Regular Maintenance

- 1) Always check the tubing and connections to make sure there is no leakage.
- 2) Do not cover the fan on the rear of the pump.
- 3) Do not use water to wash the pump. Keep pump head dry.
- 4) Do not use chemical solvents to clean pump and pump head.

7.3 Malfunction Solutions

No.	Malfunction	Description	Solution
1	Hardware	No display	<ol style="list-style-type: none"> 1. Check the power cord 2. Check the fuse. If it was blown, replace it with a 1A slow-blow fuse 3. Check the internal power cord connection inside the pump. 4. Check the wire connection between LCD and main control board.
2	Hardware	Motor does not work	<ol style="list-style-type: none"> 1. Check the indicator of the driver board. 2. Check the wire connection between motor and driver board. 3. Check the wire connection between the driver and the main board. 4. Check the power voltage for the pump.
3	Hardware	Motor is trembling	<ol style="list-style-type: none"> 1. Check the wire connection between the motor and the driver board. 2. The motor is overloaded. Check the mechanical connection.
4	Hardware	Motor only runs in one direction	Check the connection between the drive board and the main control board.
5	Hardware	Keypad does not work	<ol style="list-style-type: none"> 1. Check the wire connection between keypad and the main board. 2. Check if the key is broken.
6	Hardware	External	<ol style="list-style-type: none"> 1. Check the wiring of the

		control does not work	connector. 2. Check if the external control power voltage is provided. 3. Check the connections of the external control board.
7	Hardware	RS485 com does not work	1. Check the wiring of the connector. 2. Check if the external control power voltage is provided. 3. Check the connections of the communication board.
8	Hardware	Noisy when running	Check the screws and lever on pump head to make sure they are secure.
9	Software	External control does not work	Check if pump is on External Control Mode.
10	Software	RS485 does not work right	1. Check if the display shows the communication is ready. 2. Reset the address of the pump. 3. Check whether on the bus there are two pumps using the same address



If the problem can not be solved, please contact the manufacturer or distributor.

8 Dimensions

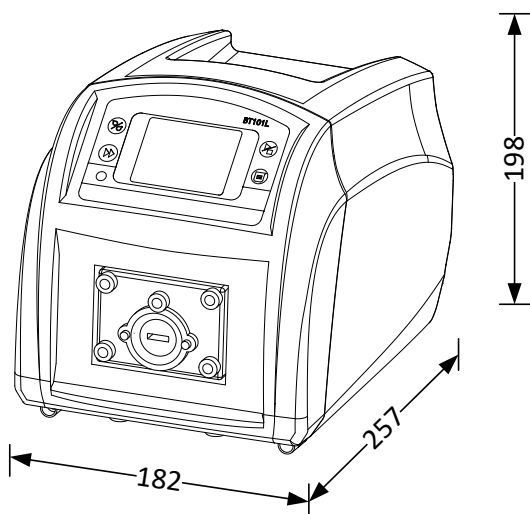
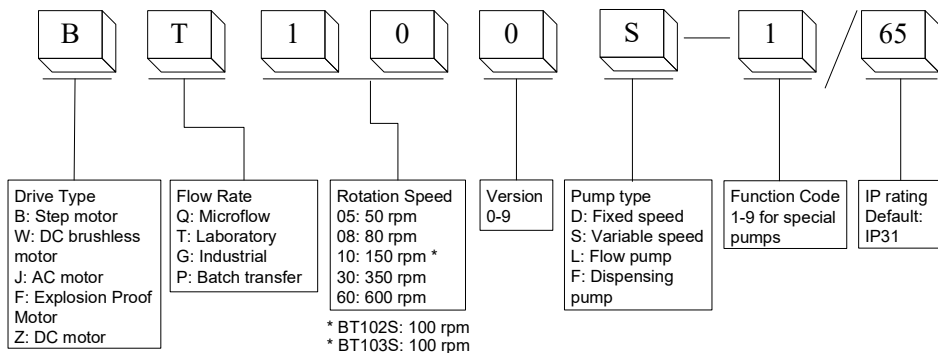

Figure 48. Dimensions (mm)

9 Naming Rule



10 Specifications

Speed resolution	0.1 rpm
Speed accuracy	0.2%
Power supply	AC 90-240, 50/60Hz
Power consumption	BT101L: < 30W; BT301L:< 40W; BT601L: < 50W
External logic level control signal	5V, 12V (standard), 24V (optional)
External analog control signal	0-5V (standard); 0-10V, 4-20mA (optional)
Communication interface	RS485 MODBUS
Operating condition	Temperature 0~40°C Relative humidity <80%
IP grade	IP31
Display	TFT Touch Screen LCD, 65536 Colors
Dimensions (LxWxH)	257 x 198 x 182mm (10.12 x 7.80 x 7.17 inch)
Weight	BT101L: 4.8 kg (10.6 lbs); BT301L: 5.3 kg (11.7 lbs); BT601L: 5.5 kg (12.1 lbs)

BT101L Suitable Pump Heads and Tubing, Flow Parameters

Drive type	Pump head	No. of Channels	Tubing size (mm)	Flow rate per channel (mL/min)
BT101L (ABS)	DG6-1 (6rollers)	1	Wall:0.8~1, ID:≤2.4	0.00016~26
	DG10-1(10rollers)	1	Wall:0.8~1, ID:≤2.4	0.00011~20
	DG6-2 (6rollers)	2	Wall:0.8~1, ID:≤2.4	0.00016~26

BT101L/BT301L/BT601L Intelligent Flow Peristaltic Pump

	DG10-2 (10rollers)	2	Wall:0.8~1, ID:≤2.4	0.00011~20
	DG6-4 (6rollers)	4	Wall:0.8~1, ID:≤2.4	0.00016~26
	DG10-4 (10rollers)	4	Wall:0.8~1, ID:≤2.4	0.00011~20
	DT10-18	1	13# 14#, Wall:0.8~1, ID:≤3.17	0.0002~82
	DT10-28	2	13# 14#, Wall:0.8~1, ID:≤3.17	0.0002~82
	YZ15	1	13# 14# 16# 19# 25# 17#	0.0006~420
	YZ25	1	15# 24#	0.16~420
	YT15	1	13# 14# 16# 19# 25# 17# 18#	0.006~570
	YT25	1	15# 24# 35# 36#	0.16~720

BT301L Suitable Pump Heads and Tubing, Flow Parameters

Drive type	Pump head	No. of Channels	Tubing size	Flow rate per channel (mL/min)
BT301L (ABS)	YZ15	1	13# 14# 16# 19# 25# 17#	0.006~990
	YZ25	1	15# 24#	0.16~990
	YT15	1	13# 14# 16# 19# 25# 17# 18#	0.006~1300
	YT25	1	15# 24# 35# 36#	0.16~1600

BT601L Suitable Pump Heads and Tubing, Flow Parameters

Drive type	Pump head	No. of Channels	Tubing size	Flow rate per channel (mL/min)
BT601L (ABS)	YZ15	1	13# 14# 16# 19# 25# 17# 18#	0.006~1700
	YZ25	1	15# 24#	0.16~1700
	YT15	1	13# 14# 16# 19# 25# 17# 18#	0.006~2300
	YT25	1	15# 24# 35# 36#	0.16~2900

Golander LLC

4405 International Blvd
Ste B117, Norcross, GA 30093
USA

Tel: +1 678-587-8806
info@golanderpump.com
www.golanderpump.com

Golander GmbH

Dechant-Heimbach-Str. 29
53177 Bonn
Germany

Tel: +49 228 50446952
info@golander.de
www.golander.de