

STINGER

GOLF PRODUCTS

SG-5E

OPERATING INSTRUCTIONS



Visit our website for detailed video instructions



WWW.STINGERGOLF.COM.AU



03 5924 6056

CONTENTS

CHARGING THE BATTERY.....	Page 3
IMPORTANT: BATTERY INFORMATION.....	Page 4
SETTING UP THE BUGGY.....	Page 5
FITTING & REMOVING ANTI-TIP WHEEL.....	Page 10
FITTING THE ACCESSORIES.....	Page 11
CONNECTING THE BATTERY.....	Page 12
OPERATING THE BUGGY.....	Page 15
BATTERY LEVEL INDICATOR.....	Page 16
USB CHARGING PORT.....	Page 17
PACKING DOWN THE BUGGY.....	Page 18
DEPLOYING THE BUGGY STAND.....	Page 23

Visit our website for detailed video instructions



WWW.STINGERGOLF.COM.AU



03 5924 6056

CHARGING THE BATTERY



FIGURE 1

STEP 1:

- Before connecting the charger to the 240 volt wall power outlet, connect the red & black connectors to the battery as indicated by the arrow in figure 1.



FIGURE 2

STEP 2:

- Now connect the power lead to the power outlet and switch on at wall.

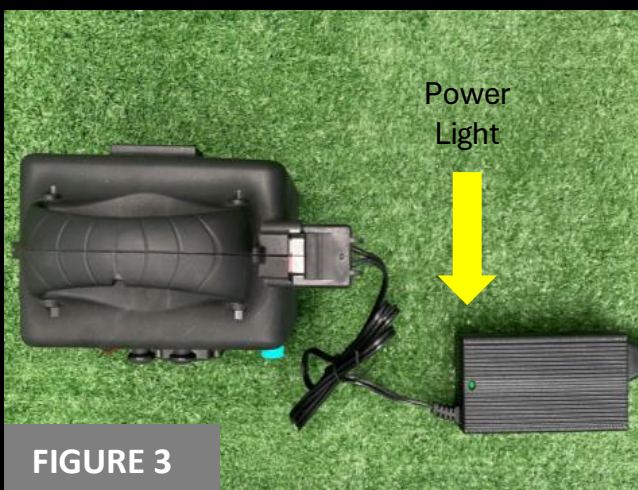

FIGURE 3

STEP 3:

- The power light on the charger will illuminate '**RED**' when charging and '**GREEN**' when fully charged.

Please refer to Battery Information on the following page.

IMPORTANT:

BATTERY INFORMATION

LITHIUM BATTERY INFORMATION

- Lithium Batteries come with an electronic management system built in, (BMS) which protects the lithium battery from any sort of abuse or misuse.
- In the unlikely event that your BMS shuts down the power, disconnect the battery from the buggy, wait 30 seconds, and re-connect. This should re-set the BMS and power will return.
- **WARNING** – DO NOT ATTEMPT to open the battery outer casing.
- Check with your airline before attempting to transport by air as lithium batteries are listed as dangerous goods Class 9 UN3480 or UN3481
- Avoid letting the battery get too wet or immersed in water.
- Your battery should not be left uncharged for periods more than 2 weeks.

CHARGING PROCEDURE

- Recharge your battery after each use even if you have only played a part round of golf. Do not allow your battery to run flat.
- **USE ONLY** the authorized Lithium Battery Charger supplied with your lithium battery.
- **DO NOT** use a charger designed for lead acid batteries.

TO CHARGE: PLEASE FOLLOW THESE INSTRUCTIONS CAREFULLY

- Unplug and disconnect the battery from the buggy.
- Connect the battery to the charger and THEN to a power point. Next, turn the mains power on and the charging indicator RED light will be on.
- The lithium battery will be fully charged when the RED light turns to GREEN – It is ok to leave the battery on charge between rounds of golf.
- To disconnect battery from the charger once the battery is fully charged. Turn the mains power off, then disconnect the battery from the charger. Always follow this sequence.
- Charge your lithium battery on a dry, non-carpeted area at temperatures between 10°C to 30°C. Charging below 0°C can cause long term damage.

CONNECTING BATTERY TO BUGGY

- Always ensure that the battery leads are connected to the buggy correctly.

SETTING UP THE BUGGY



FIGURE 1

STEP 1:

- Unlock the top handle of the buggy as per figure 1.

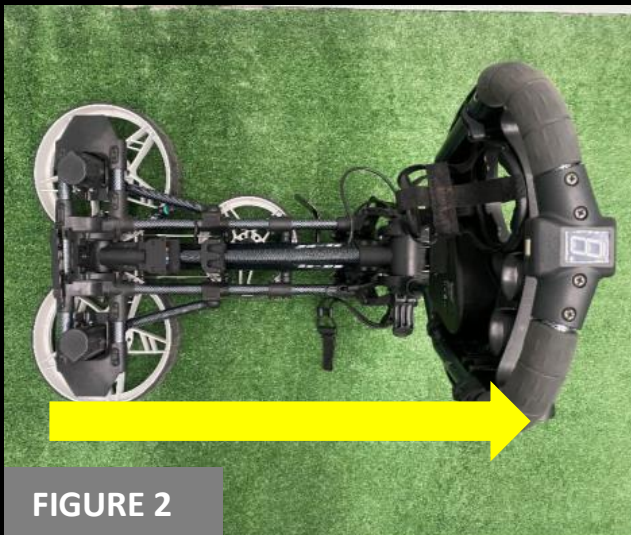

FIGURE 2

STEP 2:

- Raise the handle until it is 90 degrees to the frame of the buggy as per figure 2.



FIGURE 3

STEP 3:

- Lock the top handle of the buggy as per figure 3.



FIGURE 4

STEP 4:

- You are now able to open the buggy by pushing back on the top bag support and pushing down on the front of the buggy as per figure 4 until the buggy is completely open as per figure 5.



FIGURE 5

STEP 5:

- You are now ready to unfold the front wheel.



FIGURE 6

STEP 6:

- Tilt the buggy backwards as per figure 6.



FIGURE 7

STEP 7:

- Push down on the lever and then front wheel at the same time, until the front wheel releases from its locked position as per figure 8.



FIGURE 8

STEP 8:

- Continue to push down on the lever until the front wheel fully locks into the open position as per figure 9.



FIGURE 9

STEP 9:

- The front wheel is now fully locked and the buggy is ready for the battery to be connected for play.



FIGURE 10

STEP 10:

- Please refer to connecting the battery section.

FITTING AND REMOVING THE ANTI-TIP WHEEL

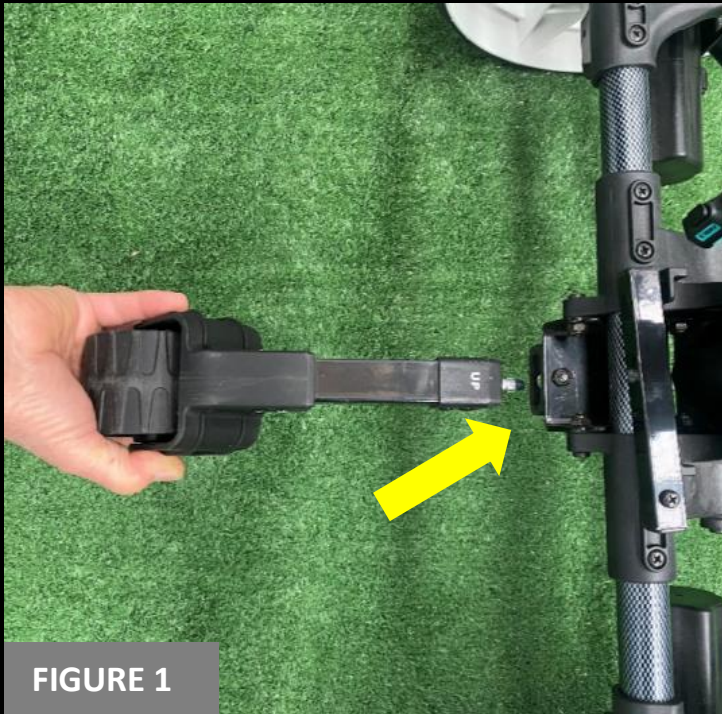

FIGURE 1

STEP 1:

- Slide the anti-tip wheel into the mounting point until it clicks into place as per figure 2.



FIGURE 2

STEP 2:

- To remove the anti-tip wheel from the buggy, press the **red** button under the buggy & pull out from the mounting.

FITTING THE ACCESSORIES



Umbrella Holder:

- Screw the umbrella holder into umbrella mount as per figure 1.



Sand Bottle:

- To attach sand bottle, clip bottle onto fitting provided on the buggy as per figure 2.

CONNECTING THE BATTERY



STEP 1:

- Ensure the battery is turned off before connecting to the buggy as per figure 1.

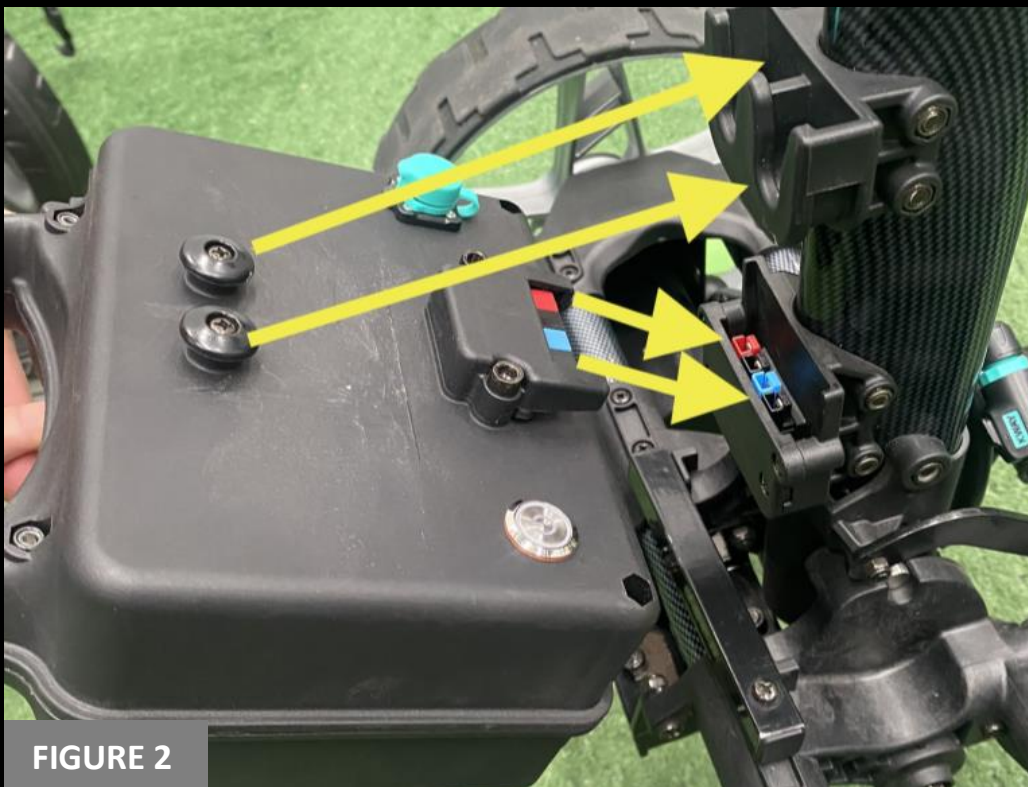

STEP 2:

- Ensure the two round lugs on the battery and the two electrical connectors are all lined up, indicated by the yellow arrows as per figure 2.



FIGURE 3

STEP 3:

- Push down on the battery until the two battery round lugs lock into place as per figure 3.



FIGURE 4



FIGURE 5

STEP 4:

- Connect the electrical lead from the buggy to the battery as indicated by the yellow arrow in both figures 4 & 5.



FIGURE 6

STEP 5:

- Turn on the battery by pushing the silver button as per figure 6 and a indicator light will turn red. You are now ready to operate the buggy.
- **Please Note:** If the buggy has not been used for more than one hour, the power supply will automatically turn off. Please repeat Step 5 to turn the battery back on.

OPERATING THE BUGGY



FIGURE 1

STEP 1:

- When the battery is switched on, the top handle display will flash '0' in green as per figure 1.



FIGURE 2

STEP 2:

- To start the buggy, push in the speed dial in the direction of the arrow as per figure 2. Then turn the speed dial towards the positive symbol to increase the speed & towards the negative symbol to decrease the speed which will be indicated by speeds '1-9' on the display screen as per figure 3.



FIGURE 3

BATTERY LEVEL INDICATOR

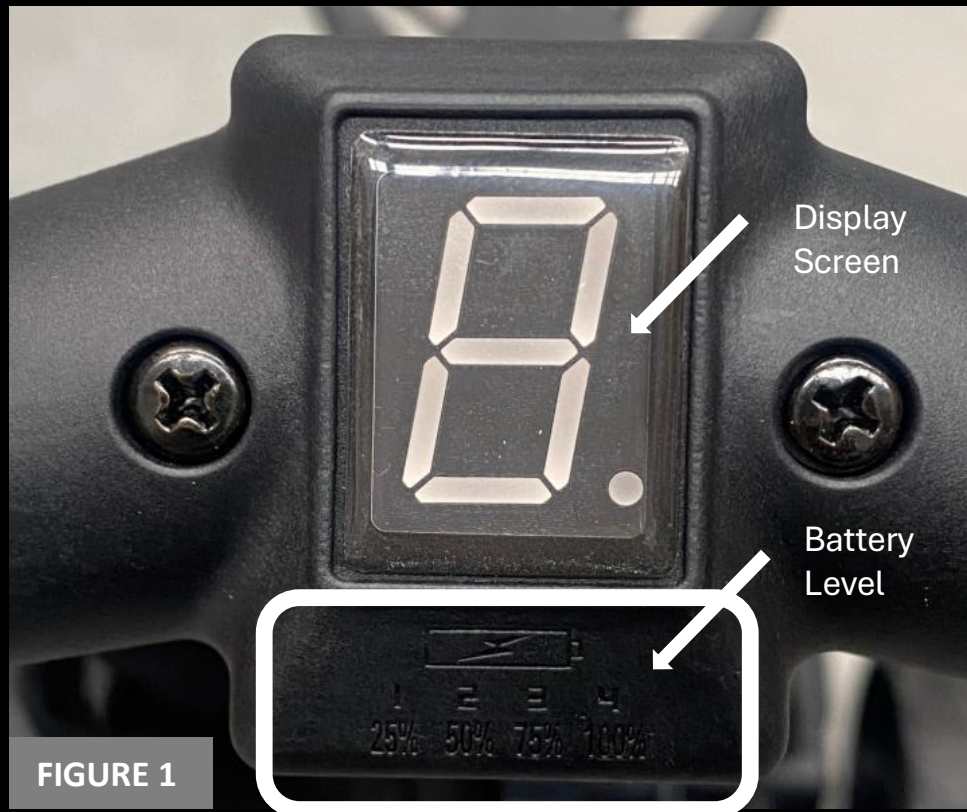

- Press and hold the speed dial for 3 seconds, and the digits 1, 2, 3 or 4 will illuminate on the display screen.
- 1 = 25% charge
- 2 = 50% charge
- 3 = 75% charge
- 4 = 100% charge

Please Note: When battery power is equal to or less than 5%, please charge battery to ensure 18 holes of golf.

USB CHARGING PORT



FIGURE 1

STEP 1:

- The USB charging port is located under the display screen as indicated by the arrow in figure 1.



FIGURE 2

STEP 2:

- You can now connect the USB charging device to your phone or GPS unit as per figure 2.

PACKING DOWN THE BUGGY

IMPORTANT NOTICE: Battery MUST be removed before attempting to pack down the buggy



STEP 1:

- To turn off the battery, push in & hold the speed dial as per fig 1. After 3 seconds, the battery level indicator will be displayed by numbers 1-4 as per figure 1.1 (refer p16) or alternatively, the display may show the letter 'C'. **Keep pressing & only release your finger once the display screen has turned off as per fig 1.2 (5 seconds)**. The red ring light on the battery will now be off.
- You have now successfully turned off the battery & the buggy.



STEP 2:

- Disconnect the electrical lead from the battery by gently pulling out the lead as indicated in fig 2.



STEP 3:

- Lift battery up out of it's mounting points. You are now ready to pack down the buggy.



FIGURE 4

STEP 4:

- Tilt buggy back & lift up on front wheel release lever as indicated by yellow arrow in figure 4.



FIGURE 5

STEP 5:

- Fold front wheel up towards the frame until it is in the locked position as per figure 6.



FIGURE 6

STEP 6:

- The front wheel is now in the fully locked position.



FIGURE 7

STEP 7:

- Unlock the top handle by pushing down on the lever as indicated by the yellow arrow in figure 4 until the handle is in the fully closed position as per figure 5.



FIGURE 8

STEP 8:

- Push down on the handle assembly in the direction of the yellow arrow to fully collapse the buggy as per figure 6.



FIGURE 9

STEP 9:

- The buggy is now in the fully closed position.



FIGURE 10

STEP 10:

- Push down on upper bag support until it is tucked up under the handle assembly as per figure 11.



FIGURE 11

STEP 11:

- Lock the top handle to complete the pack down procedure.



FIGURE 12

STEP 12:

- You have now successfully completed the pack down procedure.

DEPLOYING THE BUGGY STAND

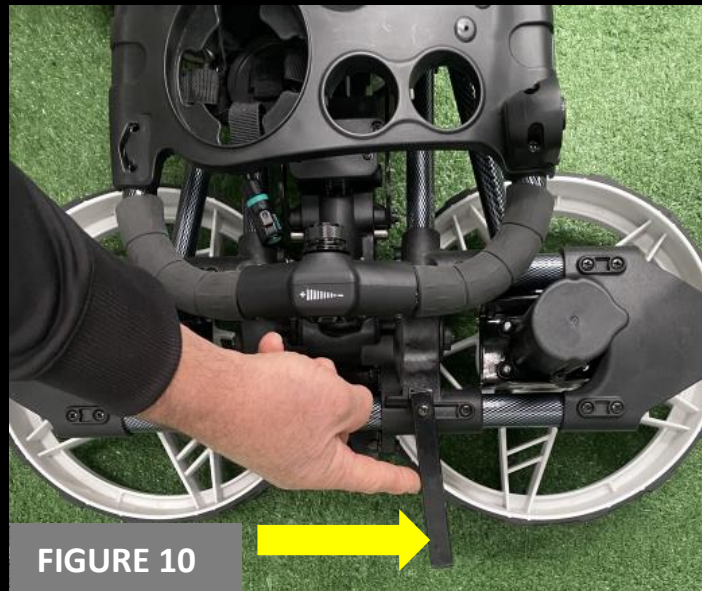

FIGURE 10

STEP 10:

- Rotate the black stand to enable the buggy to stand upright.



FIGURE 11

STEP 11:

- The buggy is now standing in the correct position.

STINGER

GOLF PRODUCTS



INFO@STINGERGOLF.COM.AU



11/6 Thomson Terrace,
Dromana VIC 3936



WWW.STINGERGOLF.COM.AU



03 5924 6056