

Elite Screens - Line drawing and dimension table
ezCinema plus 2 series
V03182024AZ

Unit: mm																	Packing dimension				
Model	Screen Diagonal	Aspect Ratio	Screen material	Case L (A)	Screen W (A2)	View W (A1)	Top bar length (A3)	L/R black masking border (A4)	Overall H (B)	View H (B1)	Screen H (B2)	Bottom black masking boarder (B3)	End Cap W (C)	(C1)	(C2)	End Cap H (D)	G.W (KGS)	N.W. (KGS)	L (mm)	W (mm)	H (mm)
F70XWH2	70"	16:9	MaxWhite 2	1800	1650	1550	1768	50	1800	872	1700	768	128	410	190	102	11,60	9,00	1865	195,00	160,00
F84XWH2	84"	16:9	MaxWhite 2	2099	1960	1860	2067	50	1800	1046	1700	594	128	410	190	102	13,40	10,40	2155	195,00	160,00
F95XWH2	95"	16:9	MaxWhite 2	2353	2203	2103	2321	50	1800	1183	1700	457	128	410	190	102	14,40	11,30	2400	195,00	160,00
F107XWH2	107"	16:9	MaxWhite 2	2619	2469	2369	2587	50	2100	1333	2000	607	128	410	190	102	17,10	13,90	2767	195,00	160,00
F110NWX2	110"	16:10	MaxWhite 2	2619	2469	2369	2587	50	2100	1484	2000	456	128	410	190	102	17,10	13,90	2767	195,00	160,00
F52XWV2	52"	4:3	MaxWhite 2	1307	1157	1057	1275	50	1500	792	1400	548	128	410	190	102	9,00	6,90	1370	195,00	160,00
F84XWV2	84"	4:3	MaxWhite 2	1957	1807	1707	1925	50	2100	1280	2000	660	128	410	190	102	13,00	10,40	2019	195,00	160,00
F100XWV2	100"	4:3	MaxWhite 2	2307	2132	2032	2275	50	2100	1524	2000	416	128	410	190	102	15,60	12,50	2373	195,00	160,00
F120NWX2	120"	4:3	MaxWhite 2	2688	2538	2438	2656	50	2400	1829	2300	411	128	410	190	102	18,40	15,30	2752	195,00	160,00

Unit: inch																	Packing dimension				
Model	Screen Diagonal	Aspect Ratio	Screen material	Case L (A)	Screen W (A2)	View W (A1)	Top bar length (A3)	L/R black masking border (A4)	Overall H (B)	View H (B1)	Screen H (B2)	Bottom black masking boarder (B3)	End Cap W (C)	(C1)	(C2)	End Cap H (D)	N.W (LBS)	G.W. (LBS)	L (inch)	W (inch)	H (inch)
F70XWH2	70"	16:9	MaxWhite 2	70,9	65,0	61,0	69,6	2,0	70,9	34,3	66,9	30,2	5,0	16,1	7,5	4,0	25,57	19,84	73,43	7,68	6,30
F84XWH2	84"	16:9	MaxWhite 2	82,6	77,2	73,2	81,4	2,0	70,9	41,2	66,9	23,4	5,0	16,1	7,5	4,0	29,53	22,92	84,84	7,68	6,30
F95XWH2	95"	16:9	MaxWhite 2	92,6	86,7	82,8	91,4	2,0	70,9	46,6	66,9	18,0	5,0	16,1	7,5	4,0	31,74	24,91	94,49	7,68	6,30
F107XWH2	107"	16:9	MaxWhite 2	103,1	97,2	93,3	101,9	2,0	82,7	52,5	78,7	23,9	5,0	16,1	7,5	4,0	37,69	30,64	108,94	7,68	6,30
F110NWX2	110"	16:10	MaxWhite 2	103,1	97,2	93,3	101,9	2,0	82,7	58,4	78,7	18,0	5,0	16,1	7,5	4,0	37,69	30,64	108,94	7,68	6,30
F52XWV2	52"	4:3	MaxWhite 2	51,5	45,5	41,6	50,2	2,0	59,1	31,2	55,1	21,6	5,0	16,1	7,5	4,0	19,84	15,21	53,94	7,68	6,30
F84XWV2	84"	4:3	MaxWhite 2	77,0	71,1	67,2	75,8	2,0	82,7	50,4	78,7	26,0	5,0	16,1	7,5	4,0	28,65	22,92	79,49	7,68	6,30
F100XWV2	100"	4:3	MaxWhite 2	90,8	83,9	80,0	89,6	2,0	82,7	60,0	78,7	16,4	5,0	16,1	7,5	4,0	34,38	27,55	93,43	7,68	6,30
F120NWX2	120"	4:3	MaxWhite 2	105,8	99,9	96,0	104,6	2,0	94,5	72,0	90,6	16,2	5,0	16,1	7,5	4,0	40,55	33,72	108,35	7,68	6,30

Note:Data Error ±1"

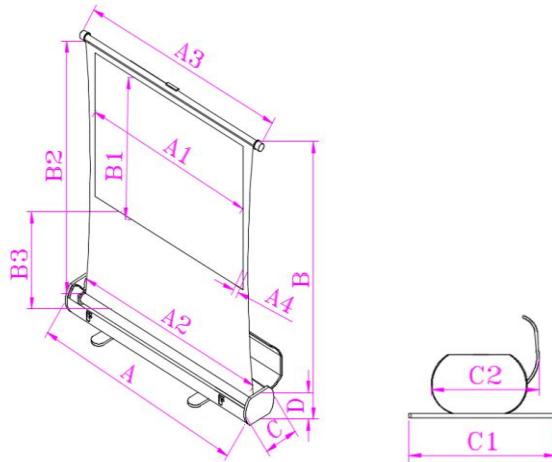

Elite Screens - Line drawing and dimension table
 ezCinema plus Tab-Tension 2 series
 V03182024AZ

Unit: mm																	Packing dimension				
Model	Screen Diagonal	Aspect Ratio	Screen material	Case L (A)	Screen W (A2)	View W (A1)	Top bar length (A3)	L/R black masking border (A4)	Overall H (B)	View H (B1)	Screen H (B2)	Bottom black masking boarder (B3)	End Cap W (C)	(C1)	End Cap H (D)	G.W. (KGS)	N.W. (KGS)	L (mm)	W (mm)	H (mm)	
FT80XWH	80"	16:9	MaxWhite 2	2041	1831	1771	2009	30	1800	996	1700	644	128	410	190	102	13,50	10,60	2100	195	160
FT92XWH	92"	16:9	MaxWhite 2	2307	2097	2037	2275	30	1800	1146	1700	494	128	410	190	102	14,50	11,20	2360	195	160
FT110XWH	110"	16:9	MaxWhite 2	2700	2495	2435	2668	30	2100	1370	2000	570	128	410	190	102	16,70	12,90	2752	195	160
FT90XWV	90"	4:3	MaxWhite 2	2099	1889	1829	2067	30	2100	1372	2000	568	128	410	190	102	14,20	11,00	2155	195	160
FT100XWV	100"	4:3	MaxWhite 2	2307	2092	2032	2275	30	2100	1524	2000	416	128	410	190	102	15,60	12,50	2373	195	160

Unit: inch																	Packing dimension				
Model	Screen Diagonal	Aspect Ratio	Screen material	Case L (A)	Screen W (A2)	View W (A1)	Top bar length (A3)	L/R black masking border (A4)	Overall H (B)	View H (B1)	Screen H (B2)	Bottom black masking boarder (B3)	End Cap W (C)	(C1)	End Cap H (D)	N.W. (LBS)	G.W. (LBS)	L (inch)	W (inch)	H (inch)	
FT80XWH	80"	16:9	MaxWhite 2	80,4	72,1	69,7	79,1	1,2	70,9	39,2	66,9	25,3	5,0	16,1	7,5	4,0	29,75	23,36	82,68	7,68	6,30
FT92XWH	92"	16:9	MaxWhite 2	90,8	82,5	80,2	89,6	1,2	70,9	45,1	66,9	19,5	5,0	16,1	7,5	4,0	31,96	24,68	92,91	7,68	6,30
FT110XWH	110"	16:9	MaxWhite 2	106,3	98,2	95,9	105,0	1,2	82,7	53,9	78,7	22,4	5,0	16,1	7,5	4,0	36,81	28,43	108,35	7,68	6,30
FT90XWV	90"	4:3	MaxWhite 2	82,6	74,4	72,0	81,4	1,2	82,7	54,0	78,7	22,4	5,0	16,1	7,5	4,0	31,30	24,24	84,84	7,68	6,30
FT100XWV	100"	4:3	MaxWhite 2	90,8	82,4	80,0	89,6	1,2	82,7	60,0	78,7	16,4	5,0	16,1	7,5	4,0	34,38	27,55	93,43	7,68	6,30

Note:Data Error ±1"

