

USER MANUAL

Runaway®

STEREO BLUETOOTH®
WIRELESS HEADPHONES

model: AF32

MEE audio™
MUSIC ENJOYMENT FOR EVERYONE

PACKAGE CONTENTS



Runaway AF32
Stereo Bluetooth
Wireless Headphones



Charging cable
(USB – 3.5mm)



Stereo audio cable
(3.5mm – 3.5mm)



Carrying pouch



User manual

PRODUCT OVERVIEW

Runaway

Stereo Bluetooth
Wireless Headphones

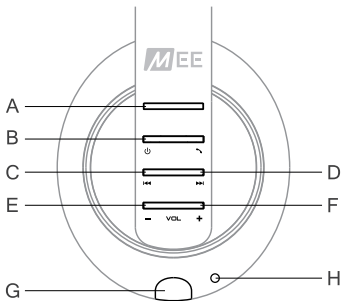

RIGHT EAR CUP

- A LED indicator light
- B Multifunction button (⏻ / 📞)
- C Previous track button (⏮)
- D Next track button (⏭)
- E Volume down button (—)
- F Volume up button (+)
- G Headphone / charging jack
- H Microphone

CHARGING

***** You must completely charge the headphones before the first use *****

Connect the USB charging cable to any powered USB port and to the 3.5mm jack on the right earcup. Make sure it is plugged in fully. Charge time is typically 2-3 hours.

The red LED light will stay lit while the headphones are charging and will blink or turn off completely when the headphones are ready for use. A blinking red LED light indicates a trickle charge mode, whereby the battery is charged almost fully and the headphones are maintaining their current charge level.

Note: the Runaway cannot be turned on or used while charging.

INDICATOR LIGHT STATE WHEN CHARGING CABLE IS PLUGGED IN:

LIGHT PATTERN	STATUS	NOTES
Solid red light	Battery charging	Allow to charge for 2-3 hours
Blinking red light	Trickle charge	Ready for use
All lights off	Battery full	Ready for use

When the battery is low, the headphones will say "Battery low" every 60 seconds and the red light will flash three times every three seconds.

Apple® devices such as the iPhone®, iPad®, and iPod® Touch will display a headphone battery indicator when the Runaway is connected.

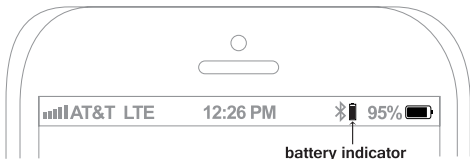

TURNING ON AND OFF

To turn on, press and hold the Multifunction button for approximately 3 seconds. The headphones will say "Power on" and the blue LED light will flash.

To turn off, press and hold the Multifunction button for approximately 4 seconds. The headphones will say "Power off" and the red LED light will flash.

PAIRING WITH BLUETOOTH DEVICES

***** Your headphones must be paired to a Bluetooth device before they can be used. It is only necessary to pair your headphones once with each device. *****

- 1) Open the Bluetooth menu on the device you wish to pair (see **Locating the Bluetooth Menu** on page 5 for more details). Some devices require you to select "Search for Devices" or "Add New Device" in order to create a Bluetooth pairing.
- 2) With the headphones turned off, press and hold the Multifunction button for approximately 6 seconds until the headphones say "Pairing". The red and blue LED lights will flash in an alternating pattern while the Runaway is in pairing mode. (Note: The Runaway will enter standby mode if not paired within 90 seconds.)
- 3) Wait until you see "MEE audio Runaway" on your device screen.
- 4) Select "MEE audio Runaway" on your device and follow any further prompts to pair. Use "0000" if a pin is required. Once pairing is complete and a connection is established, the blue LED light will flash several times.

LOCATING THE BLUETOOTH MENU

iPhone, iPad, and iPod Touch

- a) On your device, go to **Settings**
- b) Select **Bluetooth**. If Bluetooth is not on, turn it on.
The iPhone/iPad/iPod will automatically search for new devices

Android™ Phones and Tablets

- a) On your device, go to the **Settings** menu
- b) Select **Bluetooth** (on older Android devices Bluetooth is found in the **Wireless & Networks** menu). If Bluetooth is not on, turn it on.
Select "Search for Devices" if your phone or tablet does not automatically search for new devices

Windows® Phone 8 Devices

- a) On your device, open the **Settings** menu
- b) Select **Bluetooth**. If Bluetooth is not on, turn it on.
The Windows phone will automatically search for new devices

Computers, Laptops, and Other Devices

Visit the Bluetooth Support Page at www.MEEaudio.com for pairing and setup information.

If pairing fails after several tries, please refer to your device's user manual for further information. Visit the Bluetooth Support Page at www.MEEaudio.com for instructional pairing videos and troubleshooting information.

CONNECTING WITH PAIRED DEVICES

Once the Runaway is turned on, it will automatically connect with the last paired Bluetooth device that is on and within range. If the Runaway is not connected automatically, tap the multifunction button once to initiate connection with last paired device. If the headphones still do not connect, open the Bluetooth menu on your device and select "MEE audio Runaway" from the Bluetooth device list.

On some computers, Bluetooth audio must be enabled manually every time you connect.

CONTROLS

The Runaway can control media and phone calls from a smartphone or tablet.

1. ADJUSTING THE VOLUME

FUNCTION	OPERATION	NOTES
Increase volume	Press the Volume Up button	When the volume reaches the minimum or maximum level the Runaway will produce a short tone.
Decrease volume	Press the Volume Down button	

Note: Volume can be adjusted only while media is playing or during a phone call. With most devices, volume adjustments will change the volume of the headphones independently of the connected device while playing media. Adjust device volume as needed to further increase or decrease the volume. During a phone call the headphones will directly control device volume.

2. CONTROLLING PHONE CALLS

STATUS	FUNCTION	OPERATION
Incoming call	Answer call	Press the Multifunction button
	Reject call	Double press the Multifunction button
Call in progress	End call	Press the Multifunction button
	Transfer call between headphones and phone*	Press and hold the Multifunction button for 2 seconds until you hear a tone
	Mute / unmute call	Double press the Multifunction button to mute; double press again to unmute

(continues on page 7)

CONTROLS (CONTINUED)

2. CONTROLLING PHONE CALLS (CONTINUED)

STATUS	FUNCTION	OPERATION
Call in progress, second incoming call	Answer new call and put current call on hold	Press the Multifunction button
	Reject incoming call	Double press the Multifunction button
One call active, one on hold	Switch active calls	Press and hold the Multifunction button for 2 seconds until you hear a tone
	End current call and switch to call on hold	Press the Multifunction button

*If you answer an incoming call from your phone instead of the headphones, most phones will activate the phone speaker. Press and hold the Multifunction button for 2 seconds to transfer the call to the headphones.

3. CONTROLLING MEDIA PLAYBACK

STATUS	FUNCTION	OPERATION
No media playing*	Play media	Press the Multifunction button
Media playing	Pause media playback	Press the Multifunction button
Media playing or paused	Skip to next track**	Press the Next Track button
	Restart track / previous track**	Press the Previous Track button

*You may need to focus on the media player application by bringing it up on the screen for initial playback to start.

** Not all media players support this functionality.

Note: If you answer or make a call while listening to media, the media will be paused until the call has ended.

(continues on page 8)

CONTROLS (CONTINUED)

4. ADDITIONAL FUNCTIONALITY

FUNCTIONALITY	OPERATION	NOTES
Redial last call*	Double press the Multifunction button when no call is in progress	Headphones will say "Last number redial"
Activate Siri®/ voice command/ voice dialing*	Press and hold the Multifunction button for 2 seconds	Headphones will produce a tone and media will be paused. Press and hold Multifunction button for 2 seconds again to cancel.
Battery meter	Press the volume up or volume down button when the unit is in standby mode (no media playing/ no active phone calls)	Headphones will provide approximate battery state as either "Battery high", "Battery medium", or "Battery low"

*Not all devices support this functionality. For more information, refer to the user manual for your device.

MULTIPOINT

Multipoint allows two Bluetooth devices to be connected to the Runaway simultaneously, providing additional flexibility for your multimedia experience.

1. MULTIPOINT PAIRING

To use two Bluetooth devices with the Runaway, first pair them by following the pairing procedure described in the **Pairing with Bluetooth Devices** section on Page 4 for each device and then turn off the headphones. Both devices will need to be paired before multipoint can be used.

When turned on again, the Runaway will automatically attempt to connect to the 2 most recently-paired devices, as long as they have Bluetooth enabled and are within range. If a device that has already been paired does not connect automatically, select "MEE audio Runaway" from the Bluetooth menu of the device.

If you no longer wish to connect to multiple devices, disable Bluetooth on the device you do not want connected to the Runaway or remove the "MEE audio Runaway" pairing from the Bluetooth menu of the device.

(continues on page 10)

MULTIPOINT (CONTINUED)

2. MULTIPOINT FUNCTIONALITY

STATUS	FUNCTION	OPERATION
Media playing on one device	Play media on other device	Pause audio playback on the active device and start audio playback on the other connected device. It may take up to 10 seconds for audio to switch
Incoming call	Answer call	Short press the Multifunction button
	Reject call	Double press the Multifunction button
	Mute / unmute call	Double press the Multifunction button
Call in progress, second incoming call	Answer new call and put current call on hold	Press the Multifunction button
	Reject incoming call	Double press the Multifunction button
One call active, one on hold	Switch active calls	Press and hold the Multifunction button for 2 seconds until you hear a tone
	End current call and switch to call on hold	Press the Multifunction button

Note: Incoming calls will always take precedence over other audio. If two phones are connected to the Runaway, an incoming call on either phone will trigger an alert and media playback will be paused if the call is answered. Once the call is terminated, the Runaway will reactivate the original device and resume playback (with most media applications).

USE AS WIRED HEADPHONE

The Runaway can be used as a wired headphone by plugging one end of the included stereo audio cable into the 3.5mm jack on the Runaway and the other end into any audio device with a standard 3.5mm headphone jack. Plugging the audio cable into the headphone will disable Bluetooth functionality until the cable is unplugged.

Note: the built-in microphone of the Runaway will not work when the headphones are used in wired mode.

SAFETY AND CARE

- When not in use, power the headphones off and store in a cool, dry place. Battery performance will be severely decreased when stored in extreme temperatures: below $-10^{\circ}\text{C}/14^{\circ}\text{F}$ or above $45^{\circ}\text{C}/113^{\circ}\text{F}$ including direct sunlight.
- Clean with a soft cloth, damp with diluted soap water solution if necessary. Never use chemical cleaners.
- There are no user replaceable/repairable parts in the headphone. Disassembling it will void your warranty.
- Do not expose the headphones to liquids. If the device comes in contact with liquids, quickly wipe away. If submerged in water, do not turn the device on until completely dried. Note: liquid submersion voids the warranty.
- Do not use around flammable gasses as fire or explosion may occur
- Replacement parts and accessories are available online at www.MEEaudio.com

WARNING:

Using headphones at high to moderate volumes for extended periods of time will result in permanent hearing damage. It is advised you keep volume levels moderate to low at all times for your safety. Do not use while driving a car, cycling, operating machinery, or performing other activities that require hearing surrounding sounds.

It is advised to turn the volume on your device all the way down before connecting your headphones, then gradually increase the volume until you reach a comfortable listening level.

SPECIFICATIONS

Bluetooth Version	4.0
Bluetooth Profiles Supported	A2DP, HSP, HFP, AVRCP
Driver	40 mm dynamic driver
Frequency Response	20Hz to 20kHz
Operating Range	10 m (30 ft)
Music Playback Time	15 hrs
Talk Time	15 hrs
Standby Time	150 hrs

TROUBLESHOOTING

Visit the Bluetooth Support Page at www.MEEaudio.com for troubleshooting procedures.

WARRANTY

The Runaway is covered by a 1 year manufacturer warranty. For more information, visit www.MEEaudio.com

NOTES

Have a question?
Email support@meelec.com



MEE audio and its logo are registered trademarks of S2E, Inc. All rights reserved.

iPhone®, iPad®, iPod®, iPod touch®, and Siri® are registered trademarks of Apple Inc.

Android™ is a registered trademark of Google Inc.

Windows® Phone is a registered trademark of Microsoft Corporation in the United States and other countries.

The Bluetooth® word mark and logos are registered trademarks owned by Bluetooth SIG, Inc.

and any use of such marks by **MEE audio** is under license. Other trademarks and trade names are those of their respective owners.



www.MEEaudio.com
support@meelec.com