



# GM8224S008

Lo-Cog® DC Gearmotor

Assembly Data	Symbol	Units	Value	
Reference Voltage	E	V	12	
No-Load Speed	S <sub>NL</sub>	rpm (rad/s)	720	(75.4)
Continuous Torque (Max.) <sup>1</sup>	T <sub>C</sub>	oz-in (N-m)	15	(1.0E-01)
Peak Torque (Stall) <sup>2</sup>	T <sub>PK</sub>	oz-in (N-m)	42	(3.0E-01)
Weight	W <sub>M</sub>	oz (g)	8.2	(231)
Motor Data				
Torque Constant	K <sub>T</sub>	oz-in/A (N-m/A)	3.09	(2.18E-02)
Back-EMF Constant	K <sub>E</sub>	V/krpm (V/rad/s)	2.29	(2.18E-02)
Resistance	R <sub>T</sub>	Ω	4.33	
Inductance	L	mH	2.34	
No-Load Current	I <sub>NL</sub>	A	0.18	
Peak Current (Stall) <sup>2</sup>	I <sub>P</sub>	A	2.77	
Motor Constant	K <sub>M</sub>	oz-in/√W (N-m/√W)	1.49	(1.05E-02)
Friction Torque	T <sub>F</sub>	oz-in (N-m)	0.35	(2.5E-03)
Rotor Inertia	J <sub>M</sub>	oz-in-s <sup>2</sup> (kg-m <sup>2</sup> )	2.3E-04	(1.6E-06)
Electrical Time Constant	τ <sub>E</sub>	ms	0.54	
Mechanical Time Constant	τ <sub>M</sub>	ms	14.7	
Viscous Damping	D	oz-in/krpm (N-m-s)	0.020	(1.4E-06)
Damping Constant	K <sub>D</sub>	oz-in/krpm (N-m-s)	1.6	(1.1E-04)
Maximum Winding Temperature	θ <sub>MAX</sub>	°F (°C)	311	(155)
Thermal Impedance	R <sub>TH</sub>	°F/watt (°C/watt)	70.5	(21.4)
Thermal Time Constant	τ <sub>TH</sub>	min	10.7	
Gearbox Data				
Reduction Ratio			6.3	
Efficiency <sup>3</sup>			0.95	
Maximum Allowable Torque		oz-in (N-m)	100	(0.71)
Encoder Data				

1 - Specified at max. winding temperature at 25°C ambient without heat sink. 2 - Theoretical values supplied for reference only.  
 3 - Effective gearbox efficiency for this unit improved by use of ball bearings.

- ### Included Features
- 2-Pole Stator
  - Ceramic Magnets
  - Heavy-Gauge Steel Housing
  - 7-Slot Armature
  - Silicon Steel Laminations
  - Stainless Steel Shaft
  - Copper-Graphite Brushes
  - Diamond Turned Commutator
  - Motor Ball Bearings
  - Output Ball Bearing
  - Standard Gears

- ### Customization Options
- Alternate Winding
  - Sleeve or Ball Bearings
  - Modified Output Shaft
  - Custom Cable Assembly
  - Special Brushes
  - EMI/RFI Suppression
  - Alternate Gear Material
  - Special Lubricant
  - Optional Encoder
  - Fail-Safe Brake

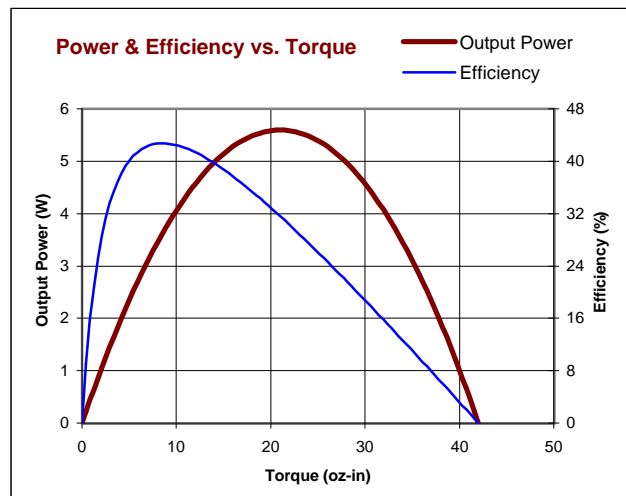
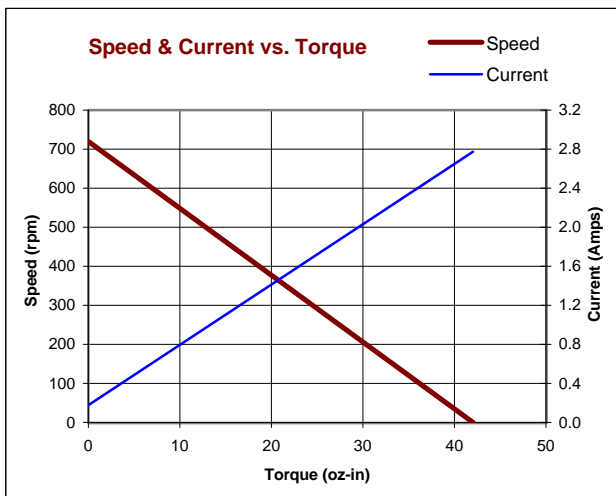

All values are nominal. Specifications subject to change without notice. Graphs are shown for reference only.

© 2001 Pittman.

# UNCONTROLLED

NOTICE: CONFIDENTIAL PROPRIETARY INFORMATION THIS PRINT CONTAINS IDEAS, INFORMATION, AND INTELLECTUAL PROPERTY WHICH ARE THE EXCLUSIVE PROPERTY OF PITTMAN, DIVISION OF PENN ENGINEERING & MANUFACTURING CORP. RECIPIENT MUST KEEP THE INFORMATION DISCLOSED HEREIN CONFIDENTIAL AND RECIPIENT IS EXPRESSLY PROHIBITED FROM COPYING OR PUBLICATION OF THIS PRINT EXCEPT TO OTHERS IN THEIR ORGANIZATION ON A NEED-TO-KNOW BASIS

REVISIONS				
LTR	DESCRIPTION	DRFT/ENGR	DATE	APPR
H	REDRAWN, UPDATED TO CURRENT STD.	DLF	6/28/94	JVM
J	UPDATED TO CURRENT STD.	RJS/RJS		

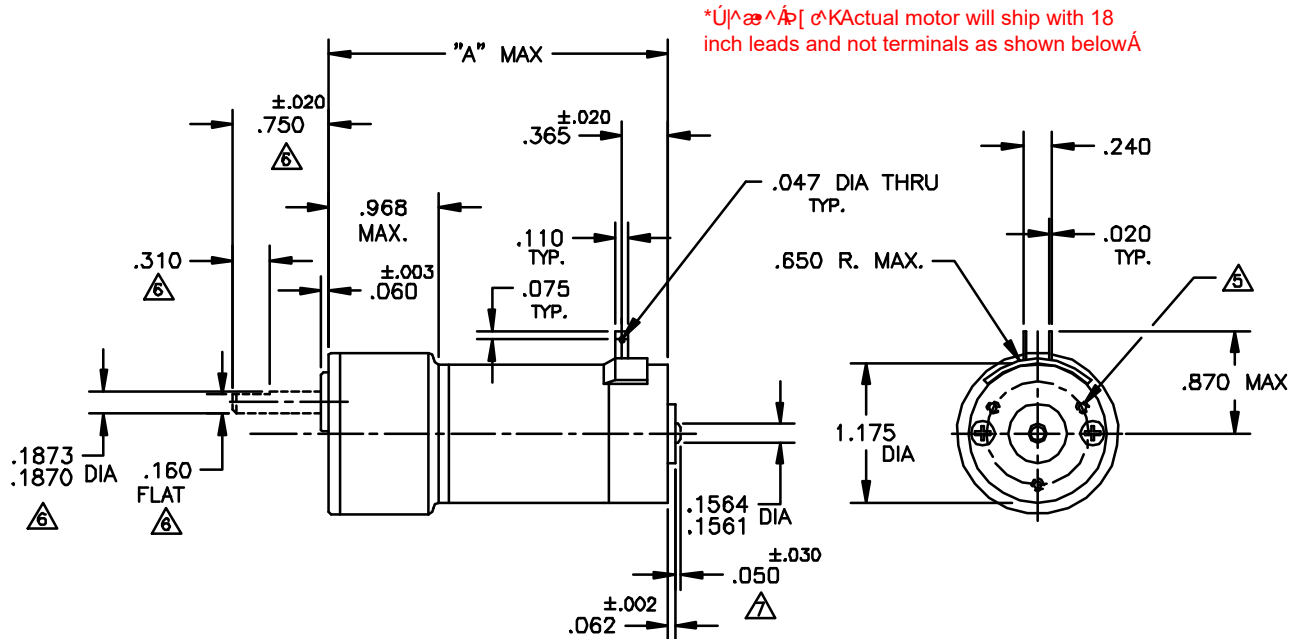
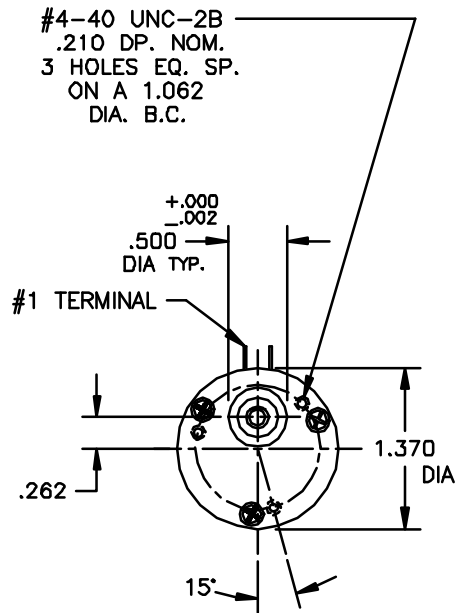

**NOTES:**

- SHAFT ROTATION IS SHOWN WHILE VIEWING MOUNTING END, WITH POSITIVE (+) VOLTAGE APPLIED TO # 1 TERMINAL.
  - TERMINALS ARE PLATED FOR SOLDERING.
  - MAX. GEARBOX TORQUE RATING IS 100 OZ.IN., STANDARD SINTERED GEARS. MAX. GEARBOX TORQUE RATING IS 160 OZ.IN., CUT STEEL GEARS.
  - ENDPLAY .020 MAX. ON OUTPUT SHAFT, .015 MAX. ON MOTOR SHAFT.
- OPTIONAL MOUNTING PATTERN #2-56 UNC-2B, (3) HOLES EQUALLY SPACED ON A .875 DIA. B.C., .125 MAX. THREAD DEPTH.
- ALL SHAFT DIMENSIONS SHOWN ARE STD. (10-385). FOR ALL OTHER CONFIGURATIONS REFER TO DATA SHEET FOR PART NUMBERS.
- OPTIONAL REAR SHAFT EXTENSIONS AVAILABLE.

GEAR RATIO	DIRECTION		
187/96:1	CCW	3.285	GM87X4
60.5/31:1	CW	3.035	GM87X3
19.5/10:1	CCW	2.910	GM87X2
6.3:1	CW	"A" MAX.	MODEL NO.

UNLESS OTHERWISE SPECIFIED DIMENSIONS ARE IN INCHES TOLERANCES ARE: FRACTION DECIMAL ANGLES ±1/64 .015 ±1° XX ±0.015 XXX ±0.005 BREAK ALL SHARP EDGES	FILE: 150/28	
	DRAFTED BY: DLF DATE: 6/24/94	
MATERIAL:	ENGINEERED BY: DLF 6/24/94	DWG. NO. B-150-28
FINISH:	APPROVED BY: JVM 6/28/94	REV. J
	NEXT ASSY:	SCALE: D.N.S. SHEET 1 OF 1
	USED ON:	