

Product Details

Brush DC Motor 9237S011-R1-SP

Note: Product photo is for illustrative purposes. Please refer to Engineering Drawing for specifics.



Motor Series	Series 9000 LO-COG Brush Commutated DC Motors
Frame Size (Mounting Face) (in)	1.58
Motor Frame Size (in)	1.58
Gear Frame Size (in)	n/a
Overall Body Length (in)	4.016
Supply Voltage (V)	24
Continuous Output Torque (oz-in)	12
Output Speed @ Cont. Torque (RPM)	4370
Current @ Cont. Torque (A)	2.4
Continuous Output Power (W)	37
No Load Current (A)	0.18
No Load Output Speed (RPM)	5230
Peak Current (A)	13
Peak Output Torque (oz-in)	77
Motor Constant (oz-in/√W)	4.41
Motor Torque Constant (oz-in/A)	6
Motor Voltage Constant (V/krpm)	4.44
Terminal Resistance (Ohms)	1.85
Inductance (mH)	2
Coulomb Friction Torque (oz-in)	0.8
Viscous Damping Factor (oz-in/krpm)	0.055
Electrical Time Constant (ms)	1.1
Mechanical Time Constant (ms)	8.7
Thermal Time Constant (min)	14
Thermal Resistance (°C/Watt)	11
Maximum Winding Temperature (°C)	155
Rotor Inertia (oz-in-s ²)	0.0012
Output Bearing	Ball
Gear Series	n/a
Gear Ratio (xx.x:1)	n/a
Gear Type	n/a
Gear Efficiency	n/a
Gear Maximum Torque (oz-in)	n/a
Encoder Series	E30B
Encoder Resolution (CPR)	500
Encoder Output Channels	3
Weight (Mass) (oz)	18
Voltage Note	n/a
Torque Warning	n/a

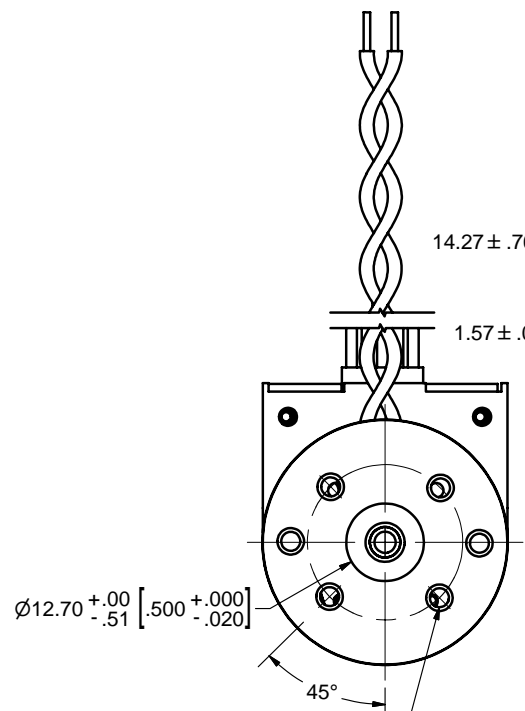

#6-32 UNC-2B
 8.89[.350] DP. MAX.
 SCREW PENETRATION
 (4) HOLES EQ. SP.
 ON A $\varnothing 25.4[1.000]$ B.C.

