

Foot Switch Valve

How It Works

The Rayzist Foot Switch Valve has replaced the Top & Bottom Footswitch Valve and Diaphragm gasket. FSV tube sleeve is controlled by pneumatic unregulated pressure supplied from compressor (no less than 80PSI recommended). The Air Inlet Pressure closes the sleeve bubble tight around the center core (when foot pedal is not depressed). When foot pedal is depressed the valve simply exhaust the inlet pressure.

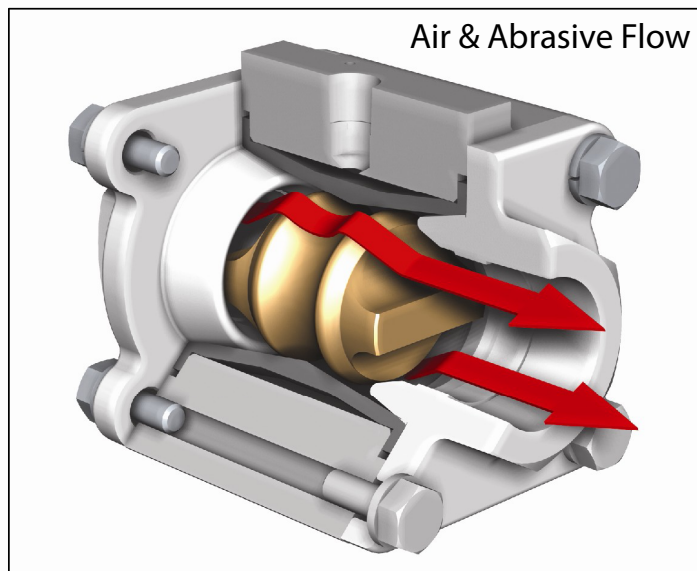

Air & Abrasive Flow

Easy to service design, simply remove the end caps and replace the only moving part in the valve, the sleeve and core FSVKIT.

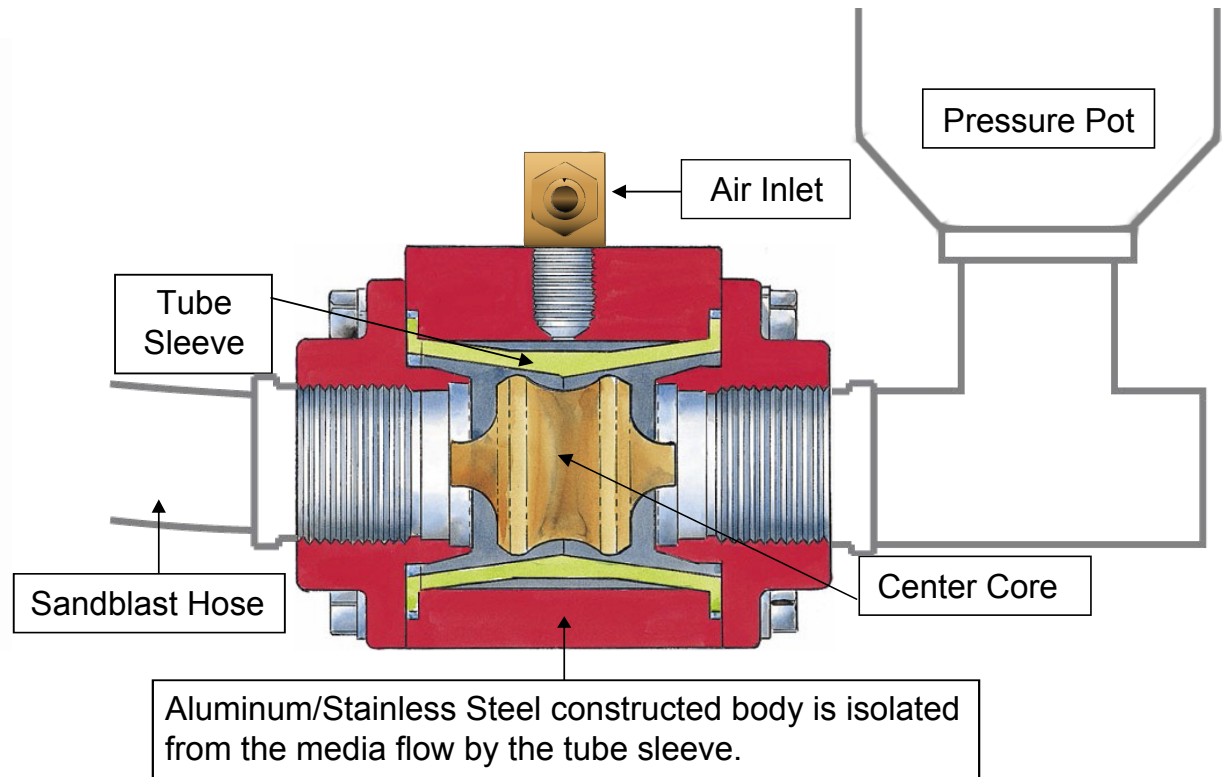

INSTALLATION INSTRUCTIONS:

1. Install Foot Switch Valve between pressure pot and sandblast hose, use existing 1/2" close nipple.
2. Thread on the new bi-directional FSV.
3. The Foot Pedal "Air Inlet" male quick disconnect should be facing forward after install.

Check [youtube.com/sandcarving](https://www.youtube.com/sandcarving) for more information.

Rayzist Photomask, Inc.

1-800-729-9478 www.rayzist.com