

# 1020 Self-Propelled Washout System

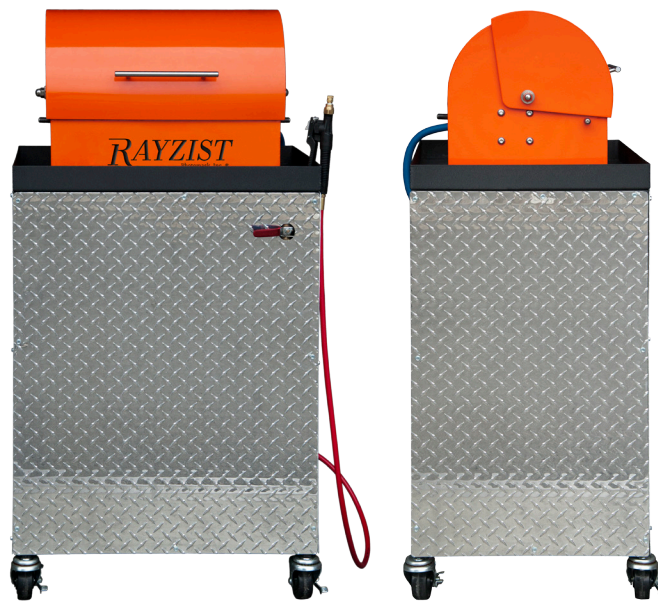

## Set-Up Guide

# 1020 Washout System

The 1020 Washout System is specifically designed to run solely off of water pressure provided from your own water supply. The greater the pressure, the faster your rinse result.

**Minimum line pressure 40 PSI.**

Ideal incoming line pressure 65 PSI.

**Greater than 110 ° F (43 ° C) water recommended for best results.**

Wash times vary depending on water pressure and temperature.

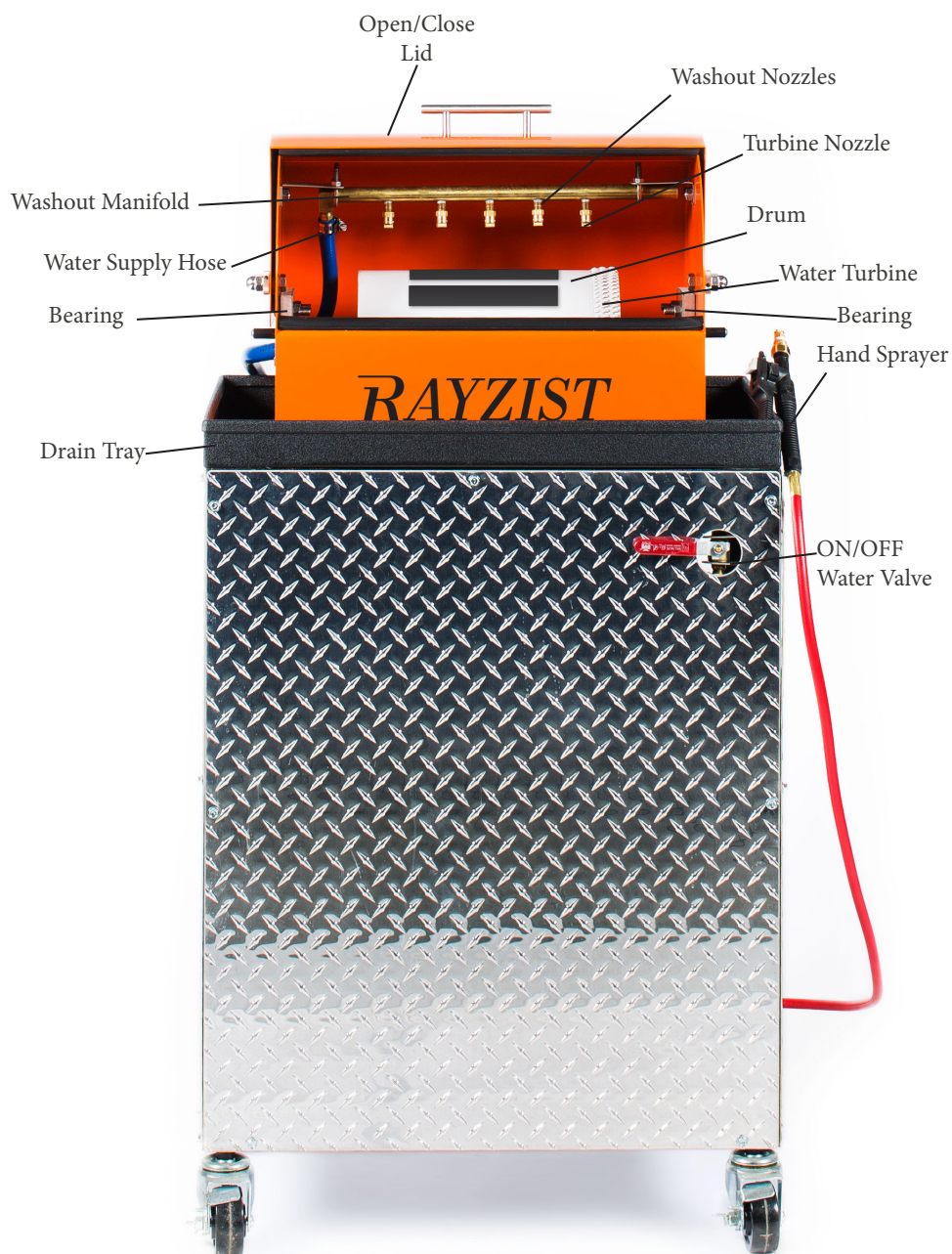

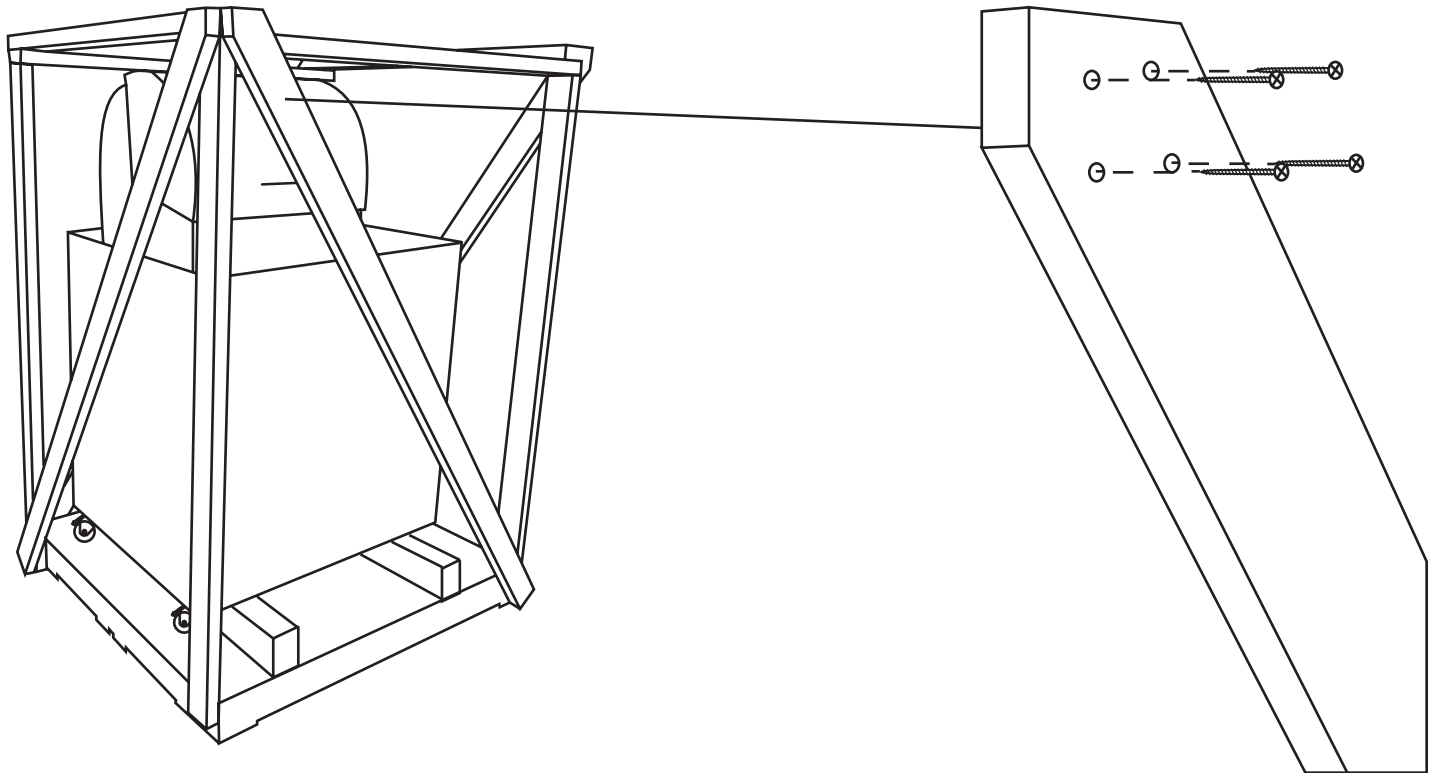

# Unloading

Items Needed: *Philips-head Screwdriver and Clippers or Tin Snips*

1. Use a screwdriver to remove wood screws from the back brace of the crate.
2. Cut band with clippers or tin snips.
3. Move the 1020 Washout System back and forth moving toward end of pallet until the front/back two wheels are at the edge of the pallet.
4. Move the 1020 Washout System until the two wheels touch the floors. Once the front/back two wheels are touching the floor, roll the system off the pallet to the floor.
5. Roll the system to the area that it will be set up in.

## CAUTION

The 1020 Washout System weighs approximately 95 lbs. It is advised that 2 or more people unload it.

Tin snips or clippers are very useful in removing the metal bands from the crate. Please use caution when removing the bands because the bands are under high tension and may snapback.

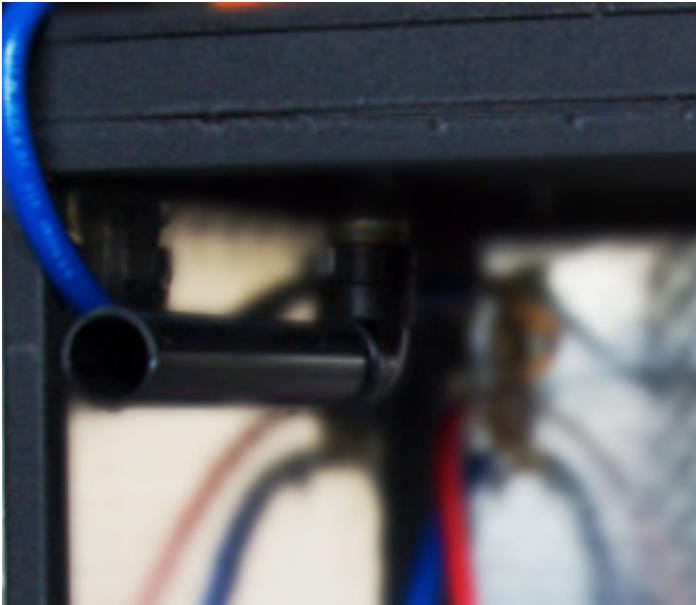

1.5" PVC Drain



3/4" Female GHT (Garden Hose Thread) Fitting

# Set Up

1. Connect to 1.5" supply drain with flexible drain hose or coupler.

**Note:** Drain can be installed to current drain system, utility sink or outside.

2. Connect hot water supply to 3/4" female GHT (Garden Hose Thread) water inlet. It is recommended that you turn OFF external water supply when not in use.

**Note:** Warm to hot water is recommended for best results. Also remember that the water pressure should not go below 40 psi.

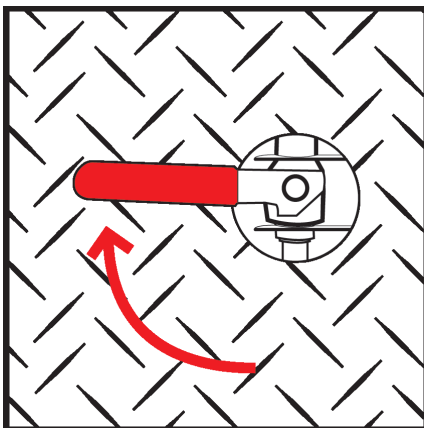

Closed "OFF"

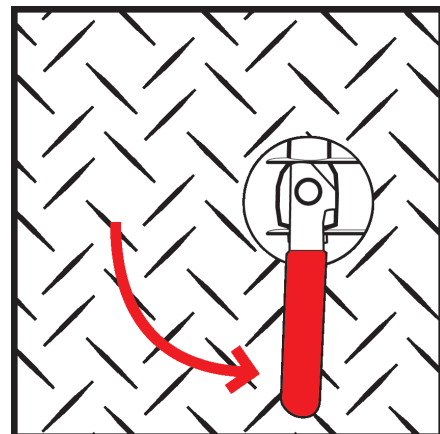

Open "ON"

# Operation

Before operation, turn ON the water valve to confirm that there is adequate water pressure to make the drum spin. Ideal water temperature is 110-130 °F. This is only recommended for quicker rinse times. Cold water will work but the washout cycle will take longer.

1. Place the exposed SR3000™ photoresist sheet with the shiny side down on drum. Place magnets with the smooth side against drum.

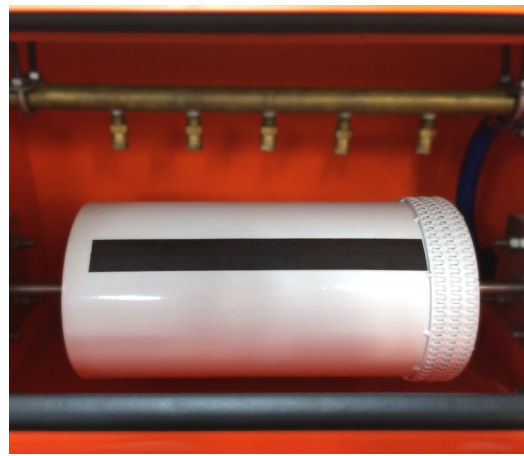
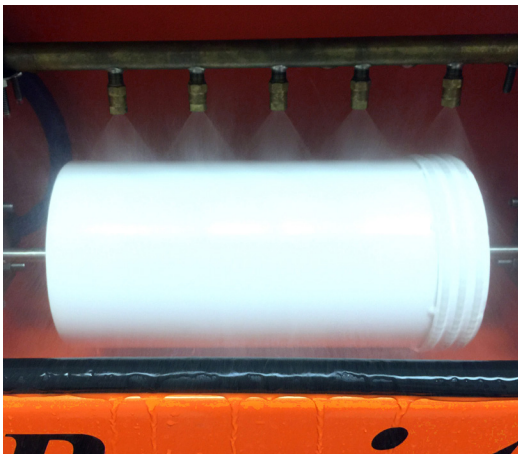

2. Close lid and turn water valve to “OPEN” position (vertical)

**Note:** As long as the lid is closed water should be contained within the 1020 Washout System or drain tray.

3. We recommend using a countdown timer for wash cycles (timer not included). Washout times may vary depending on water temperature, water pressure, and density of film.

### Recommended wash cycles:

- 3 MIL - 50 to 60 sec.
- 4 MIL - 70 to 80 sec.
- 5 MIL - 90 to 120 sec.

4. Turn OFF water valve to stop water flow by turning the valve to the “CLOSED” position (horizontal)
5. Examine the photomask film to ensure that the blue residue is completely removed from the artwork area.

**Optional:** Instead of running through another cycle to remove any blue residue you can use the auxiliary hand sprayer to touch-up on stubborn areas.

6. Open lid and pull the magnets away from photomask film. Remove washed sheet and let dry.

For Drying the photomask:

- Dry the photomask film for 20 - 40 minutes at room temperature; photomask should be uniform in color. High humidity will extend the drying time.
- Photomask(s) can be laid flat (carrier/glossy side down), or hung to dry.
- Photomask(s) can also be placed in a film dryer to significantly reduce drying times. Film dryer is optional.

# Maintenance

## Daily:

- Open the water valve for a clean rinse cycle after a production run. This will keep any residue from drying on the 1020 Washout System that could build up.
- Use dish soap with a soft sponge to wash drum and drainage tray.

## Monthly:

- Clean nozzles with a plastic bristle brush monthly.
- Remove and clean the washing nozzles using hard water deposit cleaner and plastic bristle brush monthly.

**Note:** When servicing the washout nozzles, or freeing a clogged nozzle, remove the nozzle and blow or rinse debris free, do not push anything through the opening, this could result in damage to the spray pattern.

Wash Nozzles are precision instruments and should be replaced annually as the high pressure will distort nozzle's opening, which will result in poor spray efficiency and increase overall GPM (Gallons per Minute). Do not let magnets be immersed in water for long periods of time (i.e. overnight). Magnet length should remain the width of the photomask.

Do not leave magnets on drum after washout cycle.

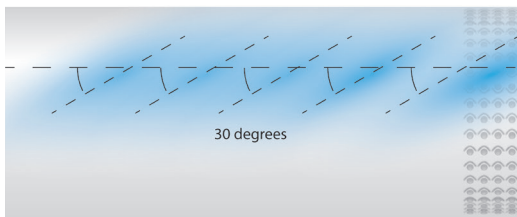

Washout Manifold/Spray Pattern: 30° off centerline



Proper magnet placement: 1/4" onto Photomask

# Tech Support

## The washout is inconsistent on several parts of the media.

Wash nozzles should not be lined up straight, but positioned approximately 30 degrees offset from center point of the wash manifold with the exclusion of the turbine nozzle.

## The magnets are falling off the drum during the wash cycle.

Confirm magnets are placed on the smooth side against the drum. The side with the horizontal line will face up. Also secure 1/4" of the edge of photoresist film sheet with the magnet.

## The drum is spinning too fast.

If the drum is spinning too fast then adjust the turbine nozzle (1/2" wrench) to a perpendicular position on the drum. Adjusting the turbine nozzle will slow the speed of the drum.

**The drum is not spinning and the water valve is in “ON” position.**

- Check the water supply hose connection to the washout manifold. Confirm the hose is connected and hose clamp is tight.
- If the drum is not spinning, this a sign that there is not sufficient water pressure to spin the drum. Spin the drum by hand and turn on water valve. The drum may need a manual start to spin.
- If the drum will not spin in a consistent rotation then adjust the turbine nozzle (1/2” wrench) to a parallel position to the drum.
- If the drum still does not spin, check the incoming water pressure and confirm pressure is set at least 40 psi.

# Replacement Parts



Drum



Magnet



Bearing



Wash Nozzle



955 Park Center Drive  
Vista, CA 92081-8312  
Toll Free: 800-729-9478  
Direct Phone: 760-727-8185  
Fax: 760-727-2986