

# **WEGA CONCEPT**







DICHIARAZIONE DI CONFORMITÀ CE - DECLARACIÓN DE CONFORMIDAD CE  
DECLARATION DE CONFORMITE CE - EC DECLARATION OF CONFORMITY  
EG-KONFORMITÄTSEKLRÄRUNG - EG VERKLARING VAN OVEREENSTEMMING  
DECLARAÇÃO DE CONFORMIDADE CE - DECLARATIE DE CONFORMITATE CE



WEGA s.r.l. Via Condotti Bardini, 1  
31058 SUSEGANA (TV) - ITALY

come costruttore di MACCHINE PER CAFFÈ, dichiara che il prodotto  
como fabricante de CAFETERAS, declara que el producto  
en tant que constructeur de MACHINES A CAFE, déclare que le produit  
being the manufacturer of COFFEE MACHINES, hereby declares that the product  
erklärt als Hersteller von KAFFEEMASCHINEN, daß das Gerät  
verklaart als fabrikant van KOFFIEZETAPPARATEN, dat het product  
como fabricante de MÁQUINAS DE CAFÉ, declara que a máquina  
in calitate de producator de APARATE PENTRU PREPARAT CAFEA, declara ca produsul

Tipo - Type - Typ - Tip

**Macchina per caffè - Cafeteras - Machines a cafe - Coffee machines  
Kaffeemaschinen - Koffiezetapparaat - Máquina de café - Aparat de preparat cafea**

Modello - Model - Modell - Modelo

N° di serie - Matricula  
N° de serie - Serial No  
Seriennummer - Seriennummer  
N° de série - Numar de fabrica

al quale si riferisce questa dichiarazione è conforme ai requisiti previsti dalle seguenti DIRETTIVE CEE:  
al que se refiere esta declaración es conforme con lo que disponen las siguientes DIRECTIVAS CEE :  
auquel se réfère cette déclaration est conforme aux exigences essentielles de DIRECTIVES CEE :  
to which this declaration refers, complies with the requirements set forth by the following EEC DIRECTIVES :  
auf welches sich diese Erklärung bezieht, gemäß den folgenden EG-Vorschriften gebaut ist EG-VORSCHRIFTEN :  
waar deze verklaring betrekking op heeft, overeenstemt met de vereisten van de volgende EG RICHTLIJNEN :  
referida nesta declaração, é conforme aos requisitos previstos pelas seguintes DIRECTIVAS CEE :  
la care se refera aceasta declaratie, este conform cu prevederile DIRECTIVELOR CEE :

**2006/42/CE - 2002/95/EC - 2002/96/EC - 2003/108/CE - 2004/108/CE - 2006/95/CE**

*in conformità alle norme - en conformidad de las normas - en conformité avec les normes - in compliance with standards  
gemäß den Vorsch - in overeenstemming met de normen - em conformidade com as normas - in conformitate cu normele :*

**EN 60335-1, EN 60335-2-75, EN 55014-1, EN 55014-2, EN 61000-3-2, EN 61000-3-3**

e DIRETTIVA - y NORMA CEE - et DIRECTIVE CEE - and EEC DIRECTIVE  
und EG-VORSCHRIFT - en de EEG RICHTLIJN - e DIRECTIVA CEE - si DIRECTIVA CEE:

**2009/142 CE**

*applicabile solo per i modelli con gas - aplicable solamente a los modelos con gas.  
applicable seulement aux modèles avec gaz - applicable for models with gas kit only  
nur fuer die Ausfuehrungen mit Gas erforderlich - die alleen bij modellen met gas van toepassing is  
aplicável somente para os modelos com gás - aplicabila numai in cazul modelelor cu gaz*

L'incarico di costituire e conservare il fascicolo tecnico è affidato al Responsabile Tecnico.  
La responsabilidad de elaborar y conservar el expediente técnico corresponde al Responsable Técnico.  
La tâche de constituer et de conserver le dossier technique est confiée à la Responsable Technique.  
The Technical Manager is responsible for establishing and maintaining the technical file.  
Es obliegt der technischer Leiter die technischen Unterlagen zu erstellen und aufzubewahren.  
Het technische dossier samenstellen en bewaren is taak van de Technical Manager.  
A responsabilidade de criar e guardar o fascículo técnico é confiada à Gerente Técnico.  
Sarcina constituirii si pastrarii dosarului tehnic este incredintata Responsabilului Tehnic.

Data di emissione - Fecha de emisión  
Date d'émission - Date of Issue  
Ausstellungsdatum - Datum van uitgave  
Data de emissão - Data emiterii

Susegana, 10/01/2011

Il Direttore Generale  
Dott. Paolo Nadalet

English

# Summary

1	Instructions.....	6	11	Autosteamer (*).....	16
1.1	Read carefully.....	6	11.1	Automatic heating and foaming.....	17
1.2	How to use this manual.....	6	11.2	Automatic heating.....	17
1.3	General warnings.....	6	11.3	Manual heating and foaming.....	17
1.4	Guarantee.....	7	11.4	Automatic cleaning.....	17
1.5	Typographical conventions.....	7	12	Energy Saving System.....	18
2	Presentation.....	8	13	Data reading and programming.....	19
3	Technical data.....	8	13.1	Main menu.....	19
4	Description of the machine.....	9	13.2	Counters.....	19
4.1	Description.....	9	13.3	Services boiler pressure adjustment.....	20
4.2	Push-button panel for coffee selections.....	10	13.4	Cup heater temperature adjustment.....	21
4.3	Display and browser key.....	10	13.5	Date and time adjustment.....	21
4.4	Push-button panel for services.....	10	14	Accessories.....	22
5	Warnings for the installer.....	10	14.1	Softener.....	22
5.1	Power supply.....	10	14.2	Cappuccino maker.....	23
5.2	Materials to be used.....	10	15	Group washing.....	24
5.3	Hydraulic connections.....	10	16	Checks and cleaning.....	25
5.4	Installation report.....	10	16.1	Checks and maintenance.....	25
5.5	Maintenance and repairs.....	11	16.2	Cleaning.....	25
6	Preparation.....	11	17	Suggestions on how to obtain a good cup of coffee..	26
6.1	Preparation of the machine.....	11	18	List of hazards.....	27
6.2	Grinding and dosing coffee.....	11	19	Display indications.....	28
7	Turning the machine on and off.....	12			
7.1	Turning the machine on.....	12			
7.2	Turning the machine off.....	12			
8	Preliminary operations.....	13			
8.1	Changing the water.....	13			
8.2	Cup heater.....	13			
8.3	Dispensing light and illuminated sides.....	13			
8.4	Cup raising grilles.....	13			
9	Programming doses.....	14			
9.1	Programming coffee doses.....	14			
9.2	Programming hot water doses.....	14			
10	Preparation of beverages.....	15			
10.1	Preparation of coffee.....	15			
10.2	Dispensing hot water.....	15			
10.3	Dispensing steam.....	15			

# 1 Instructions

## 1.1 Read carefully

Carefully read every part of this booklet before using the appliance.

The espresso coffee machine that you have purchased has been designed and manufactured with innovative methods and technologies which ensure long lasting quality and reliability.

This booklet will guide you in discovering the advantages of purchasing our product. You will find information on how to get the best out of your machine, how to always keep it efficient and what to do if you should have any problems.

Keep this booklet in a safe place. If you lose it, you can ask the manufacturer for another copy.

We take this opportunity to send you our best regards.

**ENJOY YOUR READING... AND YOUR COFFEE**

## 1.2 How to use this manual

The manufacturer reserves the right to make any improvements and/or modifications to the product. We guarantee that this booklet reflects the technical state of the appliance at the time it is marketed.

We take this opportunity to invite customers to make any proposals for improvement of the product or the manual.

## 1.3 General warnings

- After removing the packaging, check the condition of the appliance. If in doubt, do not use it but contact the retailer directly.
- The packaging material must not be left within the reach of children since it is a potential source of danger. It is advisable to keep the packaging until after the guarantee has expired.
- Before using the machine, make sure that the mains voltage corresponds to the information on the data plate of the machine.
- Installation must be done in accordance with the safety standards in force and by qualified and prepared personnel. Incorrect installation may be harmful to people, property or animals.
- This appliance is completely safe only if it is connected to an effective grounding system, executed as required by current safety standards. The electric system must be equipped with a suitable differential circuit breaker. It is important to have compliance with these requirements checked. If in doubt, have the system carefully checked by qualified personnel. The manufacturer cannot be considered responsible for any damage caused by an inadequate electric system.
- Upon installation of the machine, qualified personnel will be required to install a main switch as required by current safety regulations, with a distance of contact aperture greater than or equal to 3 mm.
- It is not advisable to use extensions or electrical adaptors with multiple outlets. If their use is indispensable, use only simple or multiple plug adaptors and extensions which are in accordance with the safety standards in force. Never exceed the power value in kW indicated on the simple adaptor and on the extensions and the maximum power value indicated on the adaptor.
- This appliance is to be used only for what it has been designed for. Any other use is considered improper and therefore dangerous. The manufacturer cannot be held responsible for any damage caused by an incorrect and unreasonable use.
- When using the electrical appliance several safety behavioural standards must be observed:
  - do not touch the appliance when hands or feet are wet or damp;
  - do not use the appliance in bare feet;
  - do not use extensions in rooms where there are showers or baths;
  - do not pull on the power cord to unplug the appliance;
  - do not leave the appliance exposed to atmospheric agents (rain, sun, etc.)
  - do not allow the appliance to be used by children or incapable people.
- Make sure that the machine is used in a room that is sufficiently lit, aerated, and hygienic.

- The spaces accessing the machine and the main switch must be left clear, in order to allow the user to intervene without any constriction and to be able to leave the area immediately in the case of necessity.
- Do not spray water on the machine to clean it. Clean daily following the instructions given in this manual.
- In case of breakdowns or poor functioning turn off the appliance and do not attempt any repairs.
- Any repairs must be done only by the manufacturer or an authorised service centre using original spare parts only. If this standard is not observed the safety of the appliance is compromised and cancels the guarantee.
- The power supply cable must not be replaced by the user. If the cord is damaged, turn the machine off and contact professionally qualified personnel only.
- If you should decide not to use the appliance any longer, it is recommended to make it inoperative by disconnecting the power supply cable from the electrical network and emptying the water.
- To guarantee that the machine is efficient and works properly it is essential to follow the manufacturer's instructions, having periodical maintenance and a check of all the safety devices done by qualified personnel.
- Do not expose your hands or other body parts to the coffee, steam, or hot water spouts. The steam and water that come from the spouts can cause burns.
- When functioning, the steam and water spouts become overheated and are to be handled with caution only in the indicated parts.
- Cups must be placed on the top only after having been thoroughly dried. Do not use this top for items that do not appertain to the coffee maker
- The appliance must not be used by people (including children) with reduced physical, sensorial or mental capacities or by people without experience or knowledge, unless they can be supervised by or receive instructions regarding appliance use from a person who is responsible for their safety.
- Children must be supervised, to make sure they do not play with the appliance.
- The coffee machine must be used at a temperature between 5°C and 40°C.
- Any unauthorised tampering with any parts of the machine renders any guarantee null and void.

## 1.4 Guarantee

12 months on all components except electrical and electronic components and expendable pieces.

## 1.5 Typographical conventions



**This symbol indicates that you must strictly follow the instructions to which it refers in order to avoid severe injury and/or damage to the machine.**



**This symbol provides additional information on the operation of the machine and its components.**

## 2 Presentation

This product has been manufactured in compliance with the regulations for foodstuff machinery according to par. 2.1 of Directive 2006/42/EC.

The espresso coffee machine is strictly for professional use only. It is designed for the preparation of hot drinks such as tea, cappuccinos and long, short and espresso coffee, etc.

This device belongs to the family "Green Line", that is a range of products with low environmental impact, able to reduce consumption.

The instructions for a proper use of the machine are provided below.



**The user must be sufficiently informed to operate the machine correctly. It is recommended not to carry out any operations on the machine which may modify or alter its operation. WHEN THE MACHINE IS IN OPERATION, THE BOILER CONTAINS STEAM AND HOT WATER UNDER PRESSURE.**

## 3 Technical data

The technical data indicated in the table below corresponds to the data plate located on the front of the machine.

The data of the appliance can be seen also on the label located on the package of the machine.

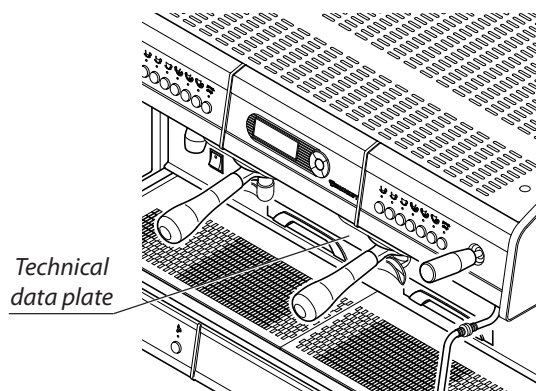

		2Gr		3Gr		4Gr	
Power supply voltage	V	230/400	240/415	230/400	240/415	230/400	240/415
Total power	W	4.400	4.790	5.600	6.100	7.100	7.730
Power x group	W	150x2	165x2	150x3	165x3	150x4	165x4
Coffee water tank heating element power per group	W	1,000x2	1,090x2	1,000x3	1,090x3	1,000x4	1,090x4
Steam boiler power	W	3.000	3.270	3.000	3.270	5.000	5.445
Steam boiler capacity	lt / UK gal	8 / 1,76		13 / 2.86		13 / 2.86	
Coffee water tank capacity	lt / UK gal	(1.2/ 0.26)x2		(1.2/ 0.26)x3		(1.2/ 0.26)x4	
Width	mm / in	800 / 31.5		1040 / 40.9		1280 / 50.4	
Depth	mm / in	580 / 22.8		580 / 22.8		580 / 22.8	
Height	mm / in	590 / 23.2		590 / 23.2		590 / 23.2	
Net weight	kg / lb	95 / 209		117 / 257		142 / 312	
Operating conditions	°C / °F	5 ÷ 40 / 41 ÷ 104					

Technical data table



## 4 Description of the machine

### 4.1 Description

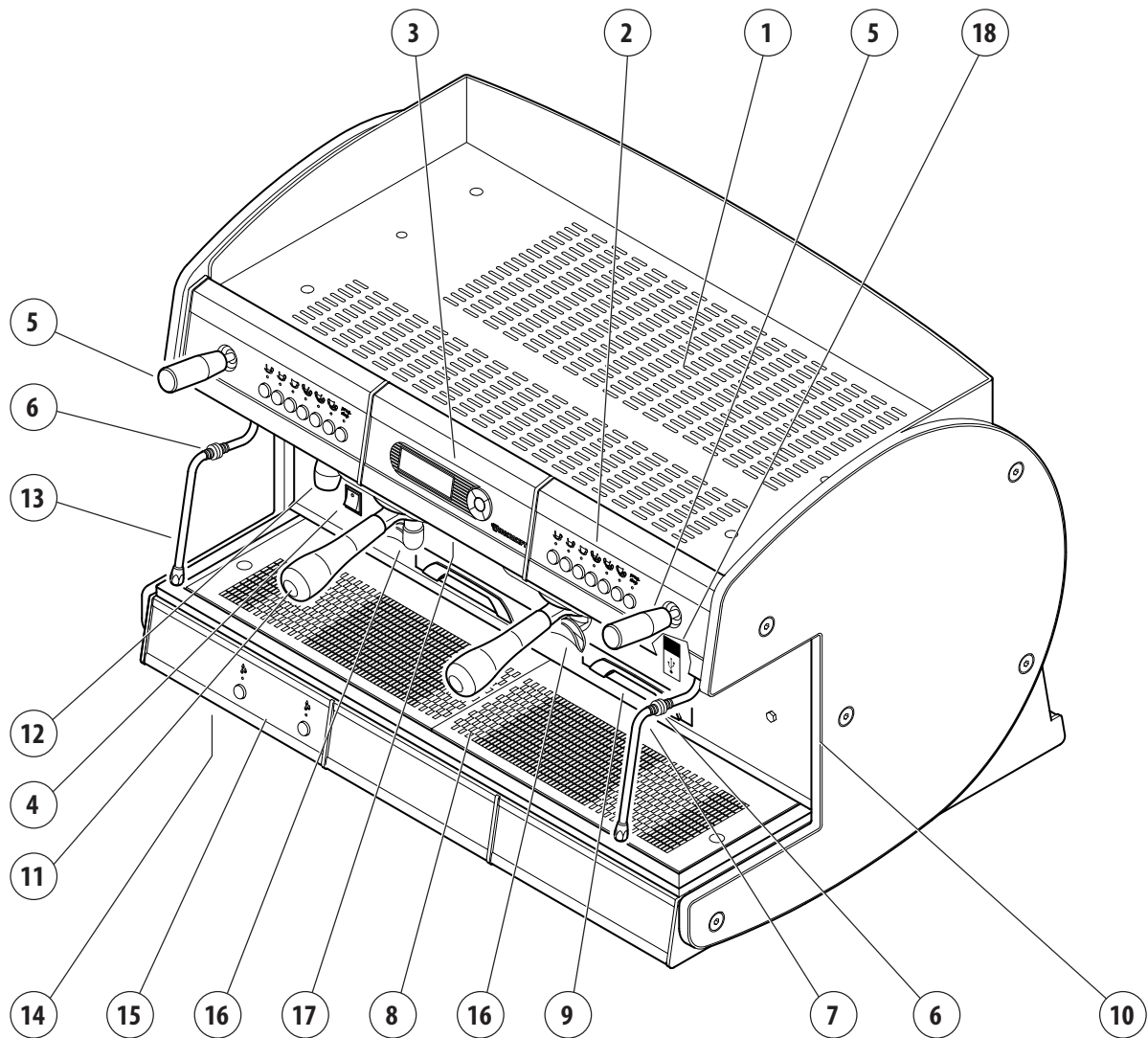

- |   |  |
|---|--|
| 1. Cup heater surface.                      | 10. Illuminated side.                                |
| 2. Push-button panel for coffee selections. | 11. Portafilter.                                     |
| 3. Display and browser key.                 | 12. Hot water delivery nozzle.                       |
| 4. Machine power switch.                    | 13. Steam delivery nozzle/autosteamer (*).           |
| 5. Steam knob.                              | 14. Adjustable foot.                                 |
| 6. Anti-burn rubber.                        | 15. Push-button panel for services/ autosteamer (*). |
| 7. Steam nozzle.                            | 16. Dispensing spouts.                               |
| 8. Tray and cup support grille.             | 17. Dispensing compartment light.                    |
| 9. Pull-out cup support grille.             | 18. USB socket (for technical service only)          |

(\* optional.

## 4.2 Push-button panel for coffee selections

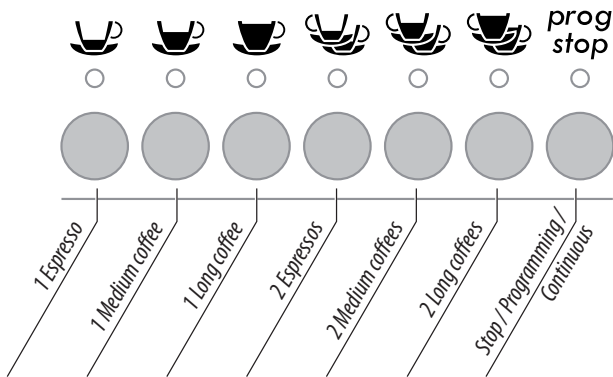

## 4.3 Display and browser key

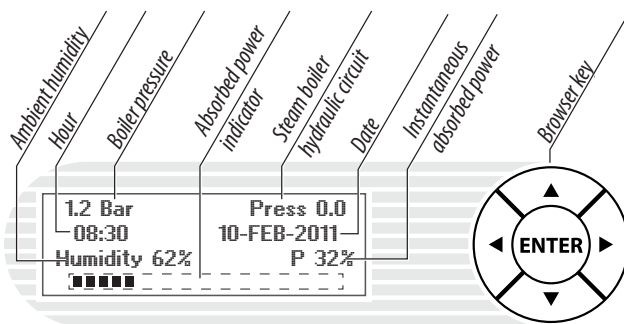

## 4.4 Push-button panel for services

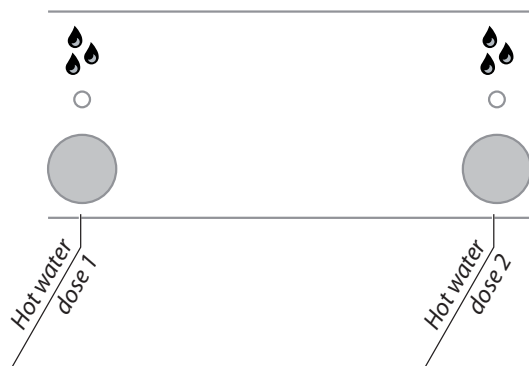

# 5 Warnings for the installer

## 5.1 Power supply

The water supply of the appliance must be carried out with water which is suitable for human consumption, in compliance with the regulations in force in the place of installation. The owner / manager of the system must confirm to the installer that the water meets the above listed requirements.

## 5.2 Materials to be used

During the installation of the appliance the components and materials that were provided with the appliance are to be used. Should the use of other components be necessary, the installer must verify their suitability to be used in contact with water used for human consumption.

## 5.3 Hydraulic connections

The installer must carry out the hydraulic connections in accordance with the hygiene norms and the hydraulic safety norms for environmental protection in force in the place of installation.

## 5.4 Installation report

When installation is complete, the appliance has to be started, brought to the nominal working condition and left for 30 minutes in the "ready to operate" condition.

Afterwards, the appliance has to be turned off and emptied of the first water introduced in the whole hydraulic circuit, to eliminate possible initial impurities.

Then the appliance must be once again loaded and brought to the nominal working conditions.

After having reached the "ready to operate" condition, the following deliveries have to be performed:

1. for each coffee unit, carry out a continuous delivery, in order to release the whole volume of water contained in each associated coffee tank (1.2 liters);

2. release the whole volume of hot water inside the boiler (8 liters for 2GR, 13 liters for 3GR and 4GR), by performing a continuous delivery from the appropriate nozzle. In the case of several dispensing points, divide the volume on the base of the number of the dispensing points;
3. continuously release steam for at least 1 minute for each steam dispensing point;

When installation is complete, the installer must write a report about the performed operations.

## 5.5 Maintenance and repairs

After a maintenance and/or repair intervention, the components used must ensure that the hygiene and safety requirements initially foreseen for the appliance are still met. These are met by using original spare parts only.

After a repair or a substitution of components related to parts in direct contact with water and food, a washing procedure has to be carried out, as in the case of first installation.

## 6 Preparation

### 6.1 Preparation of the machine

The preparation of the machine and the installation operations must be carried out by qualified personnel only.

The installer must strictly follow the indications provided in chap. 5 "Warnings for the Installer".



**Using the machine without all the installation operations having been carried out by technical personnel could damage it seriously.**

### 6.2 Grinding and dosing coffee

Place the grinder-doser in a convenient place near the machine.

Grinding and dosing of coffee must take place in accordance with the instructions of the manufacturer of the grinder-doser.

To obtain good quality espresso coffee we suggest the following:

- not to store large amounts of coffee beans. to observe (in any case) the expiry date indicated by the producer.
- to grind an amount of coffee based on use, prepare the amount contained in the doser and if possible use it before the end of the day;
- never to buy (if possible) already ground coffee, as it expires quickly. if necessary, to buy it in small vacuum-sealed packages.

to fill the filter with a dose of ground coffee (about 6-7 gr.) and press it with the special coffee presser. Hook the portafilter to the delivery group.



**To prevent the seal from wearing too soon, clean the edge of the filter before engaging the portafilter on the delivery group. Do not excessively tighten the portafilter to the dispensing group.**

# 7 Turning the machine on and off

## 7.1 Turning the machine on

After the hydraulic and electrical connection has been performed by the qualified personnel, verify that all the steam taps are closed.

Turn the machine on using the main switch (4) and follow the indications provided on the machine's display, as described below.

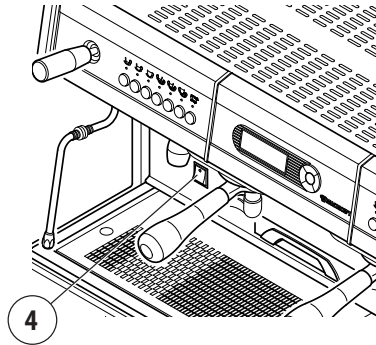

When the machine is turned on, it performs the functional test and reports information regarding the software installed.

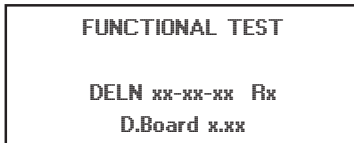

- xx-xx-xx : update date
- Rx : software revision number;
- D.Board x.xx: display card version.

The result O.K. indicates that the machine is working correctly.

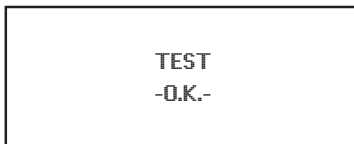

If the machine fails the functional test, contact the Technical Support Service.

When the machine is turned on, it will activate the motor pump installed and begin to fill the services boiler and the water heaters for the coffee (present in a number equal to the number of delivery groups installed on the machine.)

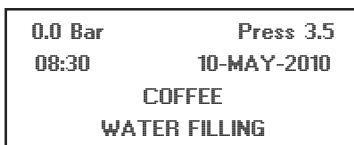

In order to bleed any air present in the heaters, each time the machine is turned on the solenoid valves of the groups will be activated, making water and steam come out from the perforated disk of each group for about 10 seconds.

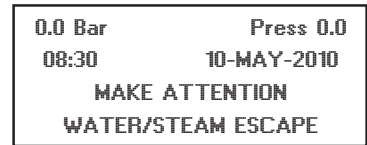

When the heating phase of the delivery groups has finished (after about 10 minutes), signalled by the disappearance of the "PLEASE WAIT" indication, it will be possible to make the coffee selections. For the dispensing of hot water and steam, it will be necessary to wait for the complete heating of the services boiler.

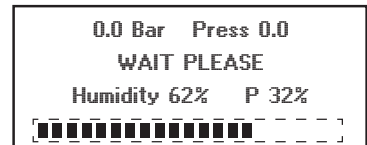

During the heating phase of the services boiler (from 95°C to 98°C), the machine will execute a light delivery of water and steam from the hot water nozzle.

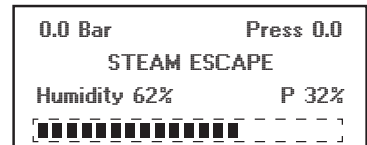

The dispensing of steam and hot water, and thus the full operation of the machine, will be possible only at a pressure greater than 0.6 bar.

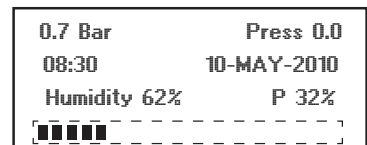

**To avoid the risk of burns, it is advisable to keep hands away from the hot water nozzle, steam nozzle and delivery groups during the machine's heating phase.**

## 7.2 Turning the machine off

To turn the machine off, just use the main switch (4).

## 8 Preliminary operations

### 8.1 Changing the water

In case of breaks longer than 1 week, it is necessary to perform the changing of the 100% of the water contained in the hydraulic circuits of the machine, by using the appropriate dispensing points, as described in the Paragraph 5.4 "Installation report".

### 8.2 Cup heater

Place the cups to be heated on the appropriate surface (1).

To turn on the cup heater, press the (▲) navigator key; an asterisk will appear on the first line of the display to the far right of the display, indicating that the cup heater is ON.

To turn it off, press the (▲) navigator key again, the asterisk will disappear.

To change the temperature of the cup heater, proceed as described in chapter 13.4.

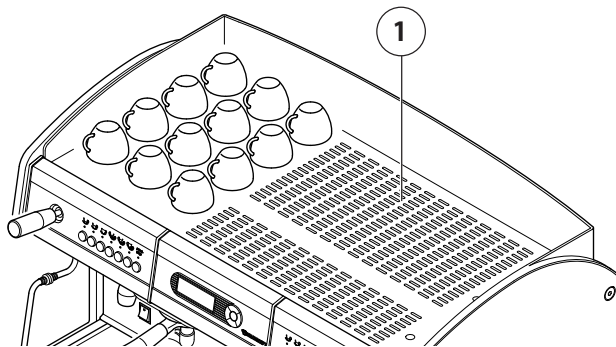
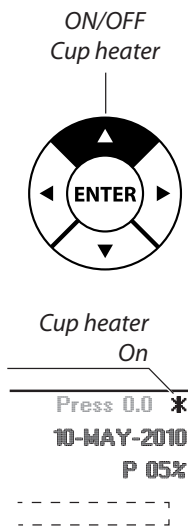

**For safety reasons, it is advisable not to place cloths or other objects on the cup heater surface (1).**



**If the cup heater is set to a temperature lower than 70 °C in the adjustment menu, it will remain off, even if switched to ON (\* symbol on the display).**

### 8.3 Dispensing light and illuminated sides

To activate and deactivate the illumination of the dispensing compartments and of the sides of the machine, press the (▼) key of the browser repeatedly.

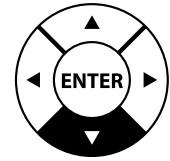

The lights will switch on sequentially, depending on the number of presses performed on the key.

The table below, shows the correspondence between the number of presses and the switching on of the lights.

n° of presses on the key (▼)	Dispensing compartment light	Sides light
1	ON	OFF
2	ON	ON
3	OFF	ON
4	OFF	OFF

### 8.4 Cup raising grilles

When using cups of different heights, you can use the special concealed grilles (9) which the machine is equipped with.

To use the pull-out grille, extract it from its seat by pulling it outwards until it is fully blocked in position.

When finished using the grille, push it towards the machine until it disappears completely into its seat.

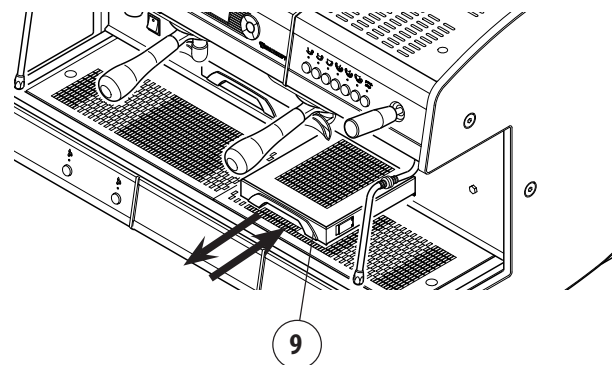

## 9 Programming doses

### 9.1 Programming coffee doses

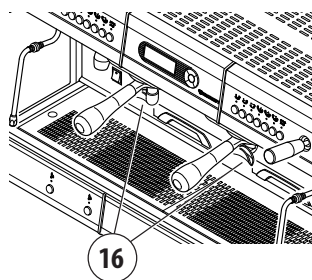

To program the dose keys, proceed as follows:

- press and hold the "**PROG/STOP**" key down for 5 seconds: the LED of the "**PROG/STOP**" key will flash and all keys on the push-button panel being programmed will turn on;
- fill the filter with a dose of ground coffee and press it with the coffee press;
- attach the portafilter to the delivery group;
- put the coffee cup under the dispensing spout (16);
- press the desired dose key (e.g.: "1 Espresso" );
- wait for delivery;
- to confirm the desired dose press again the dose key or the "**PROG/STOP**" key;
- once the dose is confirmed, the LED of the programmed key switches off and only the keys yet to be set remain on;
- repeat this operation for the other dose buttons;
- upon completion of programming, press the "**PROG/STOP**" key to exit dose programming.



### 9.2 Programming hot water doses

To program the hot water doses, proceed as follows:

- place the cup under the hot water nozzle (12);
- press and hold down the "**PROG/STOP**" key on the left push-button panel until all dose key LEDs switch on;
- press the hot water delivery key ;
- when the desired dose has been reached, confirm by pressing the hot water key  again;
- repeat the operation for the other dose button;
- upon completion of programming, press the "**PROG/STOP**" key.

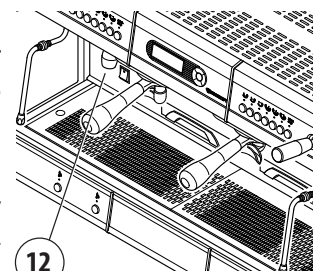

**i**

All models are provided with 2 keys for the dispensing of hot water. These can be programmed individually and supply doses which are independent from one another.

**i**

The 4GR version has 2 hot water nozzles. The left key controls the left hot water nozzle, while the right key controls the right hot water nozzle.

**i**

After 30 seconds of idle time, the machine will automatically exit the dose programming mode, confirming the already programmed ones.

**i**

The programming of each dose must be carried out with ground coffee and not with previously used coffee grounds.

**i**



It is possible to program all the push-button panels of the machine simultaneously using only the left push-button panel. To obtain different doses for the various groups, perform the programming by starting with the left push-button panel and then all the others.

## 10 Preparation of beverages

### 10.1 Preparation of coffee

- Fill the filter with a dose of ground coffee and press it with the coffee press;
- attach the portafilter to the delivery group;
- put the coffee cup under the dispensing spout (16);
- press the desired dose key (e.g. "1 Espresso" ) and wait for coffee delivery (all LEDs switch off, except for that of the selected key).
- to stop delivery of coffee in advance, press the delivery key again or press the "**PROG/STOP**" key.

### 10.2 Dispensing hot water

- Place the cup under the hot water nozzle (12);
- press the hot water key , wait for the delivery of water;
- to stop delivery in advance, press the hot water key again .



When the machine is cool (pressure below 0,6 bar) the dispensing of hot water is not active.



To change the temperature of the water delivered, contact the Technical Support Service.

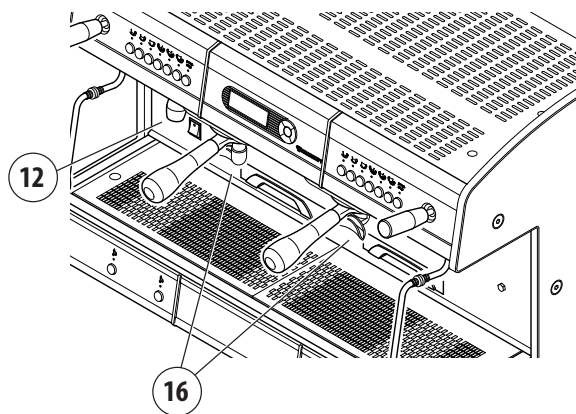

### 10.3 Dispensing steam

Immerse the steam nozzle into the liquid to be heated and operate the tap knob (5), by turning it horizontally: the steam coming out of the nozzle (7) will be proportional to the opening of the tap.

If the knob is released, it will return to the closed position, stopping the dispensing.

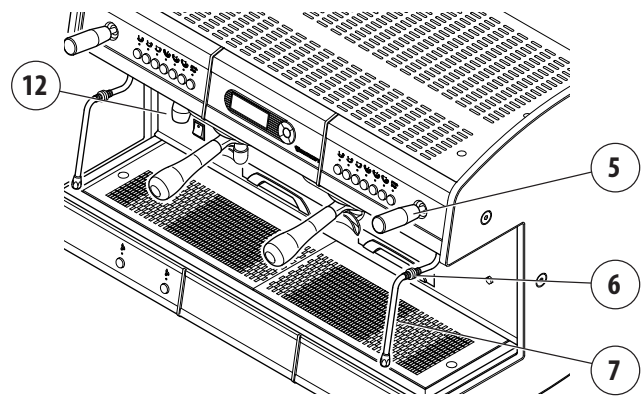

By moving the knob vertically, it is possible to hook it in the constant opening position, in order to have a continuous dispensing of steam.

To stop the outflow of steam through the nozzle, manually return the knob to the OFF state, disengaging it from the opening position.

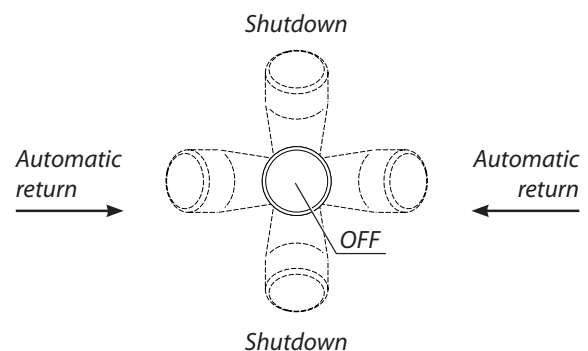

To obtain an optimal foaming, it is recommended to observe the following simple rules:

- heat only the amount of milk you intend to use, once heated, it will have to be completely poured from the jug and mustn't be heated again;
- the milk to be foamed must have a starting temperature of 4°C;

**LEAVE THE STEAM NOZZLE IMMERGED IN THE MILK ONLY FOR THE TIME REQUIRED FOR HEATING. DO NOT OPEN THE STEAM TAP WITH THE STEAM NOZZLE IMMERGED IN MILK WHILE THE MACHINE IS OFF.**

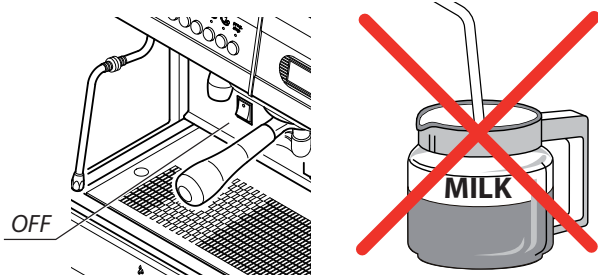

**Carefully move the steam nozzle using the anti-burn rubber bulb (6) and never touch the steam nozzle (7) or the hot water nozzle (12): contact with the hot water or steam may be harmful to individuals, animals or property.**

**The use of the steam dispensing point (steam nozzle), must always be preceded by the performance of the condensation draining operation for at least 2 seconds.**

**To keep the steam nozzle tips in perfect working order, it is advisable to carry out a brief delivery dry run after each use. Keep the tips clean at all times using a cloth dampened in lukewarm water. Handle the nozzle with utmost caution due to the hazard resulting from the presence of high-temperature steam.**

## 11 Autosteamer (\*)

The "Autosteamer" system can be used for automatically heating and foaming milk to the programmed temperature.

It can be controlled using the keypad (15) located on the left base of the machine.

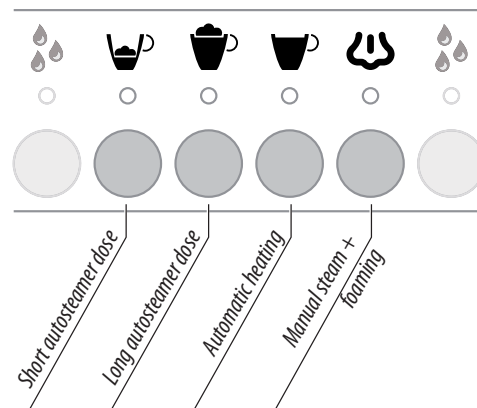
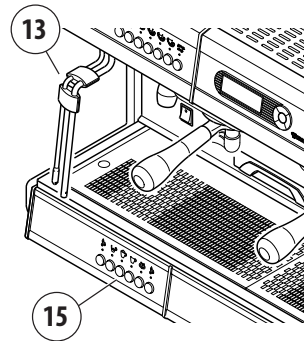

To obtain an optimal foaming, it is recommended to observe the following simple rules:



- heat only the amount of milk you intend to use, once heated, the milk will have to be completely poured from the jug and mustn't be heated again;
- the autosteamer guarantees a correspondence of  $\pm 3^{\circ}\text{C}$  between the set temperature and the real temperature of the milk, only by starting from a milk temperature of  $4^{\circ}\text{C}$ ;
- since the dispensing of steam stops on its own when the set temperature of milk is reached, to prevent the milk foam spilling out, it is necessary to introduce a volume of liquid not higher than 1/2 of the capacity of the jug.
- use a container with a capacity of 0.75 liters and fill it to the half with milk;
- set a maximum heating temperature of  $60^{\circ}\text{C}$  (contact the technical service).

(\*) optional.



## 11.1 Automatic heating and foaming

Proceed as follows:

- Immerge the tips of the autosteamer (13) into the beverage;
- press the  or  key, depending on the dose of milk in the jug;
- wait until the dispensing is finished;
- when the dispensing has finished, the milk will be foamed and heated to the preset temperature.
- To stop dispensing ahead of time, press the same key;
- to prolong the dispensing of steam, use the key "Manual steam" .

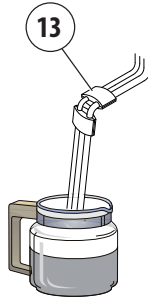

To increase or decrease the consistency of the foam, slightly adjust the special regulator (A). Turning it clockwise will decrease the consistency, while turning it counterclockwise will increase it.

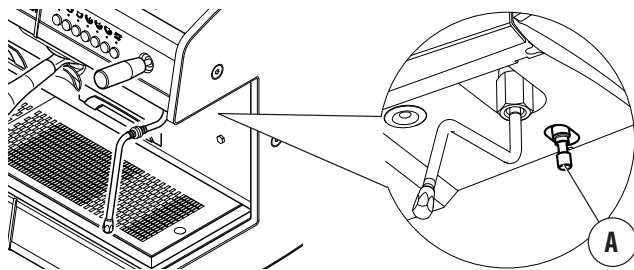

Always proceed by performing slight adjustments.



**The autosteamer foaming is factory-adjusted, in the testing phase of the machine. Therefore, it is recommended to modify the adjustment only if strictly necessary.**

## 11.2 Automatic heating

Proceed as follows:

- Immerge the tips of the autosteamer (13) into the beverage;
- press the  key;
- wait until the dispensing is finished;
- once the dispensing has finished, the milk will be heated to the programmed temperature, but not foamed.
- To stop dispensing in advance, press the same key;
- to prolong the dispensing of steam, use the key "Manual steam" .

## 11.3 Manual heating and foaming

This control allows the user to use the autosteamer nozzle to heat and at the same time foam the milk, letting him use it manually.

Proceed as follows:

- Immerge the tips of the autosteamer (13) into the beverage;
- press the  key;
- To stop dispensing, press the same key again.

## 11.4 Automatic cleaning

After 120 minutes of idle time the automatic cleaning of the nozzle starts, lasting 15 seconds.

The message will appear on the display: "STEAM CLEANING CYCLE"

A minimum amount of steam will exit the nozzle.



The use of the steam dispensing point (autosteamer nozzle), must always be preceded by the performance of the condensation draining operation for at least 2 seconds.



The system includes a time limit of a maximum of 4 minutes for autosteamer operation.



To change the temperature of the autosteamer, and to enable or disable its operation, contact the Technical Support Service.



To keep the steam dispensers in perfect working order, it is advisable to carry out a brief delivery dry run after each use. Keep the tips of the autosteamer clean at all times using a cloth dampened in lukewarm water. If regular cleaning is not carried out, the proper operation of the autosteamer can be compromised.



Do not leave the autosteamer nozzle immersed in the milk when it is not being used. Handle the autosteamer with utmost caution due to the hazard resulting from the presence of high-temperature steam.

## 12 Energy Saving System

The machine is provided with a software that manages the automatic standby system during breaks, the night Energy-saving feature and the intelligent adjustment of the temperature.

This allows a considerable energy saving, during night breaks, maintaining the machine in the condition to quickly return to operate.

Moreover, the software distributes the power only where and when it is needed, thus allowing to save energy during the normal working activity too.

If provided for in the programming, it automatically puts into standby one or more groups when the workload decreases and prepares them for full capacity when needed.

All this is indicated in the following way:

### ENERGY SAVING

+ flashing of the "PROG/STOP" LEDs

Flashing "PROG/STOP" LED

All the groups are in standby, the entire machine (including the services boiler) is in energy saving phase.

One or more delivery groups (but not all of them) are in standby.

To bring a dispensing group back from standby, press and hold the respective "PROG/STOP" button for 3 seconds.

It will return to full operation in about 1-2 minutes.

If the machine is in the "ENERGY SAVING" mode, also the services boiler will be reactivated, thus exiting the "energy saving" mode.

The dispensing groups and the services boiler, which have been reactivated, will remain operative until the next time limit set for the start-up of the energy saving mode (for the machine) or of the standby mode (for the dispensing groups) expires.

The system will continue to follow the programmed energy saving settings.



To change the operating parameters of the "energy saving" system, contact the Technical Support Service.

# 13 Data reading and programming

## 13.1 Main menu

To access the reading of machine data and the programming of the main parameters, hold down the **ENTER** key of the navigator key for at least 5 seconds.

The following messages will appear on the display:

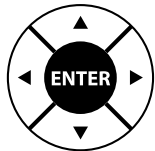

To select the item concerned, use the (▲) and (▼) keys.

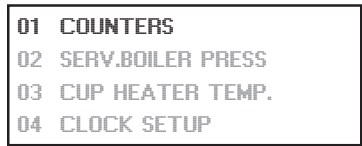
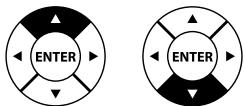

To exit the menu, press the (◀) or (▶) key.

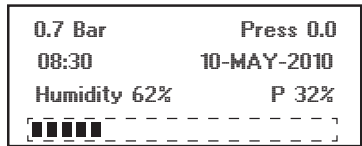
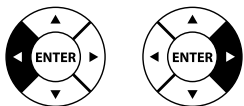

## 13.2 Counters

In this section it's possible to display the number of selections made (total and individual) as well as the number of doser alarms.

Scroll through the menu until the item **"01 COUNTERS"** is highlighted;

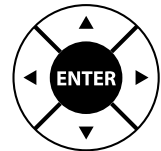

Confirm the selection by pressing the **ENTER** key and the display will show the following:

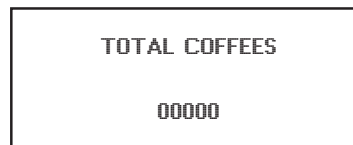

*Total number of selections made on the machine.*

To display the partial strokes for the various types of delivery, press the respective keys on the push-button panel.

The selected key will light up, and the count of selections made will appear on the display.

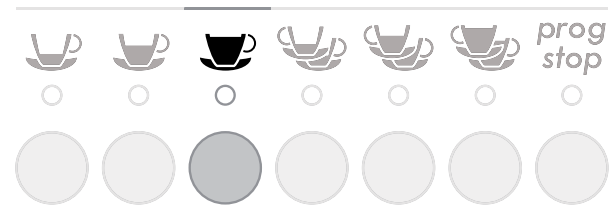

*Number of coffee/hot water selections made on the machine.*

## Doser alarms

Inside the "COUNTERS" menu, it's also possible to display the number of alarms that have occurred for the volumetric dosers.

When inside the menu, by pressing the (◀) or the (▶) key, it is possible to alternate the coffee/water selections count screens and the doser alarms.

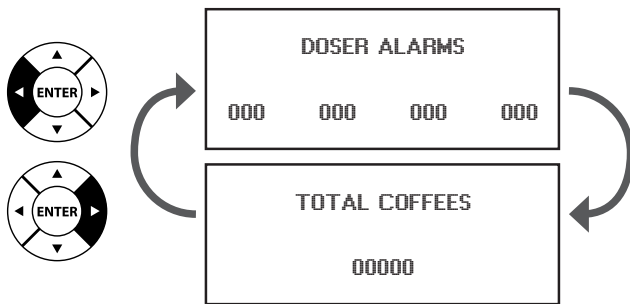

To exit the "COUNTERS" menu, press the **ENTER** key.

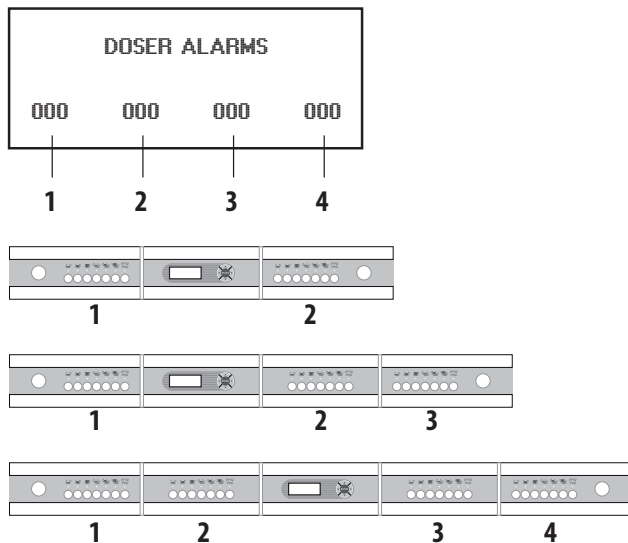
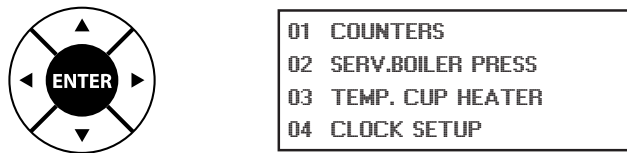

Correspondence diagram between the display alarm position and the machine group position

**i** In case of inactivity of the operator, after 10 seconds, the display will return to the main menu.

## 13.3 Services boiler pressure adjustment

In this section it is possible to modify the pressure of the services boiler (hot water / steam).

Scroll through the menu until the item "**02 BOILER PRESSURE**" is highlighted;



confirm the selection by pressing the **ENTER** key and the display will show the following:



The value of the pressure will flash.

To change the pressure (from 0 to 1.4 bar), press the (▲) key or (▼) key.

To confirm and exit from the adjustment mode, press the **ENTER** key.

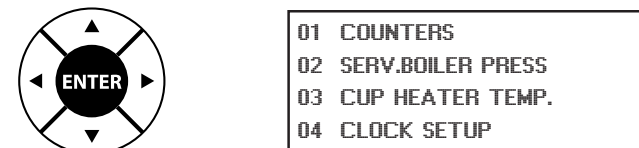

**i** The machine comes out of the factory with a pressure value of 1.2 Bar, which allows an optimal use of the services for a normal workload. It is possible to increase or decrease this value, depending on the weight of usage of the hot water and steam services.

The dispensing of coffee is not influenced by this parameter.

**i** If the machine is provided with an "auto-steamer" device, it is advisable to leave the pressure of the services boiler at 1.2 Bar (optimal value for the correct operation of the autosteamer).

### 13.4 Cup heater temperature adjustment

This menu allows the user to adjust the operating temperature of the cup heater or switch it off.

Scroll through the menu until the item **"3 CUP HEATER TEMP."** is highlighted;

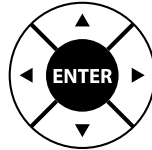
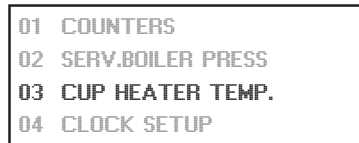

confirm the selection by pressing the **ENTER** key and the display will show the following:

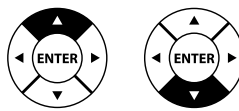
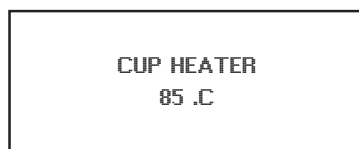

The value of the temperature will flash.

To change the temperature (from 70 to 114 °C), press the (▲) key or (▼) key.

To confirm and exit from the adjustment mode, press the **ENTER** key.

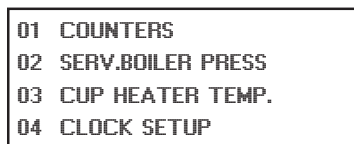
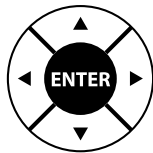

**i** If a temperature above 114°C is set, the indication **CUP HEATER ON** will appear on the display and the cup heater will be activated in continuous operation.

**i** If a temperature lower than 70°C is set, the indication **CUP HEATER ---** will appear on the display and the cup heater will be deactivated.

**i** To turn the cup heater on and off, read chapter 8.1.

### 13.5 Date and time adjustment

In this section it is possible to set the date and time shown on the machine's display.

Scroll through the menu until the item **"04 CLOCK SETUP"** is highlighted;

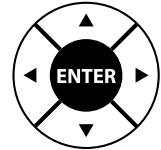

Confirm the selection by pressing the **ENTER** key and the display will show the following:

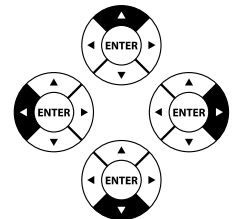
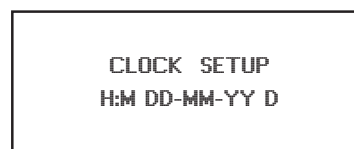

The value to be changed will flash.

To change the value, press the (▲) key or (▼) key.

To move to the next or previous parameter, press the (◀) key or (▶) key, and repeat the modification process.

To confirm and exit the menu, press the **ENTER** key.

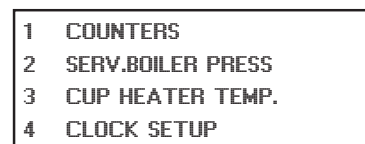
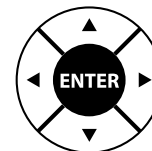

H	hours	
M	minutes	
DD	day	1 Monday
MN	month	2 Tuesday
YY	year	3 Wednesday
D	day of week	➔ 4 Thursday
		5 Friday
		6 Saturday
		7 Sunday

Legend

# 14 Accessories

## 14.1 Softener

Mains water contains insoluble salts, which cause the build-up of lime scale deposits in the boiler and in other parts of the machine. The softener makes it possible to eliminate or substantially reduce the presence of these mineral salts. The resin softener has the property of retaining the calcium contained in the water. For this reason, the resins become saturated after a certain period and must be regenerated with coarse kitchen salt (NaCl, sodium chloride) or special water softening salt. It is very important to regenerate the softener within the established times. The regeneration is to be done regularly every 15 days. However, in locations with very hard water, it will be necessary to regenerate more frequently. The same rule can be applied to places where there is a large consumption of hot water for tea or other uses.

### Softener regeneration

Proceed as follows:

- move levers **(B)** and **(E)** from left to right;
- remove the lid by loosening the knob **(A)**;
- release enough water through the pipe **(C)** to make room for the amount of salt to be introduced, as required depending on the model (see the table on the following page);
- clean any salt or resin residue from the gasket located on the lid;
- put the lid back in place by screwing the knob **(A)** down securely and move the lever **(B)** back from right to left;
- let the salt water drain from the small tube **(D)** until the water is no longer salty (about 30-60 minutes). The salt allows the accumulated mineral salts to be released;
- bring the lever **(E)** from right to left back to its initial position.

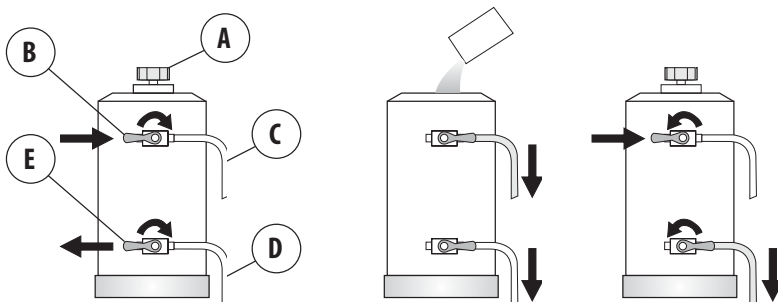

**The build-up of lime scale deposits in the hydraulic circuit and boiler inhibits thermal exchange, thus compromising proper operation of the machine. Heavy incrustations in the boiler may cause long machine shutdowns and in any case invalidate any guarantee, because this symptom indicates that regeneration has been neglected.**

In order to keep the softener and hence the machine in perfect operating condition, it is necessary to perform regeneration periodically based on the use of the softener and the hardness of the water that is used. The table below shows the quantity of softened water based on the hardness of the water in the various units of measure:

- F°: French degree
- D°: German degree = 1.8 °F
- mg CaCO<sub>3</sub>

For further information on installation, start-up and regeneration of the softener, refer to the relative instruction manual.

Amount of softened water based on hardness

F°	30	40	60	80	salt
D°	16,5	22	33	44	
mg CaCO <sub>3</sub>	30	40	60	80	
8 litres	1000 lt	900 lt	700 lt	500 lt	
12 litres	1500 lt	1350 lt	1050 lt	750 lt	1.5 kg
16 litres	2100 lt	1800 lt	1400 lt	1000 lt	2.0 kg

Softener model	Amount of salt
8 litres	1.0 kg
12 litres	1.5 kg
16 litres	2.0 kg

## Regeneration notification

If the function has been enabled during programming, the system measures the amount of water used by the machine and signals on the display (with the flashing phrase "WATER SOFTENER REGENERATION") the need for regeneration when the set amount has been exceeded.

Once the regeneration has been carried out, the counter must be reset.



To reset the litres count, contact specialised personnel.

## 14.2 Cappuccino maker

- Put the suction tube inside the milk;
- place the jug under the spout of the cappuccino maker;
- open the steam tap, when the desired amount is reached close the steam tap;
- pour the foamed milk into the cups with coffee.

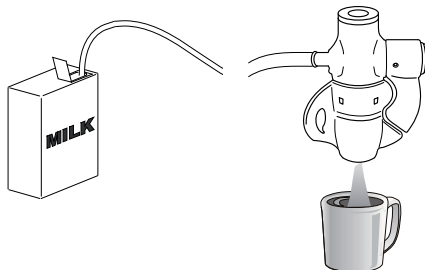

To obtain the dispensing of warm milk without foam, lift the tab (Z) upwards. For better results, we suggest not to dispense directly into the coffee cup, but into a jug or pot, and to then pour the foamed milk on the coffee. Be sure the cappuccino maker is kept clean as described in the chapter "Cleaning".

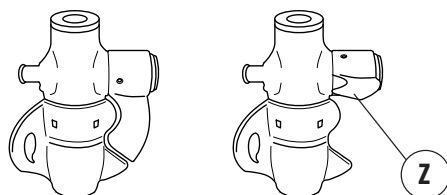

## Cleaning

Use special care in cleaning the cappuccino maker, following the procedures indicated below:

- perform a first washing by immersing the suction tube in water and run a delivery for a few seconds;
- turn the rotating body (X) 90° to position B (closure of milk outlet duct);
- holding the milk suction tube in the air, dispense steam (cappuccino maker dry run);
- wait about 20 seconds to allow for internal cleaning and sterilisation of the cappuccino maker;
- close the steam and put the rotating body back in position A;
- if the air intake hole (Y) is blocked, clear it gently with a pin.

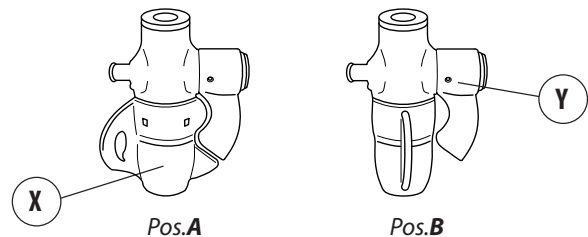

It is advisable to clean the cappuccino maker after each period of continued use so as to avoid malfunctions and to ensure a high rate of hygiene in the system.

# 15 Group washing

If provided for in the programming, the machine automatically requests that the washing of the delivery groups be carried out.

Attention: during this phase, all the coffee selections are disabled until the washing has been completed.

Follow the indications provided on the display:

GROUP WASHING  
PUT THE DETERGENT  
THEN PRESS  
STOP/PROG KEY.

- Use the solid filter;
- insert the detergent tab into the filter;
- attach the portafilter to delivery group 1;
- press the "**PROG/STOP**" key to start the washing phase;
- the following messages appear on the display in alternating sequence:

GR.1 WASHING ON  
GR.2 WAIT DETERGENT  
GR.3 WAIT DETERGENT  
GR.4

GR.1 WASHING ON  
GR.2 STOP/PROG KEY  
GR.3 STOP/PROG KEY  
GR.4 STOP/PROG KEY

- wait for the washing to be carried out until the following messages appear on the display:

GR.1 REMOVE FILTER  
GR.2 WAIT DETERGENT  
GR.3 WAIT DETERGENT  
GR.4

GR.1 STOP/PROG KEY  
GR.2 STOP/PROG KEY  
GR.3 STOP/PROG KEY  
GR.4 STOP/PROG KEY

- remove the portafilter from delivery group 1 and press the "**PROG/STOP**" key.
- wait for the rinse cycle to be carried out (this takes roughly 30 seconds), and the following messages will appear on the display:

GR.1 SWILLING ON  
GR.2 WAIT DETERGENT  
GR.3 WAIT DETERGENT  
GR.4

GR.1 SWILLING ON  
GR.2 STOP/PROG KEY  
GR.3 STOP/PROG KEY  
GR.4 STOP/PROG KEY

- at the end of the rinse cycle, the following messages will appear on the display:

GR.1 WASHING END OK  
GR.2 WAIT DETERGENT  
GR.3 WAIT DETERGENT  
GR.4

GR.1 WASHING END OK  
GR.2 STOP/PROG KEY  
GR.3 STOP/PROG KEY  
GR.4 STOP/PROG KEY

Carry out the washing operations on the other groups following the same procedures indicated above.

If desired, the washing request can be forced by pressing and holding the (◀) key of the programming selector for 5 seconds.

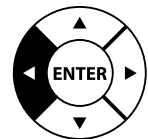

**i** The washing operations can also be carried out simultaneously on several delivery groups. To exit the washing phase, the washing must be completed on all the groups.



# 16 Checks and cleaning

## 16.1 Checks and maintenance

To ensure perfect safety and efficiency of the machine over time, it is necessary to carry out maintenance. In particular, **it is advisable to ask the Technical Service to carry out an overall check of the machine at least once a year.**

Checks	Daily	Weekly	Monthly
<b>MACHINE</b> <ul style="list-style-type: none"> <li>Using the machine's display, check that the pump pressure indicated is around 8-9 bar.</li> <li>Check that the boiler pressure indicated on the display is consistent with a programming value.</li> <li>In case of anomalies, contact the Technical Support Service.</li> </ul>	X		
<b>PORTAFILTER FILTERS</b> <ul style="list-style-type: none"> <li>Check the wear of the filters, if there is damage to the edges and check if coffee grounds are getting into the cup. If necessary replace the filters.</li> </ul>		X	
<b>GRINDER-DOSER</b> <ul style="list-style-type: none"> <li>Check the dose of the ground coffee, which should be about 6-7 gr. at a time, and adjust the amount as necessary.</li> <li>Check the degree of grinding and modify as required.</li> <li>Check the grinders for wear: they should be replaced if there is too much powder in the ground coffee.</li> </ul>		X	
<b>SOFTENER</b> <ul style="list-style-type: none"> <li>Carry out regeneration of the softener (for the manual softener).</li> <li>Check that there is salt in the container (for the softener in the automatic version).</li> </ul>		X	

## 16.2 Cleaning

For perfect hygiene and efficiency of the unit, a few simple cleaning tasks are required.

The indications given here are applicable for normal use of the coffee machine. If the machine is used intensively, then cleaning should be performed more frequently. When cleaning, always use cloths that are completely clean and hygienic.

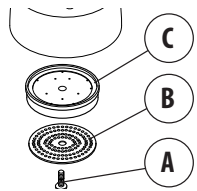
Cleaning	Daily	Weekly	Monthly
<b>CAPPUCCINO MAKER</b> Clean several times a day as indicated in par. 14.2, especially if used continuously.	XXX		
<b>FILTERS and PORTAFILTERS</b> Use a screwdriver to detach the filter from the portafilter. Clean the inside of the portafilter with a brush and wash the filter and portafilter with hot water. Failure to clean the filters and portafilters will compromise the quality of the coffee and also cause problems such as bad extraction and coffee grounds at the bottom of the cup.	X		
<b>STEAM NOZZLE / AUTOSTEAMER</b> Keep the nozzle clean at all times using a cloth dampened in lukewarm water.	X		
<b>STEAM NOZZLE / AUTOSTEAMER TERMINALS</b> Check and clean the tips of the nozzle, clearing out the steam outlet holes with a small needle.			X
<b>BODY</b> Clean the panels of the body with a cloth dampened in lukewarm water. Do not use abrasive detergents which may scratch the surface of the body.	X		
<b>PERFORATED DISK and CONTAINMENT RING</b> Loosen the screw (A) and Remove the perforated disk (B) and the containment ring (C) from the dispensing group. Wash with hot water. 		X	

Cleaning	Daily	Weekly	Monthly
<p><b>DISPENSER UNIT</b></p> <p>Carry out the washing of the groups as indicated in Chapter 15 and follow the instructions below:</p> <ul style="list-style-type: none"> <li>• use the solid portafilter;</li> <li>• pour the detergent on the solid filter and attach the portafilter;</li> <li>• Carry out a series of deliveries until the water comes out clean;</li> <li>• remove the portafilter from the unit and carry out at least one delivery so as to eliminate the detergent residue.</li> </ul>	X		
<p><b>GRINDER-DOSER</b></p> <p>Clean the inside and outside of the receptacle and the doser of the grinder-doser with a cloth dampened in lukewarm water.</p>		X	

- **During the cleaning operations, pay attention to the parts of the machine that are overheated.**
- **To guarantee the correct operation and hygiene of the machine, it is necessary to use the cleaning methods and products suitable for this purpose.**
- **Do not immerse the machine into water.**
- **Never use alkaline detergents, solvents, alcohol or aggressive substances.**
- **The descaling of the machine has to be performed by specialized technicians, by dismantling the components with deposits, so that no descaling debris are put into circulation. The used products/ detergents have to be suitable for this purpose and must not corrode the materials of the hydraulic circuits.**



## 17 Suggestions on how to obtain a good cup of coffee

To obtain high-quality coffee, it is important that the hardness of the water used does not exceed 4-5 °F (French degrees). If the water hardness exceeds these values, it is advisable to use a water softener.

Avoid using a water softener if the water hardness is less than 4 °F.

If the taste of chlorine in the water is particularly strong, a special filter should be installed.

It is not advisable to keep large stores of coffee beans. Never grind large amounts of coffee. Use the amount the doser holds and if possible use it by the end of the day. Never purchase ground coffee as it expires quickly.

After the machine has not been used for a period of time (2-3 hours) make a few dry runs.

Be sure to carry out regular cleaning and maintenance.

Once the portafilter has been attached to the group, dispense as soon as possible.

If the type of coffee will be changed, it is recommended that you contact the Technical Support Service for the water temperature adjustment.

Adjust the grinding of the coffee according to the degree of humidity in the environment.

## 18 List of hazards

This chapter describes possible hazards for the user if the specific safety standards (described in this manual) are not adhered to.

### **The appliance must be connected to an efficient grounding system**

If this is not done, the appliance can be a source of dangerous electrical discharges as it is no longer able to discharge electricity to earth.

### **Do not use running water for washing**

The use of pressurized water directly on the machine can seriously damage the electrical equipment. Never use water jets to wash any part of the appliance.

### **Do not touch the dispenser unit**

The high temperature of the dispenser unit may cause burns. Avoid contact of the dispenser unit with the hands or other parts of the body.

### **Be careful of the steam and hot water nozzles**

During use, the steam and hot water nozzles become very hot and are thus a potential source of danger.

Handle these parts carefully. Never direct steam or hot water jets directly on parts of the body.

### **Do not work on the machine**

Do not carry out any operation on the appliance, and never remove any panel of the body.

In case of breakdowns or poor functioning, turn the appliance off, disable the electric and hydraulic power supply, using the apposite mains switches located upstream from the machine.

Do not attempt any sort of repair, contact the technical service instead.

**If you should decide not to use the appliance,** it is necessary to shut it down by disconnecting the power supply cable from the electrical mains, closing the inflow of water from the hydraulic mains and emptying the hydraulic system.

For the operations of disconnection from the electrical and hydraulic mains and of release of the water, qualified personnel has to be contacted.

### **Use of the appliance**

This espresso coffee machine is an appliance for professional use only.

Any other type of use is considered incorrect and therefore dangerous. Never allow children or people not familiar with it to use the machine.

**Non-observance of the above-described standards can cause serious harm to people, property or animals.**

**Never work on the electronic apparatus when the machine is still supplied with electrical energy.**

**Shut down the machine completely by disconnecting it from the mains before carrying out any operation.**

# 19 Display indications

GR.X FLOW TOO FAST  
CONSULT THE HANDBOOK

- Coarse grinding: reduce the grinding degree.
- Short coffee dose: adjust the dose on the grinder-doser.
- Ground coffee too old: use fresh-ground coffee.
- Ambient humidity lower than usual: slightly reduce the grinding degree.

GR.X FLOW TOO SLOW  
CONSULT THE HANDBOOK

- Fine grinding: increase the grinding degree
- Long coffee dose: adjust the dose on the grinder-doser
- Ambient humidity higher than usual: slightly increase the grinding degree
- Hydraulic circuit obstructed: contact the Technical Support Service

GROUP WASHING

- The group washing needs to be carried out as indicated in paragraph 15.

ENERGY SAVING

- All the groups are in stand-by or the entire machine (including the services boiler) is in energy savings phase.

+ flashing of the STOP/PROG LEDs

-- OFF --

- The machine is off in automatic mode.

*The LED of the STOP/PROG key remains lit constantly.*

- Delivery group off.

*The LED of the STOP/PROG key is flashing*

- One or more delivery groups (but not all) are in stand-by.



**If indications other than those indicated above should appear or if the machine presents any type of failure, turn the machine off and contact the Technical Support Service. Any repairs that are not carried out by an authorised service centre, in addition to compromising the machine's safety, may seriously damage the equipment and render the guarantee null and void.**







**WEGA** s.r.l.

Via Condotti Bardini, 1 - 31058 SUSEGANA (TV) - ITALY  
Tel. +39.0438.1884811 - Fax +39.0438.1884890  
www.wega.it - info@wega.it

Cod. WY02000222 - Rev. 00 - 02/2011