

ZERO+ Quick Milk

Entry-Level Super Automatic Espresso Machine with Countertop Fridge

Versatile and multifunctional, Egro ZERO+ Quick Milk accommodates up to 16 different high-quality espresso beverages and is equipped with an easy-to-use keypad interface. This medium-to-low volume super automatic espresso machine is perfect for adding espresso to any restaurants' breakfast or dinner menu. It grinds, tamps, brews, and extracts fresh authentic espresso on demand. The water for the Americano is delivered separately, before or after the espresso is brewed, and does not run through the brew chamber, producing authentic Americanos at the push of a button. Dual grinders from Ditting® and an 18-gram brew chamber enable this machine to deliver the best espresso of any super automatic in its class. Milk is delivered from a side refrigerator which holds up to 1 gallon of milk. The smaller countertop fridge is made from lightweight yet hard-wearing materials, the stainless-steel door has a brushed finish, and it holds up to 1 gallon of milk. This unit is the perfect addition to any independent or chain restaurant, hotel, or resort where quality and consistency is important and daily drink volumes are expected to be less than 100 cups a day.



Standard Features

- Grinds, tamps, brews, and extracts fresh authentic espresso on demand
- Centralized hot water outlet with different temperature options
- Americano bypass enables machine to deliver authentic Americanos into a single cup
- Back-lit keypad interface with 16 drink options
- Stainless steel 18-gram patented brew group
- Easy step-by-step daily cleaning program
- Dual Ditting® grinders with stainless steel burrs
- Made of painted steel and ABS plastic
- Single component two-piece dispensing outlet for easy cleaning
- 2 year parts warranty

Accessories in the Box

- Plastic grounds bin container
- One-month supply of daily cleaning products
- User manual
- Foot extensions

Options

Tank Version: Self-contained water reservoir and drain reservoir

Under Counter Grounds Chute: Chute that diverts ground coffee to an under counter waste container

External Hot Water Outlet: Hot water delivered through a separate outlet to the right of the drink spout

Self-Service Package: Includes locks for hoppers and grounds drawer, as well

External Hot Water Outlet: Hot water delivered through a separate outlet to the right of the drink spout

Self-Service Package: Includes locks for hopper, grounds drawer, and fridge, as well as cup stopper pins for the drink tray

Powder Module: Enables machine to deliver up to 2 types of powder, such as chocolate for mochas and for hot chocolate

Space Requirements

Allow at least one and a half inches (1.5") of clearance from the back of the machine to the nearest wall for air circulation.

Allow at least four inches (4") of clearance above hoppers to refill. (recommended 12")

Allow 24" x 5" for in-line filter. Filter can be mounted behind the machine or under the counter.

ZERO+ Quick Milk

Entry-Level Super Automatic Espresso Machine with Countertop Fridge

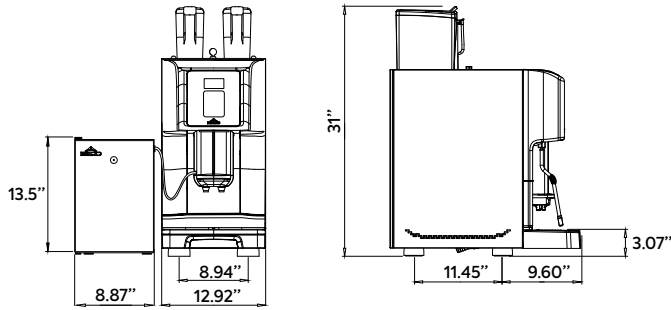

Countertop Requirements

Espresso Machine with Countertop Fridge

Width	Depth	Height	Weight
22"	24"	31"	130 lbs

Shipping Dimensions and Weight

Espresso Machine

Length	Width	Height	Weight
36"	36"	33"	183 lbs

Countertop Drilling Plan

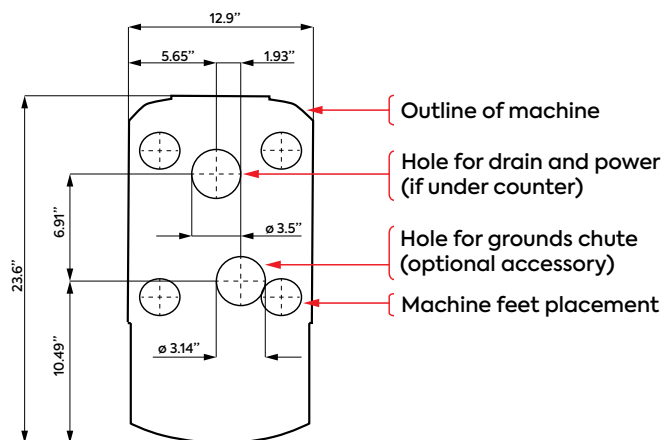

Electrical Connections

Espresso Machine

Voltage Range: 110-120VAC

Power: 1800W

Circuit Size: 20A

Suggest Receptacle: 5-20R

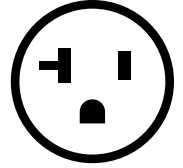

Countertop Fridge

Voltage Range: 110-120VAC

Power: 86W

Circuit Size: 15A

Suggest Receptacle: 5-15R GFI

NOTE: Egro machines do not use a neutral line. A dedicated ground wire is required.

Power can be installed under or above the counter. Please allow 3.5"-4" of space for the plug, especially when placing power above the counter and behind the machine.

Water Connections

Dedicated cold water access line with standard female 3/8" NPT fitting and manual shut-off valve within 4' of the machine required.

Drain Requirements

Open gravity drain with minimum 2" I.D. within 4' of the machine.

Water Quality Statement

The fact that water is potable is no guarantee that it is suitable for coffee machines. Your water supply must be within these general guidelines:

SUPPLY PRESSURE: 30-70 psi

HARDNESS: 2-3 GPG (1 grain of hardness = 17.1 ppm)

Water entering the machine should have a water hardness level of 2-3 GPG at all times. If the water supply is not within this range, a dedicated water softener (if above 3 GPG) or mineral addition cartridge (if below 2 GPG) is required for the coffee machine to operate properly over time (see Rancilio Group North America Water Quality Statement for further details).

Ditting is a registered trademark of Ditting Maschinen AG.

