



# LOW LEVEL ROOM SCAFFOLD

ISSUE 3

## Low Level Access Platform

### Instruction Manual EN 1298-IM-EN

The Room Scaffold System is certified to BS 1139-6:2014



# Introduction

Please read these instructions carefully and ensure that you fully understand all of the information contained herein. All of the information in this document is vital for the safe utilisation of your Room Scaffold.

All products are professional quality engineered equipment designed primarily with safety in mind and meet or exceed all standards, recommendations and guidelines. Used properly, the equipment will keep you safe when working at height.

This manual contains all of the information necessary to correctly assemble your Room Scaffold in accordance with BS 1139-6:2014 and incorporates all of the requirements of the PASMA 3T method of assembly as endorsed by the HSE.

This manual should be used in conjunction with your Risk Assessment and Method Statement and in line with the Work at Height Regulations 2005 which place an obligation on employers to eliminate or minimise risks. This manual must be made available to the user/assembler at all pertinent times.

Only competent and qualified personnel should undertake erection, dismantling or alteration, organisation, planning or supervision of mobile access towers. In the case of any doubt, sufficient relevant additional training must be given beforehand to ensure safe use. For further information on the use of mobile access towers consult PASMA ([www.pasma.co.uk](http://www.pasma.co.uk); Tel +44 (0) 845 230 4041).

For any additional technical information or specific advice please contact LEACH'S  
Tel: +44 (0)1432 346 800 or Email: [sales@leachs.com](mailto:sales@leachs.com)

## Certifications

The Room Scaffold is a mobile access tower outside the scope of EN 1004 and within the scope of BS 1139-6:2014.

This tower is manufactured in our ISO 9001 accredited facility.

This manual complies with EN 1298-IM-EN.

## Maximum Safe Working Loads

The safe working load of Room Scaffold is 282kg. The maximum leg load imposed by the tower on its supporting surface is 90kg when loaded to its maximum safe working load.

In case of any queries on loadings, contact your supplier - LEACH'S, for advice. Tel: +44 (0)1432 346 800 or Email: [sales@leachs.com](mailto:sales@leachs.com)

# Inspection Care & Maintenance

The equipment is designed and manufactured to the highest standards in the industry and is stronger, more robust and safer than any comparable competitor product. Properly cared for, it will give a long and productive service life.

All equipment should be subjected to the care and maintenance regime specified in the assembly guide supplied with your Room Scaffold.

Never use any equipment which is damaged, has parts missing or is improperly assembled.

## Safety

- A risk assessment and method statement must be prepared sufficient to ensure the safe assembly, use and dismantling of a Room Scaffold and the elimination or minimisation of all consequent risks.
- Check that all of the necessary components and equipment for the particular Room Scaffold configuration to be built are on site, undamaged & functioning correctly. Damaged/incorrect components must not be used.
- Check that the surface on which the Room Scaffold is to be located is capable of supporting the Room Scaffold and its payload.
- Room Scaffolds must always be climbed from the inside.
- Do not ride on or attempt to move a loaded Room Scaffold
- Never remove components from a Room Scaffold whilst it is in use.
- Do not lean ladders, steps or other objects against the Room Scaffold.
- The Room Scaffold may not be used as a means of access to another place.
- Do not overreach.
- Always wear appropriate personal protective equipment and work-wear including foot wear with a flat firm sole and a good grip.
- The Room Scaffold is only to be used on level ground. Do not adjust the height using adjustable legs.
- Always take safety measures when working close to doorways, openings and other traffic paths, to prevent accidental collisions. Never block emergency exits, fire-paths or other escape routes.
- Always comply with the Work at Height Regulations 2005 when erecting, dismantling & using the Room Scaffold.
- Never use this Room Scaffold until you are sure you are competent in its use and physically able to safely enter, exit and work from the platform.
- Never use the Room Scaffold if you are feeling unwell or you have taken any alcohol, medication or other substance that may affect your ability to work safely.

- Never carry out jobs that require excessive sideways force. Forces should never exceed 30kg. Excessive sideways forces may cause the work station to tilt or overturn.
- Never suspend the Room Scaffold from another structure.
- Beware live electrical installations, cables, moving machinery or other obstructions when erecting, dismantling or using the Room Scaffold. The Room Scaffold is a conductive metallic structure.
- Do not use boxes, ladders or other items to gain additional height.
- Do not stand on guard rails for any reason.
- The Room Scaffold is not to be used in connection with hoisting arrangements.
- Fit guard rails and toe boards to all Platforms.
- Every erected Room Scaffold must be inspected at least every seven days and any Room Scaffold which has been left unattended should be inspected before use to ensure that:
  - 1 no components have been removed or relocated incorrectly;
  - 2 the Room Scaffold is still vertical; and
  - 3 no environmental or other factors have arisen which will influence safe use of the Room Scaffold.

## Erecting & Dismantling the Tower

Room Scaffolds must be built and dismantled in accordance with the step by step instructions set out below and having regard to the working at height regulations and Health & Safety legislation.

## Moving the Room Scaffold

No persons, tools, equipment or materials shall be permitted to remain on the Room Scaffold when it is being moved. The Room Scaffold should only be moved by pushing it by the lowest frames at approximately shoulder level. When moving the Room Scaffold users are to be particularly careful of the following:

- obstructions, moving machinery or electrical cables and equipment.
- not to move the Room Scaffold in wind speeds of 18mph (force 5) or above.
- the effect of rough, uneven or sloping ground on the stability of the Room Scaffold.
- locking and unlocking the castors to allow and prevent the Room Scaffold moving at appropriate times.
- after completing the movement, use a spirit level to ensure that the Room Scaffold is vertical and safely supported on an appropriate surface.
- after completing the movement check that the Room Scaffold is correct and complete.

# 3T Method Explained

The “3T” or “through the trapdoor” method is one of the two permitted ways of assembling a tower without the assembler being at risk of falling. This tower is a 3T tower.

## Step 1:

As each new level of platform is installed, the operative takes up a working position in the trap door of the platform, standing on the ladder and leaning back against the edge of the trapdoor aperture.

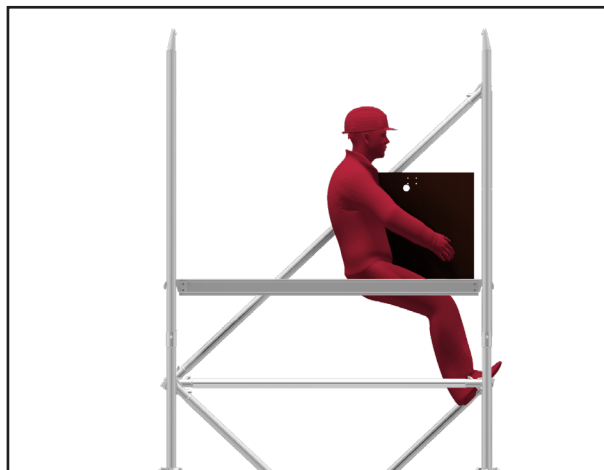

## Step 2:

From this position the operative fits the horizontal braces 500mm and 1000 mm above the platform level (i.e. on the first and third available rungs). If the far end of the guardrail braces don't fully engage when they are put in place, the operative fully engages it when first climbing up onto the platform. This process ensures that operatives never have to stand on an unguarded platform.

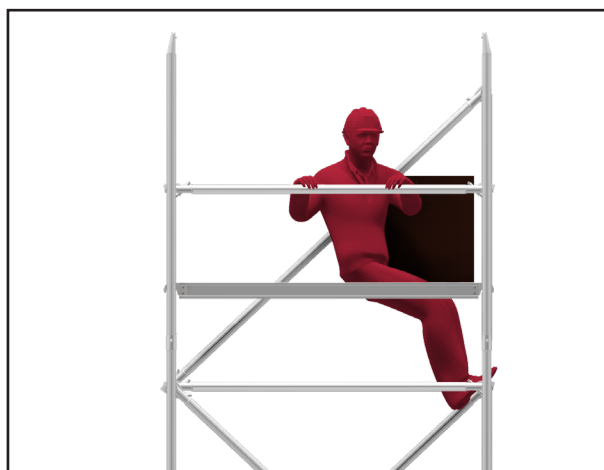

## Signage

The following information shall be prominently displayed at the base of the assembled tower:

The maximum number of working platforms	One
The maximum number of persons permitted on the working platforms	2 persons per platform
The maximum number of persons permitted on the tower during assembly and dismantling	2 persons per platform
The maximum safe working load on working platforms	282kg per platform unit
The maximum safe working load of the tower	282kg per platform unit
The load class of the tower	Class 3

# Component Schedule

## 1.6m Long Room Scaffold Frame

CODE	PART DESCRIPTION	Weight	PLATFORM WORKING HEIGHT (m)					
			0.41m	0.66m	0.91m	1.16m	1.41m	1.66m
3069	Room Scaffold 1.6m Folding Frame	17.0	1	1	1	1	1	1
2239	125mm Dia. Castor Wheel	2.5	4	4	4	4	4	4
3021	MD 1.6m Trap Platform	13.1	1	1	1	1	1	1
3015	MD 1.6m Horizontal Brace (blue)	1.8	2	2	3	3	4	4
3058	Room Scaffold 1 Rung Ext. Frame	1.2			2			
3057	Room Scaffold 2 Rung Ext. Frame	2.0				2		
3054	Room Scaffold 3 Rung Ext. Frame	3.0					2	
3053	Room Scaffold 4 Rung Ext. Frame	3.8						2
3516	Low Level Stabiliser	4.0	4*	4*	4*	4	4	4
3036	MD 1.6m S/W Toeboard	7.3	1*	1*	1*	1	1	1
<b>TOTAL SELF WEIGHT (kg)</b>			44 (67*)	44 (67*)	48 (71*)	73	77	78

\* = Recommended unless your risk assessment deems these parts to be unnecessary.

## 2.4m Long Room Scaffold Frame

CODE	PART DESCRIPTION	Weight	PLATFORM WORKING HEIGHT (m)					
			0.41m	0.66m	0.91m	1.16m	1.41m	1.66m
3073	Room Scaffold 2.4m Folding Frame	22.0	1	1	1	1	1	1
2239	125mm Dia. Castor Wheel	2.5	4	4	4	4	4	4
3022	MD 2.4m Trap Platform	18.2	1	1	1	1	1	1
3017	MD 2.4m Horizontal Brace (yellow)	2.6	2	2	3	3	4	4
3058	Room Scaffold 1 Rung Ext. Frame	1.2			2			
3057	Room Scaffold 2 Rung Ext. Frame	2.0				2		
3054	Room Scaffold 3 Rung Ext. Frame	3.0					2	
3053	Room Scaffold 4 Rung Ext. Frame	3.8						2
3516	Low Level Stabiliser	4.0	4*	4*	4*	4	4	4
3037	MD 2.4m S/W Toeboard	10.8	1*	1*	1*	1	1	1
<b>TOTAL SELF WEIGHT (kg)</b>			55 (82*)	55 (82*)	60 (87*)	89	93	95

\* = Recommended unless your risk assessment deems these parts to be unnecessary.

## ASSEMBLY INSTRUCTIONS - 0.41m & 0.66m Platform heights

### STEP 1



Install 4 wheels into the base of the folding frame. Once fitted unfold the frame and ensure that the back framework is locked open. Now apply the brakes to the wheels.

### STEP 2



Install the platform onto the appropriate height rung on the folding frame. Make sure the wind latches on both ends of the platform are applied. Now fit 2 horizontal braces to the outside face of the frame on the 2nd and 4th rung up from the platform.

### STEP 3



Finally fit the toeboard unit to the platform.

## ASSEMBLY INSTRUCTIONS - Platform heights 0.91m & above

### STEP 1



Install the wheels and lock frame open as detailed in step 1 above. Make sure the wheels are braked. Next, install the platform onto the appropriate height rung on the folding frame. Make sure the wind latches on both ends of the platform are applied.

### STEP 2



Fit into the top of the folding frame the correct extension frames as specified in the component schedule. Make sure the conical head fitting is pointing the right way so the node fits through the hole in the folding frame. Fit 4 stabilisers to the folding frame.

### STEP 3



Now using the 3T method, fit the correct number of braces as specified in the component schedule to ensure that a guard rail is located on both sides of the platform at 0.5m and 1m heights. Finally fit the toeboard to the platform.

# Moving

The Room Scaffold can be left fully assembled when moving.

To move the Room Scaffold, first adjust the upper arm of the stabilisers so the foot lifts off the ground. Now, release the brakes on the wheels and reposition the Room Scaffold into the new Location. If moving the Room Scaffold through a doorway or confined space, the stabilisers and/or the extension frames may have to be removed. See below for dismantling instructions.

Always take care and check your surroundings when you are moving the Room Scaffold.

# Dismantling

When dismantling the Room Scaffold, follow the above instructions in reverse.

Always take care and check your surroundings when you are dismantling the Room Scaffold.



# Components



3069 shown

**3069 - 1.6m Folding Frame**  
**3073 - 2.4m Folding Frame**

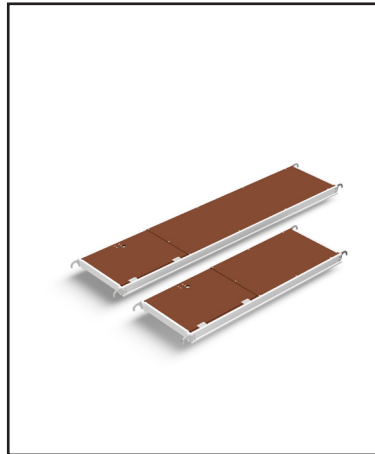

**3021 - 1.6m Trap Platform**  
**3022 - 2.4m Trap Platform**



**3015 - 1.6m Horiz. Brace (blue)**  
**3017 - 2.4m Horiz. Brace (yellow)**

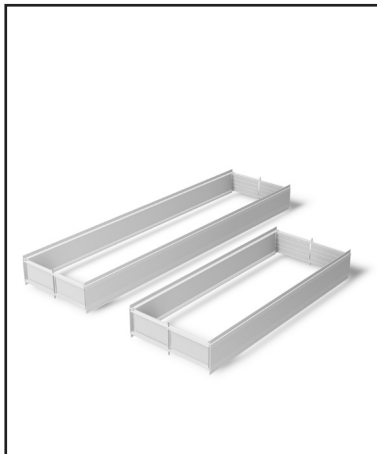

**3036 - 1.6m S/W Toeboard**  
**3037 - 2.4m S/W Toeboard**

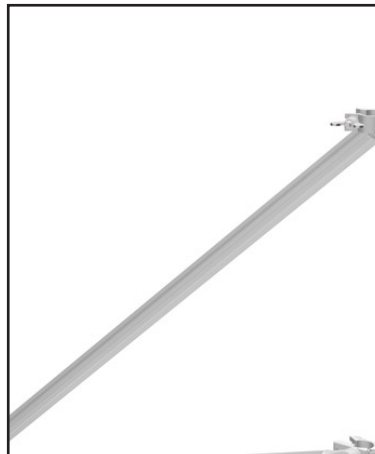

**3516 - Low Level Stabiliser**

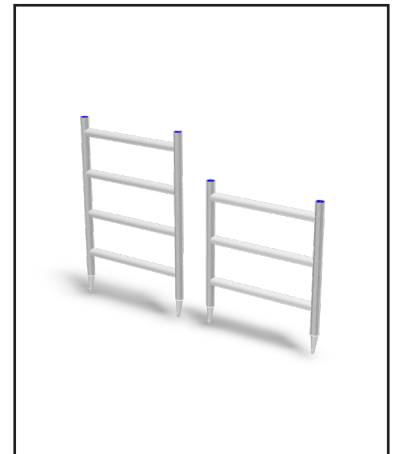

**3053 - 4 Rung Ext. Frame**  
**3054 - 3 Rung Ext. Frame**

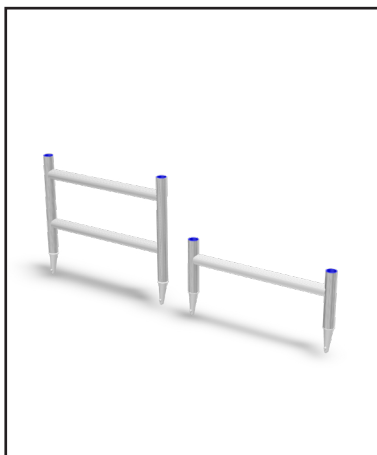

**3057 - 2 Rung Ext. Frame**  
**3058 - 1 Rung Ext. Frame**

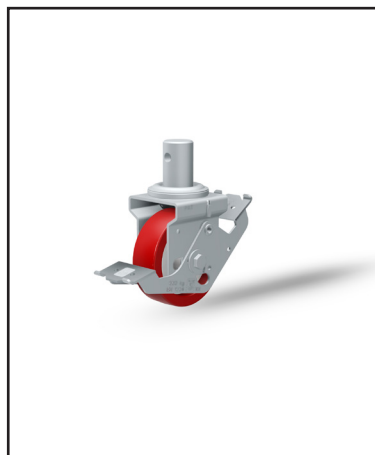

**2239 - 125mm castor wheel**

# Notes

# Notes

# THE HEIGHT OF SAFETY

For further information regarding our range of access products and services, please get in touch with us:

LEACH'S  
Beacon Park,  
228 Holme Lacy Road,  
Hereford  
HR2 6BQ  
t: +44 (0)1432 346 800  
e: sales@leachs.com  
w: www.leachs.com



Manufacturing Member