

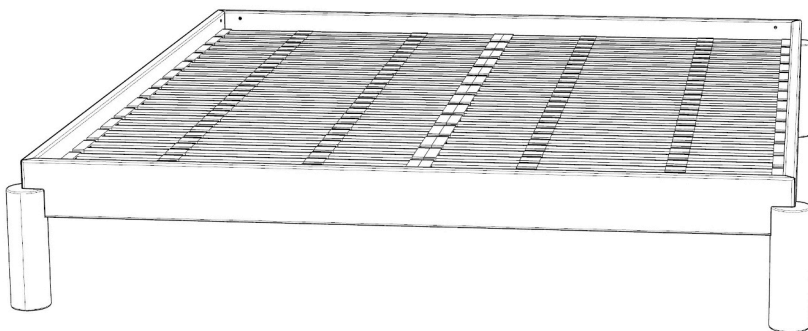







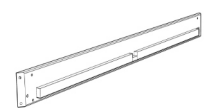
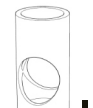
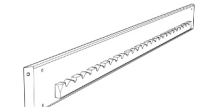

Handleiding 18° bed

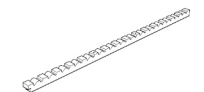

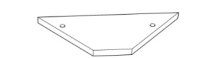
selé

In aanvulling op onderstaande stappen geven we je graag een aantal tips voor het beste resultaat en ter voorkoming van schade:

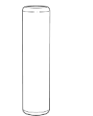
1. Gebruik een kleed om krassen te voorkomen.
2. Draai de bouten niet te hard aan. Geef enige druk, maar zet geen kracht.
3. Draai de onderdelen bij stap 6 en 7 eerst voor zo'n 80% aan.
4. Kijk vervolgens of de hoeken goed aansluiten (boven en onder).
5. Mocht een hoek niet goed aansluiten dan komt dat waarschijnlijk doordat bepaalde onderdelen steviger zijn aangedraaid dan andere.
6. Stel deze onderdelen door ze lossen en/of steviger vast te draaien, totdat de hoeken goed aansluiten en voor 100% aangedraaid zijn.
7. Voer stap 12 uit met 2 personen (omdraaien bed).
8. Kom je er niet uit? Neem gerust contact met ons op via support@studiosele.com, ook met je telefoonnummer en dan bellen we je zo snel mogelijk terug.

	2x		16x
	2x		16x
	1x		8x
	8x		26x
	4x		2x
	2x		8x
	30x - 32x*		1x

*afhankelijk van de lengte van het bed

1

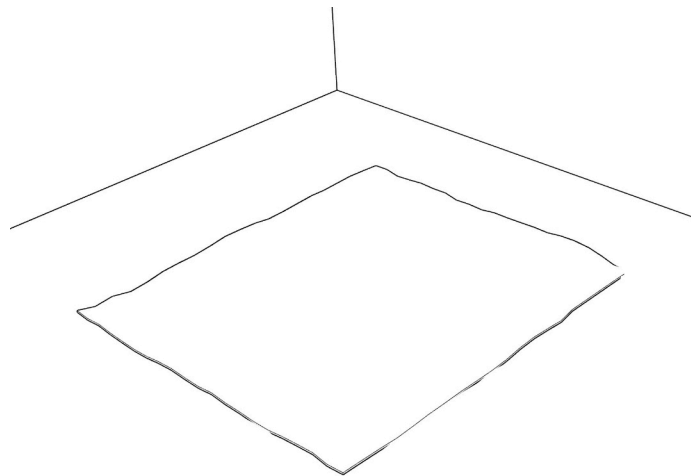

2

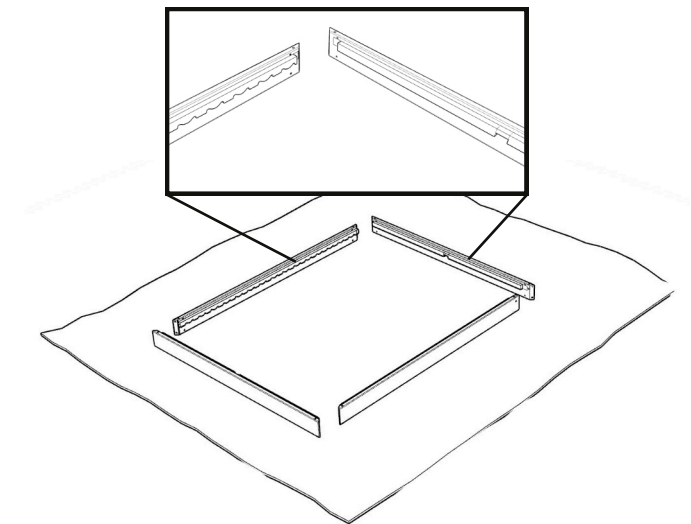

selé

3

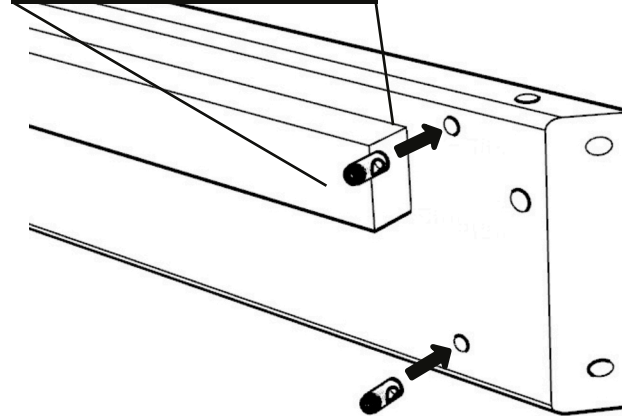
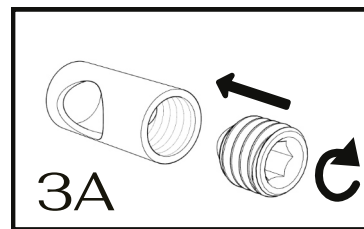
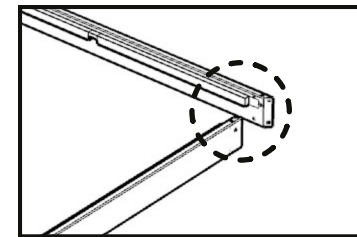
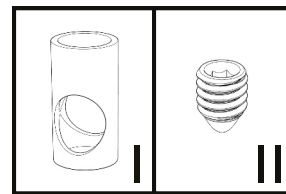

3B

selé

4

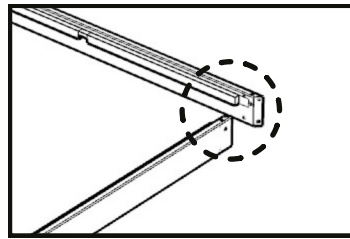
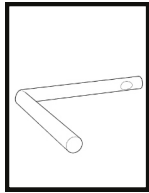

5

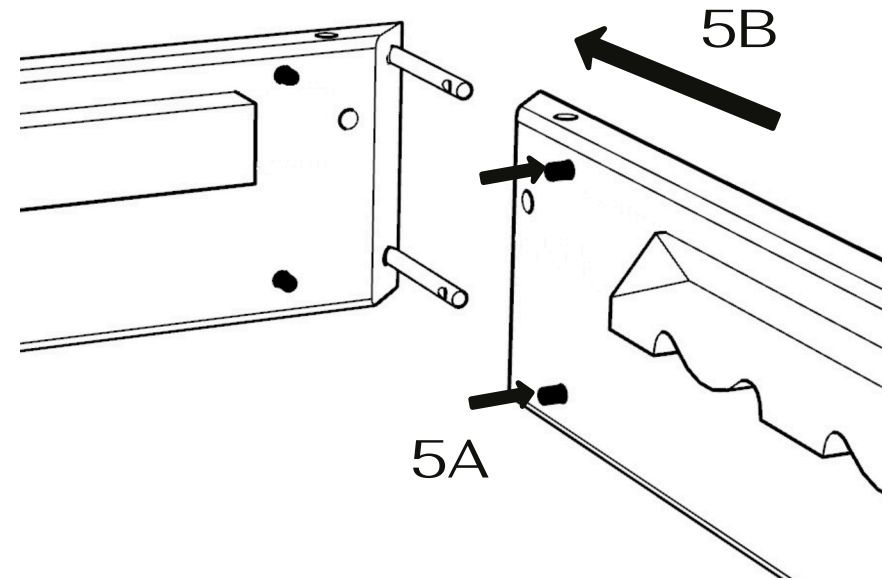
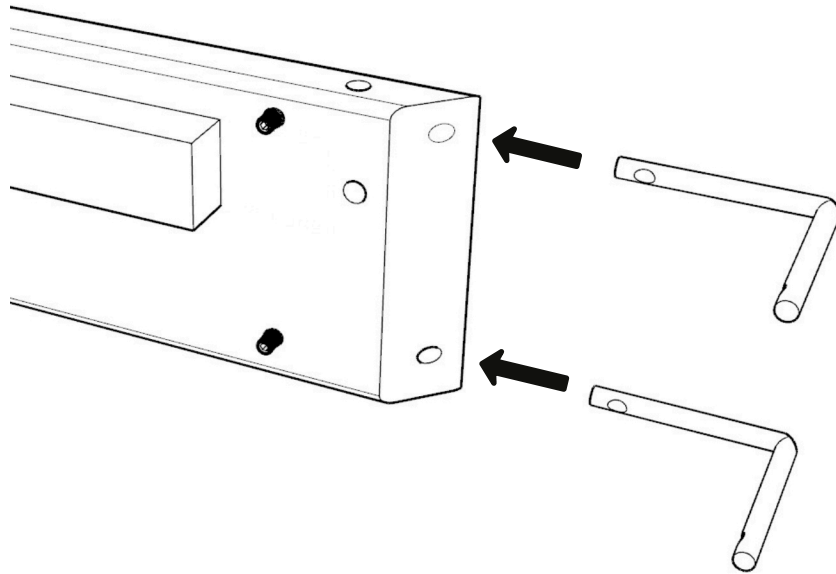
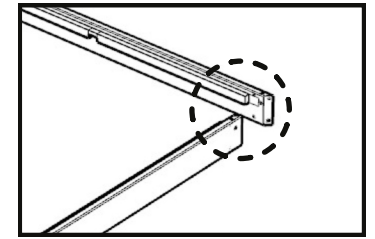
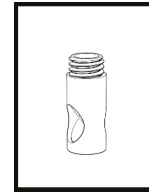

6*

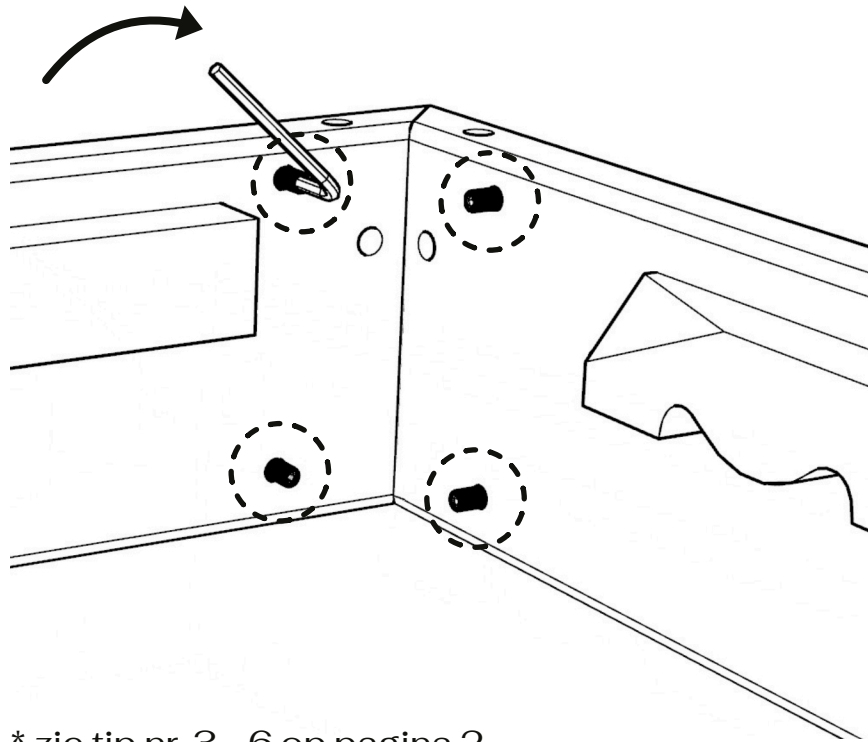
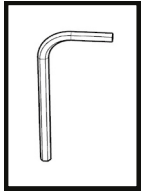

* zie tip nr. 3 - 6 op pagina 2.

selé

7*

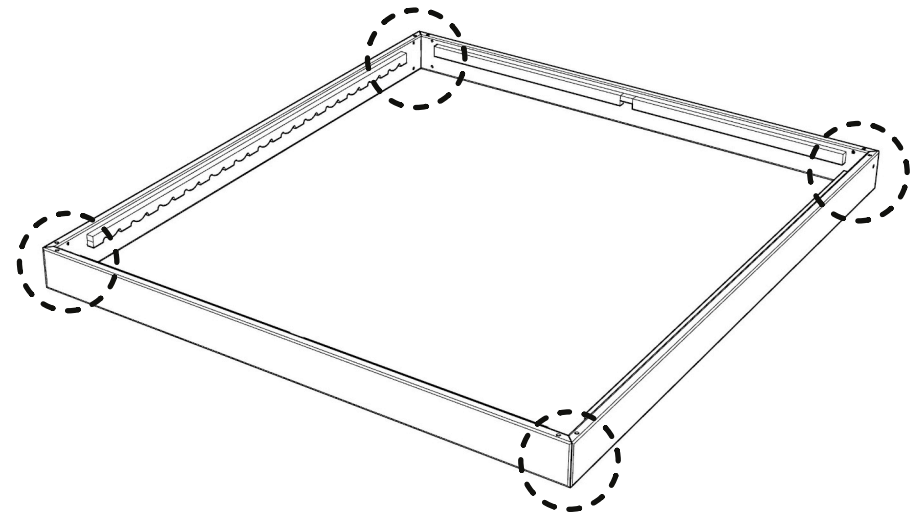
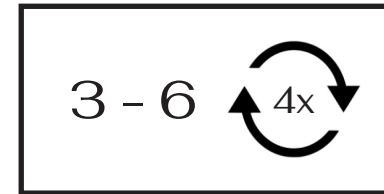

* zie tip nr. 3 - 6 op pagina 2.

selé

8

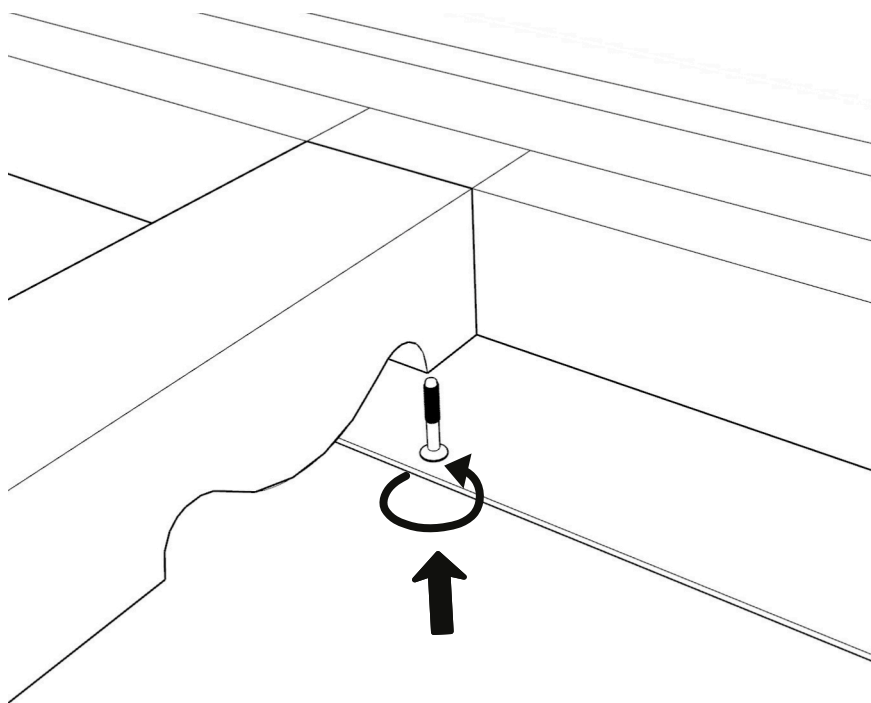
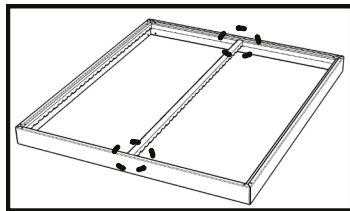
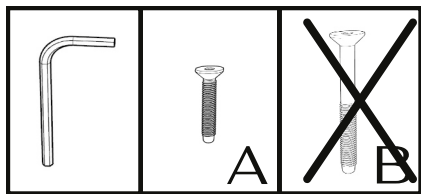

selé

9

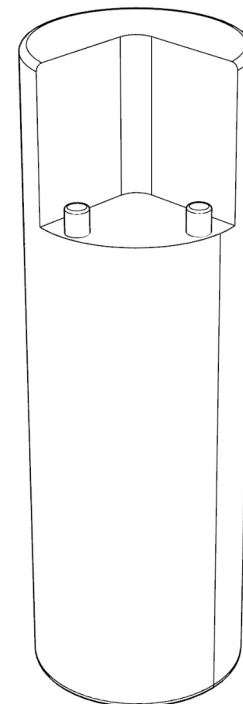
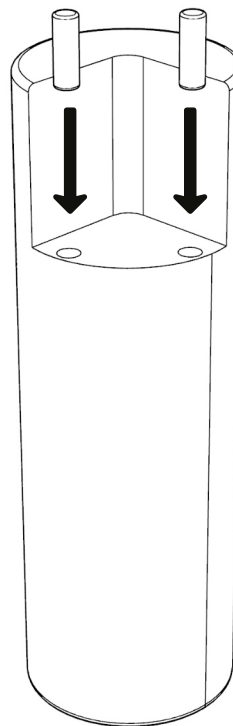
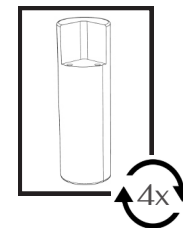
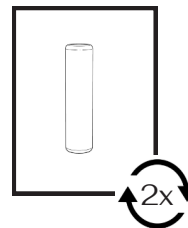

selé

10

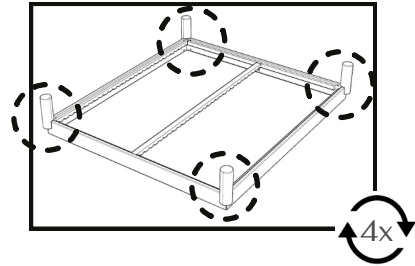
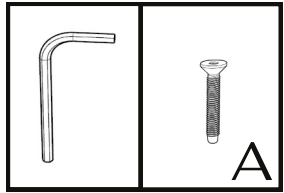

11

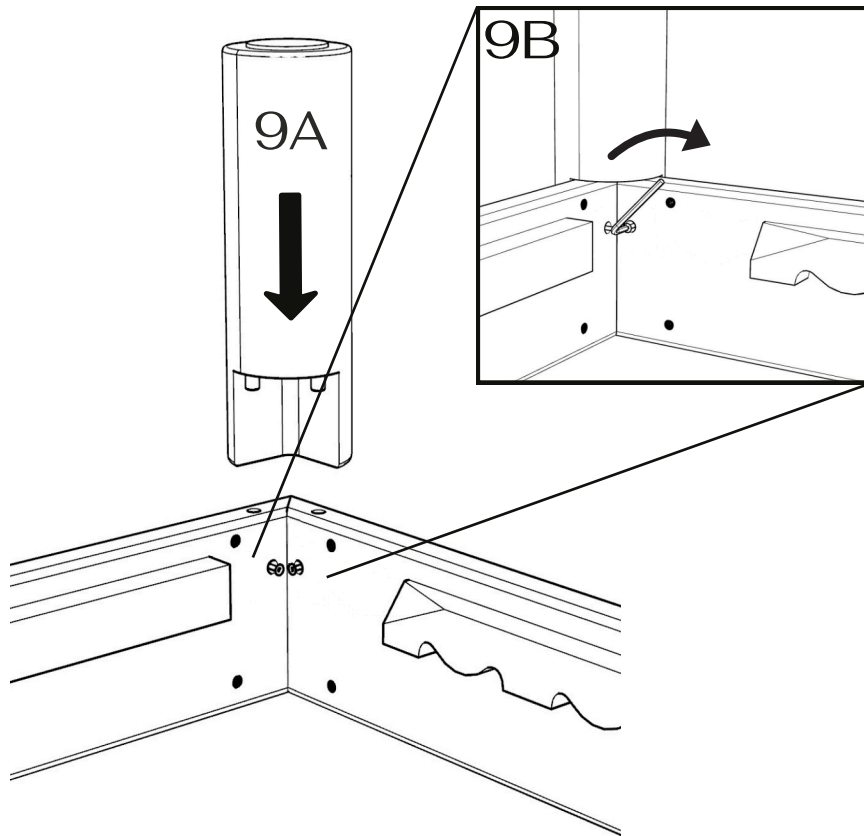
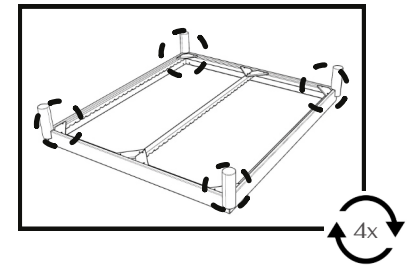
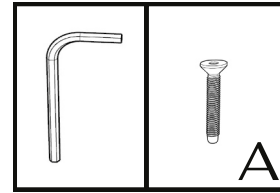

selé

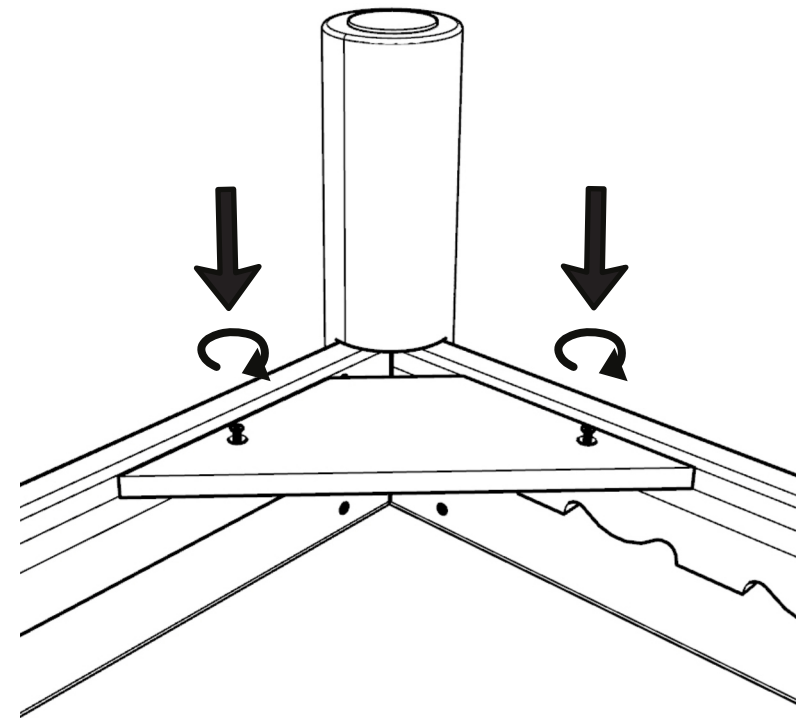

selé

12

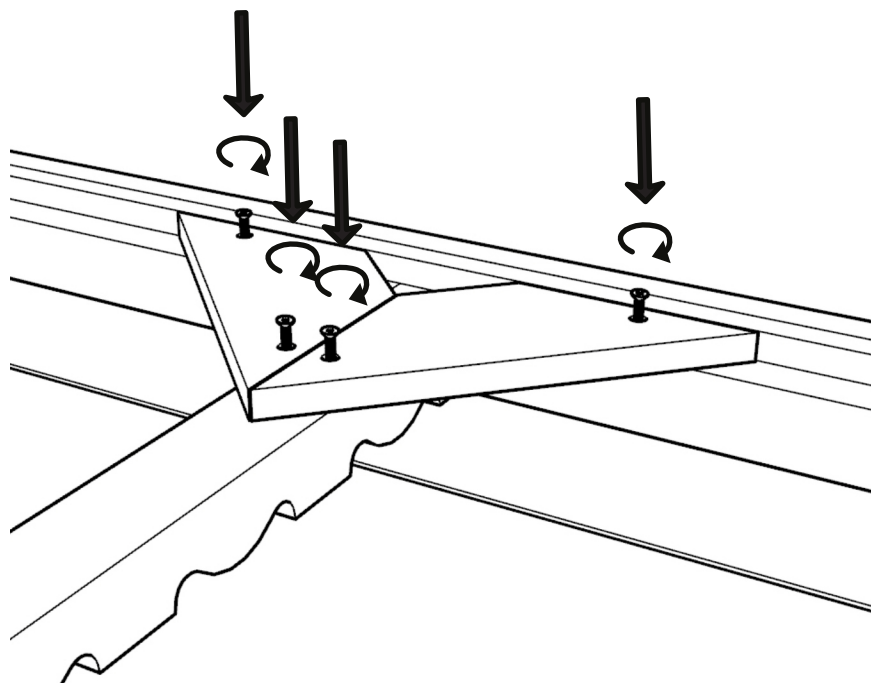
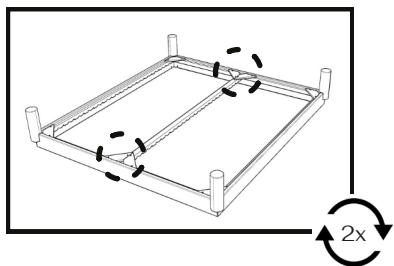
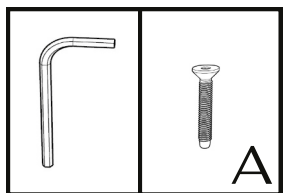

13

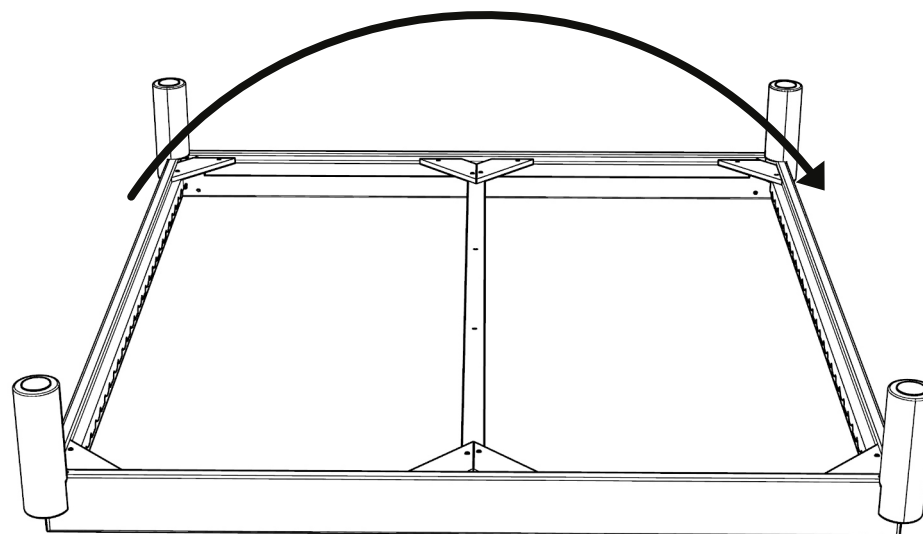

14

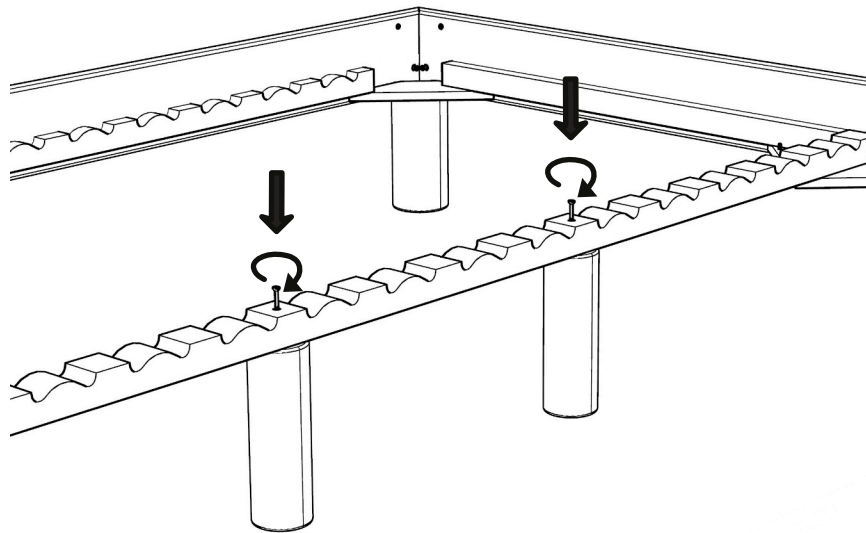
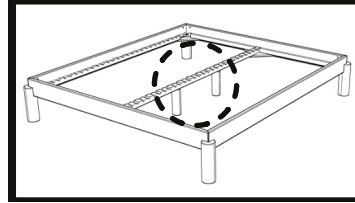
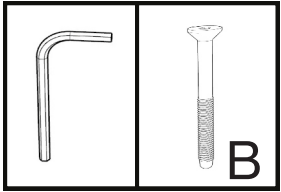

selé

15

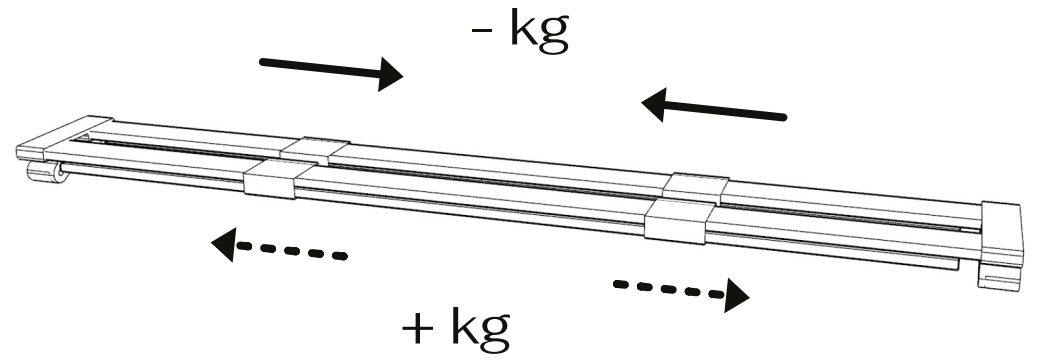

selé

16

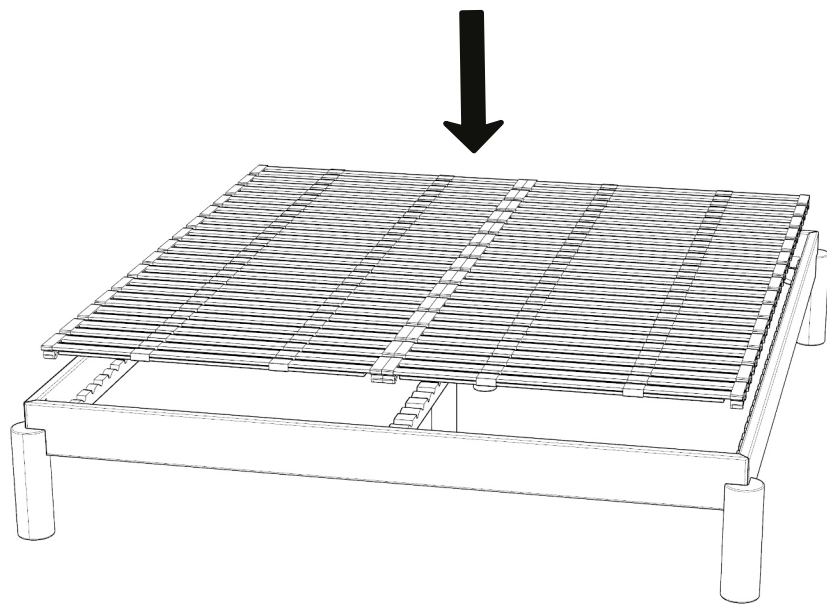

Selé

support@studiosele.com

www.studiosele.com