

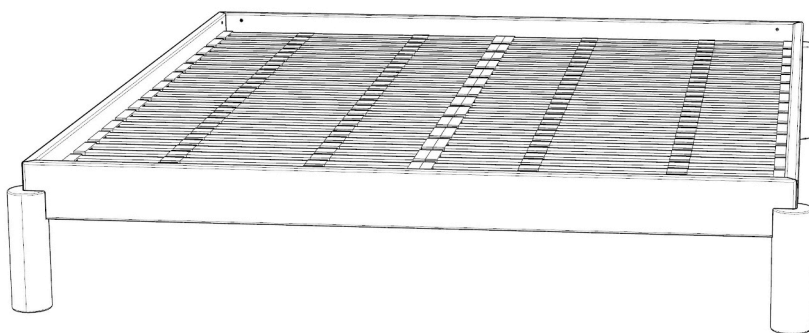











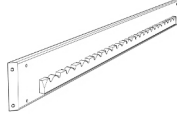

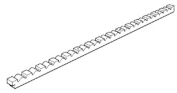
Manual 18° bed

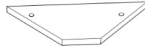

selé

In addition to the steps below, we would like to give you some tips for best results and to prevent damage:

1. Use a rug to prevent scratches.
2. Do not tighten the bolts too hard. Apply some pressure, but do not apply force.
3. Tighten the parts in steps 6 and 7 about 80% first.
4. Next, check that the corners connect properly (top and bottom).
5. If a corner does not fit properly, it is probably because some parts have been tightened more firmly than others.
6. Adjust these parts by loosening and/or tightening them more firmly until the corners fit well and are 100% tightened.
7. Perform step 12 with 2 people (turn over bed).
8. Not satisfied? Feel free to contact us at support@studiosele.com, including your telephone number, and we will call you back as soon as possible.

	2x		16x
	2x		16x
	1x		8x
	8x		26x
	4x		2x
	2x		8x
	30x - 32x*		1x

*depending on the length of the bed

1

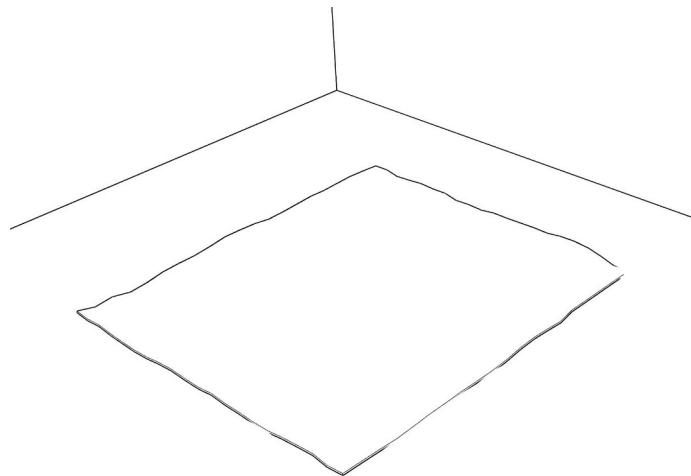

2

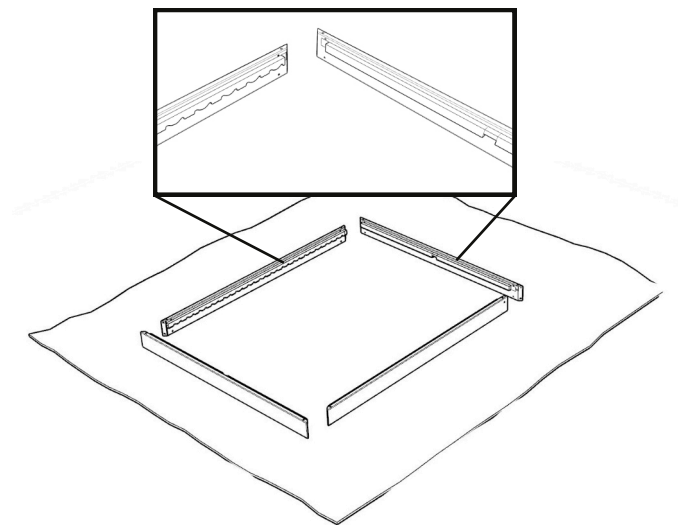

selé

3

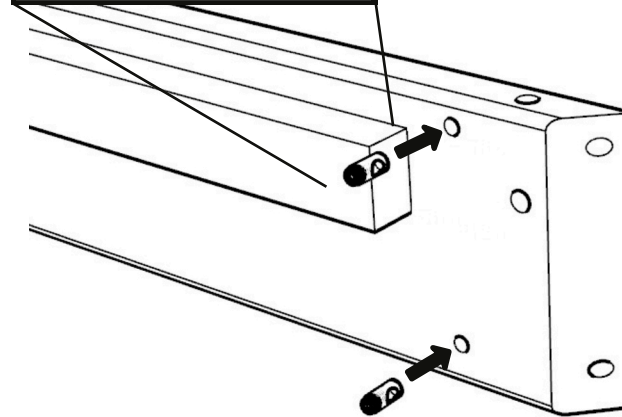
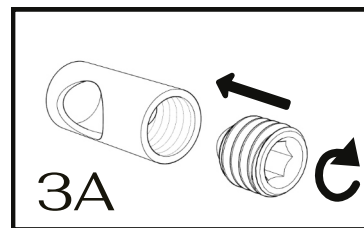
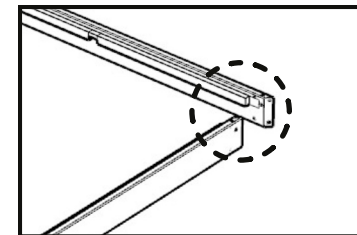
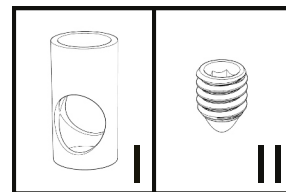

3B

selé

4

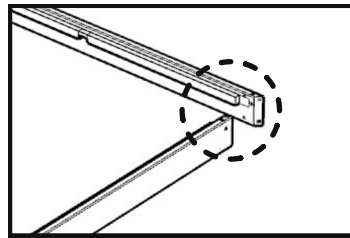
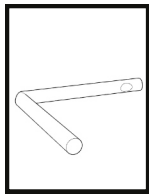

5

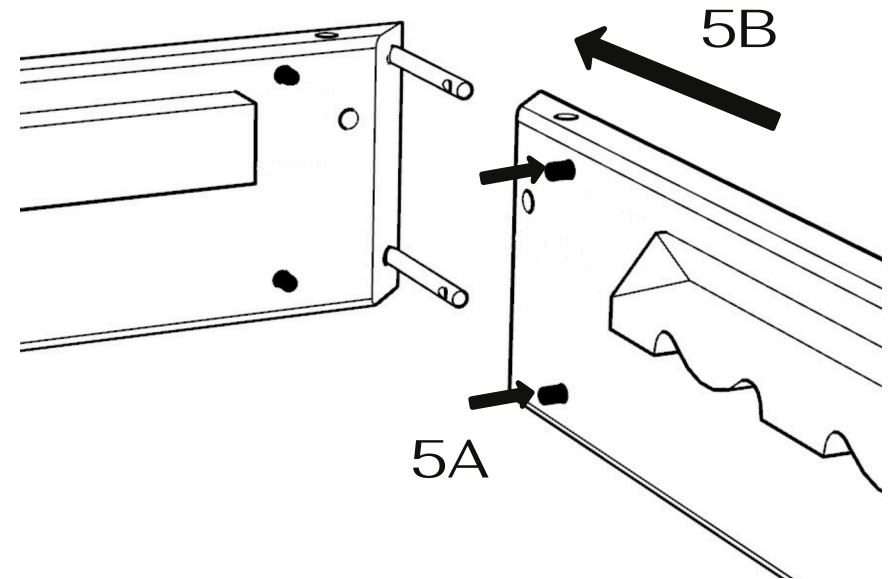
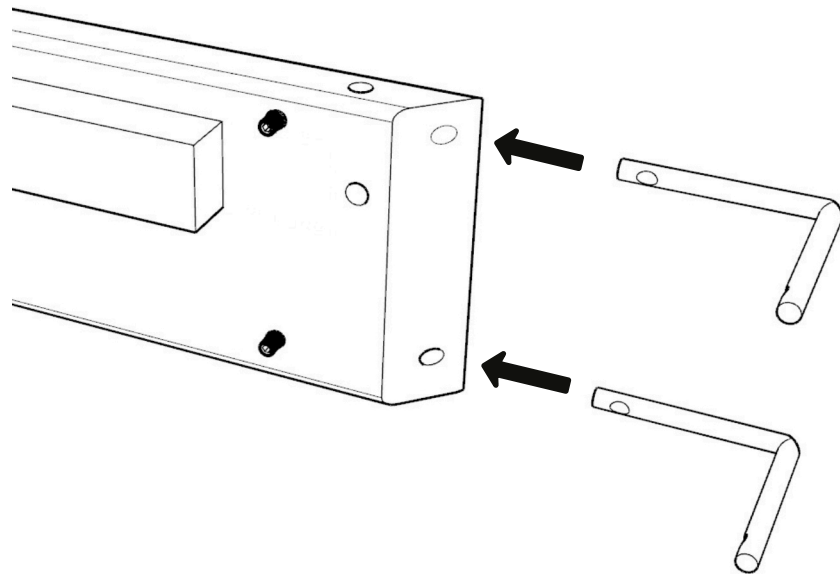
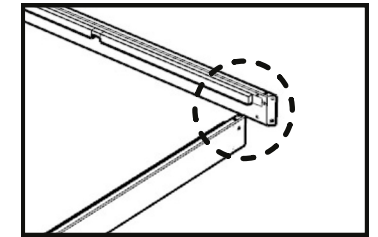
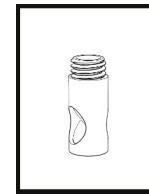

6*

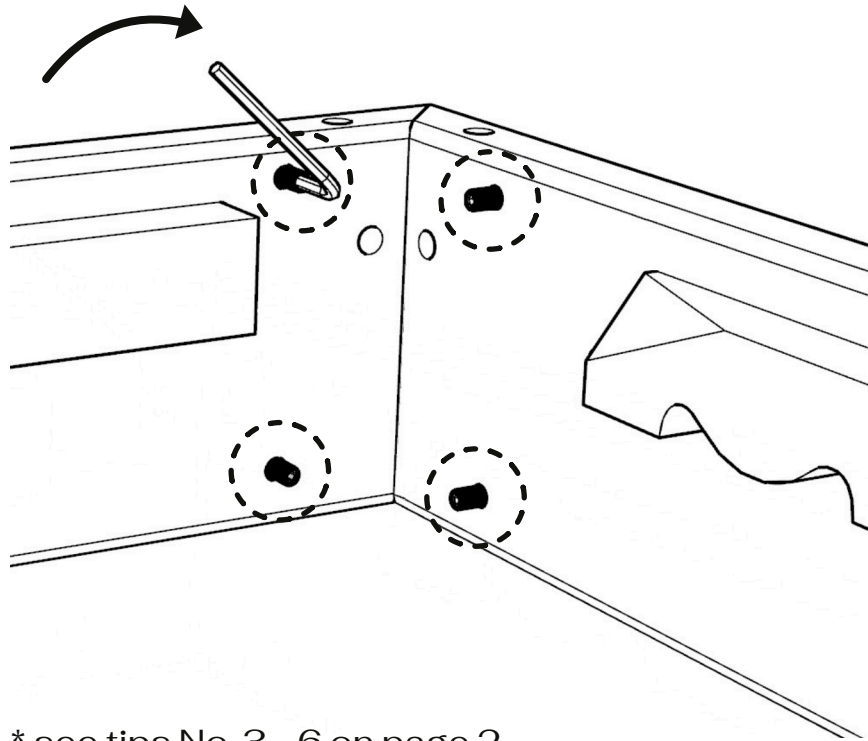
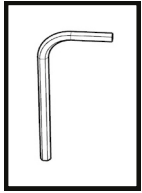

* see tips No. 3 - 6 on page 2.

selé

7*

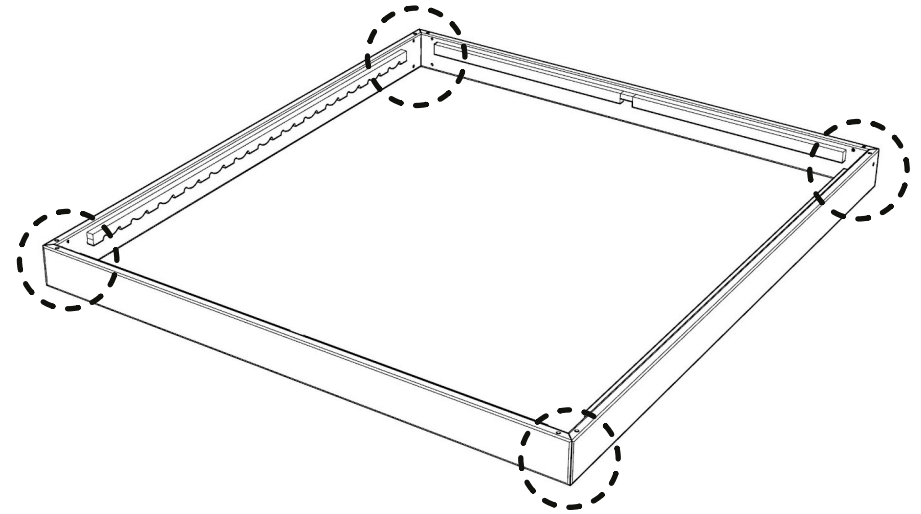
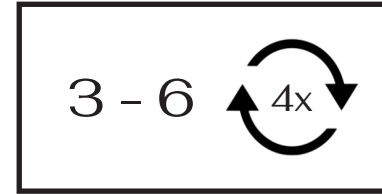

* see tips No. 3 - 6 on page 2.

selé

8

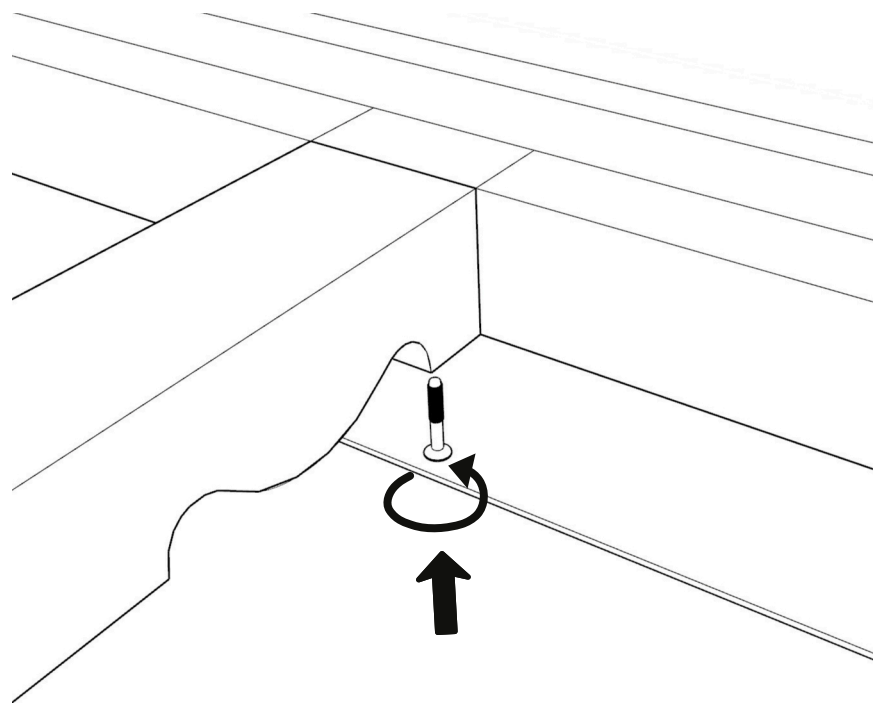
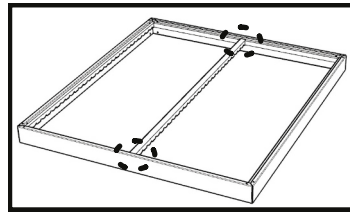
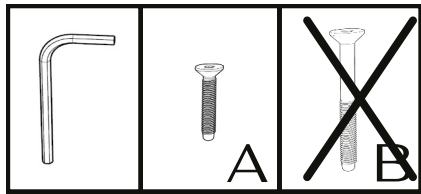

selé

9

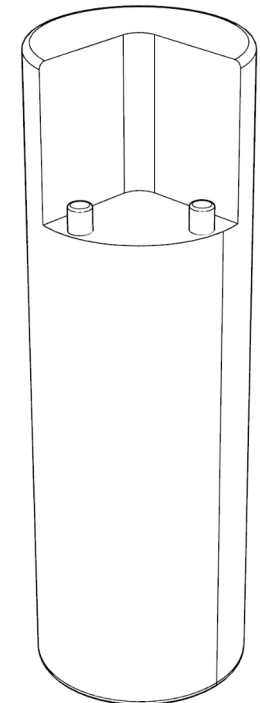
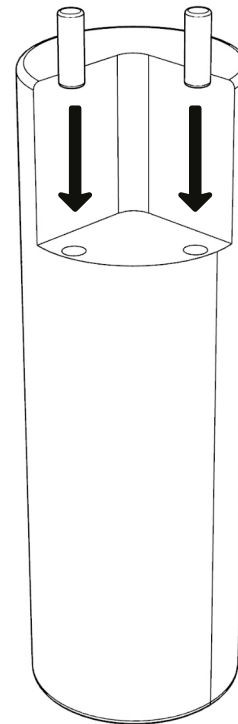
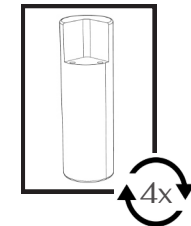
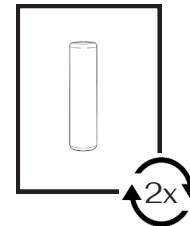

selé

10

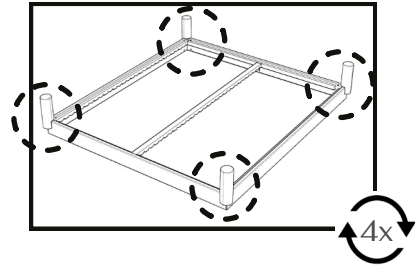
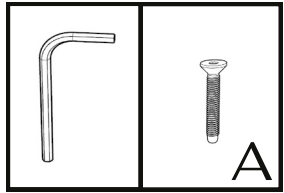

11

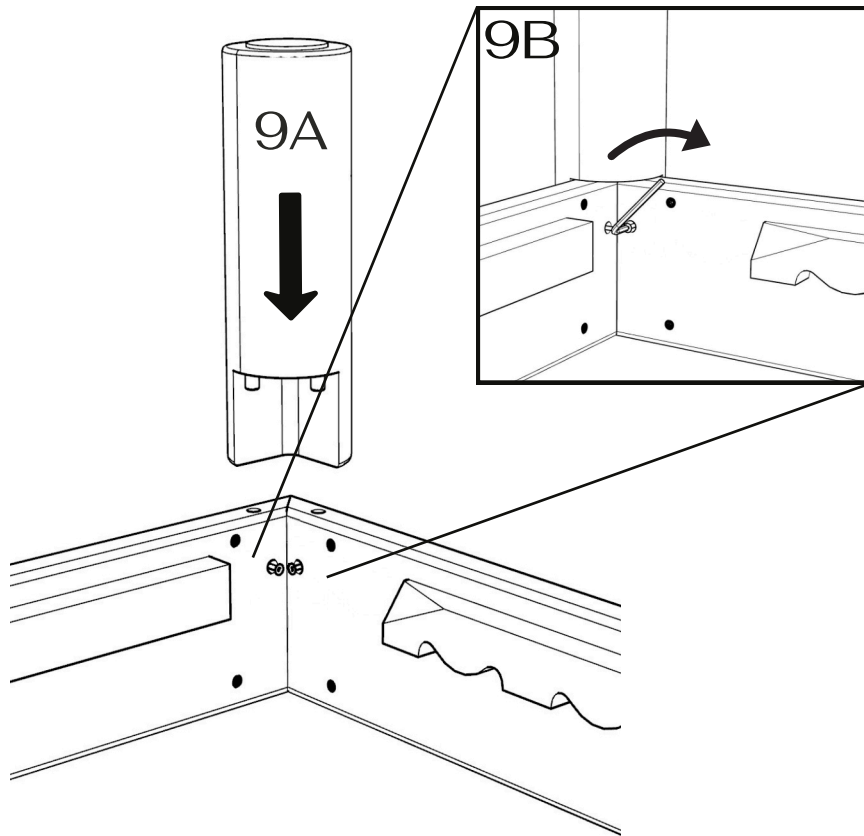
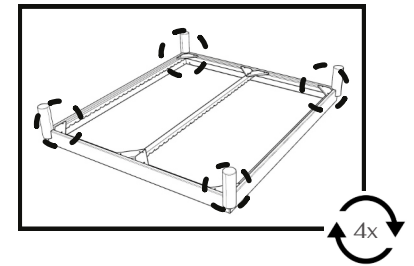
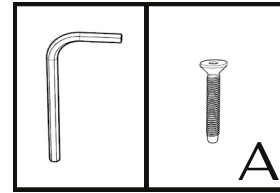

selé

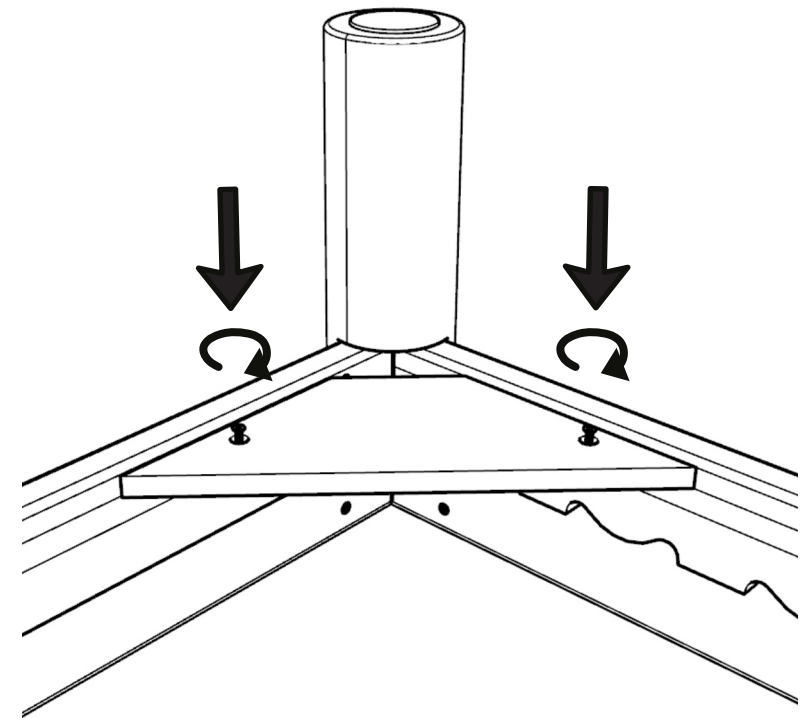

selé

12

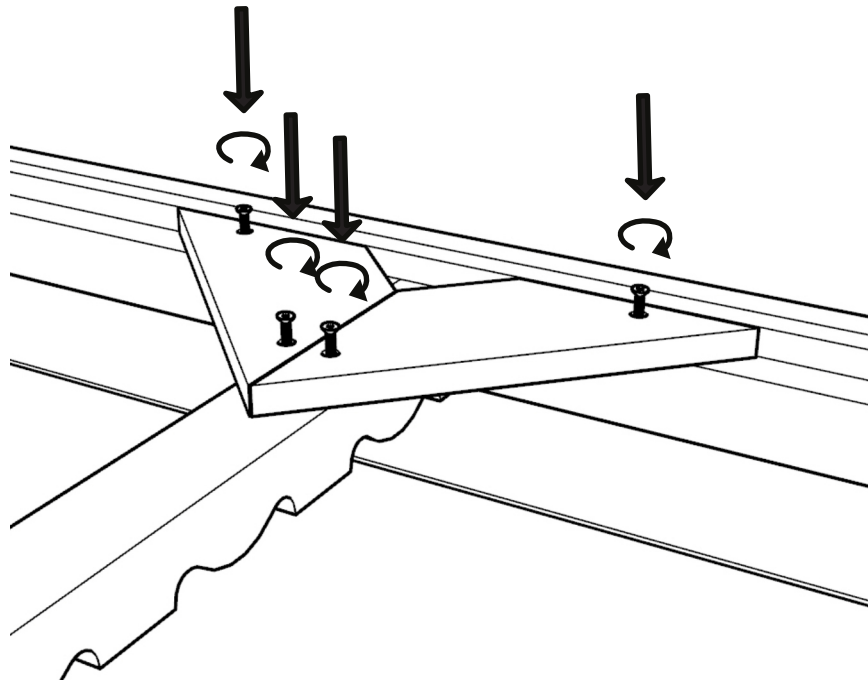
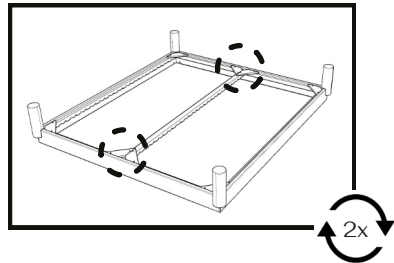
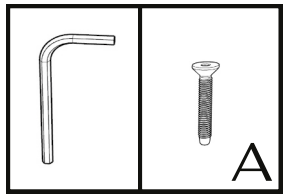

13

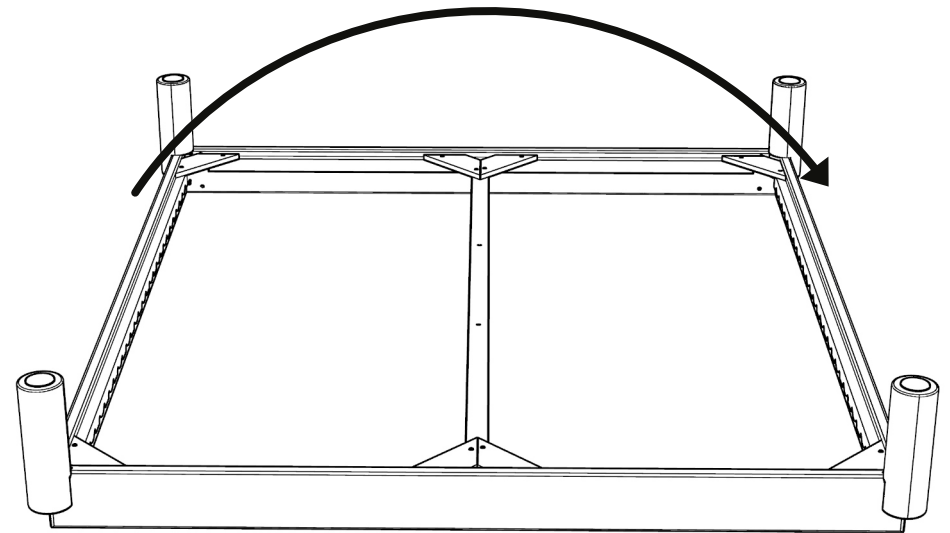

14

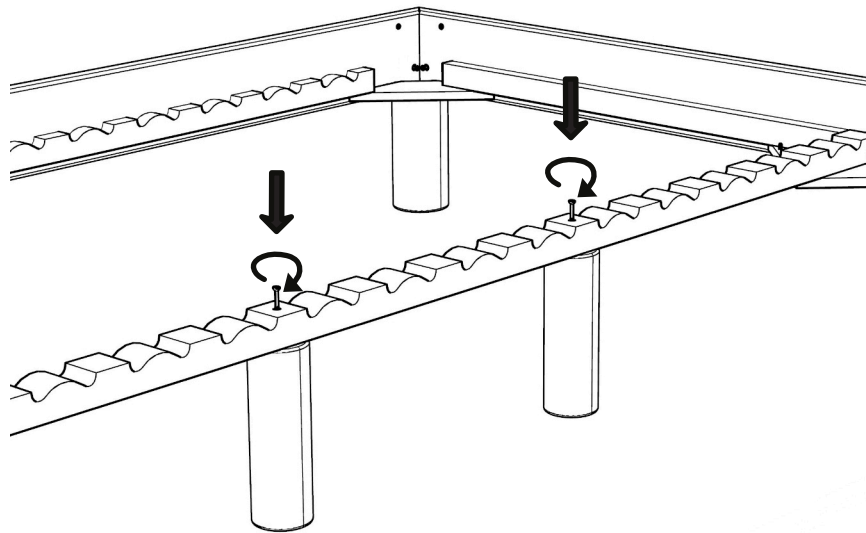
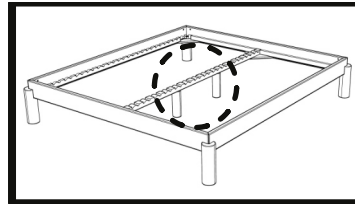
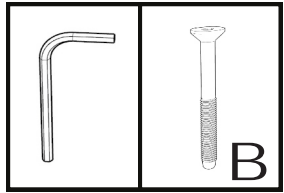

selé

15

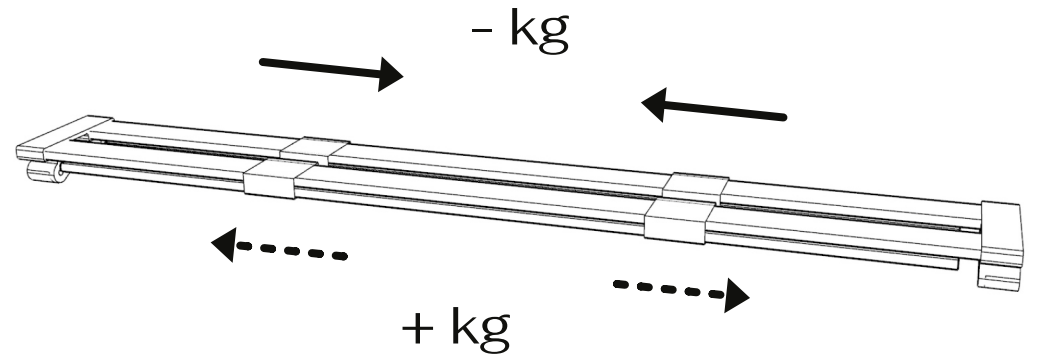

selé

16

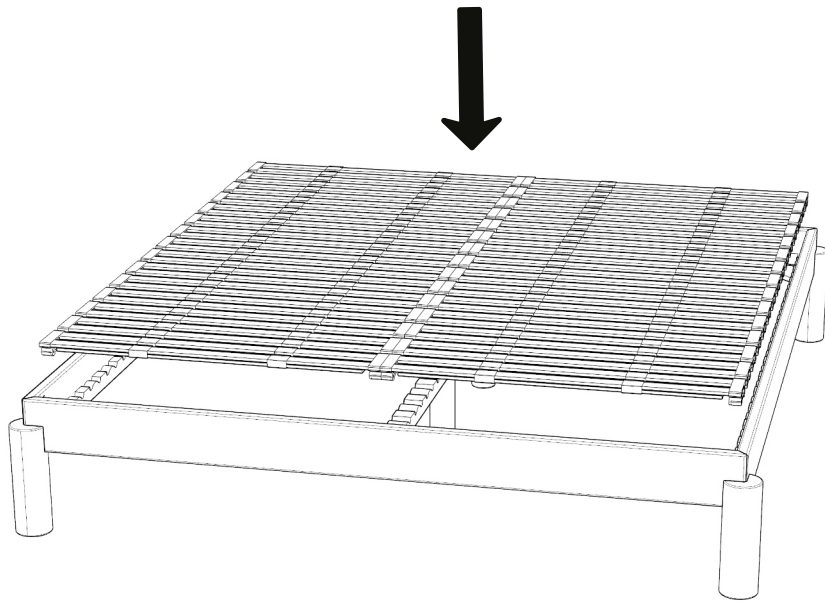

Selé

support@studiosele.com

www.studiosele.com