

TECHNICAL DATA

S286 Oil Level Switch – Capacitance Type

F0ZMULA
INNOVATION IN SENSORS



The **S286** is an active device designed to give an alarm signal if liquid falls below, or rises above, a preset level. It can be specified with a delay to eliminate false alarms due to turbulence.

Containing a factory programmable microprocessor, the switch offers sink to ground or source voltage output. Its small footprint with limited intrusion into the tank means a reduced risk of damage and a wide range of customer specifiable options make it suitable for most applications.

For high accuracy the S286 is ideally mounted horizontally at the point where an alarm or control signal is required. However, the switch can be mounted vertically – contact Fozmula with your application requirements.

SPECIFICATION

Liquid types: Mineral oils, typically used in engines or hydraulic actuators, compatible with brass, PTFE and FVMQ.

Electrical rating

Supply voltage: 9-36 VDC.
Supply current: 7 mA + source output.
Max. load current: 1.0 A (sink) or 20 mA (source).
Alarm delay time: 0 to 25 s rising or falling (factory set).
Connection: 4 way Delphi Packard Metri-Pack 150 series connector.
Power up delay: 0 to 10 s (factory set).
Power up state: 'In Liquid' or 'Out of Liquid' (factory set).
Output type: Sink (open collector) and/or Source (supply voltage).
Output pin: Pin D (sink) or Pin A (source).
Output state: Sink Open / Closed in liquid (factory set).
 Source On / Off in liquid (factory set).

Connections: See diagram below.

Environmental Ratings

Ingress: IP67 (with mating connector fitted).
Max. pressure: 5.0 Bar (72 psi)
Temp. range: -40 °C to +125 °C
Weight: 70 g typical (dependent on thread size)
EMC: ISO13766:2006

Construction

Body: Brass.
Probe: PTFE.
Terminals: Brass, Tin Plated.
Seals: FVMQ.
Connector: PA66 30% Glass Filled Nylon.

Vibration (15.3 Grms)

3 orthogonal planes for 3 hours per plane
 Testing performed in accordance with BSEN 60068-2-64:1993
Drop: 1 m to concrete surface.

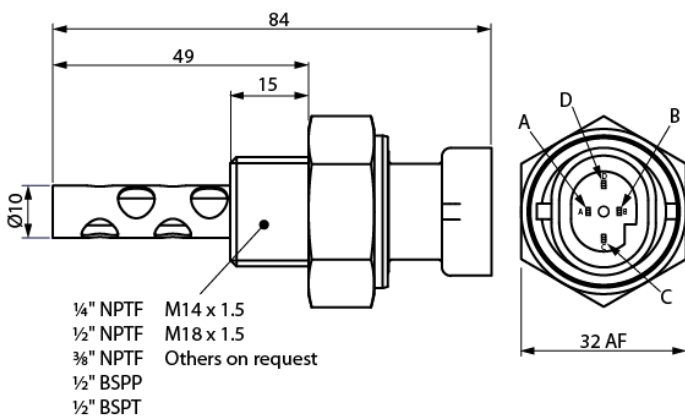

Recommended Installation Tightening Torques:

1/4" NPTF	9 Nm	M14x1.5	10 Nm
3/8" NPTF	11 Nm	M18x1.5	15 Nm
1/2" NPTF	20 Nm		
1/2" BSPP	15 Nm		
1/2" BSPT	20 Nm		

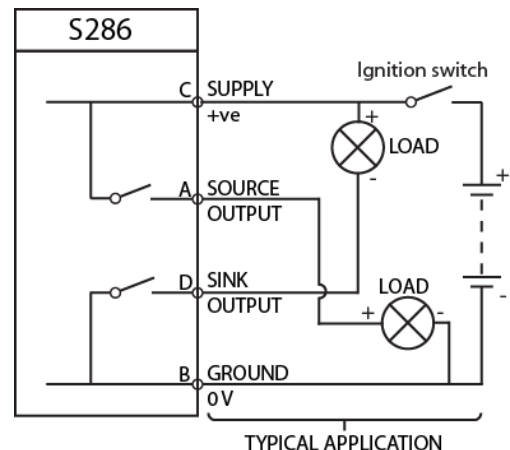

NOTE: IF SINK ONLY OUTPUT IS REQUIRED THEN PIN A IS NOT USED.

Optional accessories

C/K1: Packard Metri-Pack 150 series mating connector kit to suit harness wire cross sectional area of 0.8 to 1.0 mm² and sleeve Ø1.60 to 2.15 mm.

Available From:



GTS Gauges Transmitters Switches Pty Ltd

6 Dayana Close Midvale WA 6056

Ph: 08 9250 4400

Fax: 08 9250 4500

sales@gtsgauges.com.au

www.gtsgauges.com.au