

TECHNICAL DATA

S285 Coolant Level Switch – Capacitance Type

FOZMULA
INNOVATION IN SENSORS



The **S285** is an active device designed to give an alarm signal if liquid falls below, or rises above, a preset level. It can be specified with a delay to eliminate false alarms due to turbulence.

Containing a factory programmable microprocessor, the switch offers sink to ground or source voltage output. Its small footprint with limited intrusion into the tank means a reduced risk of damage and a wide range of customer specifiable options make it suitable for most applications.

The switch is designed to operate in both earthed metal and isolated plastic tanks. For high accuracy the S285 is ideally mounted horizontally at the point where an alarm or control signal is required. However, the switch can be mounted vertically – contact Fozmula with your application requirements.

SPECIFICATION

Liquid types:

Water based liquids, such as coolant or washer fluid, compatible with brass, PTFE, EPDM and FVMQ.

Electrical rating

Supply voltage:

9-36 VDC.

Supply current:

7 mA + source output.

Max. load current:

1.0 A (sink) or 20 mA (source).

Alarm delay time:

0 to 25 s rising or falling (factory set).

Connection:

4 way Delphi Packard Metri-Pack 150 series connector.

Power up delay:

0 to 10 s (factory set).

Power up state:

'In Liquid' or 'Out of Liquid' (factory set).

Output type:

Sink (open collector) and/or Source (supply voltage).

Output pin:

Pin D (sink) or Pin A (source).

Output state:

Sink Open / Closed in liquid (factory set).

Source On / Off in liquid (factory set).

Connections:

See diagram below.

Environmental Ratings

Ingress:

IP67 (with mating connector fitted).

Max. pressure:

5.0 Bar (72 psi)

Temp. range:

-40 °C to +125 °C

Weight:

70 g typical (dependent on thread size)

EMC:

ISO13766:2006

Construction

Body:

Brass.

Probe:

PTFE.

Terminals:

Brass, Tin Plated.

Seals:

EPDM & FVMQ.

Connector:

PA66 30% Glass Filled Nylon.

Thread sealant:

Vibra-Seal 516 (taper thread variants only).

Vibration (15.3 Grms)

3 orthogonal planes for 3 hours per plane

Testing performed in accordance with BSEN 60068-2-64:1993

Drop:

1 m to concrete surface.

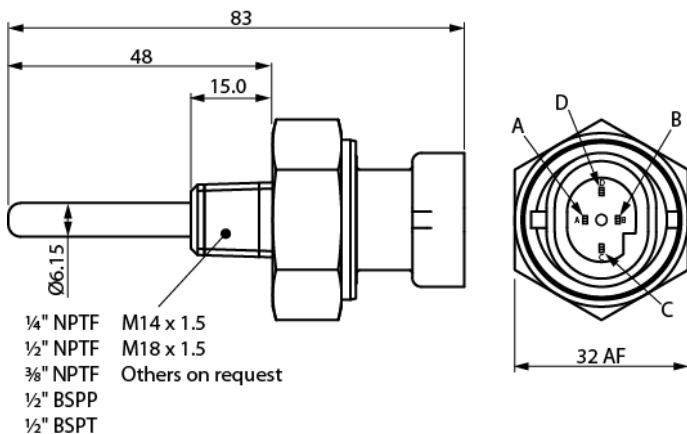

Recommended Installation Tightening Torques:

1/4" NPTF	9 Nm	M14x1.5	10 Nm
3/8" NPTF	11 Nm	M18x1.5	15 Nm
1/2" NPTF	20 Nm		
1/2" BSPP	15 Nm		
1/2" BSPT	20 Nm		

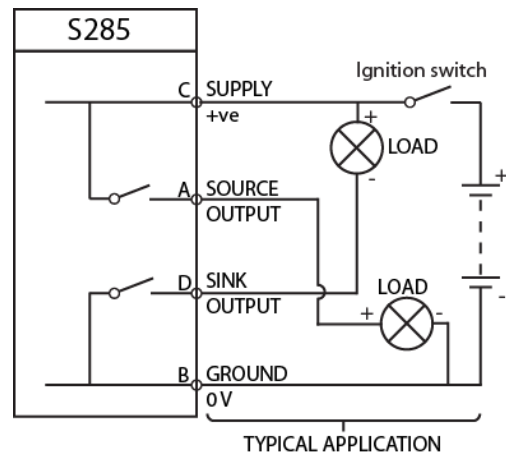

NOTE: IF SINK ONLY OUTPUT IS REQUIRED THEN PIN A IS NOT USED.

Optional accessories

C/K1: Packard Metri-Pack 150 series mating connector kit to suit harness wire cross sectional area of 0.8 to 1.0 mm² and sleeve Ø1.60 to 2.15 mm.

Available From:



GTS Gauges Transmitters Switches Pty Ltd

6 Dayana Close Midvale WA 6056

Ph: 08 9250 4400

Fax: 08 9250 4500

sales@gtsgauges.com.au

www.gtsgauges.com.au