

INSTALLATION INSTRUCTIONS

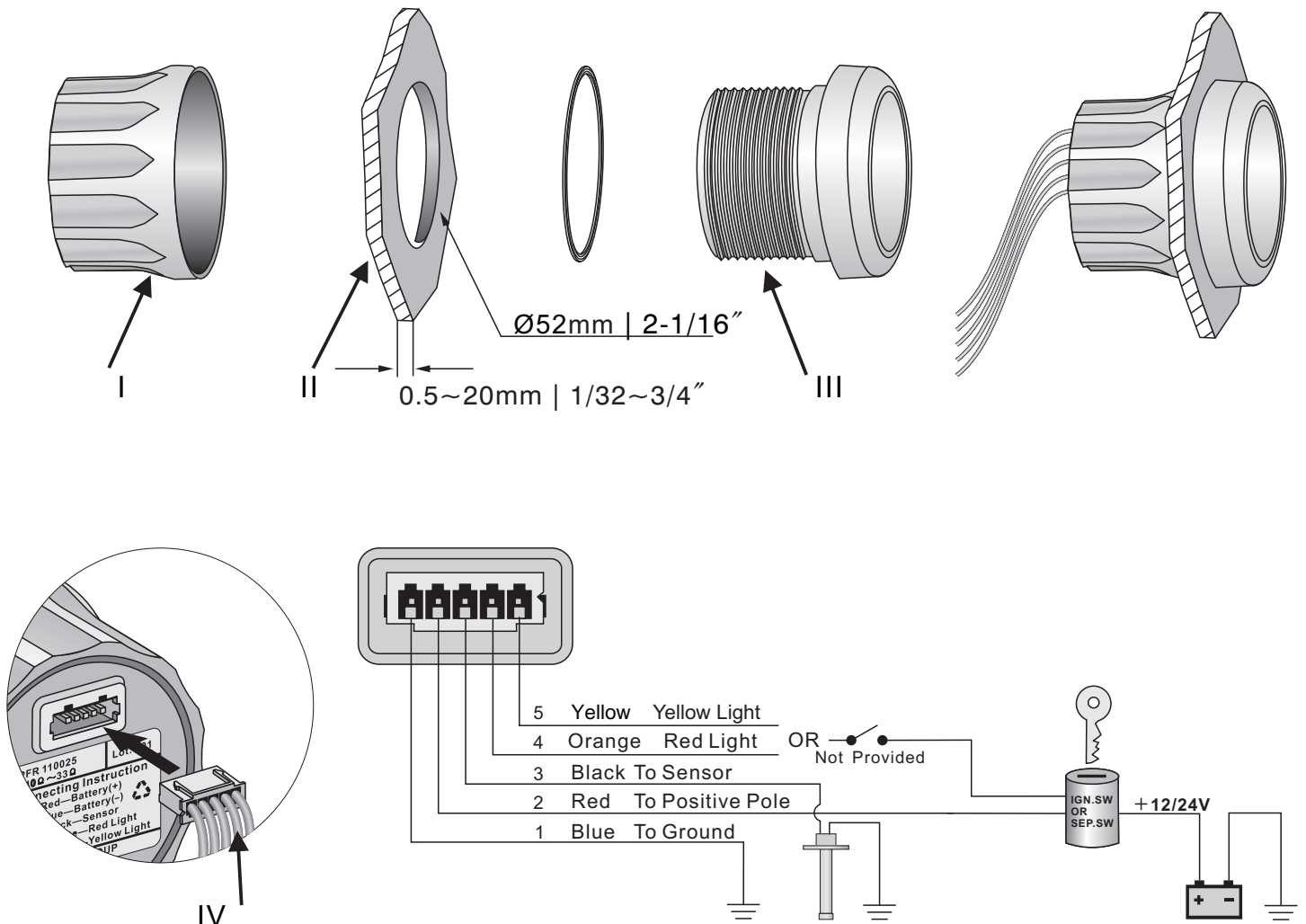

INSTALLATION STEPS

1. Cut a 52mm (2 1/16") diameter panel hole (II). You will need a minimum clearance of 55mm (2 3/16") behind the panel to fit the gauge.
2. Remove fastening ring (I). There is an alignment tab on the gauge body (III), place the gauge in the panel hole and mark the position of this tab to correctly align the gauge.
3. Insert gauge through panel from the front, fit and tighten fastening ring (I) from the rear.
4. Connect wires according to wiring instruction. Note the use of dropping resistors for a 24V circuit. Select either Orange or Yellow wires for backlighting. Wire colour corresponds with backlight colour.
5. Insert wire harness (IV) into port at the back of the gauge.
6. Please note, if the gauge is a voltmeter, there is no black wire or resistors in the kit.

GTS Gauges Transmitters Switches Pty Ltd

6 Dayana Close, Midvale, WA 6056

08 9350 4400

sales@gtsgauges.com.au

www.gtsgauges.com.au

0673-03