

Mechanical Gauge - MGCS Series

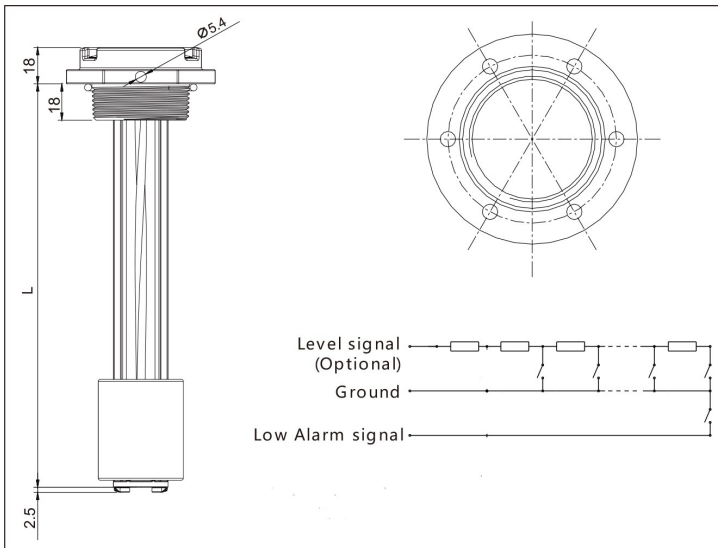

- The mechanical gauge integrates the function of level measuring and level display.
- This gauge is well suited to fuel tanks of generators and engines. It is also suited to water tanks.
- **Functions:** Indication of liquid level, low level alarm, and 0 –190 Ohms output.
- **Environment:** Can be used in static liquid and dynamic liquid of generators, boat, etc...
- **Assembly:** Thread 1-1/2" BSPT.
- **Advantage:** Instrument surface is isolation type, semicircle casing protection, better able to withstand shocks without damage.

MGCS Series

Length	Main Body thread
300	1-1/2" BSPT
400	1-1/2" BSPT
500	1-1/2" BSPT
600	1-1/2" BSPT
700	1-1/2" BSPT
800	1-1/2" BSPT
900	1-1/2" BSPT
1000	1-1/2" BSPT



KUS CPFR-BB-0-190



KUS CPWR-BB-0-190



GTS GAUGES TRANSMITTERS SWITCHES

Ph: (08) 9250 4400 ▼ sales@gtsgauges.com.au ▼ www.gtsgauges.com.au