

GTS 50 - RE



DESCRIPTION

1. FOR ITEM #202-20E
2. AISI304 STAINLESS STEEL HOUSING
3. AISI304 STAINLESS STEEL CRIMPED RING
4. POLYCARBONATE LENS
5. ALUMINUM DIAL
6. ALUMINUM POINTER, BLACK FINISHED
7. COPPER ALLOY MOVEMENT
- 8-1. PHOSPHOR BRONZE BOURDON TUBE
- 8-2. BOURDON TUBE IN C-FORM(< 100bar/1500psi)
- 8-3. BOURDON TUBE IN HELICAL-FORM(> 100bar/1500psi)
- 9-1. CONNECTOR WITH M4 RESTRICTOR
- 9-2. CENTER BACK CONNECTION
10. WELDING : TIN COPPER ALLOY (< 100bar/1500psi)
SILVER ALLOY (>100bar/1500psi)
11. WITH +/-2.5% ACCURACY

APPEARANCE

1. Housing/Ring with no burr, mix-color, scratch, sand holes, deform, and any damages.
2. Lens with no scratch, dent, protrusion, and fuzzy.
3. Surface of pointer with no scratch, deform; and the color of the pointer needs to be correct, no mix-color.
4. Liquid oil needs to be purity and no color changing.
5. Remove the oil plog when the gauge is installed.
6. Use spanner to install the gauge.
7. No oil leak.
8. Tapping the oil-free pressure gauge for 3~5 times, this should not have any unusual noise appear.
9. No extra materials or foreign bodies (Example- Label sticker, protect membrane...etc.).
10. No miss packing (Example- plugs, screws, screw protectors...etc)

INSPECTION REQUIREMENTS PRESSURE INSPECTION

1. Pointer at zero: After tapping the housing, pointer should lean against stop pin; if there is no pin, then the pointer should stop at the zero line.
2. During the application of the gauge, the pointer needs to stay steady without stagnation.
3. All pressure inspection points need to fit the standard tolerance.
4. Working pressure: Max 75% of full scale value.
5. Over Pressure Limit: Max 30% of the full scale value (0~60 BAR)
Over Pressure Limit: Max 25% of the full scale value (60~100 BAR)
Over Pressure Limit: Max 15% of the full scale value (over 100 BAR)
Bourdon tube
6. 2000 times(a pressure fluctuating from 30% to 60% of the maximum scale value).
after weiling Cyclic pressure test:

CONNECTOR & POINTER

1. No oxidize stain, damage, crack or deform appear on the surface of the connector.
2. The end of the thread needs to be parallel with the thread ring gauge.
3. The tensil of the pointer can support upto 2 kg

INSPECTION REQUIREMENTS

The Parts materials

1. Housing materials:AISI304 Stainless Steel
Ring materials : AISI304 Stainless Steel
2. Connector : Copper Alloy(HPb59-1,
Cu 57%~59%,Pb <2.5%),**Strictly use no recycle copper material**
3. Bourdon Tube : Phosphor Bronze
4. Housing Fixed Screws : AISI304 Stainless Steel
5. The above parts needs to have material certification or
Outside Inspection with the inspection report

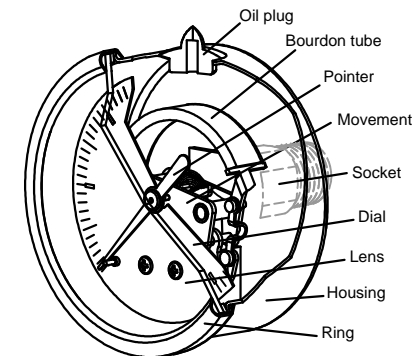
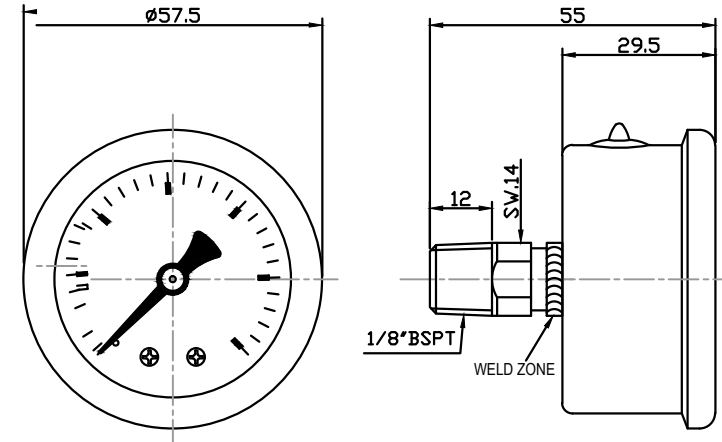

3D Schematic diagram



GTS GAUGES TRANSMITTERS SWITCHES

Ph: (08) 9250 4400 ▼ sales@gtsgauges.com.au ▼ www.gtsgauges.com.au