

may include a rearward periphery in alignment with the rearward edges.

23 Claims, 6 Drawing Sheets

(58) **Field of Classification Search**

CPC A41G 3/0058; A41G 5/00; A41G 5/0053; A41G 5/0093; A42B 1/008; A42B 1/225; A45D 8/36; A45D 8/40
 USPC 132/53, 54, 55, 56, 201; 2/171, 174, 2/209.5; D28/41, 92, 93
 See application file for complete search history.

(56) **References Cited**

U.S. PATENT DOCUMENTS

1,634,190 A * 6/1927 Hepner A41G 3/00
 132/53
 1,740,764 A * 12/1929 Bong A41G 3/00
 132/201
 2,233,100 A * 2/1941 Jevnikar A41G 3/00
 132/53
 2,700,977 A * 2/1955 Neerup A45D 8/40
 132/273
 2,736,325 A * 2/1956 Dvorzszak A41G 5/0006
 132/53
 3,474,798 A 10/1969 Tillotson
 3,788,332 A 1/1974 Abbott et al.
 4,155,370 A 5/1979 Nemoto
 4,492,242 A * 1/1985 Dalton A41G 5/0093
 132/53
 D333,013 S 2/1993 Scianna
 5,265,280 A * 11/1993 Walsh A41D 13/11
 128/206.12
 5,657,774 A * 8/1997 Niese A41G 5/0093
 132/105
 5,806,535 A * 9/1998 Becker A41G 3/0016
 132/53
 6,352,079 B1 3/2002 Bate
 7,537,014 B1 5/2009 Yoo
 D644,379 S 8/2011 Vanesse
 8,261,753 B2 9/2012 Newman et al.
 8,266,721 B1 * 9/2012 Mueller A42B 1/041
 2/171
 D669,633 S 10/2012 Hedgren
 D712,094 S 8/2014 Branson
 9,027,568 B2 5/2015 Lee
 9,107,460 B1 8/2015 Synn et al.
 9,138,024 B1 * 9/2015 Solomon A41G 5/0073
 9,486,023 B1 * 11/2016 Kim A41G 3/00
 D879,382 S * 3/2020 Ning D28/93
 2003/0029467 A1 * 2/2003 Katon A41G 3/0033
 132/53
 2003/0131861 A1 7/2003 Prestia
 2004/0149299 A1 8/2004 Kim
 2006/0174905 A1 * 8/2006 Bias A41G 5/0093
 132/53
 2007/0283975 A1 * 12/2007 Ma A41G 5/0093
 132/53

2008/0178902 A1 * 7/2008 Moeszinger A45D 8/36
 132/273
 2011/0023902 A1 * 2/2011 Cho A41G 3/005
 132/53
 2011/0073122 A1 * 3/2011 Shigematsu A41G 3/005
 132/54
 2011/0186065 A1 * 8/2011 Inoue A41G 5/00
 132/54
 2011/0303234 A1 * 12/2011 Xiangyong A41G 3/0075
 132/54
 2012/0222692 A1 * 9/2012 Ray A41G 5/0093
 132/53
 2013/0019889 A1 * 1/2013 Palmer-Rogers A41G 3/0041
 132/201
 2014/0020703 A1 * 1/2014 Tiram A41D 20/00
 132/201
 2014/0202481 A1 7/2014 Sato et al.
 2014/0251362 A1 * 9/2014 Lee A41G 3/00
 132/201
 2014/0326267 A1 * 11/2014 Peterson A41G 5/004
 132/201
 2015/0013708 A1 1/2015 Chamberlain
 2015/0128979 A1 5/2015 Suh
 2015/0327609 A1 11/2015 Suh
 2017/0095026 A1 4/2017 Chung
 2018/0007988 A1 1/2018 Kim et al.
 2018/0055122 A1 * 3/2018 Kim A41G 3/0033
 2019/0104793 A1 * 4/2019 Young A41G 5/004

FOREIGN PATENT DOCUMENTS

GB 191401976 A * 5/1914 A41G 3/00
 GB 1388300 3/1975
 GB 2537182 A * 12/2016 A41G 5/00
 WO WO-2015064870 A1 * 5/2015 A41G 3/005

OTHER PUBLICATIONS

JP Design Registration No. D1379926, entitled “Retention band which is something which”; Publication date Feb. 15, 2010; Registration owner: Brain Ltd.
 JP Design Registration No. D1391781, entitled “Hair Band”; Publication date Jul. 5, 2010; Registration owner: Sante Professional Corporation.
 JP Design Registration No. D1586936, entitled “Head band”; Publication date Oct. 2, 2017; Registration owner: Takayuki Onuma.
 KR Design Registration No. 3002983000000, entitled “Cold Pack Pack Band”; Publication date May 17, 2002; Applicant: Lee Seong Hoon.
 KR Design Registration No. 3005060070000, entitled “Perfume Blocking Hair Band”; Publication date Sep. 17, 2008; Applicant: Jeong, Myoung-Seok.
 KR Design Registration No. 3006686140001, entitled “Hair Band”; Publication date Nov. 22, 2012; Applicant: J&J USA Co. Ltd.
 Title: “Discover ideas about U part wig”; URL: <https://www.pinterest.com/pin/630644754049080146/>; Published date: Feb. 2019.
 Title: “Milano Collection Original WiGrip Wig Comfort Band”; URL: <http://www.mewigs.com/wigrip.html>; Published date: Sep. 22, 2017.

* cited by examiner

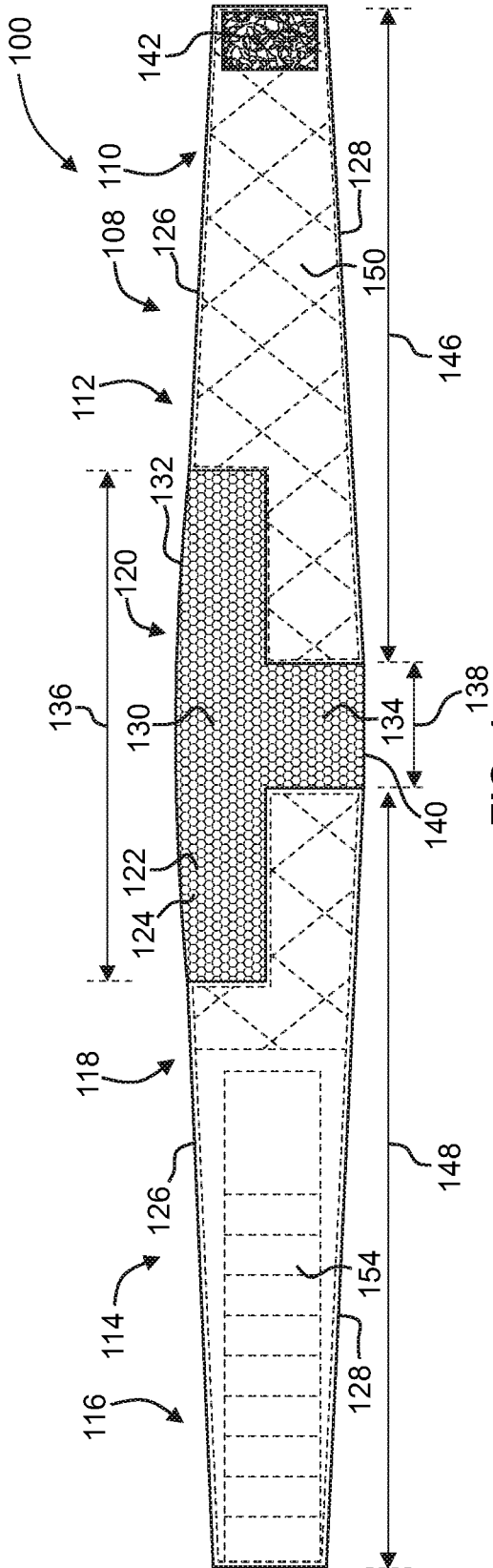

FIG. 1

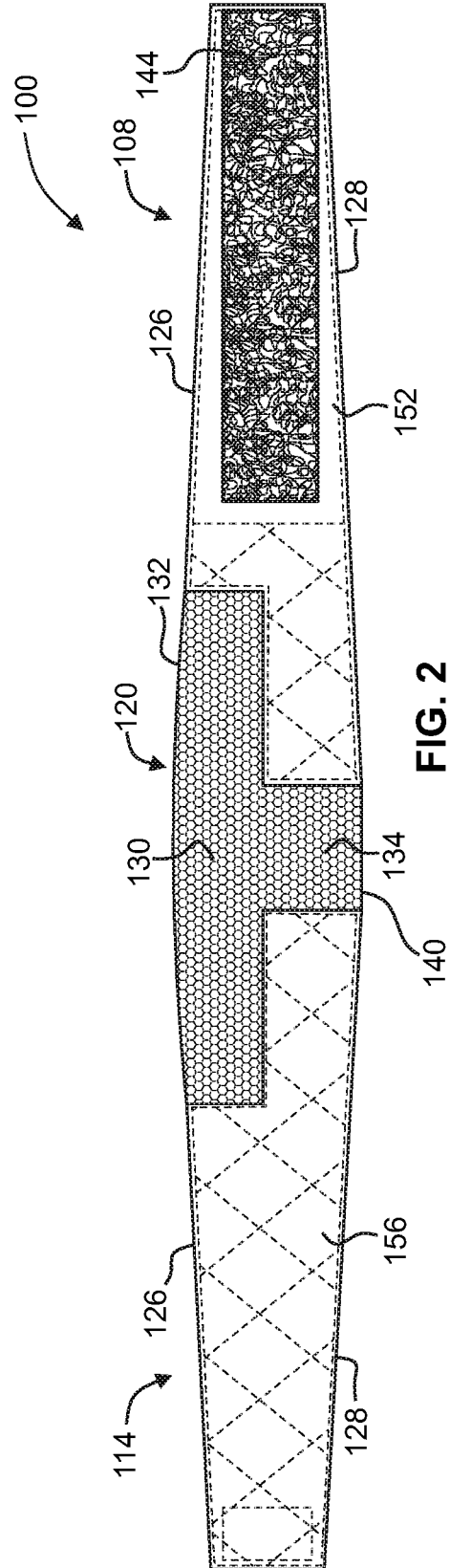

FIG. 2

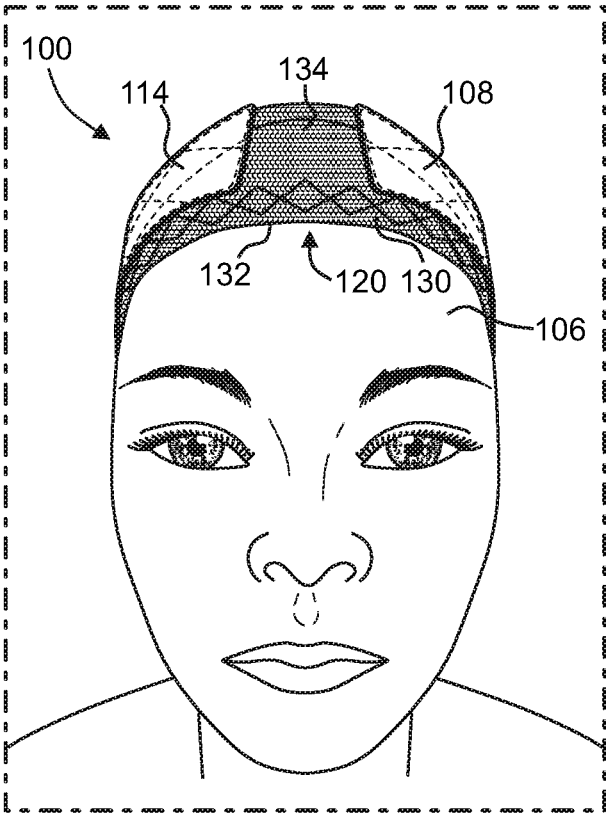

FIG. 3

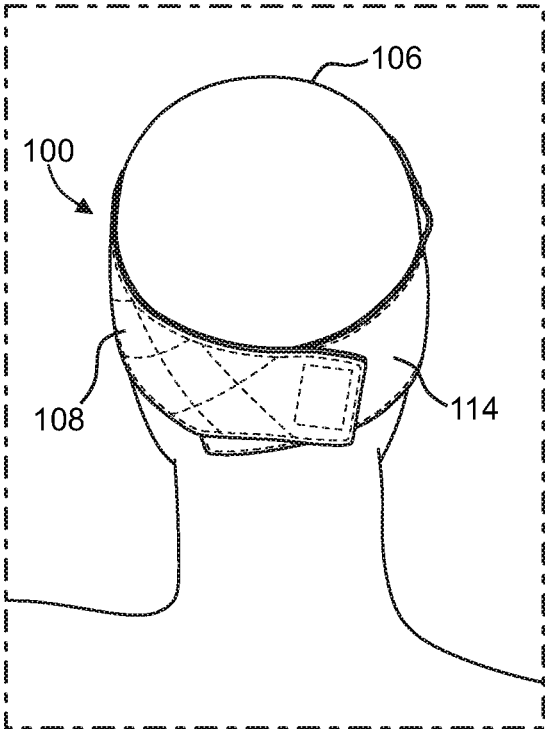

FIG. 4

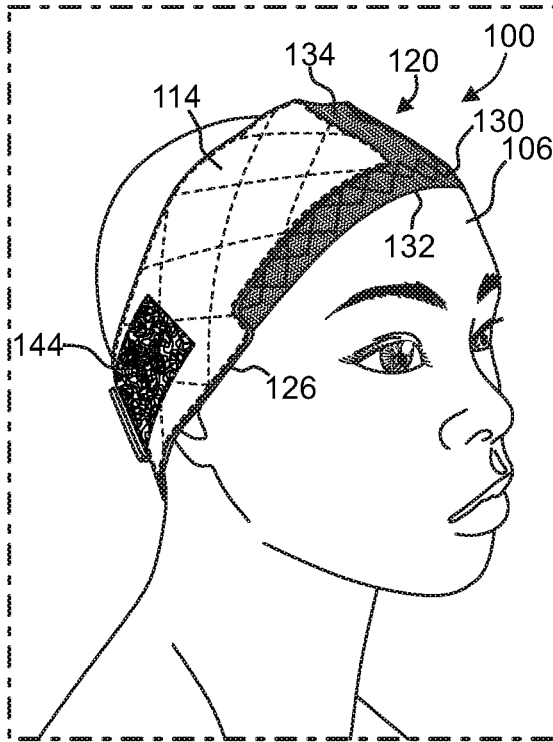

FIG. 5

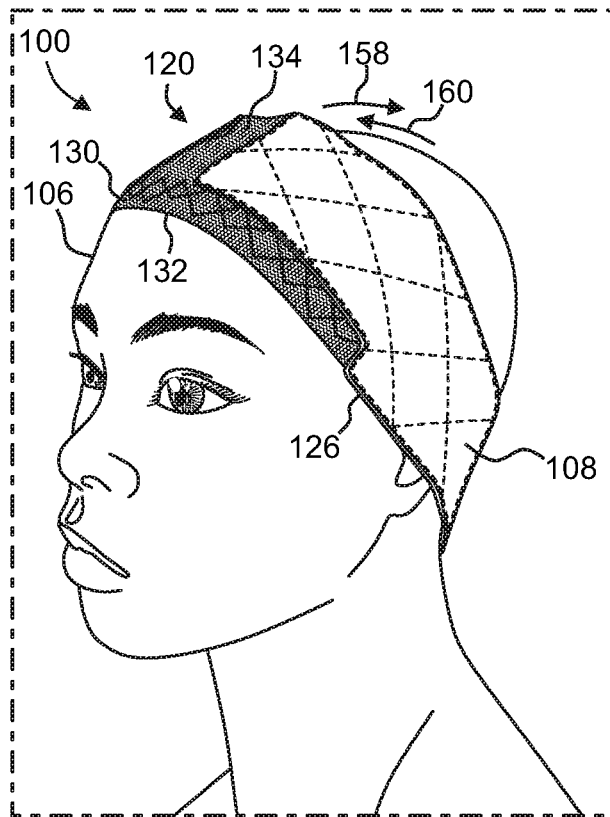

FIG. 6

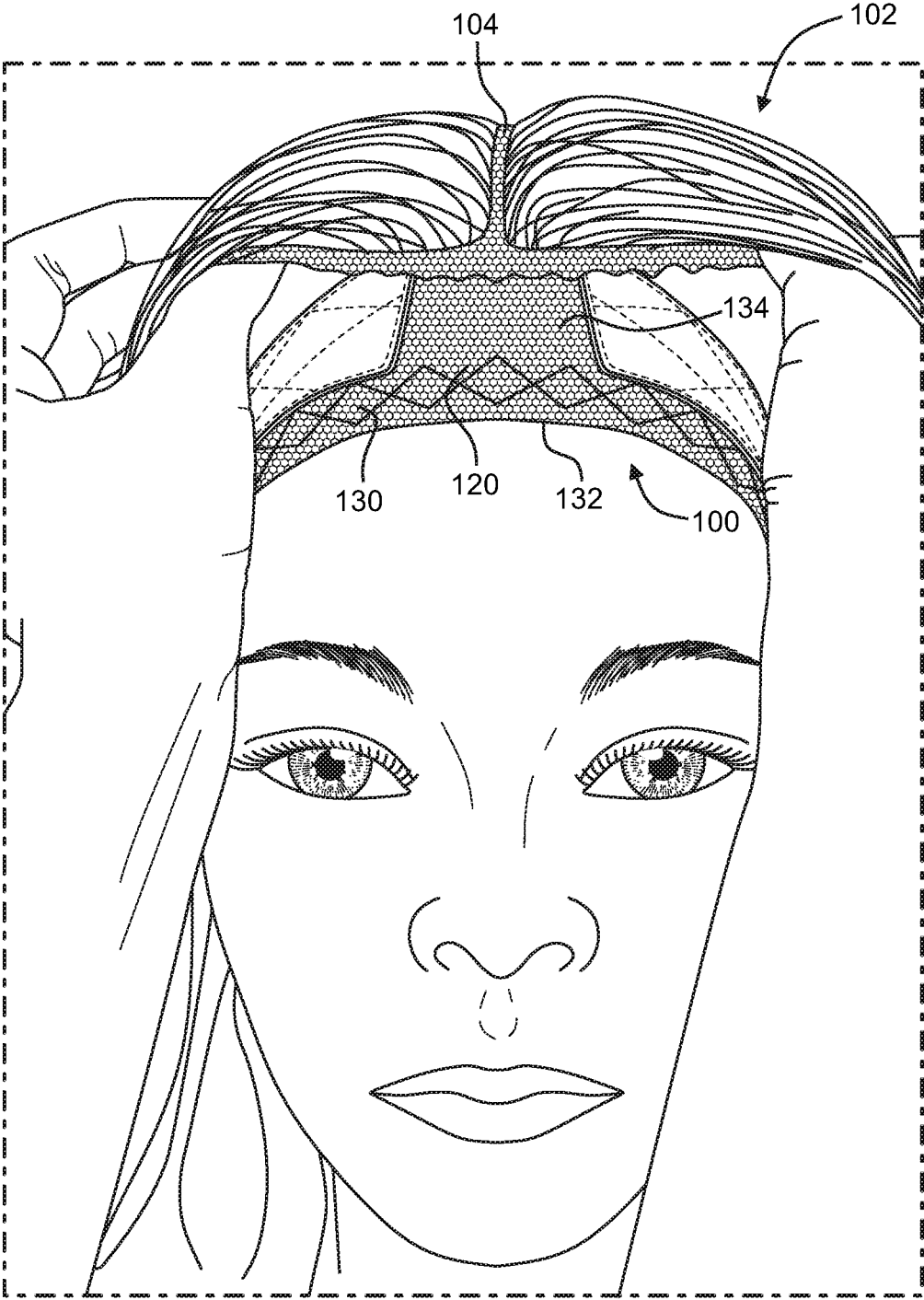

FIG. 7

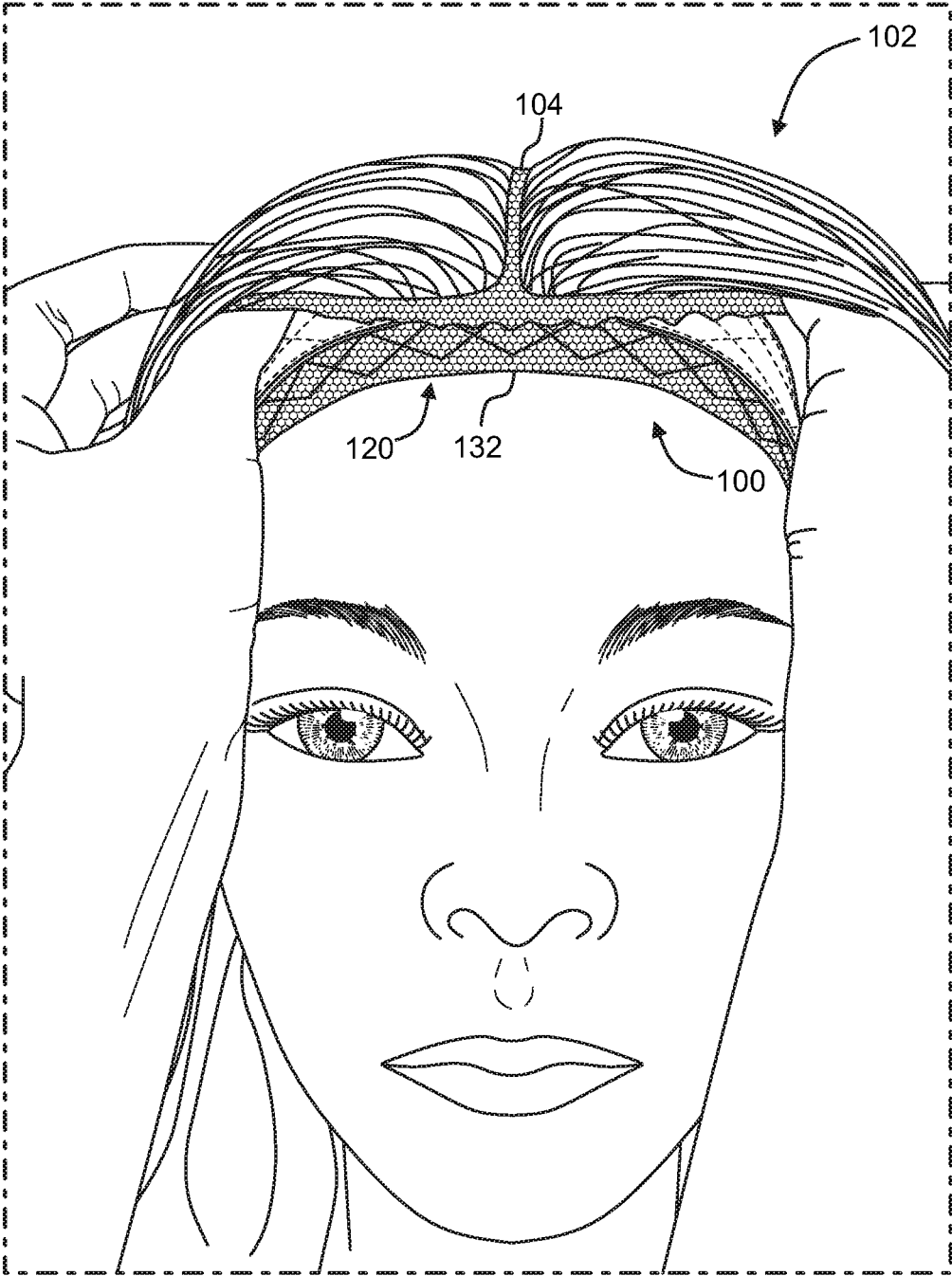

FIG. 8

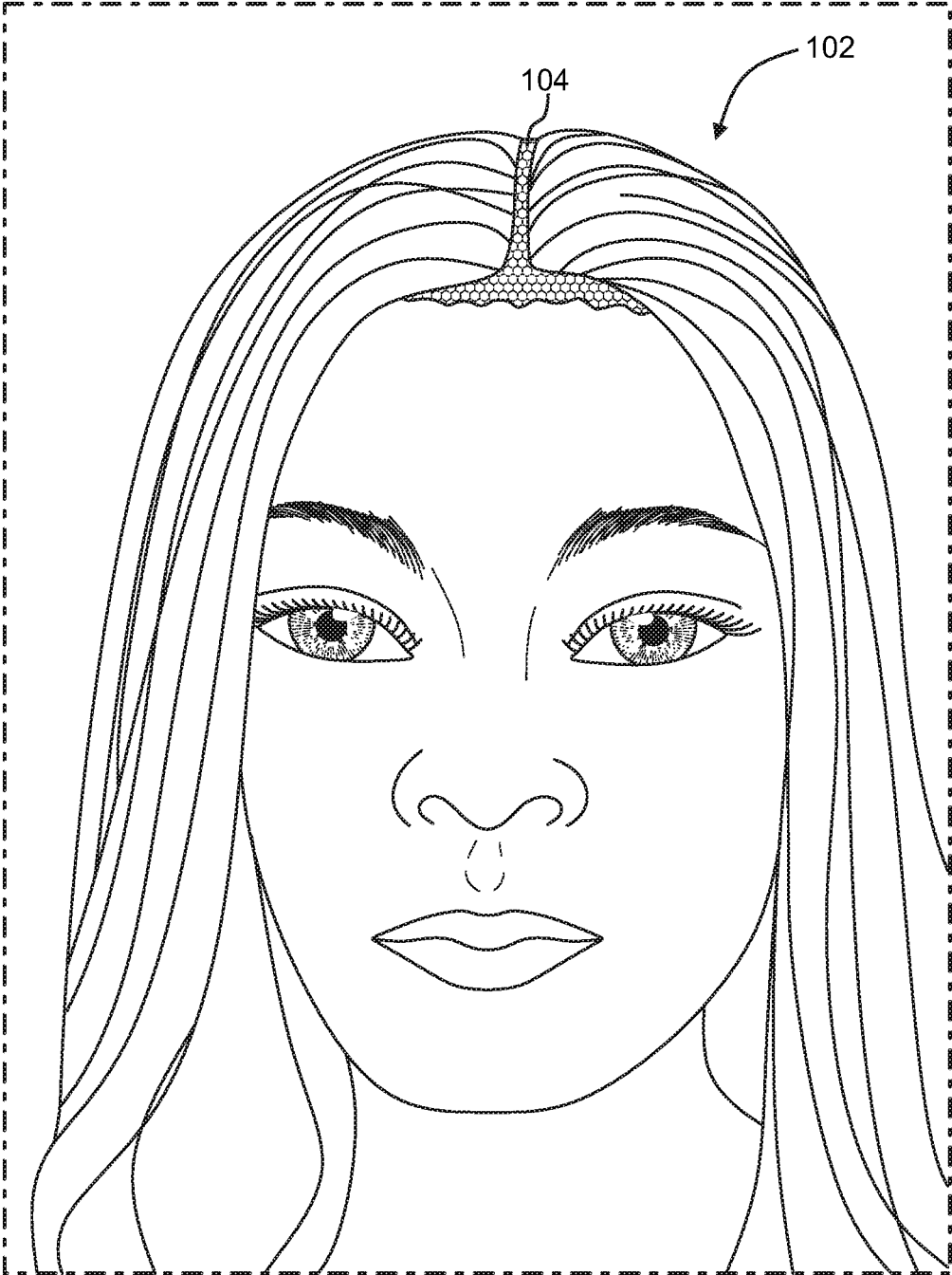

FIG. 9

WIG GRIP APPARATUS

TECHNICAL FIELD

The disclosure herein relates generally to wigs and hairpieces. More particularly, the present disclosure relates to devices for facilitating the stable attachment of wigs to the head of a wearer.

BACKGROUND

The lace foundation portions of conventional wigs and frontal hairpieces tend to be transparent, and therefore need to lay very flat on the scalp in order to optimally achieve a natural appearance. Consequently, when a conventional wig gripping device is worn between the wearer's scalp and the conventional wig, that conventional device is frequently visible through the hairpiece foundation to the eye of an outside observer. What is needed is a wig grip device that helps removably secure a lace-foundation wig or frontal hairpiece to the head of a wearer, while preserving the appearance that the hair stands of the headpiece originate from the underlying scalp at the location of the front hairline and hair part of the hairpiece.

SUMMARY

One or more deficiencies of the prior art are solved by way of embodiments of the wig grip apparatus in accordance with the present disclosure.

BRIEF DESCRIPTION OF THE DRAWINGS

Further advantages of the present invention may become apparent to those skilled in the art with the benefit of the following detailed description of the preferred embodiments and upon reference to the accompanying drawings in which:

FIG. 1 is a diagrammatic bottom plan view of one example wig grip apparatus in accordance with the present disclosure;

FIG. 2 is a diagrammatic top plan view of the example wig grip apparatus shown in FIG. 1;

FIG. 3 is a diagrammatic front view illustrating the example wig grip apparatus of FIG. 1 having been secured to the head of a wearer prior to application of a wig;

FIG. 4 is a diagrammatic rear view illustrating the example wig grip apparatus of FIG. 1 secured to the head of a wearer prior to application of the wig, with the complementary fastener elements being in their releasable gripping engagement with one another;

FIG. 5 diagrammatic right-front perspective view illustrating the example wig grip apparatus of FIG. 1 secured to the head of a wearer prior to application of the wig, with the complementary fastener elements being in their releasable gripping engagement with one another;

FIG. 6 diagrammatic left-front perspective view illustrating the example wig grip apparatus of FIG. 1 secured to the head of a wearer prior to application of the wig;

FIG. 7 is a diagrammatic front view illustrating the example wig grip apparatus of FIG. 1 secured to the head of a wearer, and the wig in the process of being applied over the wig grip apparatus;

FIG. 8 is a diagrammatic front view similar to that of FIG. 7, but wherein the forward section of the wig foundation has been brought into position to at least partially overlap with the frontal segment of the mesh element; and

FIG. 9 is a diagrammatic front view similar to that of FIG. 8, but wherein application of the wig over the wig grip apparatus is complete, and the forward section of the wig foundation at least partially overlaps with the frontal segment of the mesh element.

DETAILED DESCRIPTION OF THE PREFERRED EMBODIMENTS

Referring now to the drawings, like reference numerals designate identical or corresponding features throughout the several views.

With reference to the several drawings, embodiments of a wig grip apparatus are shown generally at **100**, and are configured to facilitate enhanced securement of a wig **102** to the head (scalp) **106** of a wearer. The wig grip apparatus **100** may preferably comprise at least a first securement member **108**, a second securement member **114** and a mesh element **120**.

Referring to FIGS. **1** and **2**, the first securement member **108** may be comprised of a flexible fabric and may have a first outboard portion **110** and a first inboard portion **112** disposed oppositely of one another. Similarly, the second securement member **114** may be comprised of a flexible fabric and may have a second outboard portion **116** and a second inboard portion **118** disposed oppositely of one another. The first securement member **108** may have a first length **146** and the second securement member **114** may have a second length **148**. The first length **146** may be greater than the second length **148**.

The mesh element **120** may be transparent and affixed to the first inboard portion **112** and the second inboard portion **118**. Such affixing may be way of, for example, stitching, adhesive, a combination thereof or the like. The term "transparent" is generally used herein to refer to a material capable of transmitting light therethrough so that bodies and surfaces lying beneath can be clearly seen through the material. Examples of a transparent mesh may include mesh fabrics that are fine or sheer enough to be seen through. More particularly, in certain preferred embodiment of the wig grip apparatus **100**, the mesh element **120** may have a percent visible transmittance of at least 70%. In particular preferred embodiment of a wig grip apparatus **100**, the mesh element **120** may have a percent visible transmittance of at least 85%. In certain preferred embodiment of a wig grip apparatus **100**, the mesh element **120** may be comprised of a nylon mesh fabric, such as a hexagonal nylon mesh fabric. In specific preferred embodiment of a wig grip apparatus **100**, the mesh element **120** is T-shaped (e.g., includes two distinct portions that extend orthogonally to one another).

The first outboard portion **110** and second outboard portion **116** are preferably configured to be placed into releasable gripping engagement with one another. In preferred embodiments of a wig grip apparatus **100**, the first and second outboard portions **110** and **116** may include complementary fastener elements **142** and **144** which are mutually engageable for providing the aforementioned releasable gripping engagement. The complementary fastener elements may be, for example, a first hook-and-loop fastener member and a second hook-and-loop fastener member (i.e., one fastener element having one more hooks and the other fastener element having one or more loops).

Referring to FIGS. **1** and **2**, the securement members **108** and **114** may each include a forward edge **126** and an opposing rearward edge **128**. The mesh element **120** may include a frontal segment **130** having a forward periphery **132**, and the forward periphery **132** may preferably be in

alignment with the forward edges **126**. In certain embodiments, the forward periphery **132** and the forward edges **126** may collectively follow a non-linear forward pathway (See, for example, FIGS. **1** and **2**). The non-linear forward pathway may be arcuate or angled in some fashion.

Referring to FIGS. **1** and **2**, the mesh element **120** may include a parting-line segment **134** extending oppositely of the forward periphery **132**. The frontal segment **130** may have a frontal segment width **136**, and the parting-line segment **134** may have a parting-line segment width **138** defined in parallel with the frontal segment width **136**. In certain preferred embodiments of a wig grip apparatus **100**, the frontal segment width **136** is greater than the parting line segment width **138**.

Referring to FIG. **1**, the parting-line segment **134** may include a rearward periphery **140**. The rearward periphery **140** may be in alignment with the rearward edges **128**. In such embodiments, the rearward periphery **140** and the rearward edges **128** may collectively follow a non-linear rearward pathway (See, for example, FIGS. **1** and **2**). The non-linear rearward pathway may be arcuate or angled in some fashion.

Referring to FIGS. **1** and **2**, the first securement member **108** may have a first inner surface **150** and a first outer surface **152**. Similarly, the second securement member **114** may have a second inner surface **154** and a second outer surface **156**. In particular preferred embodiments of the wig grip apparatus **100**, the first and second securement members **110** and **114** may be generally opaque and may comprise velvet or velour. For example, referring to FIGS. **1** and **6**, the inner surfaces **150** and **154** may comprise a velour with piled fibers oriented unidirectionally so as to cause increased friction between the securement members and the scalp **106** of the wearer when the wig grip apparatus **100** is pulled in a rearward direction **158** across the scalp **106** (i.e., higher friction than friction caused by movement of the wig grip apparatus in the forward direction **160**). Additionally or in the alternative, referring to FIGS. **2** and **6**, the outer surfaces **152** and **156** may comprise a velour with piled fibers oriented unidirectionally so as to cause increased friction between the securement members and the wig foundation **104** when the wig foundation **104** is pulled in a rearward direction **158** across the wig grip apparatus **100** (i.e., higher friction than friction caused by movement of the wig in the forward direction **160**). These frictional adaptations allow the wig grip apparatus **100** to help supportingly affix the wig **102** to the scalp **106** of the wearer, particularly in the case of heavier wigs that tend to pull backwards from the forehead of the wearer.

FIGS. **7-9** illustrate a sequence of applying the wig **102** having a wig foundation **104** to the head **106** of a wearer, with the wig grip apparatus **100** disposed therebetween. Various embodiments of a wig grip apparatus **100** may be adapted for use with lace top wigs and frontals. Lace foundation wigs and frontals generally have a transparent foundation **104** and need to lay very flat to optimally produce a natural appearance. When a conventional gripping object is worn underneath such conventional wigs and frontals, that object is typically visible to the human eye. Advantageously, the transparency of the mesh element **120** and its ability to lay flat against the scalp **106** allows the natural appearance and color of the wearer's scalp **106** to pass through the wig grip apparatus **100** and the wig foundation **104**. The mesh element **120** is generally configured to sit flat on the forehead when the user's front hairline would be and where part of the lace wig or frontal will be positioned. This allows the wearer to secure the wig or

frontal to the head in the flattest, most natural way possible, thereby avoiding creating bulk that may appear unnatural near the front and/or parting line of the hairpiece. Such construction also helps it appear to an outside observer that the hair stands of the wig **102** interface directly with the scalp **106** of the wearer.

While embodiments of the invention have been illustrated and described, it is not intended that these embodiments illustrate and describe all possible forms of the invention. Rather, the words used in the specification are words of description rather than limitation, and it is understood that various changes may be made without departing from the spirit and scope of the invention.

What is claimed is:

1. A wig grip apparatus for facilitating enhanced securement of a wig to the head of a wearer, the wig grip apparatus comprising:

a first securement member comprised of velvet or velour and having a first outboard portion and a first inboard portion disposed oppositely of one another;

a second securement member comprised of velvet or velour and having a second outboard portion and a second inboard portion disposed oppositely of one another; and

a mesh element being transparent and affixed between the first inboard portion and the second inboard portion; wherein the first outboard portion and second outboard portion are configured to be placed into releasable gripping engagement with one another; and wherein

(a) the first securement member, the second securement member and the mesh element collectively form a band configured to encircle a head of a wearer when the first outboard portion and second outboard portion are in said releasable gripping engagement with one another;

(b) the mesh element includes a forward periphery extending from the first inboard portion to the second inboard portion; and

(c) the wig grip apparatus terminates at the forward periphery.

2. A wig grip apparatus as defined in claim 1 wherein the mesh element is affixed to the first and second inboard portions by way of stitching, adhesive or a combination thereof.

3. A wig grip apparatus as defined in claim 1 wherein the mesh element is comprised of a nylon mesh fabric.

4. A wig grip apparatus as defined in claim 3 wherein the nylon mesh fabric is hexagonal.

5. A wig grip apparatus as defined in claim 1 wherein (a) the securement members each include a forward edge and an opposing rearward edge;

(b) the mesh element includes a frontal segment having the forward periphery; and

(c) the forward periphery is in alignment with the forward edges.

6. A wig grip apparatus as defined in claim 5 wherein the forward periphery and the forward edges collectively follow a non-linear forward pathway.

7. A wig grip apparatus as defined in claim 5 wherein (a) the mesh element includes a parting-line segment extending oppositely of the forward periphery;

(b) the frontal segment has a frontal segment width;

(c) the parting-line segment has a parting-line segment width defined in parallel with the frontal segment width; and

5

- (d) the frontal segment width is greater than the parting line segment width.
- 8. A wig grip apparatus as defined in claim 7 wherein
 - (a) the parting-line segment includes a rearward periphery; and
 - (b) the rearward periphery is in alignment with the rearward edges.
- 9. A wig grip apparatus as defined in claim 8 wherein the rearward periphery and the rearward edges collectively follow a non-linear rearward pathway.
- 10. A wig grip apparatus as defined in claim 1 wherein the first and second outboard portions include complementary fastener elements for providing the releasable gripping engagement.
- 11. A wig grip apparatus as defined in claim 10 wherein the complementary fastener elements are a first hook-and-loop fastener member and a second hook-and-loop fastener element.
- 12. A wig grip apparatus as defined in claim 10 wherein the first securement member has a first length and the second securement member has a second length, the first length being greater than the second length.
- 13. A wig grip apparatus as defined in claim 1 wherein the mesh element is T-shaped.
- 14. A wig grip apparatus as defined in claim 1 wherein the first and second securement members are opaque.
- 15. A wig grip apparatus for facilitating enhanced securement of a wig to the head of a wearer, the wig grip apparatus comprising:
 - a first securement member comprised of an opaque flexible fabric and having a first outboard portion and a first inboard portion disposed oppositely of one another;
 - a second securement member comprised of an opaque flexible fabric and having a second outboard portion and a second inboard portion disposed oppositely of one another; and
 - a mesh element being transparent and affixed to the first inboard portion and the second inboard portion; wherein
 - (a) the securement members each include a forward edge and an opposing rearward edge;
 - (b) the mesh element includes a frontal segment having a forward periphery;
 - (c) the forward periphery is in alignment with the forward edges;
 - (d) the first outboard portion and second outboard portion are configured to be placed into releasable gripping engagement with one another;
 - (e) the mesh element includes a parting-line segment extending oppositely of the forward periphery;
 - (f) the frontal segment has a frontal segment width;
 - (g) the parting-line segment has a parting-line segment width defined in parallel with the frontal segment width;
 - (h) the frontal segment width is greater than the parting line segment width;
 - (i) the first and second outboard portions include mutually-engageable complementary fastener elements for providing the releasable gripping engagement;
 - (j) the first securement member, the second securement member and the mesh element collectively form a band configured to encircle a head of a wearer when

6

- the first outboard portion and second outboard portion are in said releasable gripping engagement with one another; and
- (k) the wig grip apparatus terminates at the forward periphery.
- 16. A wig grip apparatus as defined in claim 15 wherein
 - (a) the parting-line segment includes a rearward periphery; and
 - (b) the rearward periphery is in alignment with the rearward edges.
- 17. A wig grip apparatus as defined in claim 15 wherein the mesh element is comprised of a nylon mesh fabric.
- 18. A wig grip apparatus as defined in claim 15 wherein the first securement member has a first length and the second securement member has a second length, the first length being greater than the second length.
- 19. A wig grip apparatus as defined in claim 15 wherein the first and second securement members comprise a velour fabric.
- 20. A wig grip apparatus for facilitating enhanced securement of a wig to the head of a wearer, the wig grip apparatus comprising:
 - a first securement member comprised of a velvet or velour and having a first outboard portion and a first inboard portion disposed oppositely of one another;
 - a second securement member comprised of a velvet or velour and having a second outboard portion and a second inboard portion disposed oppositely of one another; and
 - a mesh element being transparent and affixed to the first inboard portion and the second inboard portion; wherein the first outboard portion and second outboard portion are in mutual engagement for securing the wig grip apparatus around the head of the wearer; and wherein
 - (a) the first securement member, the second securement member and the mesh element collectively form a band configured to encircle a head of a wearer;
 - (b) the mesh element includes a forward periphery extending from the first inboard portion to the second inboard portion; and
 - (c) the wig grip apparatus terminates at the forward periphery.
- 21. A wig grip apparatus as defined in claim 20 wherein the inboard portions are separated from one another by way of the mesh element.
- 22. A wig grip apparatus as defined in claim 20 wherein
 - (a) the mesh element is affixed to the first and second inboard portions by way of stitching, adhesive or a combination thereof;
 - (b) the securement members include a forward edge and an opposing rearward edge; and
 - (c) the mesh element extends from the forward edge to the rearward edge.
- 23. A wig grip apparatus as defined in claim 22 wherein
 - (a) the securement members are opaque; and
 - (b) the mesh element is comprised of a hexagonal nylon mesh fabric.

* * * * *