

Model MP-4R and MP-4RSS
MULTI-PAK™ RESCUE AIR CARTS
Manual No. PAK013
(Rev 1 January 2001)

Operating Manual

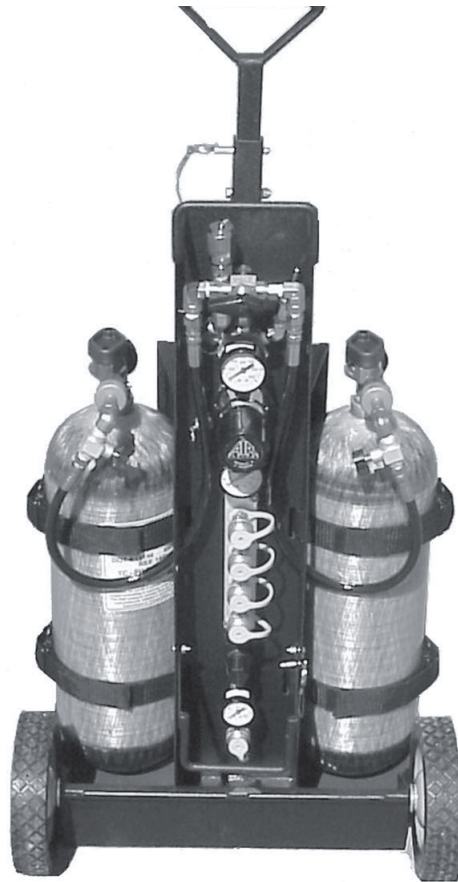

[Air Systems MP-2H MULTI PAK SCBA Confined Space Air Cart](#)
[Air Systems MP-2L MULTI PAK SCBA Confined Space Air Cart](#)
[Air Systems MP-4H MULTI PAK SCBA Confined Space Air Cart](#)
[Air Systems MP-4R MULTI PAK SCBA Confined Space Rescue Air Cart](#)
[Air Systems MP-4RSS MULTI PAK SCBA Confined Space Rescue Cart](#)

Table of Contents

Specifications.....	3
Setup/Operation.....	4-5
Cylinder Change.....	6
Shutdown.....	6
High Pressure Airline General Maintenance & Inspection.....	6
Parts Identification.....	7
Warranty Disclaimer.....	8

Specifications

Size:	35" H x 20.5" W x 15" D (Handle collapsed)
Weight:	41 lbs.
Frame:	Steel (powder coat)
Cylinder Straps:	Four (4) adjustable
Whip Assemblies:	5000psi (345 bar) rated 4:1 safety factor
Bleeder Valves:	Allows depressurization of hand tight nut
Check Valves:	Allows independent cylinder operation
Low Pressure Whistle:	Pneumatic - set at approximately 500psi (34.5 bar) descending pressure
Primary Regulator:	0 - 5500psi (379 bar) inlet 0 - 125psi (8.6 bar) discharge
Primary Regulator Flow Rate:	80cfm (2260 LPM) @ 125psi (8.6 bar) discharge pressure
Secondary Regulator Pressure:	0 - 300psi (20.6 bar) inlet 0 - 125 psi (8.6 bar) discharge
Secondary Regulator Flow Rate:	0-125psi inlet; 0-125psi outlet Minimum flow rate: 5cfm @ 100psi inlet pressure and 80 psi outlet Maximum flow rate: 18cfm @ 100psi inlet pressure and 70 outlet
Relief Valve:	125psi (8.6 bar) ASME preset
Air Distribution:	Four (4) quick connect fittings
Intrinsically Safe:	No electronic devices

Setup/Operation

STEP 1)

Install cylinders on cart. Secure cylinders by tightening the straps at the buckle and mate the velcro sections to prevent slipping. 2216psi (153 bar) or 4500psi (310 bar) cylinders can be used.

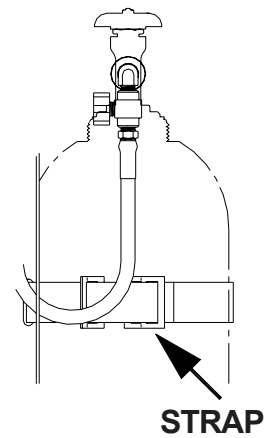

STEP 2)

Install universal CGA-347 hand tight nuts to the cylinder valves and tighten. Insure both bleeder valves are closed by turning fully clockwise.

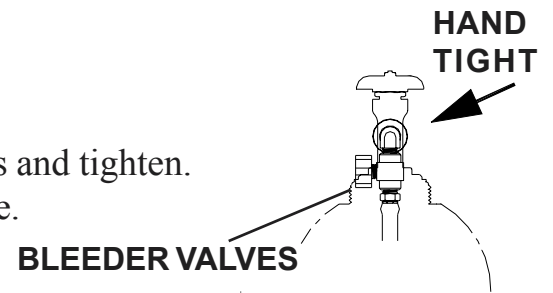

STEP 3)

Open one cylinder.

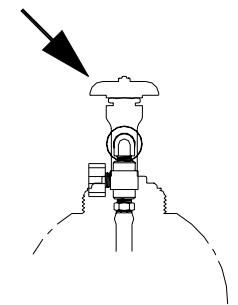

STEP 4)

Index the selector valve so that it points to the open cylinder. At this time, the low pressure warning alarm will sound until it sets itself at approximately 1000psi (69 bar). Check reading on gauge to verify that it is full. Close the cylinder

SELECTOR VALVE

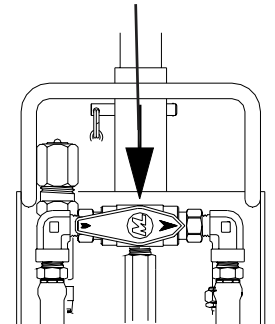

STEP 5) LOW PRESSURE ALARM TEST

Set the required respirator pressure with the regulator control knob and bleed the pressure at either the relief valve or by partially engaging a male plug into one of the respirator couplings. This depressurizes the manifold and simulates low cylinder pressure. The low pressure warning alarm will sound at approximately 500psi (35bar).

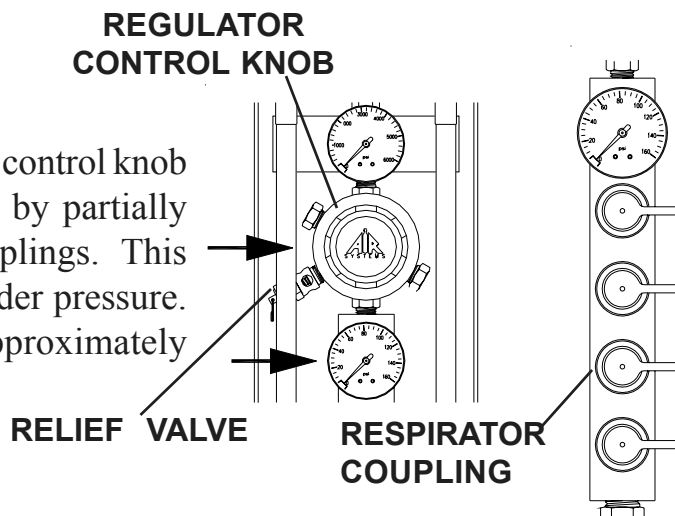

STEP 6)

Index the selector valve toward the other cylinder and open the cylinder valve. At this time the low pressure warning alarm will resound until it sets itself at approximately 1000psi (69 bar). Check reading on gauge to verify cylinder is full. Either cylinder can now be selected for operation.

AUXILIARY INLET PORT

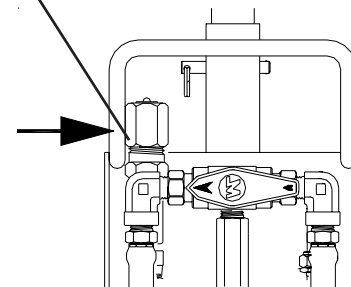

Optional

Install high pressure connect whip to auxiliary inlet port (CGA-347). This step can be done after Step 6 or anytime during the operation of the system. This auxiliary inlet port is not controlled by the selector valve. Auxiliary inlet air directly feeds the regulator system.

STEP 7)

Couple respirators and lengths of hoses to the manifold and readjust pressure regulator if necessary. The system is now operational.

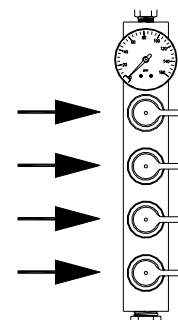

Optional

If pneumatic equipment is to be used which requires a different pressure than the respirators, set the secondary low pressure regulator accordingly. This is a locking regulator; push to lock, pull to unlock.

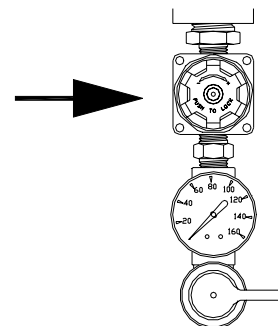

Cylinder Change

When the cylinder in use has been depleted to approximately 500psi (35bar), the low pressure warning alarm will sound indicating that the cylinder needs to be replaced.

To change a cylinder while the cart is still in use:

- 1) Open the second cylinder and note the gauge pressure to assure that it is full.
- 2) Index the selector valve towards the full cylinder.
- 3) Close the drained cylinder valve and open the corresponding bleeder valve to relieve pressure on the hand tight nut.
- 4) Remove the drained cylinder and install a full cylinder in its place. Connect the CGA-347 hand tight nut to the cylinder valve, close the bleeder valve on the connect whip. It is now ready for use when the other cylinder pressure descends to 500psi or lower.

Note: The system is equipped with check valves that will prevent back flow from the other cylinder in use.

Shutdown

Make sure all personnel have egressed the hazardous area and have disconnected from the breathing air system.

- 1) Close cylinder valves.
- 2) Depressurize manifold by pulling the relief valve ring.
- 3) Close the regulator by turning the control knob counterclockwise.
- 4) Disconnect airline hoses and reinstall dust caps.
- 5) Remove connections from cylinders and reinstall cylinder valve covers (if applicable).

High Pressure Airline General Maintenance & Inspection

Monthly

1. Check regulators, gauges, and valves for external leakage.
2. Inspect cylinder valves for proper closure.
3. Check cylinder pigtailed for cleanliness, flexibility, wear, leakage, blisters on hose, thread damage, and O-rings on CGA fittings. Replace damaged items immediately.

Annually

1. Check relief valve's pressure setting.
2. Check regulator function by opening and closing regulator valve knob fully.

Every 4 years

1. Replace all flexible pigtailed - consult factory.

Parts Identification

ITEM #	DESCRIPTION	PART #
1	LOW PRESSURE WHISTLE	AC-PA25
2	CGA-347 HAND-TIGHT NUT/NIPPLE	SS347HT
3	BLEED VALVE	VAL030
4	CYLINDER STRAP	HDWR113A
5	QUICK DISCONNECT, HANSEN SERIES	QDH3SL4M
5A	QUICK DISCONNECT, SCHRADER SERIES	QDSSL4M
6	DUST CAP, HANSEN SERIES	QDH3DCAP
6A	DUST CAP, SCHRADER SERIES	QDSDCAP
7	SECONDARY OUTLET PRESSURE GAUGE	GA15160B
8	SECONDARY PRESSURE REGULATOR	WL013
9	OUTLET PRESSURE GAUGE	GA20160B
10	PRESSURE REGULATOR	REG-5000NG
11	INLET PRESSURE GAUGE	GA206KB
12	3-WAY BALL VALVE	VAL153
13	CGA-347 PRESSURE CAP	SS347CAP
14	CGA-347 MALE ADAPTER	SS4F347AM

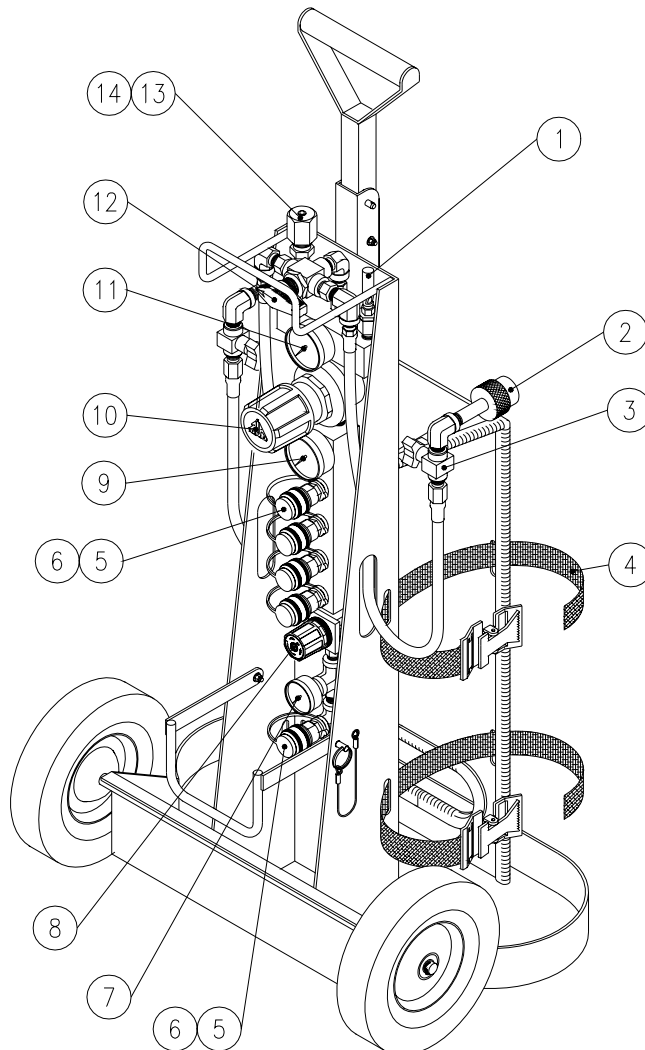

Warranty Disclaimer

Air Systems' manufactured equipment is warranted to the original user against defects in workmanship or materials under normal use for one year after date of purchase. Any part which is determined by Air Systems to be defective in material or workmanship will be, as the exclusive remedy, repaired or replaced at Air Systems' option. This warranty does not apply to electrical systems or electronic components. Electrical parts are warranted, to the original user, for 90 days from the date of sale. During the warranty period, electrical components will be repaired or replaced at Air Systems' option.

NO OTHER WARRANTY, EXPRESSED OR IMPLIED, AS TO DESCRIPTION, QUALITY, MERCHANTABILITY, FITNESS FOR A PARTICULAR PURPOSE, OR ANY OTHER MATTER IS GIVEN BY AIR SYSTEMS IN CONNECTION HEREWITH. UNDER NO CIRCUMSTANCES SHALL THE SELLER BE LIABLE FOR LOSS OF PROFITS, ANY OTHER DIRECT OR INDIRECT COSTS, EXPENSES, LOSSES OR DAMAGES ARISING OUT OF DEFECTS IN, OR FAILURE OF THE PRODUCT OR ANY PART THEREOF.

The purchaser shall be solely responsible for compliance with all applicable Federal, State and Local OSHA and/or MSHA requirements. Although Air Systems International believes that its products, if operated and maintained as shipped from the factory and in accordance with our "operations manual", conform to OSHA and/or MSHA requirements, there are no implied or expressed warranties of such compliance extending beyond the limited warranty described herein. Product designs and specifications are subject to change without notice. **Rev 2 12/98**

Air leaks are not covered under warranty except when they result from a defective system component, i.e. an on/off valve or regulator or upon initial delivery due to poor workmanship. Air leaks due to poor delivery or damage will be covered under delivery claims. Minor air leaks are part of routine service and maintenance and are the responsibility of the customer just as are filters and oil changes.