

EAC-97 SERIES

Covers Models EAC-97ENB, EAC-97HENB,
EAC-97NB, EAC-97PENB, EAC-97PHNB,
EAC97PHENB, EAC-97PTNB & EAC-97HNB

Manual No. ERGO009
(Rev 0 September 2006)

Operating Manual

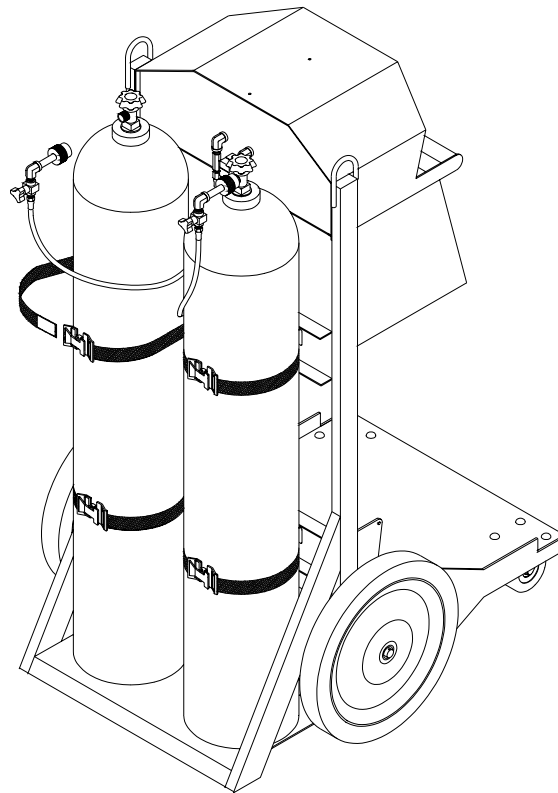

[Air Systems EAC-97ENB ERGO AIR SCBA Breathing Air Cart](#)
[Air Systems EAC-97HENB ERGO AIR SCBA Breathing Air Cart](#)
[Air Systems EAC-97HNB ERGO AIR SCBA Breathing Air Cart](#)
[Air Systems EAC-97NB ERGO AIR SCBA Breathing Air Cart System](#)
[Air Systems EAC-97PENB ERGO AIR SCBA Breathing Air Cart](#)
[Air Systems EAC-97PHENB ERGO AIR SCBA Breathing Air Cart](#)
[Air Systems EAC-97PHNB ERGO AIR SCBA Breathing Air Cart](#)
[Air Systems EAC-97PTNB ERGO AIR SCBA Breathing Air Cart](#)

OVERVIEW

The Ergo-Air® Cart is an ergonomically designed mobile cylinder cart for long duration breathing air applications. The unique design helps reduce back/shoulder injuries and allows movement by people of small stature. Low pressure warning alarm is standard. Deck mounted hose reels and storage cabinets are just a few of the options available.

SPECIFICATIONS FOR MODELS EAC-97ENB, EAC-97HENB, EAC-97PENB & EAC97PHENB

Cart Dimensions	32"W x 55"H x 38¼" D (81cm W x 140cm H x 97cm D)
Weight without Cylinders	250 lbs (114 kg)
Frame	Steel Powder Coated
Cylinder Straps	Four (4) adjustable straps to accommodate different size cylinders
Wheels/Casters	Standard: 16" semi-pneumatic (front) 6" soft tread swivel casters with brake (rear) Optional: 16" pneumatic (front) 10" pneumatic casters with brake (rear)
Whip Assemblies	Thermo plastic 5000psi (345 bar) rated 4:1 safety factor
Bleeder Valves	Allows depressurization of hand tight nut before cylinder removal. Model EAC-97HENB only
Check Valves	Allows independent cylinder operation and removal without complete system shutdown.
Warning Alarm	9 VDC audible and visual alarms for low pressure warning Set at approximately 500psi (34.5 bar)
Primary Regulator Pressure (Model EAC-97ENB & EAC-97PENB)	0-3000 psi (205 bar) inlet 0-125psi (8.6 bar) discharge
Primary Regulator Pressure (Model EAC-97HENB & EAC97PHENB)	0-5500psi (379 bar) inlet 0-125psi (8.6 bar) discharge
Primary Regulator Flow Rate	80cfm (2260 LPM) @ 125psi (8.6 bar) discharge pressure
Relief Valve	125psi (8.6 bar) ASME preset
Air Distribution	Four (4) regulated quick connect fittings
Transportation	2 eyelets for sling attachment--vertical lifting
Ergo Design	Raising Cart: 15lbs. of force Lowering Cart: 35lbs. of force

PARTS IDENTIFICATION

MODELS EAC-97ENB, EAC-97HENB, EAC-97PENB & EAC97PHENB

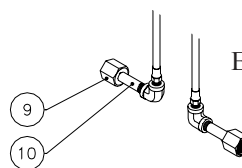
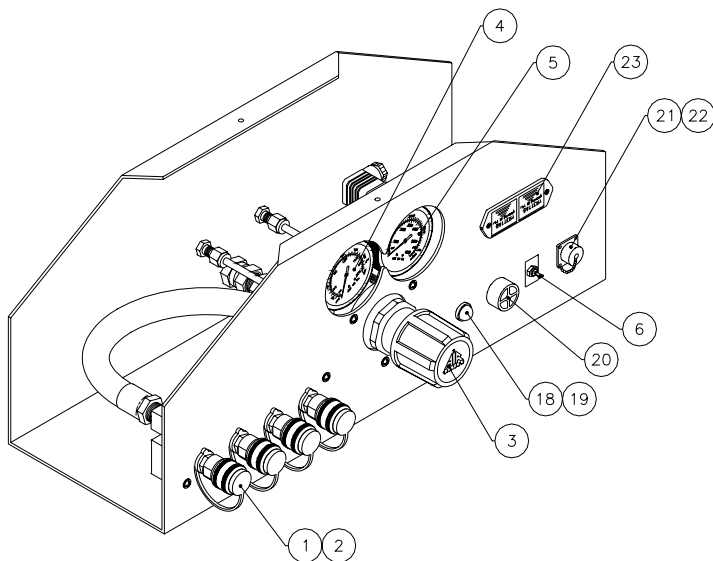
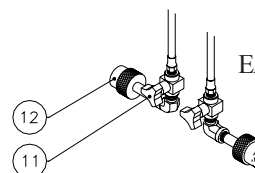
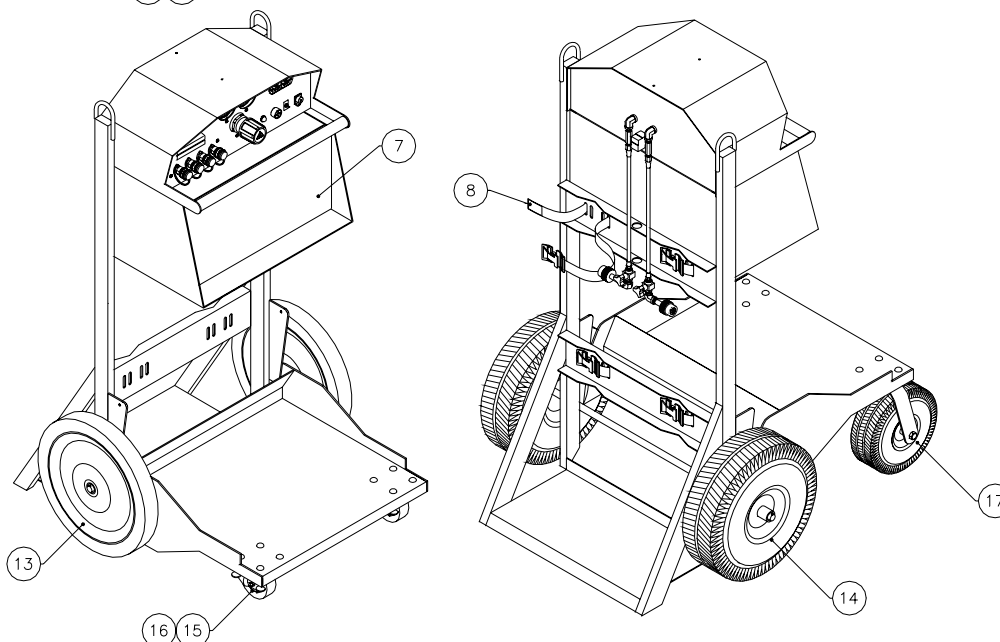
 Models
 EAC-97ENB & EAC-97PENB

 Models
 EAC-97HENB & EAC-97PHENB

ITEM #	DESCRIPTION	PART #
1	RESPIRATOR COUPLING, HANSEN	QDH3SL6M
1A	RESPIRATOR COUPLING, SCHRADER	QDSSL6M
2	DUST CAP, HANSEN	QDH3DCAP
2A	DUST CAP, SCHRADER	QDSDCAP
3	PRESSURE REGULATOR, 3000 PSI (EAC-97ENB, EAC-97PENB)	REG-3000
3A	PRESSURE REGULATOR, 5000 PSI (EAC-97HENB, EAC-97PHENB)	REG-5000
4	PRESSURE GAUGE, 0-200 PSI	GA25200SRG
5	PRESSURE GAUGE, 0-4000 PSI	GA254KSREG
5A	PRESSURE GAUGE, 0-6000 PSI	GA256KSREG
6	LOW PRESSURE ALARM ON/OFF SWITCH	ELSW005
7	STORAGE BOX	EAC-97SBU
8	CYLINDER STRAP	HDWR113B
9	CGA-346 NUT (EAC-97ENB, EAC-97PENB)	HPBR025
10	CGA-346 STEM WITH CHECK VALVE (EAC-97ENB, EAC-97PENB)	HPBR027
11	BLEEDER VALVE (EAC-97HENB, EAC-97PHENB)	VAL030
12	CGA-347 HAND-TIGHT (EAC-97HENB, EAC-97PHENB)	SS347HT
13	16" WHEEL, SEMI-PNEUMATIC	HDWR145
14	16" WHEEL, PNEUMATIC (EAC-97PENB & EAC-97PHENB)	HDWR120
15	5" CASTER	HDWR122
16	BRAKE KIT FOR 5" CASTER	HDWR122A
17	10" PNEUMATIC CASTER (EAC-97PENB & EAC-97PHENB)	HDWR101
18	12 VDC BULB	ELDS001
19	RED LENS	ELDS005
20	AUDIBLE ALARM	ELLS004
21	REMOTE ALARM JACK	ELJP004
22	REMOTE ALARM JACK COVER	ELJP005
23	BATTERY HOLDER	MONC006

SETUP FOR MODELS MODELS EAC-97ENB, EAC-97HENB, EAC-97PENB & EAC97PHENB

Step 1)

Remove clevis pin. Push the handle up and forward to situate the cart in an upright position. Reinstall the clevis pin.

Step 2)

Install, arrange and index the air cylinders so that the valve outlets are facing away from the control panel. Secure cylinders by tightening the straps at the buckle and mating the velcro sections.

Step 3)

Model EAC-97HENB & EAC-97PHENB: Install CGA-347 hand tight nuts on the cylinder valves, and tighten. Insure both bleeder valves are closed by turning fully clockwise.

Model EAC-97ENB & EAC97PENB: Install CGA-346 wrench tight nuts on the cylinder valves, and tighten.

Step 4)

Place the “on/off” toggle switch to the “on” position. The lights and alarms should should. Note: The alarm preset to sound at approximately 500psi (35 bar) descending pressure. If alarms do not activate, replace the 9-volt batteries.

Step 5)

LOW PRESSURE ALARM TEST

Make sure the bleeder valves are closed; open one cylinder:

- a. At this time the alarm should shut off when system pressure reaches 500psi (35bar) or greater.
- b. Check the cylinder pressure on the high pressure gauge.
- c. Set required respirator pressure with the regulator control knob
- d. Close the cylinder valve and slowly bleed off pressure through one of the respirator outlets.
- e. The low pressure alarm should sound and the light should come on at approximatly 500psi (35 bar).
- f. Open the other cylinder and check its pressure on the high pressure gauge.

Step 6)

Couple respirators and lengths of hoses to the manifold, and readjust regulator control knob if necessary. The system is now operational. When a cylinder in use has been depleted to approximately 500psi (35 bar), the low pressure warning alarm will sound, indicating that the cylinder needs to be replaced.

Optional)

A variety of hose reel options are available. If the lower reel is to be used, open the valve located near the inlet. This will pressurize the hose reel.

To change a cylinder while the cart is still in use:

- a. Open the second cylinder and note the gauge pressure to assure that the cylinder is full.
- b. Close the drained cylinder and open the bleeder valve (high pressure version) on the whip to relieve the remaining pressure on the hand tight nut.
- c. The system's check valves will prevent back flow from the other cylinder in use
- d. Replace or fill the drained cylinder and reinstall connecting whip.

**SETUP FOR MODELS EAC-97ENB,
EAC-97HENB, EAC-97PENB & EAC97PHENB**

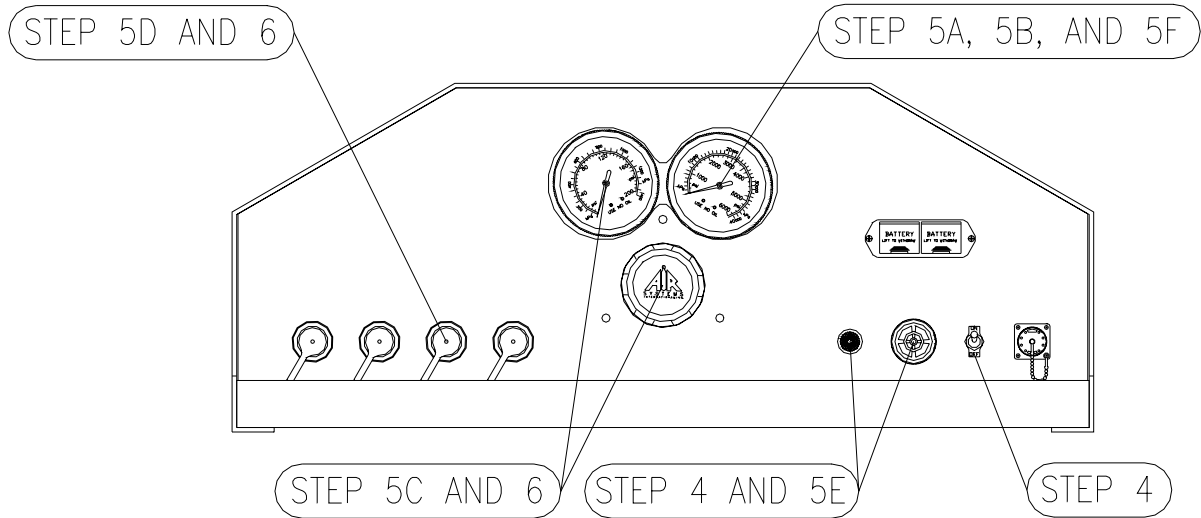
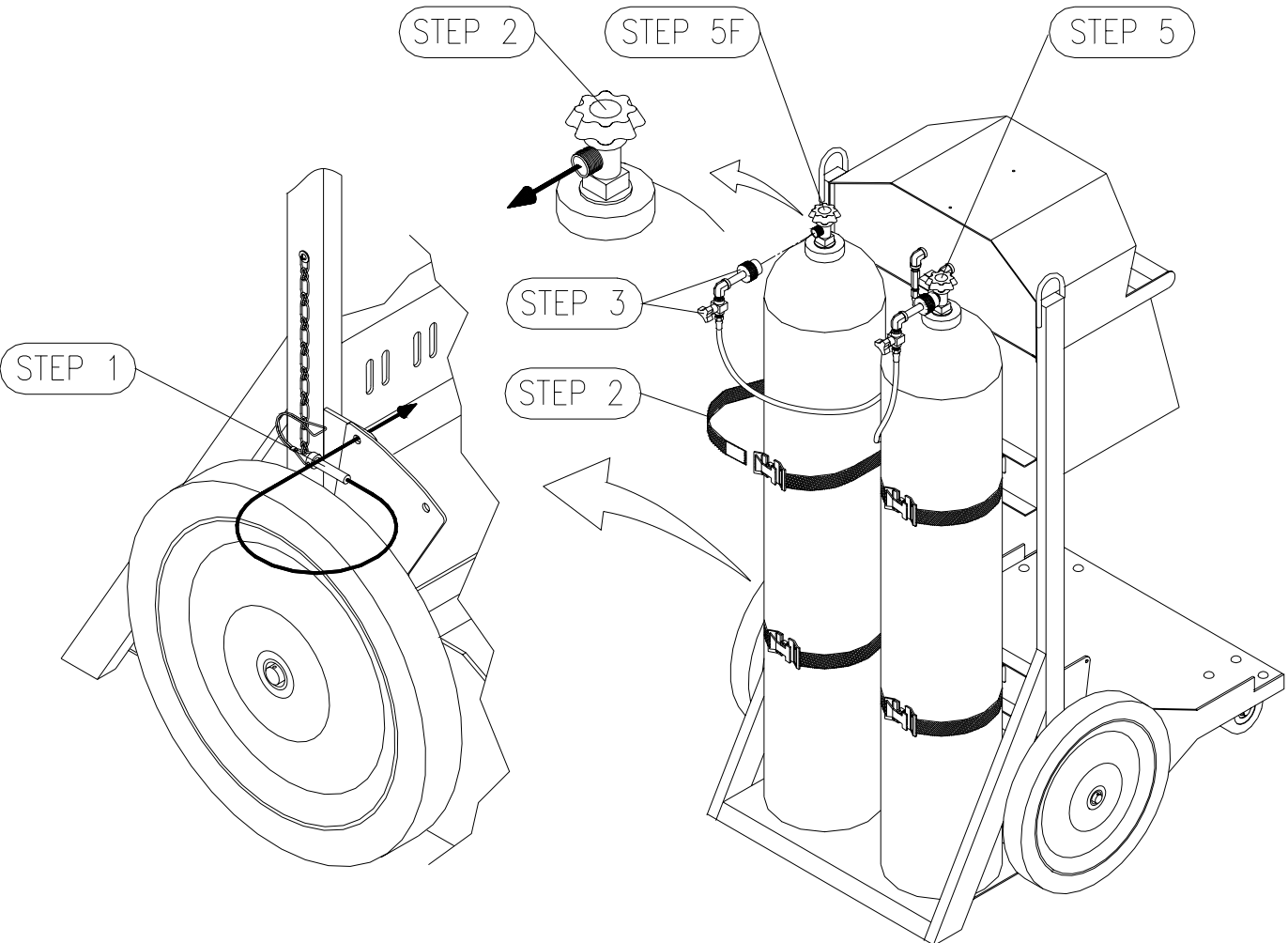

SPECIFICATIONS FOR MODELS EAC-97NB, EAC-97HNB, EAC-97PTNB, & EAC-97PHNB

Cart Dimensions	32"W x 55"H x 38¼" D (81cm W x 140cm H x 97cm D)
Weight without Cylinders	250 lbs (114 kg)
Frame	Steel Powder Coated
Cylinder Straps	Four (4) adjustable straps to accommodate different size cylinders
Wheels/Casters	Standard: 16" semi-pneumatic (front) 6" soft tread swivel casters with brake (rear) Optional: 16" pneumatic (front) 10" pneumatic casters with brake (rear)
Whip Assemblies	Thermo plastic 5000psi (345 bar) rated 4:1 safety factor
Bleeder Valves	Allows depressurization of hand tight nut before cylinder removal. Model EAC-97HENB only
Check Valves	Allows independent cylinder operation and removal without complete system shutdown.
Warning Alarm	Pneumatic whistle alarms for low pressure warning Set at approximately 500psi (34.5 bar)
Primary Regulator Pressure (Model EAC-97NB & EAC- 97PTNB)	0-3000 psi (205 bar) inlet 0-125psi (8.6 bar) discharge
Primary Regulator Pressure (Model EAC-97HNB & EAC-97PHNB)	0-5500psi (379 bar) inlet 0-125psi (8.6 bar) discharge
Primary Regulator Flow Rate	80cfm (2260 LPM) @ 125psi (8.6 bar) discharge pressure
Relief Valve	125psi (8.6 bar) ASME preset
Air Distribution	Four (4) regulated quick connect fittings
Transportation	2 eyelets for sling attachment--vertical lifting
Ergo Design	Raising Cart: 15lbs. of force Lowering Cart: 35lbs. of force

PARTS IDENTIFICATION

MODELS EAC-97NB, EAC-97HNB, EAC-97PTNB, & EAC-97PHNB

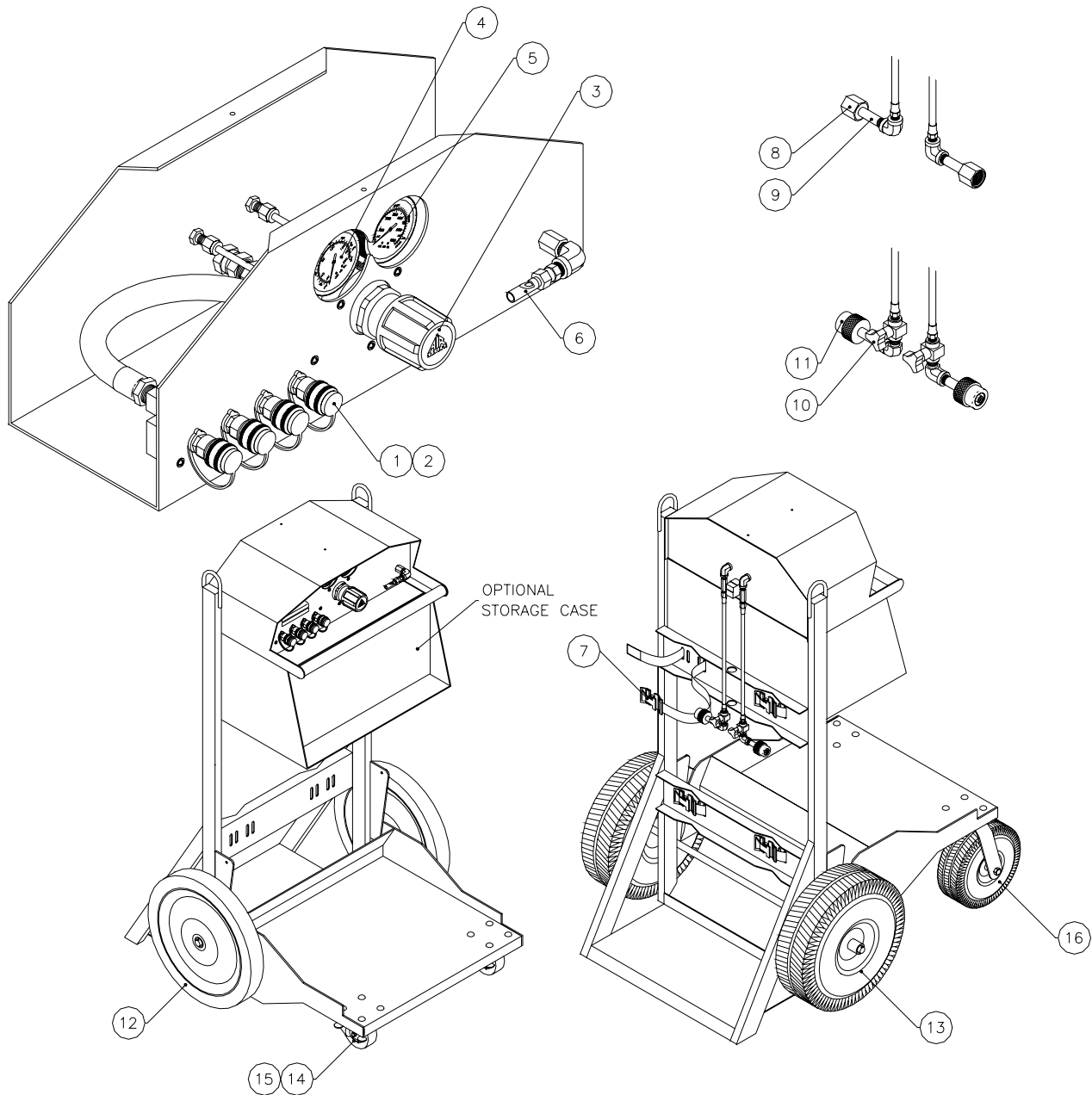

ITEM #	DESCRIPTION	PART #
1	RESPIRATOR COUPLING, HANSEN	QDH3SL6M
1A	RESPIRATOR COUPLING, SCHRADER	QDSSL6M
2	DUST CAP, HANSEN	QDH3DCAP
2A	DUST CAP, SCHRADER	QDSDCAP
3	PRESSURE REGULATOR, 3000 PSI (EAC-97NB)	REG-3000
3A	PRESSURE REGULATOR, 5000 PSI (EAC-97HNB)	REG-5000
4	PRESSURE GAUGE, 0-200 PSI	GA25200SRG
5	PRESSURE GAUGE, 0-4000 PSI	GA254KSREG
5A	PRESSURE GAUGE, 0-6000 PSI	GA256KSREG
6	LOW PRESSURE WHISTLE	AC-PA25
7	CYLINDER STRAP	HDWR113B
8	CGA-346 STEM WITH CHECK VALVE	HPBR027
9	CGA-346 NUT	HPBR025
10	BLEEDER VALVE	VAL030
11	CGA-347 HAND-TIGHT	SS347HT
12	16" WHEEL, SEMI-PNEUMATIC	HDWR145
13	16" WHEEL, PNEUMATIC	HDWR120
14	5" CASTER	HDWR122
15	BRAKE KIT FOR 5" CASTER	HDWR122A
16	10" PNEUMATIC CASTER	HDWR101

SETUP FOR MODELS EAC-97NB, EAC-97HNB, EAC-97PTNB, & EAC-97PHNB

- Step 1)**
Remove clevis pin. Push the handle up and forward to situate the cart in an upright position. Reinstall the clevis pin.
- Step 2)**
Install, arrange and index the air cylinders so that the valve outlets are facing away from the control panel. Secure cylinders by tightening the straps at the buckle and mating the velcro sections.
- Step 3)**
Model EAC-97HNB: Install CGA-347 hand tight nuts on the cylinder valves, and tighten. Insure both bleeder valves are closed by turning fully clockwise.
- Model EAC-97NB:** Install CGA-346 wrench tight nuts on the cylinder valves, and tighten.
- Step 4)**
Open one cylinder. At this time the low pressure warning alarm will sound, until it sets itself at approximately 1000psi (69 bar). Check reading on gauge to verify that it is full. Close the cylinder.
- Step 5)**
Set required respirator pressure with the regulator control knob, and bleed pressure by partially engaging a male plug into one of the respirator fittings. This depressurizes the manifold, and simulates low cylinder pressure. The low pressure warning alarm should sound at approximately 500psi (35 bar).
- Step 6)**
Open the second cylinder. At this time the low pressure warning alarm will resound until it sets itself at approximately 1000psi (69bar). Check reading on gauge to verify that it is full.
- Step 7)**
Couple respirators and lengths of hoses to the manifold, and readjust regulator control knob if necessary. The system is now operational. When a cylinder in use has been depleted to approximately 500psi (35 bar), the low pressure warning alarm will sound, indicating that the cylinder needs to be replaced.
- Optional)**
A variety of hose reel options are available. If the lower reel is to be used, open the valve located near the inlet. This will pressurize the hose reel.

To change a cylinder while the ERGO-AIR® CART is still in use:

1. Open second cylinder and note the gauge pressure to assure that it is full.
2. Close the drained cylinder.
3. **Model EAC-97HNB & EAC-97PHNB:** Open the bleeder valve of the drained cylinder. Remove CGA-347 hand tight nut. Replace with full cylinder. Reinstall connect whip. Close bleeder valve.

Model EAC-97NB & EAC-97PTNB: Loosen CGA-346 wrench tight nut to relieve pressure. Replace with a full cylinder. Reinstall connect whip.

Note: *The system is equipped with check valves that will prevent back flow from the other cylinder in use.*

SETUP FOR MODELS EAC-97NB, EAC-97HNB, EAC-97PTNB, & EAC-97PHNB

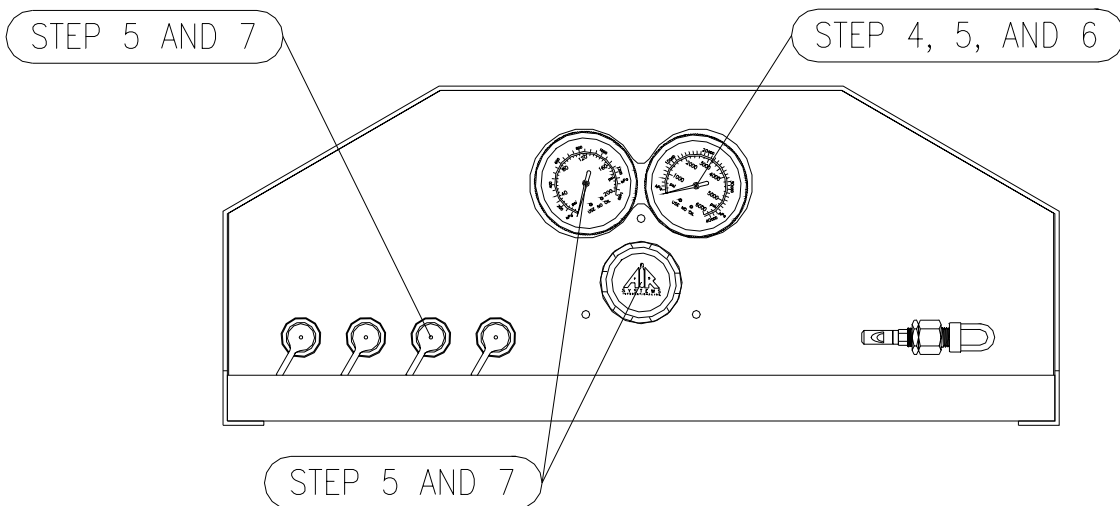
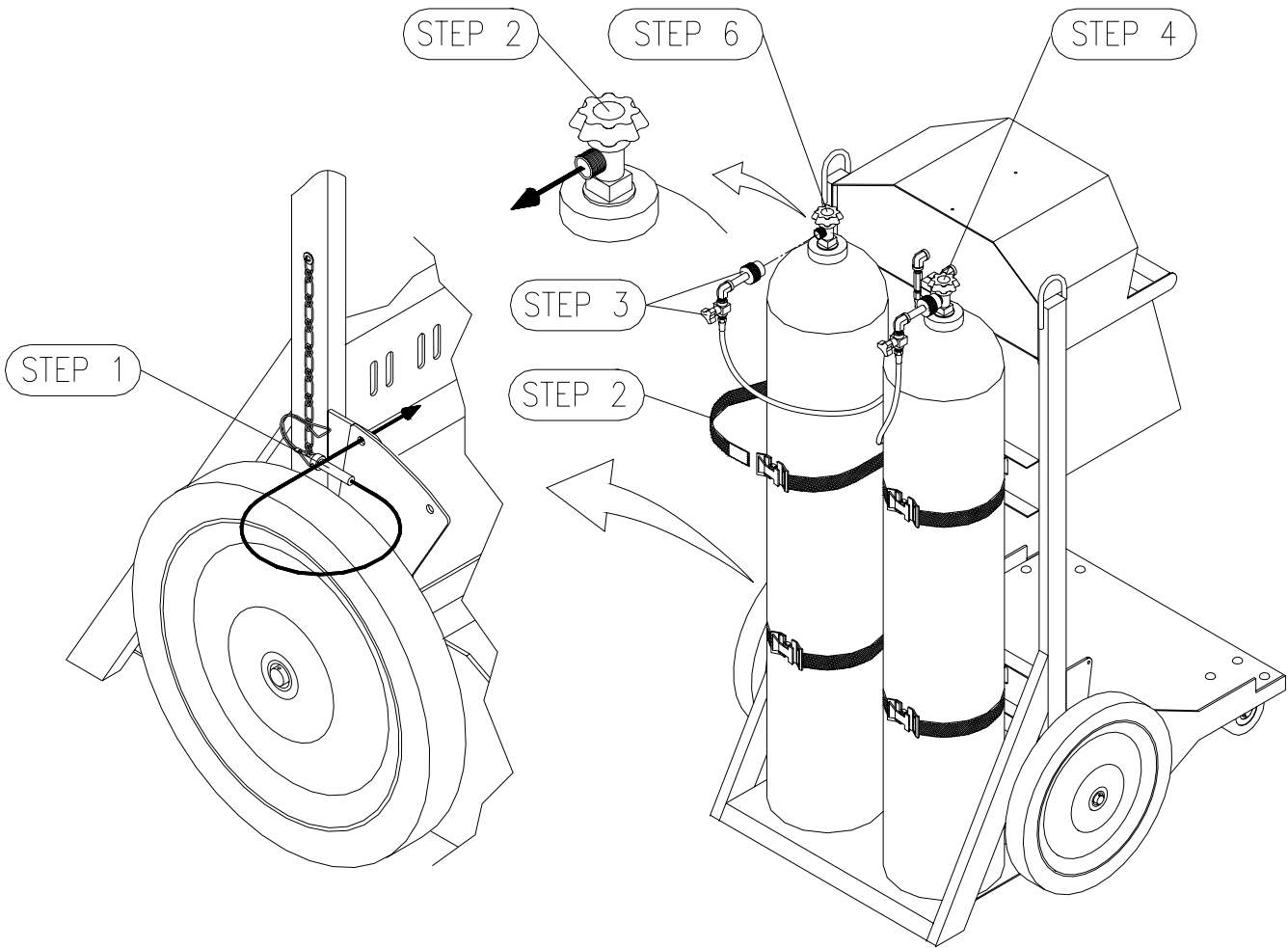

HIGH PRESSURE AIRLINE GENERAL MAINTENANCE & INSPECTION FOR ALL MODELS

Monthly

1. Check regulators, gauges, and valves for external leakage.
2. Inspect cylinder valves for proper closure.
3. Check cylinder pigtails for cleanliness, flexibility, wear, leakage, blisters on hose, thread damage, and O-rings on CGA fittings. Replace damaged items immediately.

Annually

1. Check relief valve's pressure setting.
2. Check regulator function by opening and closing regulator valve knob fully.

Every 4 years

1. Replace all flexible pigtails.

SHUTDOWN FOR ALL MODELS

Make sure all personnel have egressed the hazardous area and have disconnected from the breathing air system.

1. Close cylinder valves.
2. Depressurize manifold pressure by partially engaging male plug into one of the respirator fittings.
3. Close the regulator by turning the control knob counterclockwise.
4. Reinstall dust caps.
5. Remove connections from cylinders. Reinstall cylinder valve covers (if applicable).
6. If transportation of cart is required, remove clevis pin, place foot on base and pull handle until movement stops. Replace clevis pin.

Warranty Disclaimer

Air Systems' manufactured equipment is warranted to the original user against defects in workmanship or materials under normal use for one year after date of purchase. Any part which is determined by Air Systems to be defective in material or workmanship will be, as the exclusive remedy, repaired or replaced at Air Systems' option. This warranty does not apply to electrical systems or electronic components. Electrical parts are warranted, to the original user, for 90 days from the date of sale. During the warranty period, electrical components will be repaired or replaced at Air Systems' option.

NO OTHER WARRANTY, EXPRESSED OR IMPLIED, AS TO DESCRIPTION, QUALITY, MERCHANTABILITY, FITNESS FOR A PARTICULAR PURPOSE, OR ANY OTHER MATTER IS GIVEN BY AIR SYSTEMS IN CONNECTION HEREWITH. UNDER NO CIRCUMSTANCES SHALL THE SELLER BE LIABLE FOR LOSS OF PROFITS, ANY OTHER DIRECT OR INDIRECT COSTS, EXPENSES, LOSSES OR DAMAGES ARISING OUT OF DEFECTS IN, OR FAILURE OF THE PRODUCT OR ANY PART THEREOF.

The purchaser shall be solely responsible for compliance with all applicable Federal, State and Local OSHA and/or MSHA requirements. Although Air Systems International believes that its products, if operated and maintained as shipped from the factory and in accordance with our "operations manual", conform to OSHA and/or MSHA requirements, there are no implied or expressed warranties of such compliance extending beyond the limited warranty described herein. Product designs and specifications are subject to change without notice. **Rev 2 12/98**

Air leaks are not covered under warranty except when they result from a defective system component, i.e. an on/off valve or regulator or upon initial delivery due to poor workmanship. Air leaks due to poor delivery or damage will be covered under delivery claims. Minor air leaks are part of routine service and maintenance and are the responsibility of the customer just as are filters and oil changes.