



<https://engwe-bikes-eu.com>

<https://engwe-bikes.com>

X20

PLEASE READ THIS MANUAL CAREFULLY BEFORE USING YOUR E-BIKE

THANK YOU FOR CHOOSING TO BE PART OF THE ENGWE E-BIKES FAMILY.

We invite you to read through this owner's manual to learn about your e-bike and what it's like to own one.

First of all, remember to be safe outside. Your bike is an accessory to your lifestyle and activities. Always follow best practices and traffic rules.

Even in this ever-evolving technology, your e-bike is essentially a bicycle, and as such requires basic maintenance and care to always function properly.

Preventative maintenance is the name of the game. We invite you to grow with us, taking advantage of our modular design for technology.

Instructions, videos, and live support are being created to provide all the knowledge you need to get the most out of your Engwe E-bike.

CONTACT INFORMATION

Engwe E-Bikes

service@engwe-bikes.com

www.engwe-bikes.com

TABLE OF CONTENTS

PRODUCTS INTRODUCTION AND ASSEMBLY

INSTRUCTION.....	1
DISPLAY GUIDE.....	12
YOUR FIRST RIDE.....	19
SECURITY AND WARNINGS.....	21
BATTERY AND MAINTENANCE.....	24
TROUBLE SHOOTING.....	27
LIMITED WARRANTY.....	28

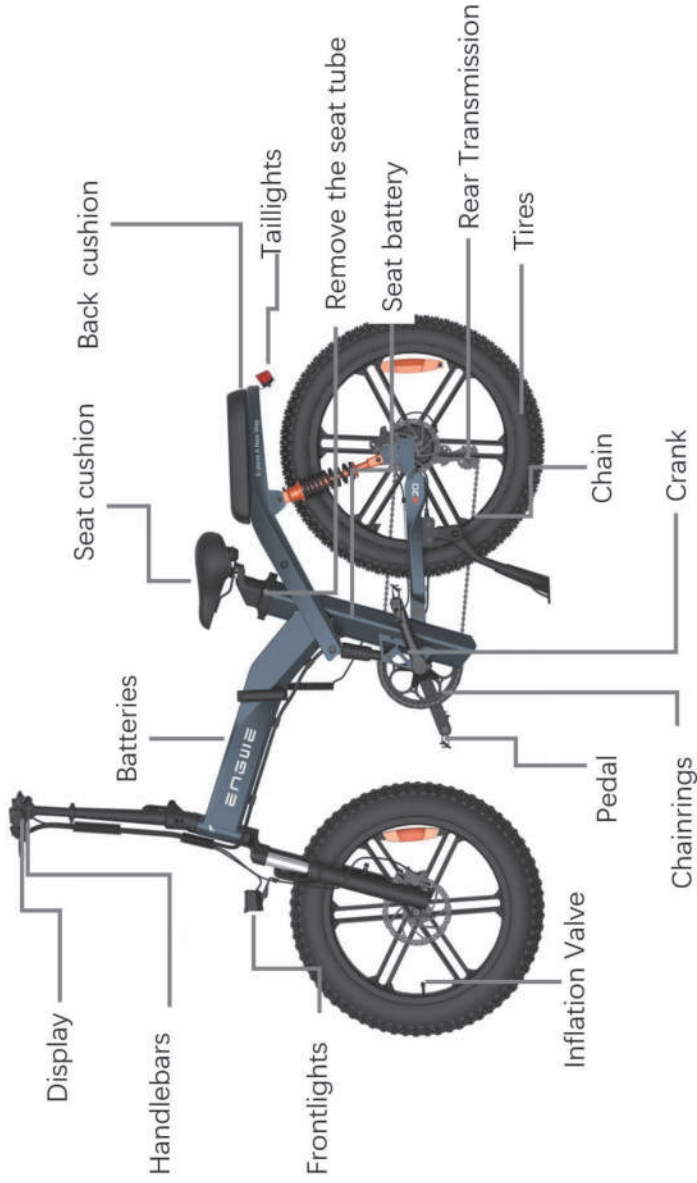

Performance index	Project	X20
Basic Parameters	Vehicle size	67.7*11*44.4 inches
	Wheel Size	20Inches
	Body Material	Aluminum alloy
	Maximum Load	330.6lbs(150KG)
	Vehicle weight	75lbs(34KG)
Main Parameters of the	Maximum Speed	31mph(50km/h)
Whole vehicle	Maximum Gradient	30°
	Rear Derailleur	8-Speed
	Max Range	62 miles(pure electric) / 93 miles (pedal assist)
	Working Temperature	-4-140°F(-20-60°C)
Battery Parameters	Rated Voltage	48V
	Battery Capacity	14.4AH +7.8AH
	Service Life	500 Times
Motor Parameters	Motor Power	750 W
	Motor Type	Brushless Gear Motor
	Maximum Torque	60Nm
Charger Parameters	Input voltage	100-240V
	output voltage	54v
	output current	2A



What's in the Box

- Take out the bike, the seat post, and the toolbox.
- Remove (and recycle) all wrapping material.
- Save the bike box and toolbox for future use.

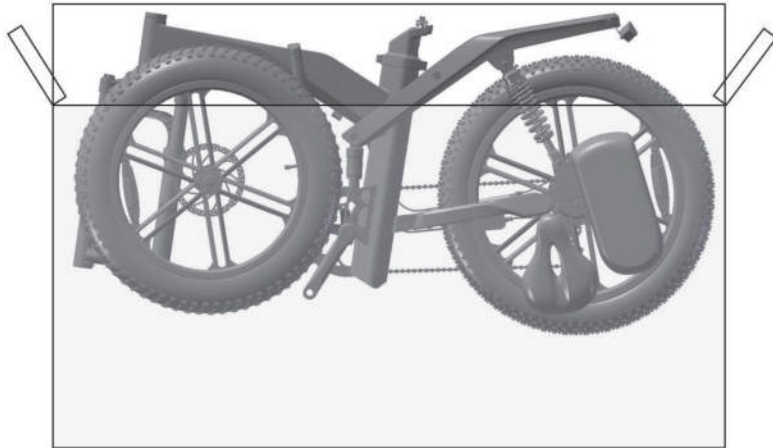

Bike box



Tool box

Tool Box Checklist

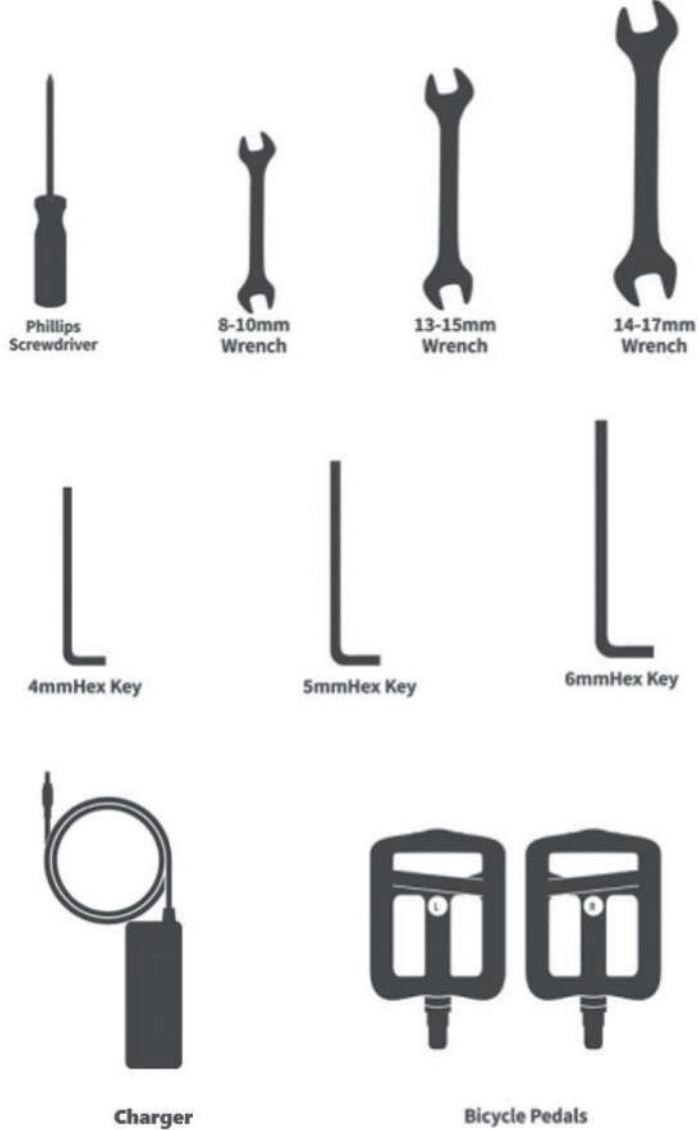

- Take out the front wheel.

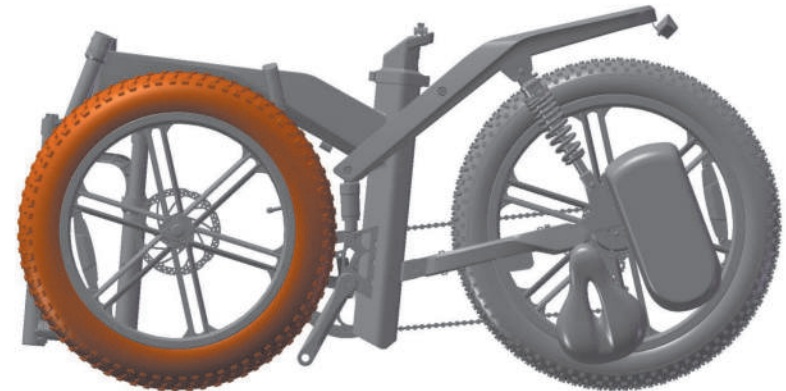

- Remove the protection cap from both sides of the front wheel.





First put the folding seat tube on the head tube, adjust it to a suitable angle, and tighten the screw with a No. 6 wrench.

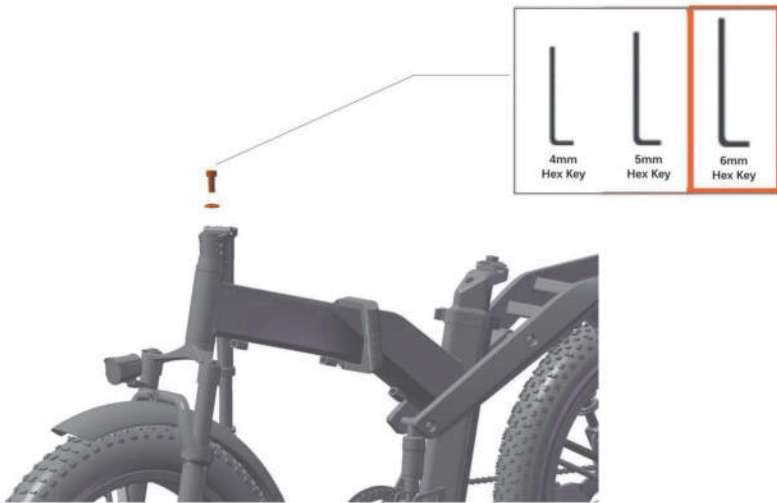

Tighten the screws with a No. 5 wrench.

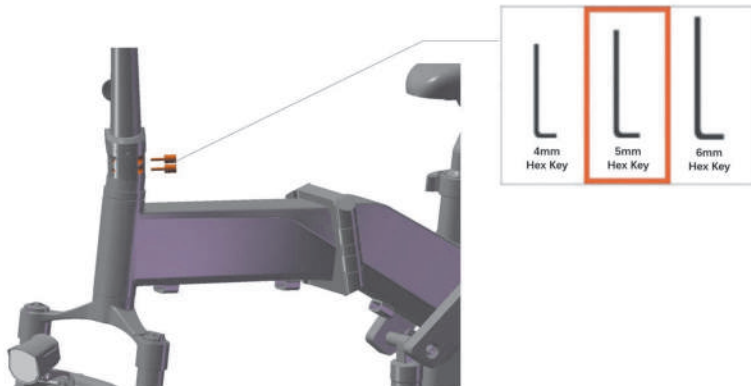

Fix the standpipe, put the handlebar in the appropriate position, and tighten the screw with a No. 5 wrench.





- Take the headlight out of the carton.



- The fixing piece shall be inserted into the mounting hole.
- Align the screwhole, and then insert the screw to tighten it.

- Tighten with screws in the sequence shown in the figure.

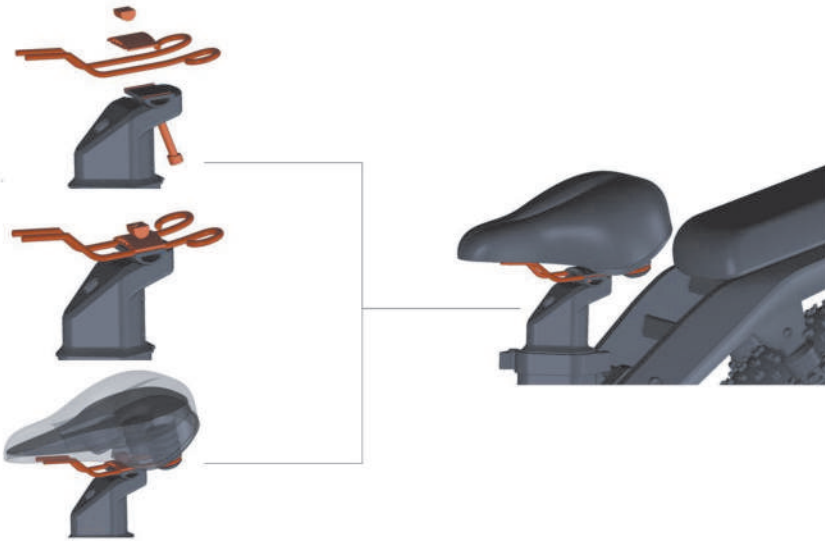

- Push the saddle down and then forward to complete the installation.



- The screws and gaskets shall be installed according to the picture.

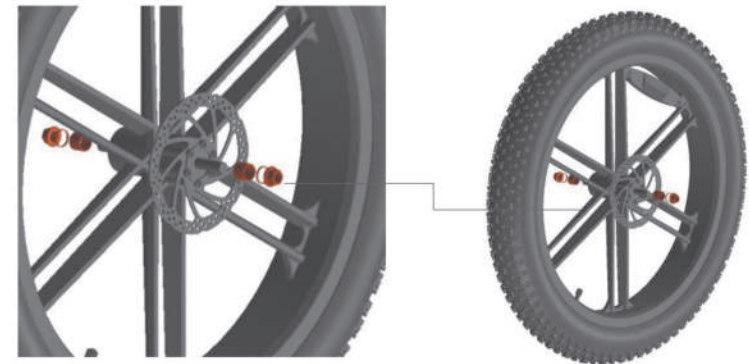

- Clamp the front wheel with the front fork and lock the front wheel screw with a wrench.

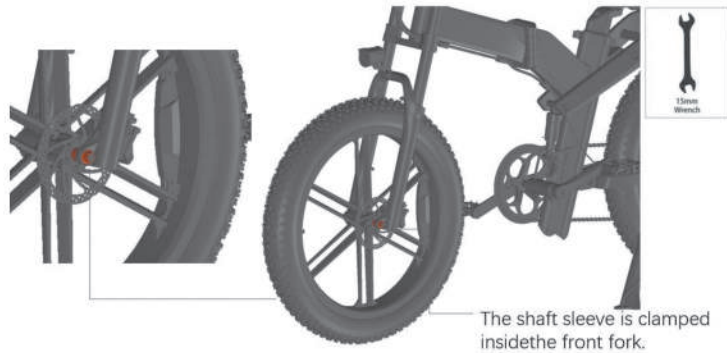

- The pedals are marked with "R"(Right) and "L" (Left). This refers to the two sides of the e-bike. The R pedal goes to the side of the carbon belt, and the L pedal goes to the other side.

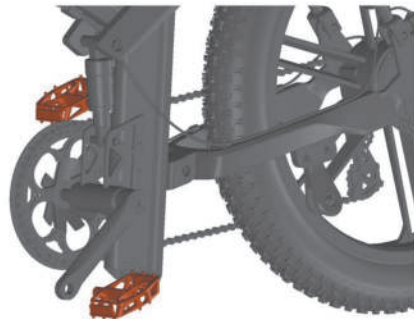

- Manually install the left pedal by turning counterclockwise, and install the right pedal by turning clockwise. Tighten the pedal securely with a 15mm wrench.

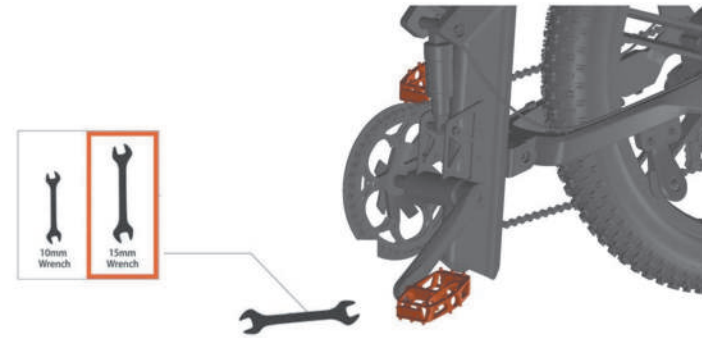

- Fill up the air with the hand pump before riding.

DISPLAY GUIDE

Function overview

The Display provides a variety of functions to meet your riding needs,

including:

- Battery level indicator
- Motor power indicator
- Assist level adjustment and indication
- Speed indicator (including real-time speed, maximum speed, and average speed)
- Distance indicator (including trip distance and ODO)
- Push assistance control and indication
- Headlight control and indication
- Error code indicator
- USB connection indicator (reserved)
- Heart rate indicator (reserved)
- Bluetooth connection indicator (reserved)
- Custom parameter setting (e.g., wheel diameter, speed limit, battery level, assist level, power-on password, controller current limit, etc.)
- Reset function

Buttons Functions

Name	Functions
[Power]	1、 Power on/off
[+]	1、 Parameter adjustment 2、 Menu operation
[-]	1、 Parameter adjustment 2、 Pedestrian mode on/off 3、 Menu operation
[Light]	1、 Light on/off
[i]	1、 Parameters confirm 2、 Long press->Change mode

Riding Interface

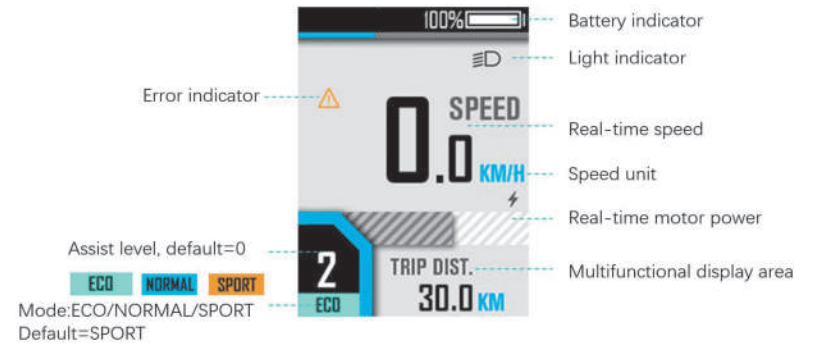

Multifunctional display area : Short press [i] button to change

TOTAL DIST. 3539 KM	TRIP DIST 3539.4 KM	POWER 253 w
AVG SPEED 35.3 KM/H	MAX SPEED 35.3 KM/H	TRIP TIME 1035h 23m

Mode Switch

Press and hold the [i] key for 1s to switch the ECO/NORMAL/SPORT mode.

DISPLAY GUIDE



The switch to SPORT mode needs to be started when the speed is above 15km/h, and the maximum maintenance time of SPORT mode is 3min; After the completion of SPORT, the SPORT mode is frozen and automatically switched to NORMAL mode. It takes 10 minutes to start the SPORT mode again.



Error Code

Common error codes are as follows (Only for reference, depending on other electrical parts of the e-bike):

DISPLAY GUIDE

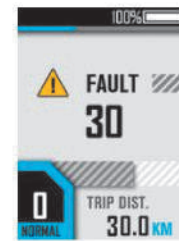

KM55 protocol Error Code	
Error Code	Meaning
21	Current or Mos Error
22	Throttle Error
23	Motor Phase Error
24	Motor Hall Error
25	Brake Error
26	Low-voltage protection
30	Communication Error

User Menu

To enter the user menu, please long-press the [+] and [-] combination buttons for 1s on the riding interface when static. This interface will automatically return to the riding interface when there is no operation for more than the 60s.

- Clear Data

In the "Clear Data" menu interface, select the "Trip Distance" menu item, click the [+] / [-] to switch (the default option is "No"), and click [i] to confirm and automatically return to the previous menu interface.

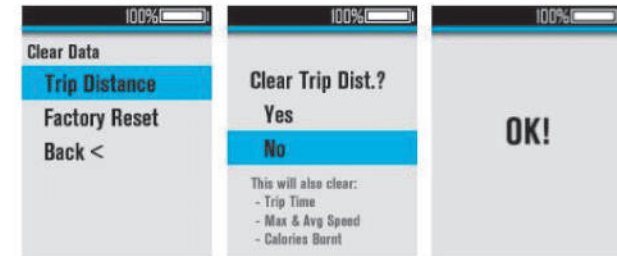

- Factory Reset

In the "Clear Data" menu interface, select the "Factory Reset" menu item, click the [+] / [-] to switch (the default option is "No"), and click the [i] to confirm and automatically return to the previous menu interface. After "Factory Reset", some functions need to be restarted to take effect.

DISPLAY GUIDE

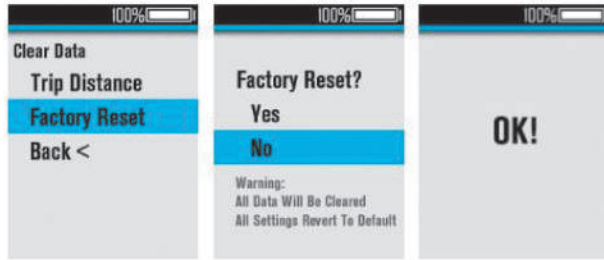

• Set Unit

Select "Set Unit" and click the [i] to enter the submenu, you can select the unit: Select the "Set Unit" menu item, click [i] to enter, and click [+] /[-] to switch the unit. Click [i] to confirm and automatically return to the previous menu interface.

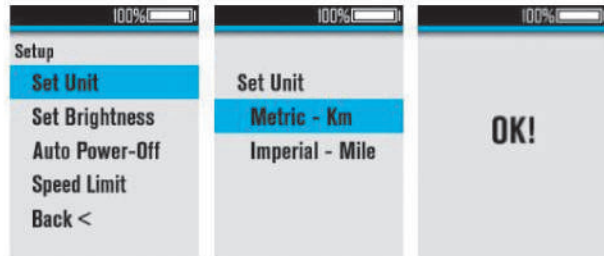

• Set Brightness

Select "Set Brightness" and click [i] to enter the submenu, the adjustment range is Auto, 1-5; Click [i] to confirm and automatically return to the previous menu interface.

DISPLAY GUIDE



• Auto Power-Off

Select "Auto Power-off" and click [i] to enter the submenu, the adjustment range is 0-99(unit: min), 0=Never auto power-off. lick [i] to confirm and automatically return to the previous menu interface.

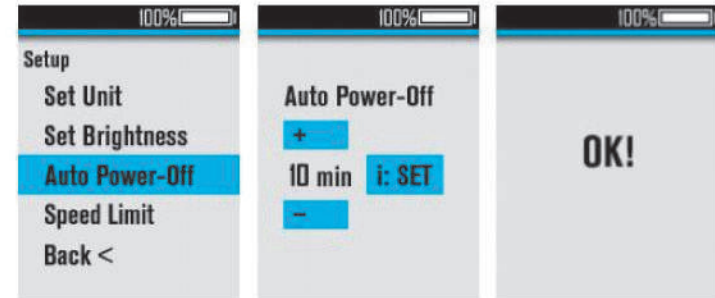

• Speed Limit

Select "Speed Limit" and click [i] to enter the submenu, the adjustment range is 22-50km/h. Click [i] to confirm and automatically return to the previous menu interface.



- Personalization

Click [i] to enter the "Personalization" menu interface, you can set the cruise control (CRU), reverse charging current (ACF), auto headlight (Auto Headlight), and Assist level PWM (Power Set). CRU and ACF are only available for a specific e-bikes.

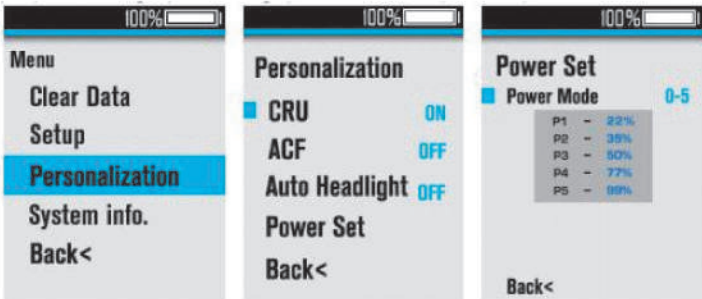

Select "CRU", and press [i] to adjust ON/OFF;

Select "ACF", and press [i] to adjust ON/OFF;

Select "Auto Headlight", and press [i] to adjust ON/OFF;

Select "Power Set", press [i] to enter, and press [i] again to select "Power Mode", click [+]/[-] to switch the assist level range, the adjustment range is 0-3/1-3/0-5/1-5/0-7/1-7/0-9/1-9. Click [i] to confirm and exit, and click [+]/[-] to

change the percentage value of each assist level.

- System Info

Select "System Info" and click [i] to check the version info.

Click [i] to return to the previous menu interface.

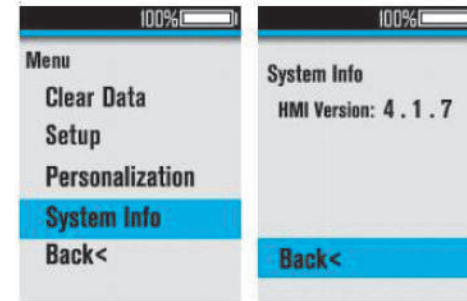

YOUR FIRST RIDE

NOTE: Please be VERY CAREFUL when you are ready to get on your e-bike for the first time because the e-bike moves significantly faster than a regular bicycle in active power-assisted mode. Take your e-bike to an area with a lot of open space before you start. We recommend that you ride your e-bike with the pedal assist off at first, to get familiar with the braking and gear shifting. Then, you can start testing the pedal assist levels incrementally to gain familiarity with the optimal settings for your riding style.

Safety Checks Before Every Ride

- The battery pack must be charged and installed correctly.
- The display must be on and functioning properly.
- The brakes must be working properly.
- Tires must be inflated to the proper psi.
- The front and rear lights must be working properly.
- Cable connections must be secure.

Operating Your New e-Bike

The method to turn on the bike is:

- Press the power button on the left handlebar until the display lights on;
- Ride on the bike and twist the throttle bar or pedal the bike, the bike will move and you can change the power level with control buttons, level 1 is

the slowest and level 5 is the fastest, and level 0 is the human model.

Other Function

- Hand Throttle Control. In the hand throttle mode, the amount of power assist is determined by the throttle switch controlled by your hand. You control the throttle by twisting it from its resting position, the farther the throttle switch is from its resting position, the more power is delivered to the motor to accelerate the e-bike. When you want to slow down, you simply release the throttle and let it return to its resting position, and simultaneously apply the brakes if necessary. You do not need to pedal the e-bike if you use the hand throttle. However, you can pedal while commanding power assist. If you pedal to help the movement, you conserve energy and the charge in the battery will last longer.



SECURITY AND WARNINGS

Before Riding the e-BIKE

Always perform a mechanical inspection before riding an e-bike:

- Hardware is properly secured
- Tires are properly inflated
- Brakes are working properly
- Adjusted and fixed handle
- Front wheels are secure and properly locked

When Riding the e-Bike

- Obey all road rules and local traffic laws.
- Respect motorists, pedestrians, and other cyclists. Do not race or taunt other cyclists.
- Ride cautiously as others may not see you. Do not get too close to other cyclists or vehicles.
- Ride on bike lanes and trails.
- Obey traffic stop signs and signals.
- Use appropriate gestures when turning and parking.
- Do not wear headphones.
- Do not bring adult passengers.
- Do not carry anything that obstructs your view or control of your e-bike.



Avoid riding in the following situations:

- Visibility is poor, such as at dawn, dusk, or in the dark
- bad weather
- Extreme rider fatigue
- E-bike maintenance required

Off-road Riding

- Obey local laws regarding off-road riding.
- Practice riding on easier terrain to enhance your skills.
- Always wear proper safety gear.
- Always ride with a companion in the backcountry.

Riding in the Rain

- Avoid riding in wet weather as much as possible.
- Reduce your speed if you need to ride in wet weather.
- Wet weather can affect the visibility, braking, and traction of an e-bike and affect others sharing the road.
- Accidents increase in wet weather conditions.

Riding at Night



- Riding at night is far more dangerous than riding during the day.
- Be sure to wear reflective clothing.
- Make sure you obey local laws regarding night riding.
- Reflectors are not a substitute for the required lights. Reflectors help others see you by picking up and reflecting cars and street lights. Before riding at night, make sure your reflectors are in good condition. Do not remove the reflectors from the e-bike.
- Always use an adequate lighting system when riding at night or any other time of poor visibility. Riding at night or any other time of poor visibility without adequate lighting systems and reflectors could result in death or serious injury. Equip your e-bike with aftermarket batteries or a generator lighting system if necessary.

Extreme and Aggressive Riding

Electric bike designs have limitations in terms of strength and integrity. Extreme, stunt, and competition riding may exceed these limits. The manufacturer does not recommend these types of rides. Additionally, extreme, stunt, and competition riding increase the risk of death and serious injury.





BATTERY AND MAINTENANCE

Charging Your e-Bike Battery

Follow these steps for charging your e-bike battery from Engwe Bikes:

- Open the cover of the charging port and fold the bicycle;
- Insert the key into the battery, and hold it down until it is screwed clockwise to the end (note: the lock lever is completely retracted into the battery to remove the battery);
- Slide off the battery, the battery is quite heavy, you should be careful not to drop it.

Battery Charging Information

- You can charge the battery while it is installed on the e-bike or after it is removed from the e-bike.
- You should turn off the battery before you charge it.
- The charging time depends on the remaining capacity of the battery. If the battery is fully discharged, it will take 6 hours to fully charge. When the battery is fully charged, the LED on the charger will change from red to green. At this point, you should disconnect the charger.
- Do not leave the charger connected to the battery for a long time after charging is full (keep it connected and charge overnight.)

It is normal for the charger and battery to heat up slightly during charging. If



you notice anything unusual while charging, please stop charging and using the bike and contact Engwe Bikes Product Support for assistance.

Tips for Increasing Range

The bike's range on a single charge will vary widely based on rider, terrain, wind conditions, user input, and additional cargo weight. The table below shows an estimate of the potential range a rider might expect under different conditions.

All tests use:

To get the most range per battery charge, there are a few simple things you can do:

- Ride at a lower PAS level.
- Use lower PAS levels and pedals when climbing hills.
- Pedaling when starting from a standstill.

Battery Recycling

When your battery is no longer usable, dispose of it according to state and federal regulations. State regulations regarding battery disposal vary, so it's important to know and follow your state's regulations. Lithium-ion batteries cannot be placed in standard trash cans.

BATTERY AND MAINTENANCE



Recommended Maintenance Interval

Regular inspection and maintenance are key to ensuring your Engwe bike performs as intended and reducing wear and tear on its systems. The suggested maintenance intervals are for guidance only. Actual wear and service needs will vary with usage conditions. We generally recommend inspections, service, and necessary replacements at the first time or mileage interval in the table below.

Interval	Inspect	Service	Replace
Weekly, 160-321km(100-200mi)	- Check the hardware for proper torque. - Check the drivetrain for proper alignment and function (including chain, cassette, sprockets, and derailleurs).	- Wipe the frame with a damp cloth to clean the frame. - Use the barrel adjusters to tension the derailleur/brake cables if needed.	- Replace any component that has been confirmed by Engwe Bikes Product Support or a certified reputable bicycle mechanic to be damaged

BATTERY AND MAINTENANCE



	- Check the correctness of the wheels and quiet wheel operation (no spoke noise) - Check the condition of the frame for any damage.		beyond repair or damaged.
Monthly, 402-1207km (250-750mi)	- Check brake pad alignment and brake cable tension. - Check that the bike moves correctly, proper derailleurs tension. - Check chain tension.	- Clean and lubricate the drivetrain. - Check crankset and pedal torque. - Clean the brake and shift cables. - If any loose spokes are	- Replace brake and shift cables if necessary. - Replace brake pads if necessary.

BATTERY AND MAINTENANCE



	<ul style="list-style-type: none"> - Check the brake and shifter cables for corrosion or fraying. - Check spoke tension. - Check accessory installation (rack mount bolts, fender hardware, and alignment). 	<ul style="list-style-type: none"> found, adjust and tension the wheel. 	
<p>Every 6 months, 1207-2011km (750-1250mi)</p>	<ul style="list-style-type: none"> - Check the drivetrain (chain, sprockets, freewheel, and derailleur). - Check all 	<ul style="list-style-type: none"> - Tuned by certified standards, well-respected bike mechanics. - Lubricate the bottom bracket. 	<ul style="list-style-type: none"> - Replace the brake pads. - Replace tires if necessary. - Replacement

BATTERY AND MAINTENANCE



	<ul style="list-style-type: none"> cables and housings. 		<ul style="list-style-type: none"> of cables and housings if necessary.
--	--	--	--



TROUBLESHOOTING

Failure Phenomena	Causes of Failure	Solutions
- Can not turn on the e-bike	- Battery is off - The Battery is out of power - Battery aging or damaged - Poor contact with the display line - Failure of computer - Failure of the controller	- Turn on the battery - Fully charge the battery - Replace the battery - Reconnect the display - Replace the computer - Replace the controller
- Pedal assist doesn't work - Gear doesn't work well - Brake doesn't work well - Display doesn't light on	- Failure of the speed sensor - Rear derailleur mismatch - Brake caliper mismatch - Brake Disc is bent - Poor contact with the display line	- Replace the speed sensor - Adjust the rear derailleur - Adjust brake caliper or disc - Reconnect the display line
- Can not adjust the speed - Speed is less than	- The battery's voltage is too low - The throttle governing bar is damaged - Poor contact with the controlling line	- Fully charge the battery - Replace the throttle governing bar - Replace the spring



10km/h	- Spring failure or being locked	
- E-Bike's mileage is inadequate after fully charged	- Inadequate tire pressure - Failure of charger - The battery cannot be fully charged - Failure of the controller - Battery aging or battery damaged - E-Bike has not been well assembled - Too much upgrade road - Strong wind - Bad road - Overweight - Too many braking times - Temperature is too low	- Inflate the tire with appropriate air pressure - Repair the charger - Examine and repair the controller - Replace the controller - Replace the battery - Re-adjust the e-Bike - Boost the e-Bike by manpower - Warm the battery above 0°C(32°F)
- The wheel hub stopped running after switching on the power	-The connection of the battery is loosened - Poor contact of controlling line -The connection of the wheel hub is loose or damaged -The protective board of the battery is broken	- Re-connect the battery - Replace the connection line - Replace the battery's protective board with a new one



LIMITED WARRANTY

This limited warranty only covers the original owner of an electric bike purchased from Engwe online or in-store. The warranty period begins when you receive the e-bike and shall end immediately upon the end of the warranty period or when the e-bike is sold or transferred to another person, and in no event shall the limited warranty applicable to any subsequent owner or owner of the e-bike other assignees.

Accessories	Quality Problem	Warranty Period	Service Content
Motor	The motor will not be able to use	1 year	Free delivery of parts
Accelerator	Natural conditions (such as impact force cannot be used except for damage)	1 year	Free delivery of parts
Controller	Failure occurs under normal use	1 year	Free delivery of parts
Charger	Failure occurs under normal use	1 year	Free delivery of parts
Lithium Battery	Can't charge under normal use	1 year	Free delivery of parts



This Limited Warranty Does Not Cover the:

- Normal wear and tear of any covered components.
- Consumable or normal wear parts (including but not limited to tires, inner tubes, brake pads, cables and housings, handlebars, chains, and spokes).
- Any damage or defect in the warranty component caused by failure to follow the instructions in the electric bicycle owner's manual, acts of God, accident, misuse, neglect, abuse, commercial use, alteration, modification, improper assembly, installation of non-original parts or accessories or incompatibility with electric bikes sold, mishandling, water damage, extreme riding, stunt riding, or improper subsequent maintenance. Any unauthorized servicing or use of unauthorized parts.
- Batteries are not warranted against damage caused by electrical surges, use of an incorrect charger, improper maintenance or other such misuses, normal wear and tear, or water damage.

Dear customer !

Thank you for purchasing ENGWE series products!

Warranty service: Please enter into the official website

<https://engwe-bikes.com/> to view the warranty policy of Engwe.

After purchasing Engwe products, please kindly contact Engwe after-sales

LIMITED

WARRANTY



service for help when there is a quality issue, which means that you can contact customer service of the seller where you buy your e-bike from.

Please provide your order number, purchase interface, videos of the issue.