



KUKitin G2 Pro

USER MANUAL

EN



www.kugookitin.com

KUKIRIN G2 Pro SCOOTER USER MANUAL

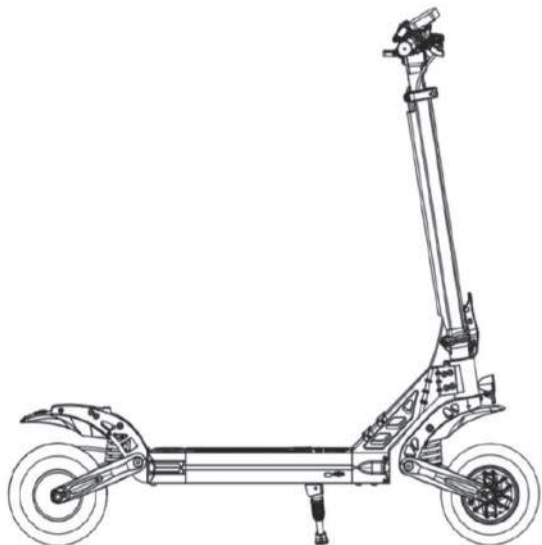

Please read the User Manual before using it-inside including warranty card.

CONTENT

1. PRODUCT & ACCESSORIES	2
2. FUNCTION INSTRODUCTION	3
3. SAFETY NOTIFICATION	4-7
4. PRODUCT DISPLAY	8
5. SCOOTER ASSEMBLE	9
6. FRONT POLE TELESCOPIC	10
7. EXPANDING STEPS	11
8. FOLDING STEPS	12
9. CHARGINHG	13
10. TRANSPORT	13
11. SEAT ASSEMBLE INSTALL PROCEDURE	14
12. SEAT FOLDING STEPS	15
13. SEAT EXPANDING STEPS	16
14. CONTROL SYSTEM STRUCTURE	17
15. OPERATE INSTRUCTIONS	18
16. RIDING INSRUCTIONS	19
17. BATTERY AND CHARGER	20
18. LCD DISPLAY	21
19. STATUS INDICATION	22
20. MAINTENANCE	23
21. ERROR CODE	24
22. SOLUTIONS FOR NORMANAL PROBLEM	25
23. PARAMETER	26
24. AFTER-SALE SERVICE	27
25. WARRANTY CARD	28

PRODUCT VIEW

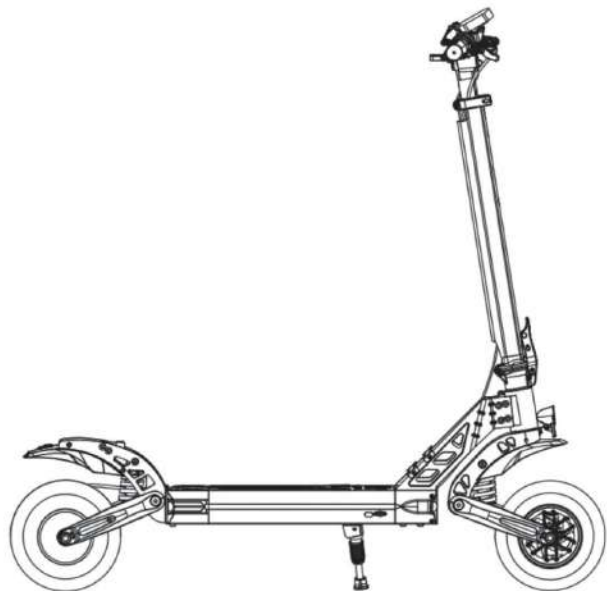

01

1.PRODUCT & ACCESSORIES

Body



Accessories



1.Four-folded page 2.User manual 3.inflator 4.Tool bag 5.Charger 6.Seat 7.Screws

Please carefully check whether the items in the packing case are complete and intact. If there is any missing or damaged, please contact the distributor.

02

2.FUNCTION INTRODUCTION

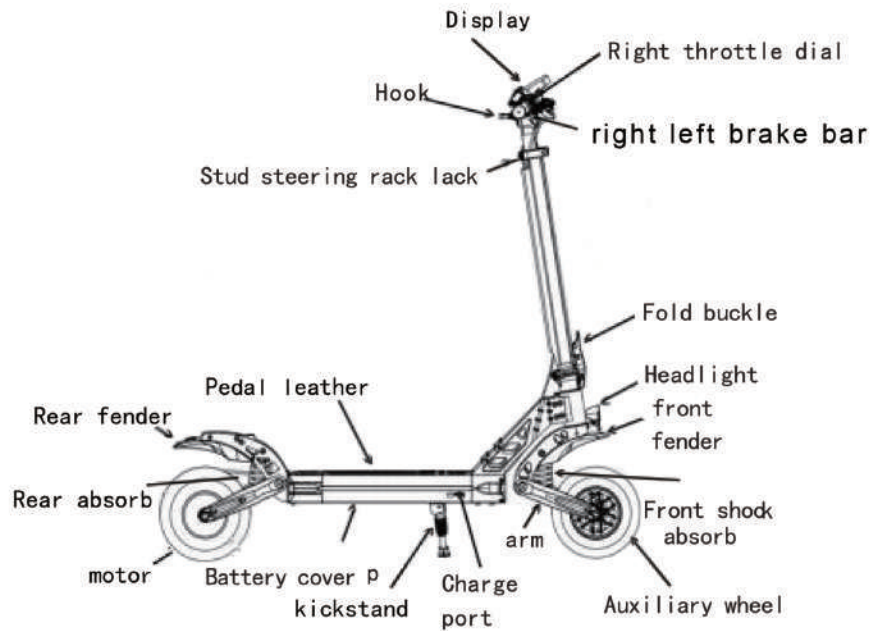

03

3.SAFETY NOTIFICATION

Note: Please read carefully below important safety information before using

1.This scooter just for one adult only, don't ride with two or more

2. Use helmet other safety device during riding.

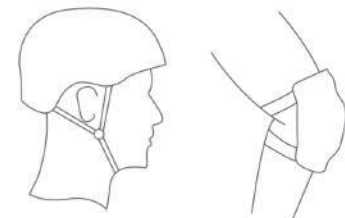

3.Don't ride it on unsafe place or break traffic law place riding this scooter

4. Have a try riding on a empty place before riding on the road.

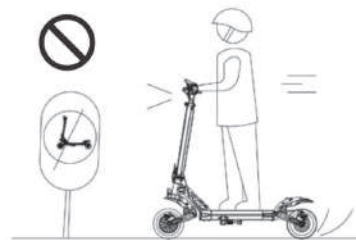

04

5. Don't make any dangerous action or riding with one hand during riding process, keep your feet on the scooter.

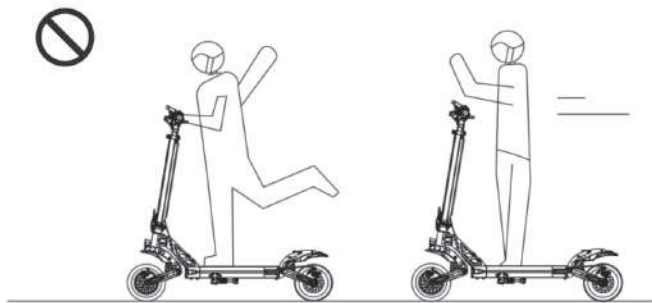

6. For your safety, please limit the speed within 25km/h. please avoid using it at night, if need riding, please limit the speed within 15km/h and turn on the light.

7. Please don't use the scooter when the temperature is lower than -5°C .

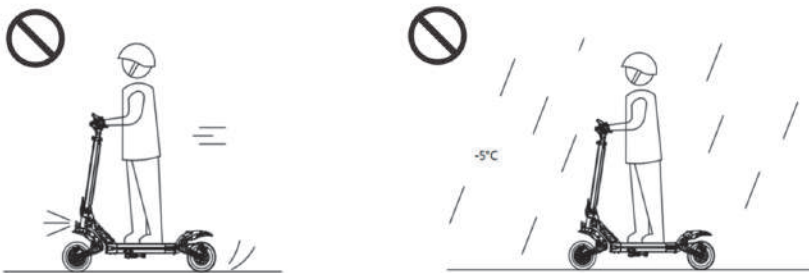

8. Please reduce the speed and driving carefully or get off the scooter to pass by Rugged road.

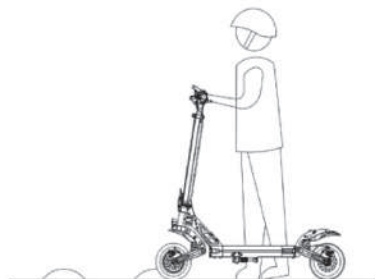

9. Don't ride it on the wet ground with ice or oil.

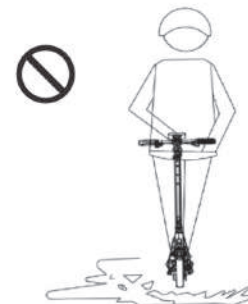

10. In order to protect battery or other electricity parts, please don't put scooter into water with height more than 4cm.



11. In order to avoid unnecessary hurt, please don't use it when the weather is bad, such as heavy raining and heavy snowing.



12. Users shall use the product in accordance with the relevant manual, not exceed the product can bear the load of use
13. Please avoid using and storage scooter in the too-high or low temperature, please keep it away from flammable substance, and cause fire in accident condition.

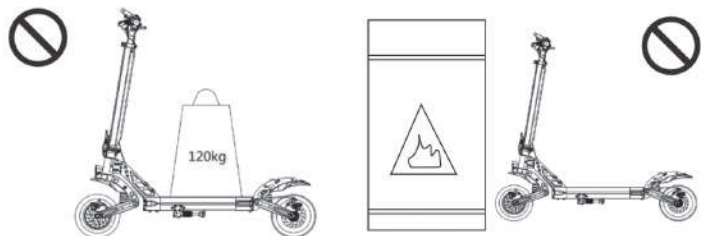

14. Please ride on the smooth roads and no potholes places.

15. User shall strictly follow the traffic road regulation when riding.

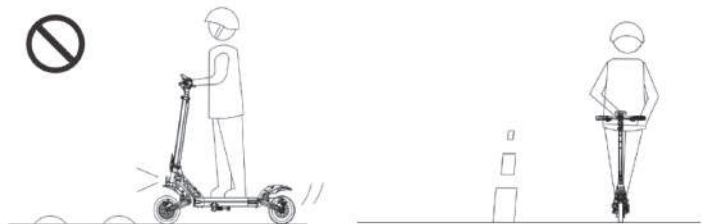

4.PRODUCT DISPLAY



Expanding status

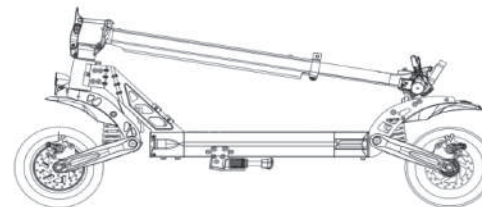

Folding status

5.COOTER ASSEMBLE

1. Dial out the hook makes it remove from the hook holder.and then stand up the scooter front stud.

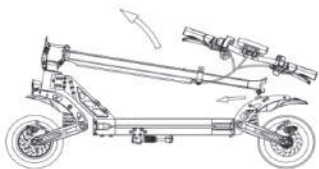

3. Flip the instrument forward, revealing the instrument screw hole and put the screws in it.tighten it by wrench, and then flip instrument backward,tighten screws by wrench.



2. Pull upward the folding buckle, lock tightly folder.



4. After completing assemble, check whether the light, motor, brake is work normally,whether the screws is tightened.



6.FRONT POLE TELESOPIC

1. Gear introduction

Front pole telescopic gear divide into 3 gears, is low gear,middle gear,hi gh gear.

2. Gear switch way

First release the steering rack lock,press the marble with thumbs, and press the vertical bar down with other hand,when that locate the right height,it realizes the function of downward adjustment. On the contrary,it realizes the function of upward adjustment.

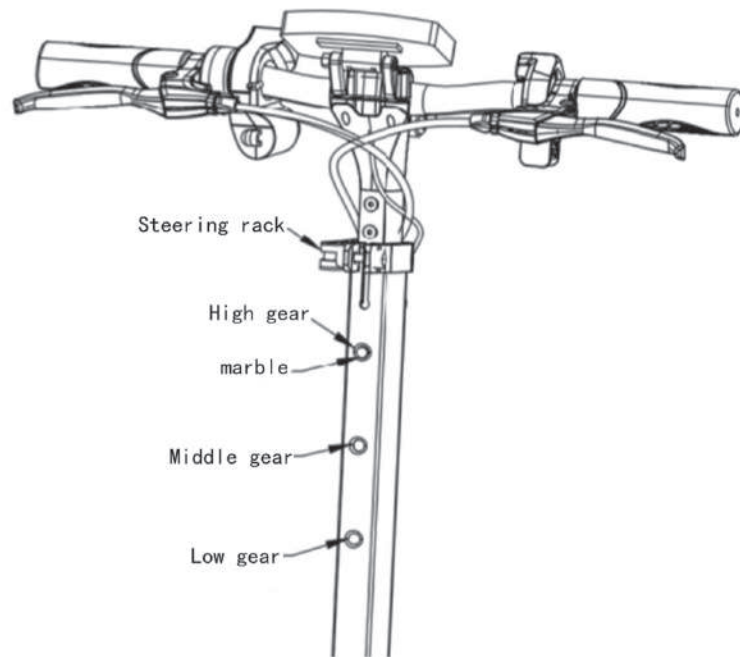

7.EXPAND STEPS

1. Pull the hook out with one hand
And remove the hook from the hook
holder.

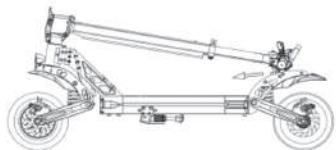

2. The other hand lifted the front pole

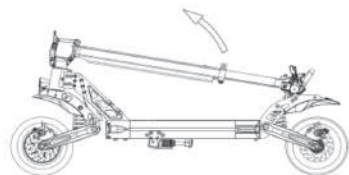

3. Dial up the folding buckle,
lock the folder.



4. Check whether the scooter body screws
have Situation of fall off and loosen,
and then riding.



8.FOLDING STEP

Note: For your safe, please power off before folding, and then operate as
below picture procedure.

1. lifting the folding latch up

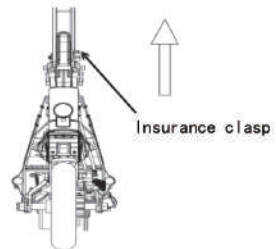

2. Then pull it aside

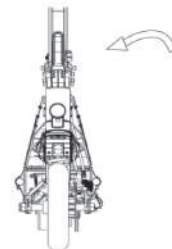

3. After folding latch move forward,
slowly put down the the front stud.



4. Adjust the scooter body
stud, Insert the hook into slot

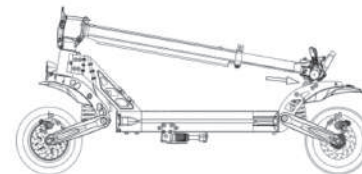

9.CHARGING

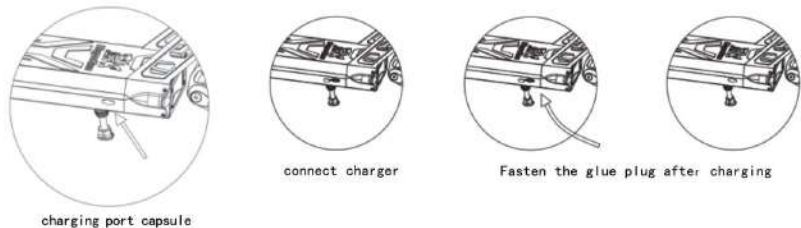

1. Open the charging port waterproof rubber, insert the charger into the charging port,
2. Insert another plug of the charger into the power supply,
3. When the indicator is red, it mean the battery is charging, when the indicator turn to green, it means battery is full of battery.

10.TRANSPORT



After folding the scooter, you can transport it by single or double head,

11.SEAT ASSEMBLE PROCEDURE

1. Attach the seat bracket to the battery panel with four bolts

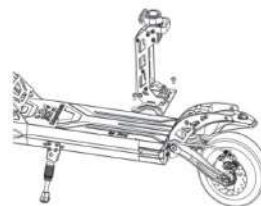

2. After the rack is fixed, open the latch for the seat

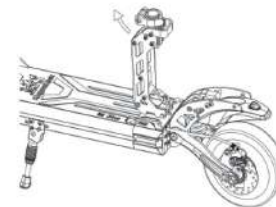

- 3 Insert the seat into slot

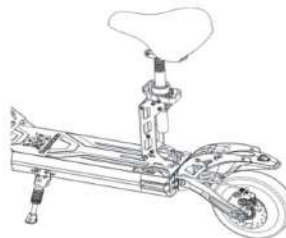

- 4 Turn the seat in the right direction and lock it



12. SEAT FOLDING STEP

1. Loosen the latch by pulling the seat back down as show in below picture



3. After pressing the lock pedal to bottom, slowly lower down the seat.



2. Press the lock pedal as show in below picture



13. SEAT EXPAND STEPS

1. Press down the seat axis, meanwhile stand up the seat bracket.



- 3 Shake the seat to make sure it fits into the slots



2. After standing up the seat bracket fully, Loosen the seat axis, fits that into slot.



4. Pull up the seat latch and lock tightly.



14.Control System Structure

- 1.Handlebar cover
- 2.Left brake lever
- 3.Handlebar tube
- 4.Display
- 5.Right brake lever
- 6.Headlight switch
- 7.Electric door lock
- 8.Throttle

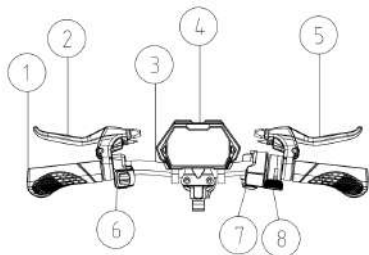

GE Pro Button function

- 1.Insert the key,Turn the key to the right to power on.
- 2.Press and hold the function switch button to switch the machine on and off.
- 3.Short press the function switch button once after starting the scooter to switch gears, divided into three gears
- 4.After power on, short press the function switching button three times in a row to enter the menu setting interface, the meter will display P1, P2, P3, P4, P6, P7, P8, Pa, Pb, Pc. P1: km/mile selection setting, default km P2: Voltage level setting: 36V/48/52/60V/72V P3: Wheel diameter: unit, inch; can be set to 080-160 (080 means 8 inches, 100 means 10 inches, and so on), each time increases by 5 P4 : Number of magnetic poles for speed measurement: Range: 1-100, default 30 P5: Cruise selection: 0 means no cruise, 1 means cruise. When the cruise is not turned on, the cruise icon is off; when the cruise is turned on, the cruise icon flashes; after 8S enters the cruise, the cruise icon flashes; the default is not cruise P6: zero start, non-zero start setting, 0: zero start ; 1: non-zero start, Show boot mode when booting up(zero start will not display the icon, non-zero start will display NON); after power on,after power on, press the accelerator to start directly in zero start mode;In non-zero start mode, you need to slide the car above 5KM/h and press the accelerator to start. P7: speed limit setting: range 0-100 percent speed limit P8: sleep time setting: 0, no sleep; other numbers are Sleep time, range: 1-60; unit minutes, default 5 minutes ,PA :Start force setting: 1-5, 1 minimum , 5 maximum PB: Brake force setting: 1-5, 1--20%, 2-35%, 3-50%, 4-70%, 5-100%.When P1 is displayed, 0-km or 1-mile will be displayed below, indicating the optional setting of km/mile; long press the power button for 3 seconds, the value will flash; at this time, short press the power button to select 1-mile or 0- km; when 0-km is displayed, select km, and Km/h will be displayed; when 1-mile is displayed, select mile, and mile will be displayed; then long press the power button to exit, and select other parameters for debugging; if no operation is performed for 8 seconds Automatically exit the parameter setting (other parameter settings are the same); after entering the menu setting, if the current parameter does not need to be modified, press the button once and switch to the next parameter setting interface, such as the current P1, if you do not need to modify the setting If P1 is modified, it will switch to P2 after a short press of the button.

15.OPERATE INSTRUCTION

1.POWER SWITCH

Turn right the ignition key to turn on the power, Turn left the ignition key to turn off the power

2.GEAR SETTING

Under the power on status,click the power button switch the gear.The range:1st gear(ECO) 、 2nd(D) 、 3rd(S) (full speed).

3.SPEED CONTROL MODE

Non-zero start:when the scooter slide speed over 3km/h that accelerator can start.Press down the right dial throttle,the range of speed is 1-45KM/H.

Zero start:Don't need slide in advance,pres down the right dial throttle directly.the range of speed is 1-45KM/H.

4.BRAKE CONTROL

Pull the brake handle with your left hand and start the E- brake. The greater the pull force, the greater the brake force.

5.LED FRONT LIGHT SWITCH

Click headlight switch to open headlight ,left right side light and taillight.

6.CRUISE CONTROL

Cruise control function is not set in the initial setting of scooter. If you need to use this function, please refer to (button function description). When cruise control function is enabled, cruise control function will be automatically enabled when the vehicle runs at the set speed. After starting cruise control, release the thumb accelerator and the scooter will move forward automatically at an average speed. If need to cancel cruise control, pull the left hand brake and start the e-brake. If you want to disable cruise control function, please refer to (button function description).

7.ZERO START MODE

Stand on the ground with one foot,another foot on the pedal.slowly press right throttle.after the scooter moving smoothly,stand firmly with both feet on the pedal,the control speed is (1-45km/h)

16.RIDING INSTRUCTION

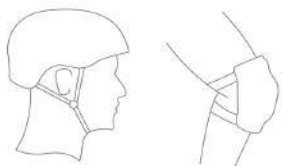

Riding prepare

- 1.Select one place that suitable for riding.
- 2.Expand the product in accordance with the expand instruction and wear guard tool.

1. Turn the key to the right to power on.
- 2.Put one foot on the pedal.
3. push with the second foot and gently press the throttle level to gain speed. put the second foot on pedal.
- 4.In an emergency, pull the left brake handle as well as the right hand to stop the car faster.
- 5.In normal condition,Pull the left brake handle with your left hand, and the car will power off and brake immediately. The larger the pull Angle, the greater the braking force.

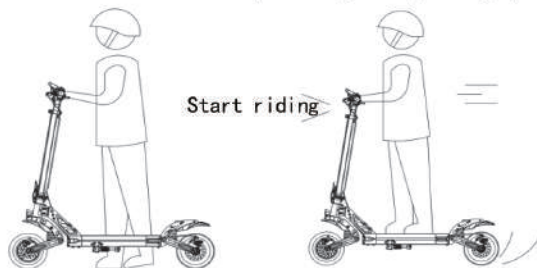

Note: For your riding safety, **G2 Pro** remain the Non-zero start function,select Non-zero start .scooter need slide forward for some distance, and then can use accelerate function.

17.BATTERY AND CHARGER

Every KuKirin **G2 Pro** equipped with Lithium battery and special intelligent charger.Every scooter and relevant accessories special number,please don't use other charger.If cause damage of battery or charger,KugooKirin not responsible for this duty.

1. BATTERY



G2 Pro electric scooter equipped Lithium battery at least change 800 times, general can up to 1000 times innormal use. Lithium battery maybe occur dangerous when charging, please charging outdoor.

2. CHARGER

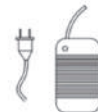

The special charger provided by KugooKirin have charging protection function, when battery is full of power well automatically cut off.Charging time is about 7-8 hours.Damageof battery by abnormal factors is not covered by the warranty policy.

18.LCD

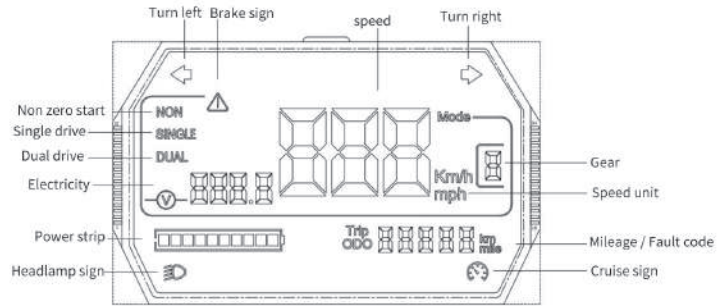

19.STATUS INDICATION

Headlight status indicator:

open	close
When the headlight setting is on, the indicator is steady on always	When the headlight setting is off, the indicator is off.

Three gear notification:

First gear	Second gear	Third gear
First gear indicator is on (ECO)	Second gear indicator is on (D)	Third gear indicator is on (S)

20.MAINTENANCE

LUBRICATION

Folded places Lubrication need to be few lubricating oil per 6 months,check the scooter per 3 months,to ensure all screws fits well.If the screws is loosen,please screw tightly.

BATTERY

When you got the KugooKirin electric scooter first time,please charge the battery fully before using.The battery can be charged at any time,to in order to ensure the battery have power,during that time charger not have any damage .Please charge the batter per 3 months if stop using.

STORAGE

Don' t put the scooter under the sunshine or other damp place for a long time.Keep the scooter surface clean usually.

21.ERROR CODE

Have warning light flicking,and display the code as following

E01 :Motor Hall malfunction

E02 :Throttle malfunction

E03 :Motor hall or throttle malfunction.

E04 :Battery under-voltage malfunction

E05 :Motor hall or battery malfunction

E06 :Throttle or battery malfunction

E07 :Motor hall or throttle or battery malfunction

E08 :motor is disconnect

E09 :Motor malfunction or contact disconnect

E10 :Controller malfunction

E11 :Motor or controller malfunction

E13 :Controller or Motor throttle malfunction

E20 :correspondent malfunction

E30 :Controller or correspondent malfunction

E31 :Controller or correspondent or motor fault

E40 :Brake malfunction

E50 :Controller or brake malfunction

E60 :Correspondent or brake malfunction

E70 :Controller or correspondent or brake

22.SOLUTIONS FOR NORMANAL PROBLEM

When the scooter occurs the problem,please refer to following way

to solve it:

01 Display screen is black

Reason:Expose under the sun too long time.

Solution:Return to normal after putting it in the dark a period of time

02 The digits shows on the display screen is not in accordance with the actual information

Reason:Parameter setting is incorrect or lost

Solution:Long press the power button to power off,then press power button to restart the scooter.

03 Digits is indistinct

Reason:Bad connection for battery or weak battery.

Solution:Switch off the power and restart it,if the problem still happen,pls contact distributor.

04 Please check whether following steps finished or not if the scooter can't work.

A. Power is on or not

B. Check the battery has electricity or not through display screen.

C. Left brake&right brake on original position or not.

D. All insert pole and connecting pole connected correctly or not.

If following above steps to complete fully,the scooter still can't work,please to contact the distributor.

23.PARAMETER

Product name	KuKirin G2 Pro electric scooter	
Product model	KuKirin G2 Pro	
Size	After folding: length*width*height	1187x620x560mm
	After expanding:length*width*height	1187x620x1315mm
Main parameter	Max speed	≤45 KM/H
	Full of power mileage	≤55 KM (depend on environment, angle, speed, driving habitat and so on)
	Max climbing	20°
	Tire	9 Inch rubber tire
	Shock absorption system	Front spring+rear spring
	Waterproof grade	IP54
	Brake system	E-brake+disc brake
	LCD display	Speed, mileage, gear, watt, power, turn mark, headlight open mark
	Light system	LED Highlight headlight
Main parameter	Charger rated input voltage	100-240V
	Lithium battery	48V15AH
	Charging time	About 7-8 hours
Status	Max load	120KG
Weight	Net weight	26.7KG

24.AFTER-SALE SERVICE

This product since you bought in the warranty period, in the normal use of the situation after we confirm the quality of the failure and damage, we will be free of charge for you to repair, replace or return. The warranty period starts from the first purchase of the product and is subject to the date of invoice receipt.

The following damage or malfunction circumstances are not in the scope of above guarantee :

1、 Misuse, abuse or improper transportation, maintenance or storage, including but not limited to use, storage or maintenance under improper temperature, humidity or other improper environmental conditions(2、 Force majeure, accidents and other uncontrollable causes(3.Unauthorized by KugooKirin repair or demolition of the company's unauthorized personnel(4.Use in a manner that violates the product instructions(5.The accumulated mileage of the scooter has exceeded 2,000 kilometers. Normal wear and tear or aging during the use of the product is not covered by the warranty. If the original identification label of the product is changed or damaged, this warranty will be void.

Warranty content	Warranty time
Controller, display and motor	Half of year
Lithium battery, protect plate and charger	Half of year
Scooter body, brake assembly, folding assembly, body bar, front fork, control	One year
Brake system, Thumb accelerator	One year

Note:Tire, headlight assembly, instrument cover, handle cover, fender, rear taillight, decorative cover, foot stand, charging port seat and other vulnerable accessories are not covered by the warranty policy.

25.WARRANTY CARD

When need to repair the scooter,Please fill in the following information completely and clearly.

User Information	Name		E-mail	
	Address			
	Phone Number			
Product Information	Product Name		Sale Date	
	Product Model		Invoice NO.	
Distributor Information	Company Name		Phone Number	
	Address		Zip Code	