

*Before your first operation, please read the user manual carefully!

Contents

1. Note
2. Warning
3. Diagram
4. Package List
5. Assembly Guide
6. LCD Display Guide
7. Maintenance
8. Troubleshooting

1. Note

Before your first ride, it is important for you to know your new e-bike well, so that you can get the best performance, comfort, enjoyment and safety from it during your ride. To understand the new bicycle and the correct operation, you should first read the manual carefully.

Second, it is significant to take your first ride under a safe and controlled circumstance, like staying away from cars, obstacles and other cyclists.

Third, bicycles are vehicles with certain risks. Please follow the traffic rules during cycling. It's better to learn the local traffic rules about riding an e-bike on public roads before your first ride in case you violate the regulations. For your own safety, never forget to put on a qualified helmet before you get on the e-bike.

Fourth, the electric bike is supplied without basic mandatory equipment, which may vary from place to place. Therefore, if you intend to use the e-bike on public roads, it's necessary to equip the bike with the basic mandatory equipment, in accordance with the relevant laws and regulations.

In addition, this product is designed for your personal use. Do not use it for commercial or other purposes.

Last, keep this manual safe for reference.

2. Warning

Before each charge, check the charger, cable and plug. If there is any damage, do not use the charger.

Before riding, check the tire pressure and check whether the wheels and handlebar are installed correctly and tightly.

Before riding, check whether the headlights are securely fastened in the correct position, clean and not covered by anything. Damaged reflectors must be replaced.

Besides, if the seat post in the seat tube is not inserted deep enough to reach the minimum insertion mark, the seat post may break. Check whether it is inserted deeper than the minimum insertion depth. When braking on a wet road, the braking distance is usually longer than on a dry road. Therefore, brake earlier for a safer stop.

When you have to brake urgently, please hit the right hand brake first to stop the rear wheel, and then hit the left hand brake, especially when you brake at a high speed. If the front wheel stops suddenly while the rear wheel is still cycling at a high speed, you may fall over and get hurt. So please ride it carefully.

Furthermore, avoid puddles, wet mud, swamps, water, snow or ice. Try not to use the e-bike on a rainy, stormy or snowy day. If the bicycle's electric parts (control unit, engine and battery) get damp, wet or soaked, it will cause irreversible damage, or even a battery explosion.

This product can only be used by one adult at a time. Do not carry any extra passengers.

This vehicle is not a toy. Same as other vehicles, it is possible to fall, crash or encounter other dangerous situations. Please don't offer your e-bike to anyone that doesn't know how to use it correctly. If you let anyone else ride your bike, it will be your responsibility to ensure that all riders understand all warnings, cautions, instructions and safety precautions, and to ensure that they are able to use this product safely and responsibly and protect themselves and others from injury.

Product function illustration (Model:FM8)

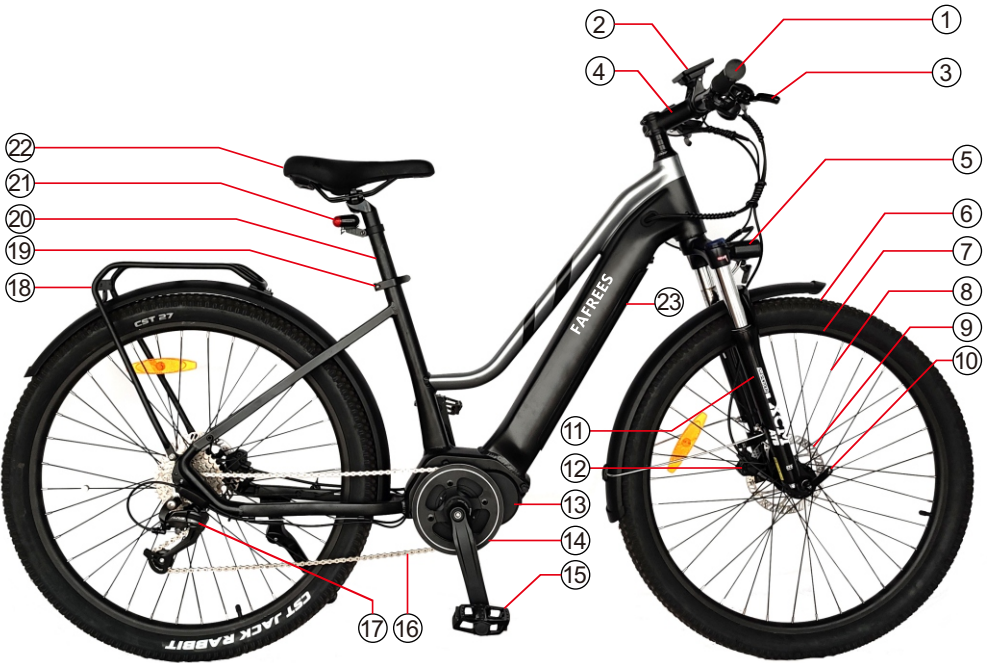

Figure 1 (Bicycle Diagram)



Figure 2 (Left side of the frame)

- | | |
|-------------------------------|-------------------------------|
| ① Handlebar | ⑭ Chainwheel |
| ② Meter display | ⑮ Pedal |
| ③ Brake | ⑯ Chain |
| ④ Stem | ⑰ Rear derailleur |
| ⑤ Headlight | ⑱ Quick release of seat tube |
| ⑥ Tyre | ⑲ Quick release of front fork |
| ⑦ Rim | ⑳ Seat tube |
| ⑧ Spoke | ㉑ Rear reflector |
| ⑨ Brake disc | ㉒ Saddle |
| ⑩ Quick release of front fork | ㉓ Lithium battery |
| ⑪ Front fork | ㉔ Battery buckle knob |
| ⑫ Disc brake | ㉕ Battery lock key hole |
| ⑬ Motor | ㉖ Charging port |



Figure 3 (Handlebar)

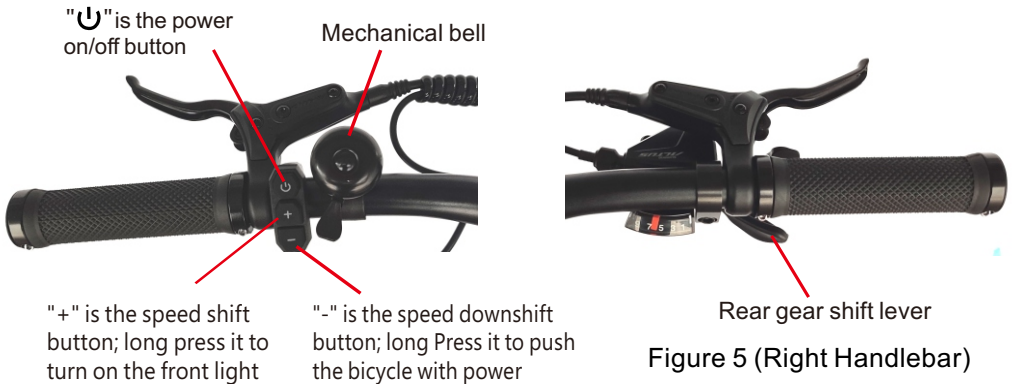

Figure 4 (Left Handlebar)

Figure 5 (Right Handlebar)

Function introduction:

1. Charging: Refer to item 26 of Figure 2, the charging hole can be seen on the left side of the battery in the frame, and it can be charged by connecting the charger. When the battery is full and the charger indicator turns from red to yellow-green, it means it is fully charged.
2. Turn on/off: refer to Figure 4 and press and hold the "⏻" button to turn on/off the power of the display.
3. Display: The display screen lights up after power on, displaying information such as power, speed, motor speed, mileage, etc. The power speed is initially 0. Press the "+" and "-" buttons to increase and decrease the speed of power-assisted mode.
4. Headlight : Refer to Figure 4, long press the "+" button to turn on/off the front light.
5. Power-assisted mode: power-assisted riding, step on the pedals of the bicycle, and automatically start electric power after a certain speed. If you don't need assistance, you can turn off the power of the display.
6. Speed transmission: Refer to Figures 5, when the bicycle is running, you can change the mechanical speed by flipping the shift levers.

How to take out the battery:

1. Turn the key all the way to the left to unlock it, as shown in Figure 6.
2. Hold the lower tube of the frame with your right hand and hold the battery with your thumb to prevent it from falling, as shown in Fig. 7. Then rotate the battery buckle knob with your left hand, and the battery will pop down, and you can take out the battery.
3. After the battery is taken out, the charger can also be connected separately for charging. The charging port is on the right side, as shown in Fig. 8.



Figure 6



Figure 7

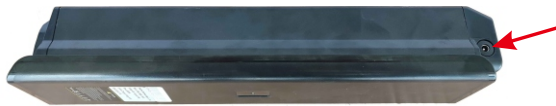

Figure 8

4 . Package List

Eleglide E-bike x 1	User Manual x 1	Charger x 1
Pedal x 2	Tool Kit x 1	Headlight x 1
Spoke Reflector x 2	Taillight x 1	LCD Display x 1
Key x 2		

5. Assembly

Step 1 Install The Handlebar

- Take out the bike and make it stand up.
- Open the clip by loosening the screws on it.
- Place the handlebar in the right position and make sure the clip is in the middle of the bar.
- Lock the clip by tightening the screws.

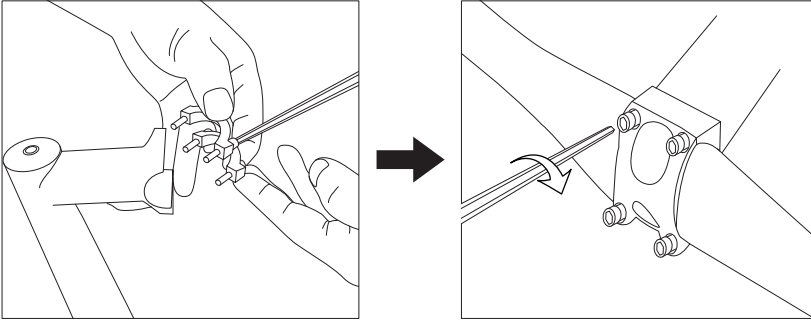

Step 2 Install The Front Wheel

- Put the bike upside down and remove the temporary protected bar by loosening the nut on it.
- Insert the front wheel into the fork dropouts and make sure the wheel is fully seated.
- Remove the nut and one spring on the quick release.
- Slide the quick release through the hub from the opposite side of the brake disc.
- Slide the spring into the hub and tighten the nut to fix the quick release.

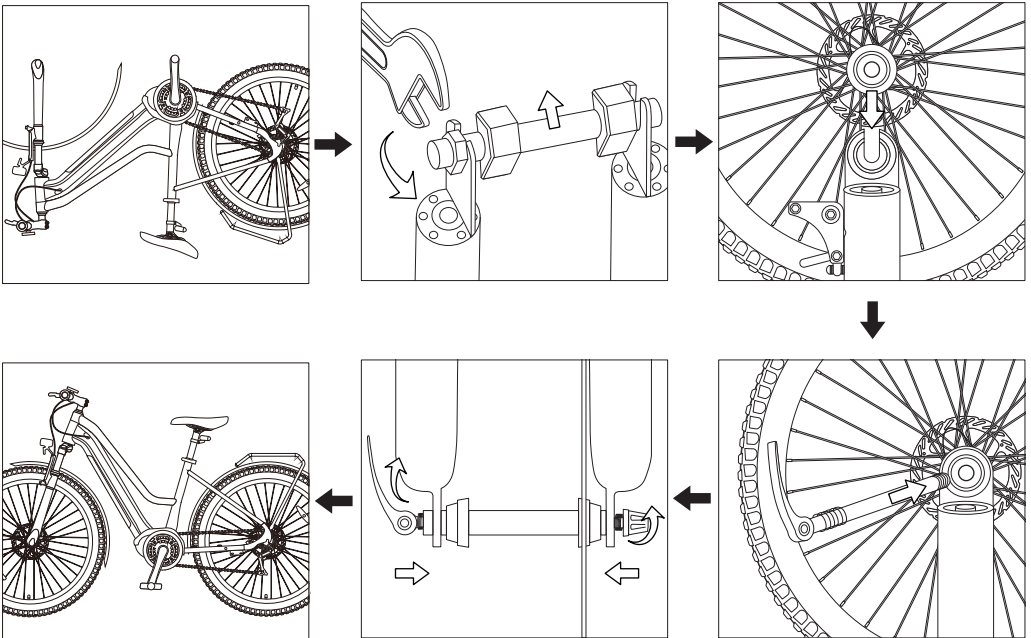

Step 3 Fix The Headset

A) Adjust the headset of the bike to the right position.

B) Tighten the headset with the M4/M5 socket head wrench.

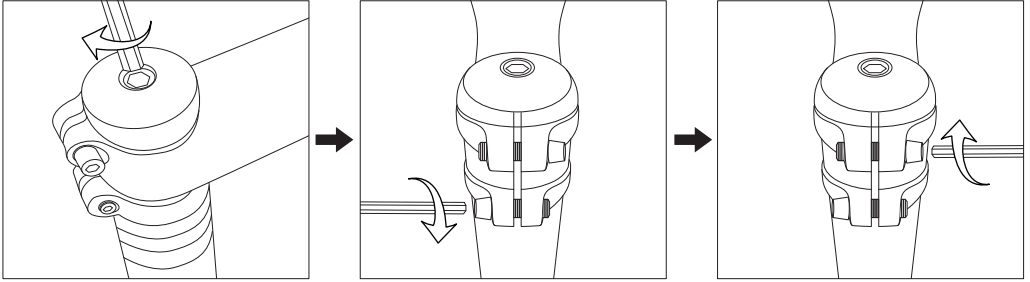

Step 4 Install The Headlight

A) Place the headlight in the right position.

B) Fix the light by tightening the screw with the M4 socket head wrench

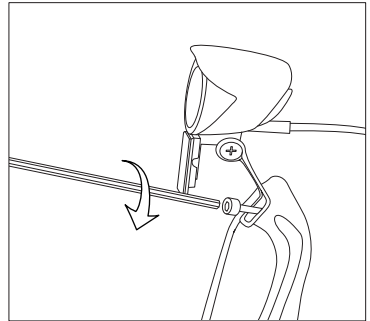

Step 5 Install The Pedals

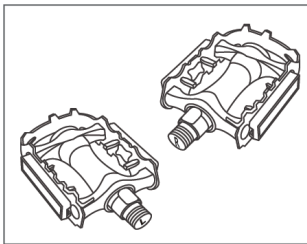

Pedals

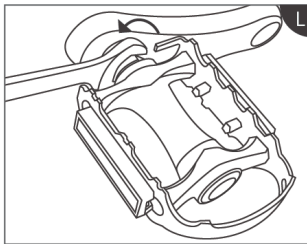

Left

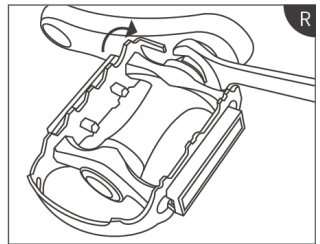

Right

Step 6 Install The LCD Display

- A) To make it easy to install, disassemble one of the supports of the display first with the M3 socket head wrench.
- B) Slightly open another support to get the display stuck on the handlebar.
- C) Slightly open the disassembled support and buckle it on the handlebar. Fix it with the M3 socket head wrench.
- D) Fix the display in the middle of the handlebar with the M3 socket head wrench.
- E) Open the clip of the display button and buckle it on the handlebar. And use the M2.5 hex wrench to tighten the clip and fix the button.
- F) Connect the display cable with the power cord.

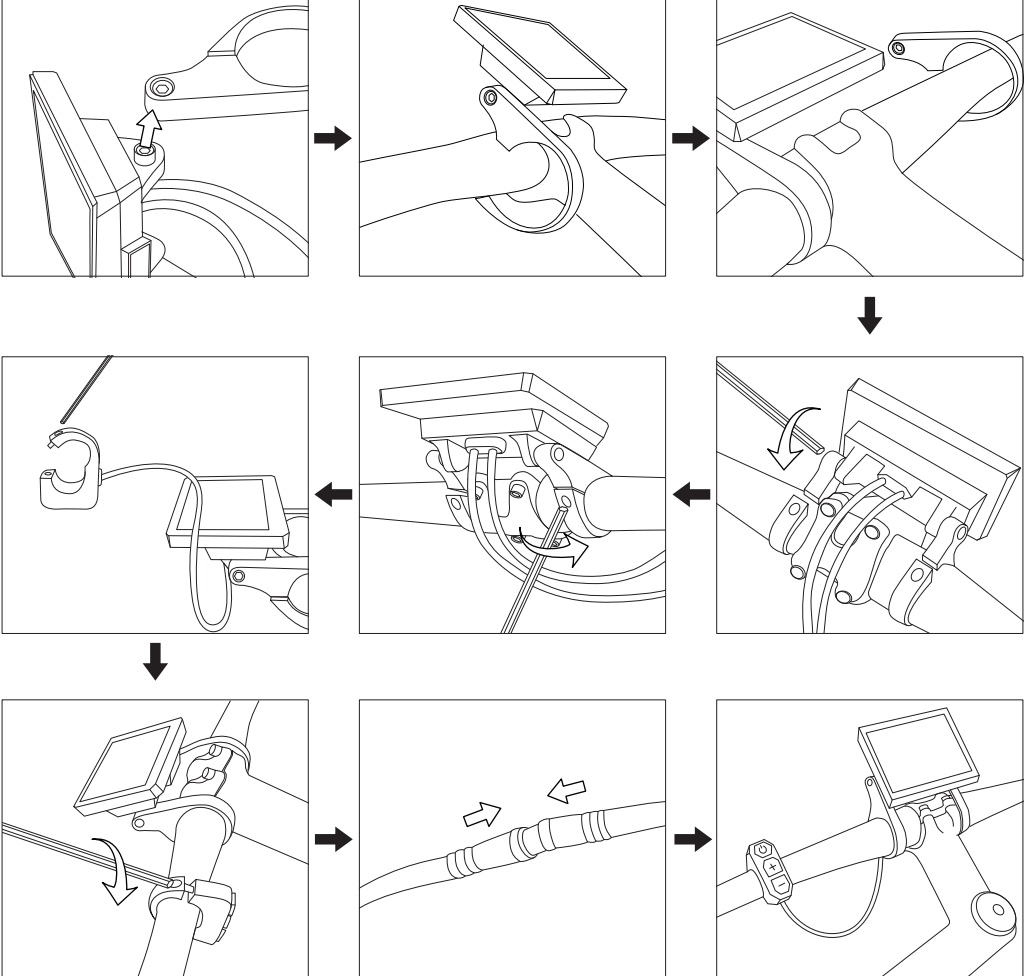

Note: don't overtighten screws when you install the display. Or it will cause permanent damage to it. The display can be mounted firmly with 0.2N.m torque.

Step 7 Install Spoke Reflectors

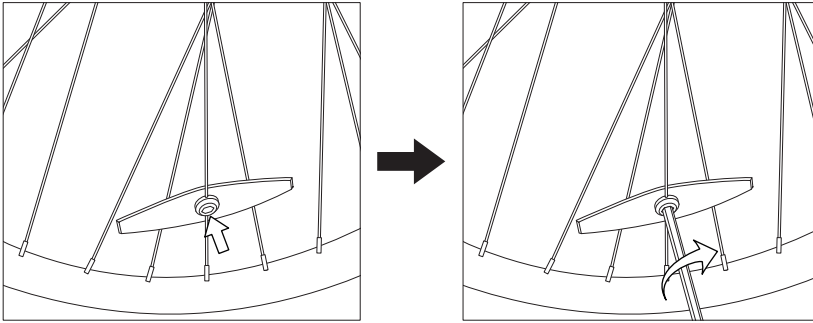

Step 8 Install The Seat

- A) Slide the seat post into the support frame.
- B) Adjust the seat to a suitable height and fix it by tightening and locking the quick-release clip.

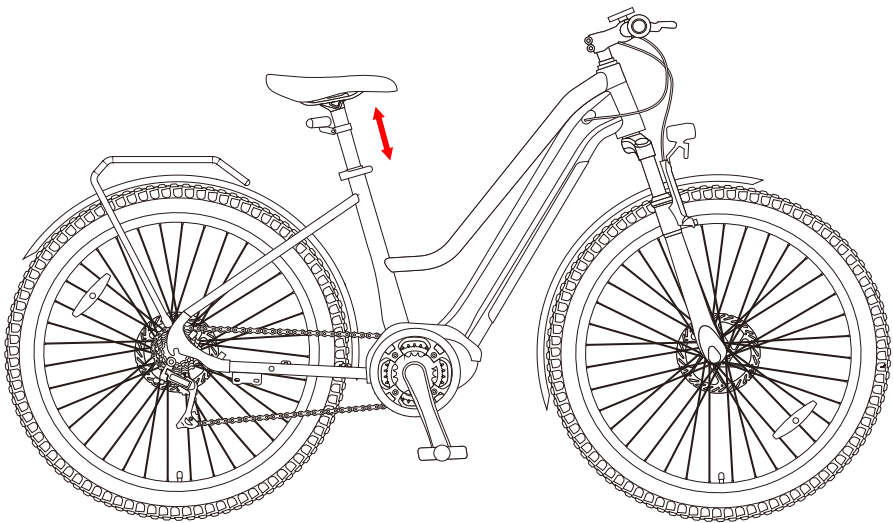

Step 9 Turn The Power on

- A) Lock the battery and turn the display on. Then it's ready to go!

6. LCD Display Guide

Warning

1. Please cut the power supply of the bike before you disconnect the display. Otherwise, it may cause permanent damage to the display.
2. Don't overtighten the screws when you install the display. Normally, the display can be mounted firmly on the handlebar with 0.2N.m torque. Overtightening it will cause permanent damage to the display.
3. Don't soak the display in the water or clean it with water spray. Use a soft and damp cloth to wipe it slightly. Do not clean it with detergent, alcohol, gasoline, acetone, or other corrosive/volatile solvents.
4. When you ride the bike on rainy days, please clog the USB port of the display to protect it from water and rain. Don't plug any devices in the USB port in the rain.
5. Please follow the local regulations about the disposal of the display.
6. Users will be responsible for the damage caused by improper or incorrect installation.

Diagram

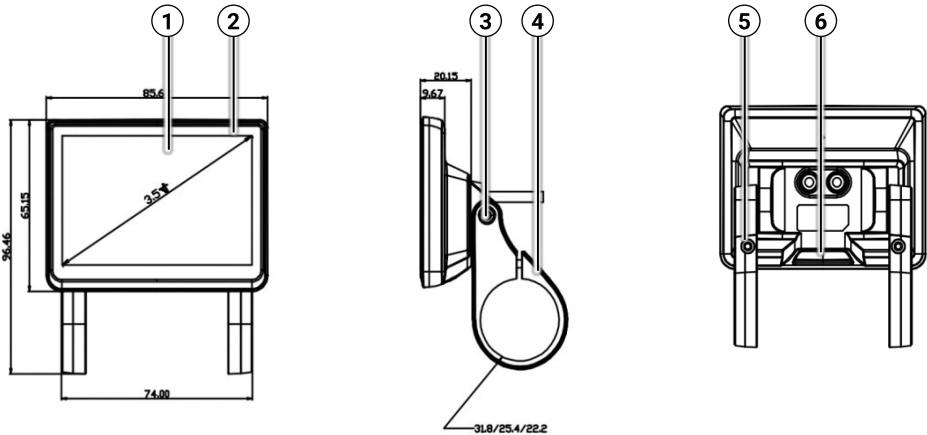

1	Screen	2	Shell
3	Screws for Adjusting Support Angle(M3*6)		
4	Supports	5	Screws for Fixing the Support(M3*12)
6	Rubber Clog of USB Port		

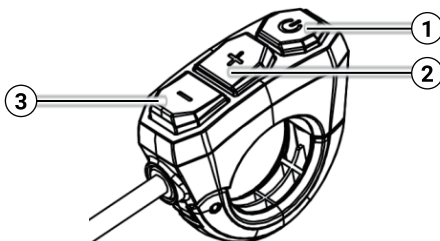

1	ON/OFF
2	UP
3	DOWN

Contents on the Display

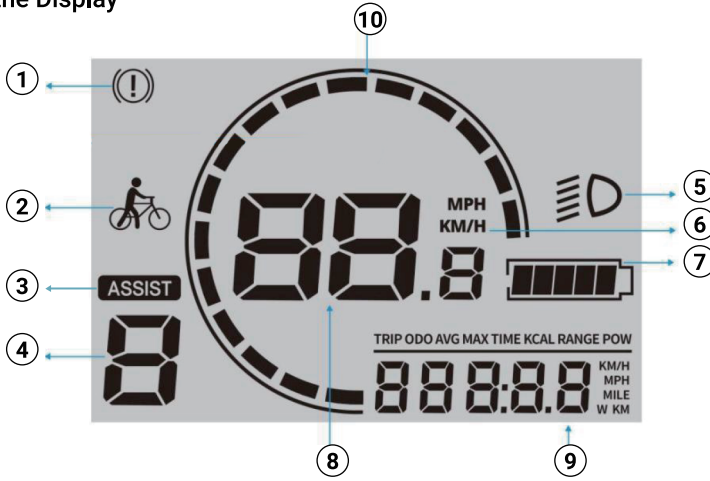

1	Malfunction Mark		Trip Distance
2	Push Mode		Odometer
3	Assist Mode		Single Average Speed
4	Assist Level	9	Single Maximum Speed
5	Light-on Mark		Trip Time
6	Speed Unit		Calorie
7	Battery Level Indicator		Power
8	Real-time Speed/Error Code	10	Speedometer

Note: trip data will be cleared when the display reboots.

Battery Level Indicator

[81% - 100%]

[21% - 40%]

[61% - 80%]

[6% - 20%]







[41% - 60%]

[0% - 5%]



Functions & Operations

Power on/off Long press to turn the display on/off.	Light on/off Long press to turn the bike light on/off.
Shifting Speed Level Short press or to shift among 5 speed levels, including 12km/h, 16km/h, 20km/h, 23km/h and 25km/h.	6km/h Push Mode Long press for 5s till the push mode mark turns up on the screen. Then the push mode is activated.

Activating More Functions



First, long press  to turn the LCD display on. Then long press  and  at the same time for 2-3 seconds to enter or exit the menu interface. In the menu interface, short press  to shift to the next menu and press  or  to set the menu items. To ensure users' safety, the menu interface can only work when the bike is stationary.

Adjusting LCD Backlight

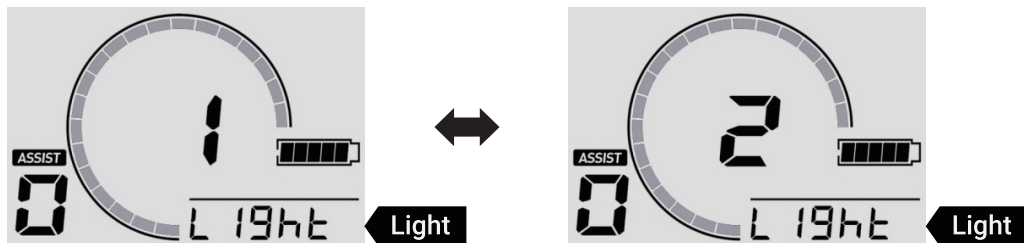
Enter the "Light" menu and adjust the LCD backlight illuminance by pressing  or . Level 1 is the darkest and level 5 is the brightest. Then press  to keep the change and exit the "Light" menu.



Setting Auto Power off

Enter the "OFF" menu and set the time within 0-10 minutes by pressing  or . 0 means the auto off function is turned off. Press  to keep the change and exit the "OFF" menu.

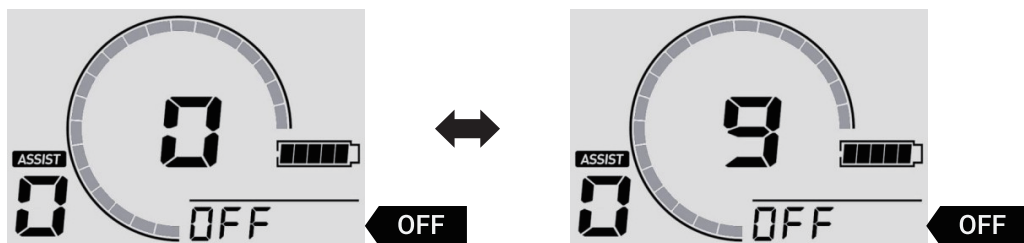

Changing Speed Unit

Enter the "Unit" menu and change the speed unit by pressing  or . Then press  to keep the change and exit the "Unit" menu.

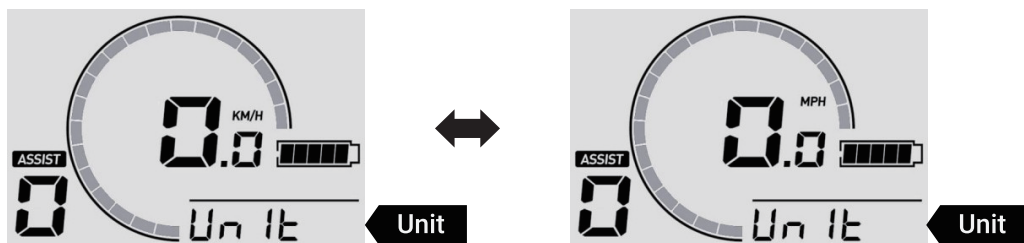

Error Tracking

When the malfunction mark shows up on the screen, the number at the center of the screen is the error code. Please check the following causes and solutions.



Error Codes	Causes	Solutions
21	Abnormal current or damaged MOS tube;	a.Replace the MOS tube; b.Replace the battery;
23	The motor is out of phase.	a.Replace the motor; b.Replace the motor adapter cable; c.Replace the controller;
24	Motor hall signal abnormality;	a.Replace the motor; b.Replace the motor adapter cable; c.Replace the controller;
25	Brake issue;	a.Adjust the brake lever to make sure it backs properly; b.Replace the brake lever; c.Replace the controller;
26	Undervoltage fault;	a.Charge the battery; b.Re-connect the battery and the controller; c.Replace the controller; d.Replace the display;
30	Communication error;	a.Re-connect the display and controller; b.Replace the display; c.Replace the controller;

Cleaning

Use a soft and wet cloth to wipe the mainframe clean. Dirt that is hard to remove can be scrubbed with a toothbrush and toothpaste, then cleaned with a soft and damp cloth. Do not wash your e-bike with alcohol, gasoline, acetone, or other corrosive/volatile solvents. These substances may damage the appearance and internal structure of the e-bike. Do not soak the bike or wash it with a pressure washer or hose.

Storage

A) Bicycle

1. Do not expose the e-bike to direct sunlight or rain for an extended period of time, and avoid storing it at a high temperature. It's better to store the bike in a dry and safe place at a temperature of 0°C-25°C.
2. Avoid corrosive gas, so as to avoid chemical corrosion and damage to the electrical parts and painted surfaces, which may lead to operational failure and accident.
3. Don't store it in an explosive or flammable environment or near flammable liquids.

B) Lithium-ion Battery

1. Charge the battery after each ride and avoid draining the battery completely. Because completely draining the battery may cause permanent damage to it. Never keep the lithium-ion battery discharged for a long time. If the voltage of the cell drops under allowed limit due to self-discharge, it will cause damage. For maximum durability, store the battery charged up to 50% of the maximum capacity.
2. Never charge the battery in an explosive or flammable environment or near flammable liquids. Do not charge the battery on a flammable substrate, such as paper, textiles, etc., when the battery is detached from the vehicle. Charge it at a safe place away from flammable items.
3. Never charge a battery which is already damaged or is leaking.
4. Don't charge the battery too long. Stop charging when it gets full.
5. Charge or discharge the battery at a temperature within 0~45°C.
6. It is better to store the battery indoors within 20°C~25°C temperature while it is not being used for a long time. (When used at 25°C, the battery range and performance is at its best. But using it at a temperature below 0°C can decrease its mileage and performance.)
7. Do not store the battery at a too high or too low temperature.
8. The humidity of the storage place should be 60±25%RH. As for the working place, the humidity should be 5~85%RH.
9. Do not puncture, hit or crash the battery.
10. Don't try to disassemble the old or damaged battery or throw it away. Please take it to the local professional battery recycling facility.

C) Other Parts

Head Sets	Remove, clean and lubricate the rims annually. Replace them if necessary.
Joints	Continuously check all nuts, bolts and quick-release devices for tightness.
Brakes	Lubricate the brake cables slightly with oil monthly. Check the adjustment and replace the brake parts (blocks, shoes, pads) in time if they are worn. The cables must be replaced if they are damaged/down.
Front Suspension Fork	Entrust it to experts.
Tires	Regularly check for damage, wear, cut and air leakage.
Wheel Hubs	Lubricate the hub bearings monthly. Check and adjust the cones, if necessary, to prevent the hubs from rubbing against the forks.
Pedals	Lubricate the bearings and check for tightness.
Cranks	Lubricate the bearings monthly (unless a maintenance-free center bracket is installed on the bike). Check whether all center bracket parts are correctly tightened.
Chain	Take it off and clean it every 6 months. The chain must be clean but not dry.
Rims	Frequently check whether the wheels are tight and secure. The rims should be protected from oil, wax, grease, adhesive, etc. Check whether the spokes are loosening or missing.
Sprockets	Clean regularly as necessary and grease lightly. Keep the front and rear derailleurs running smoothly by adjusting.
Saddle and Seat Post	Check whether the screws, nuts and quick-release devices are tight.
Kickstand	Clean and lightly grease it annually.

Attention: when lubricating, make sure the lubricant doesn't get on the brake discs and pads.

Otherwise, the brake system may fail to function.

8. Troubleshooting



Please check the following issues and solutions before sending the product to designated repair offices.

Problem	Possible Causes	Solutions
The display fails to work or the vehicle can't be turned on.	<ul style="list-style-type: none"> a. No power supply; b. The electric wire is not plugged in properly or tightly; c. The display is damaged; d. Controller burnout or water damage; 	<ul style="list-style-type: none"> a. Charge the battery; b. Reconnect the electric wire properly and tightly; c.& d. Contact the re-seller for help;
The front light fails to work.	<ul style="list-style-type: none"> a. The wire isn't plugged in properly; b. It is damaged; 	<ul style="list-style-type: none"> a. Plug the wire in properly; b. Contact the re-seller;
The battery fails to charge.	<ul style="list-style-type: none"> a. The charger isn't plugged in properly; b. It is out of the recommended temperature range; c. The battery is charged below rated voltage; d. It is damaged; 	<ul style="list-style-type: none"> a. Plug it in properly and charge it again; b. Charge it at a proper temperature; c. Charge it under rated voltage; d. Contact the re-seller;
Insufficient Riding Distance	<ul style="list-style-type: none"> a. Battery isn't fully charged; b. Low tire pressure; c. Frequent braking; d. Battery aging or battery capacity attenuation; e. Low ambient temperature; 	<ul style="list-style-type: none"> a. Fully charge the battery; b. Check the tire pressure before each use; c. Develop good riding habits; d.& e. It's normal;
The motor fails to work.	<ul style="list-style-type: none"> a. The brake lever doesn't back properly; b. The electric wire isn't plugged in properly; c. The sensor or controller is inefficient; 	<ul style="list-style-type: none"> a. Adjust the brake lever; b. Plug the electric wire in properly; c. Contact the re-seller for help;

Attention: if any other failures occur and you can not find any solution from the chart above, please contact the re-seller to solve it. Any other maintenance and repair that need to be done by using professional tools and techniques, should be performed by a qualified bicycle mechanic designated by manufacturer or the maintenance center.