

PRODUCT FUNCTION DIAGRAM

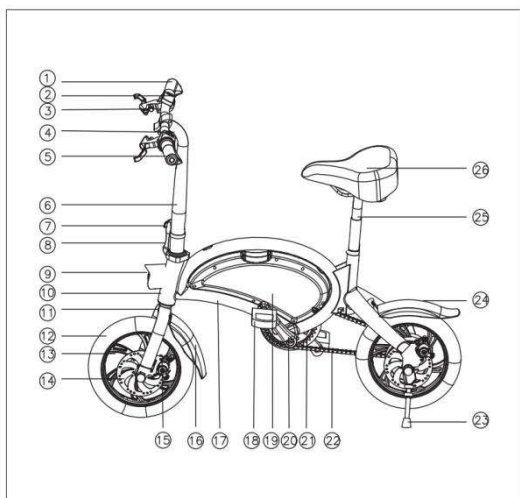

1. Gear shift
2. Dash board
3. Brake handle
4. Handle bar
5. Power button
6. Standpipe
7. Vertical folding clasp
8. Safety buckle
9. Front light
10. Head tube
11. The front fork
12. Tyre
13. Wheel hub
14. Brake disc
15. Disc brake
16. Front fender
17. Frame
18. Pedal
19. Battery box
20. Crank
21. Chain wheel
22. Chain
23. Kickstand
24. Back fender
25. Seat tube
26. Seat

Note: Some details of your bike may be little different from the above picture due to our product upgrading, which will not affect the usage.

LIST OF ACCESSORIES

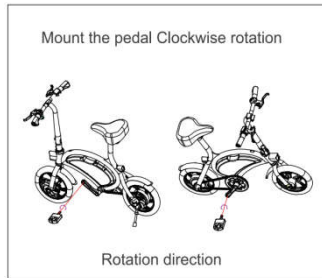
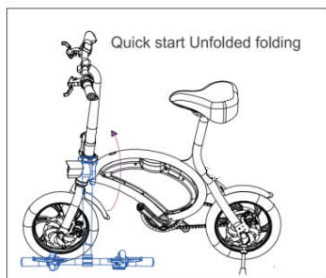
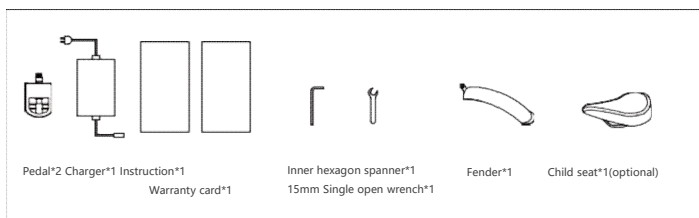

FUNCTION

1. **Installation:** After unpacking, loosen the handle bar & quick release, adjust the horizontal handle to the right direction, lock the horizontal handle, and gently hold the brake lever several times, adjust the brake lines to the best condition.
2. **On/off:** Press the switch button on left handle bar to turn on the E-bike, the dash board will light up; Press the switch button again to turn off the E-bike.
3. **Charging:** Connect the charger to the power plug and then to the E-bike. When the charger indicator turns green from red, it shows full power.
4. **Battery status:** After booting, the dash board lights up and the electricity shows up, it has four grids, Corresponding to high power, medium power and low power respectively
5. **Braking:** Use disc brakes, **you can not speed up before fully loosed.**
6. **Headlight:** the headlight is in manual control mode, the control button under the meter, press it 3-5 seconds to turn on/off the light.
7. **Zero speed booting:** When the E-bike on standby mode, you can accelerate with speeding bar.
8. **Speed up:** Please accelerate the E-bike slowly, do not twist the throttle bar too hard, in case of broken.
9. **Cruise control:** While riding, keep the handle stationary and ride at a constant speed for 8 seconds. If you release the handle, it can move at a constant speed. If you brake again or accelerate again, will cancel the cruise function.
10. **Electric mode and Assisting mode:** the default of the E-bike is assisting mode, only one gear. While it is assisting mode, also can use the electric mode.

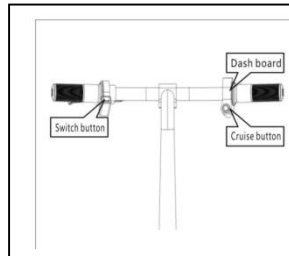
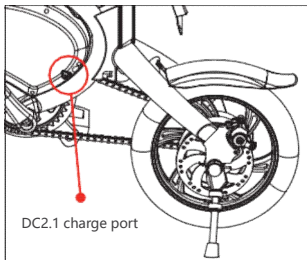

PARAMETERS

Size	Material	Metal
	Folding size	1170*200*720mm
	Released size	1170*500*990mm
	Pedal height	120mm
	Hub size	14inch
	Package size	1195*220*610mm
	Color	Black
	Material	Metal
Performance	Weight	19kg
	Max load	120kg
	Riding speed	20km/h
	Max speed	25km/h
	Mileage(pure electric)	40±3km
	Assistant-Mileage	50km
	Uphill	15 degree
	Temperature	-10~45°C
	Waterproof	IP54
Standards	Battery	10Ah
	Rated power	250W
	Rated voltage	36V
	Charging voltage	DC42V
	Input voltage	AC100~220V
	BMS	Yes
	Charging time	6-8H
Features	App	No
	Personal sticker	Optional
	Lights	Yes/ Head light+ Frog rear light
	Cruise	Yes
	Brake mode	Front and rear disc brakes

Remark: Many factors will affect the max speed,such as power,load,tyre pressure,road conditions,chain,lubrication degree etc. Mileage has been measured on basis of temperature 25°C,load of 60KG,speed of 15-20KM/H,smooth and hard road,and from full battery to dead battery. It also is subjected to other factors,such as driving habits,temperature,load,tyre presure,road conditions etc.*

CAUTION

Charge between 0 degree- 45 degree, rife between -20 degree to 60 degree, keep the battery dry. Don't put it in acid and alkalinity fluid. No rain, fire and heat. Don't put the battery positive an negative wrong. Don't damage disassemble the battery or use the wrong adapter. Don't charge it over 6 hours and don't charge it over 2A.

When not using for a long time, please put the battery in dry and cool place and charge it for 2 hours every 2 months. Follow the instruction or the user will be responsible for the consequence.

When charging, Please be careful of the battery type and voltage, place the battery in open air and don't put it under bright sun shine and closed space.

When charging, please place the battery first, then connect the electricity; after charging, cut the electricity then cut the battery plug. When the green light lights up, turn off the power, don't connect the battery when not charging.

When charging, if the indicating light goes wrong or some strange smell shows up or the charger is over hot, please stop charging immediately, them check and repair or replace the charger. When using or storing the charging. In case of something wrong were dropped into the charger, especially the water or other fluids, please don't take the charger when possible. Otherwise, be careful and put it in the cool box. No disassembling the charger yourself.

Please check the brake before riding.

Please brake the rear wheel first.

Be careful of the tightness of brake, use the hexagon wrench when it's loose.

Rainy and snowy days need longer braking distance.

Suitable age :16-45 years old.

Riding

Read the instruction first to know the product performance first.

Don't lend it to someone who is not familiar with it.

Wear a helmet when riding. Obey the traffic rules and don't ride it in the cars road. Don't riding it in the crowded road.

When go downhill or slippery road, the speed should be under 15km/h.

Inspect the Tyre before riding, Tyre pressure should be 35-45PSI.

Don't over impact the motor, keep the axle smooth.

Don't over load.(Max load is 120kg)

Please be careful of the adding distance when it under the rainy day and snow day.

Single-handed ride is prohibited.

Maintenance

The E-bike front and back wheel should be at the center of the frame.

Put the E-bike up after riding at cool and dry place.

Check the Motor and Brake often, **don't inject the oil onto the brake.**

Check the E-bike and screws and places that need fixing, fix it often.

Suggested torsion: Bar screws 60-80 kgf.cm, bar stand screws 175-200kgf.cm, wheel screws 320-450kgf.cm.

Check the Tyre is pierced and leaks air, please contact professional technician for repairing and replacing.

Responsibility announcement

All the product model, type and related information copy right and explain right are reserved.

This instruction is suitable for denoted models.

Any changing or replace part of the E-bike will not be informed again.

No copy, modification, propaganda or publication before getting the permission form F-wheel.

Read the instructions and follow the instructions or the user will be responsible for the damage.

For more information please visit : www.dyu.vip .



DYU SMART ELECTRIC BIKE-D3F (10AH)

