



PURETILT[®] PT3000-18 MANUAL TILT WHEELCHAIR OWNER'S MANUAL

SAVE THIS MANUAL FOR FUTURE USE.

CONTENTS

1	INTRODUCTION.....	3
	INTENDED USE.....	3
	STATEMENTS OF SIGNIFICANCE.....	3
2	IMPORTANT SAFETY PRECAUTIONS.....	4
	WARNINGS.....	4
3	FEATURES.....	6
	PURETILT® LABELS.....	7
4	GETTING STARTED.....	8
	OPERATING THE WHEEL LOCKS.....	8
	INSTALLING THE FRONT CASTERS.....	8
	INSTALLING AND OPERATING THE ANTI-TIPPERS.....	9
	INSTALLING THE HEADREST.....	9
	UNFOLDING AND FOLDING THE WHEELCHAIR.....	10
	UNFOLDING THE WHEELCHAIR.....	10
	FOLDING THE WHEELCHAIR.....	10
5	HANDLING TIPS.....	11
	BALANCE.....	11
	TRANSFER.....	11
	REACHING / BENDING.....	12
	REACHING / BENDING FORWARD OR SIDEWARD.....	12
	REACHING / BENDING BACKWARD.....	12
	RAMPS AND INCLINES.....	13
	ASCENT.....	13
	DESCENT.....	13
	CURBS.....	13
	CURBS – WITH ATTENDANT.....	14
	GOING UP (METHOD 1).....	14
	GOING UP (METHOD 2).....	14
	GOING DOWN.....	14
	STAIRS AND ESCALATORS.....	14
	WEIGHT TRAINING.....	14
6	OPERATION.....	15
	ROTATING THE ARMS.....	15
	OPERATING SEAT TILT.....	16
	OPERATING SEAT TILT: BY USER.....	16
	OPERATING SEAT TILT: BY CAREGIVER.....	16
7	ADJUSTMENTS.....	17
	REAR WHEELS AND CASTERS.....	17
	BACK.....	17
	ADJUST BACK HEIGHT.....	17
	REMOVE THE BACK.....	17
	HEADREST.....	18
	ADJUST HEADREST HEIGHT.....	18
	LEGREST / FOOTPLATE.....	18
	ADJUST LEGREST / FOOTPLATE LENGTH.....	18
	ADJUST LEGREST ANGLE.....	19
	RETRACT LEGREST FOR STORAGE OR FOOT PROPULSION.....	19
	SEAT.....	20
	SEAT TILT FORCE.....	20
	ADJUST SEAT TILT FORCE.....	21
	WHEEL LOCKS.....	22
	ADJUST WHEEL LOCKS.....	22
8	TRANSPORTING THE PURETILT.....	23
	PREPARATION FOR TRANSPORT / FOLDING THE WHEELCHAIR.....	23
	FOLD BACK FORWARD.....	23
	TRANSPORTING THE WHEELCHAIR.....	23
9	MAINTENANCE.....	24
	SERVICE MANUAL.....	24
	DO-IT-YOURSELF MAINTENANCE.....	24
	LIST OF TOOLS.....	25
	GENERAL CARE.....	25
	CHECK AT LEAST EVERY WEEK.....	25
	CHECK TIRE WEAR.....	25
	CHECK HANDRIMS.....	25
	CHECK WHEEL LOCK ENGAGEMENT.....	25
	CHECK ANTI-TIPPERS.....	25
	WIPE OFF FRAME.....	25
	CHECK AT LEAST EVERY MONTH.....	25
	CHECK HANDGRIPS.....	25
	CHECK UPHOLSTERY.....	26
	CLEAN UPHOLSTERY AND PLASTIC COMPONENTS.....	26
	CHECK REAR WHEEL ADJUSTMENT.....	26
	CHECK ARMS.....	26
	CHECK ARM AND BACK LOCKING LATCHES.....	26
	CHECK LEGREST AND FOOTPLATE.....	26
	CHECK AT LEAST EVERY THREE MONTHS.....	26
	CLEAN FRAME.....	26
	CHECK CASTER AXLE AND STEM ROTATION.....	26
	CHECK AT LEAST EVERY SIX MONTHS.....	26
	MAINTENANCE CHECK.....	26
	CHECK CASTER AND REAR WHEEL BEARINGS.....	26
10	TROUBLESHOOTING.....	27
11	SPECIFICATIONS.....	28
12	DISPOSAL.....	29
13	LIMITED WARRANTY.....	30
14	INDEX.....	31



READ THIS MANUAL BEFORE OPERATING YOUR WHEELCHAIR

1 INTRODUCTION

Thank you for choosing an Everest & Jennings product. Important safety, operating, and maintenance instructions that warrant your attention are included in this user manual. Read the entire manual carefully before operating your new wheelchair, and refer to it as often as necessary to help maintain good performance standards. If you have further questions, call Graham-Field Customer Service at 1.770.368.4700.

Consult your healthcare professional and GF Health Products, Inc., ("GF") authorized distributor for assistance in developing and learning safe and effective techniques for performing your daily activities according to your individual physical abilities and needs, and to make certain that your wheelchair is properly prescribed and adjusted for your use.

The safety precautions in this manual are general warnings intended to be used only as basic guidelines. You may find it necessary to develop your own methods for safely solving frequently encountered challenges. Again, consult your professional medical advisors for their recommendations about safety methods, and never hesitate to ask for their assistance.

Your wheelchair should receive frequent, regularly scheduled maintenance, including an inspection of the mechanical parts, to ensure proper operation. Some suggested inspection procedures, troubleshooting procedures, and adjustment procedures are included in this manual. When it comes to service and repair, remember that your GF authorized distributor knows your wheelchair best.

The person performing adjustments on the PureTilt® has the responsibility of making certain that the user can safely operate the wheelchair with the adjustments selected. This person must evaluate the user's ability, weight, physical condition, the environment in which the wheelchair will be used, and the terrain over which the wheelchair will travel. We recommend the use of anti-tippers at all times.

INTENDED USE

The PureTilt's intended use is to provide mobility to those who are unable to ambulate safely or are restricted to a sitting position. The PureTilt is a manual indoor / outdoor wheelchair suitable for frequent users who require a portable wheelchair.

STATEMENTS OF SIGNIFICANCE

Please note the following special statements, used throughout this manual, and their significance:

- ⚠ WARNING:** Indicates a potential hazard situation or unsafe practice that, if not avoided, could result in death or serious personal injury.
- ⚠ CAUTION:** Indicates a potential hazard situation or unsafe practice that, if not avoided, could result in minor or moderate personal injury.
- ▲ NOTICE:** Indicates a potential hazard situation or unsafe practice that, if not avoided, could result in product or property damage.

Info: Provides application recommendations or other useful information to ensure that you get the most from your product.

2 IMPORTANT SAFETY PRECAUTIONS

IMPORTANT SAFETY PRECAUTIONS: ALWAYS FOLLOW THESE SAFETY PRECAUTIONS WHEN USING YOUR WHEELCHAIR. FAILURE TO DO SO COULD RESULT IN PERSONAL INJURY TO YOU OR OTHERS OR DAMAGE TO YOUR WHEELCHAIR.

Safety requires the constant attention of the wheelchair user and the attendant. It is extremely important to learn and always use safe methods of performing basic daily activities. Always consult your healthcare professional to determine those methods most suitable for your individual abilities.

Protect yourself and your wheelchair by having your PureTilt serviced regularly. Whenever any part of your PureTilt is not functioning properly, contact your GF authorized distributor immediately, as a hazardous situation could result, causing personal injury or damage to your wheelchair. **ONLY EXCELLENT CONDITION IS ACCEPTABLE WHERE SAFETY IS CONCERNED.** Periodic inspection, adjustment, and replacement of worn parts will provide many years of superb performance.

WARNINGS

- ⚠ WARNING: PureTilt maximum weight capacity is 300 lb (136.1 kg), EVENLY DISTRIBUTED.**
- ⚠ WARNING: We recommend the use of anti-tippers at all times to prevent the PureTilt from tipping backward and causing injury. Anti-tippers must be installed in the downward position.**
- ⚠ WARNING: Keep hands free of moving parts.**
- ⚠ WARNING: Do not operate this wheelchair on streets or roadways.**
- ⚠ WARNING: Do not operate this wheelchair on hilly or rough terrain, sand, mud, snow, wet or icy surfaces, or surfaces with impaired traction. Ensure that pathway is clear of all obstacles.**
- ⚠ WARNING: Do not operate this wheelchair in shower, pool, or water.**
- ⚠ WARNING: Do not turn wheelchair while going downhill, as wheelchair could tip over.**
- ⚠ WARNING: Do not attempt inclines without anti-tippers installed in the downward position. Do not attempt any incline or decline greater than six degrees (10% grade, or one foot of rise or fall per ten feet of ramp length).**
- ⚠ WARNING: This wheelchair does not offer seating or occupant restraint equivalent to the seat provided in a motor vehicle! To increase your safety while traveling in a motor vehicle, always transfer to the vehicle seat and use the restraint provided by the vehicle manufacturer.**
- ⚠ WARNING: Do not tie down or attach anything to the wheels. This could cause tipping and possibly result in injury or damage to the wheelchair.**
- ⚠ WARNING: The footplate's lowest point should clear the ground by at least 2 1/2 in. (6.4 cm), to permit proper clearance of potential obstruction.**
- ⚠ WARNING: Doing a "wheelie" (tilting the wheelchair backward until it reaches its balance point) is dangerous and could result in personal injury to the user.**

- ⚠ WARNING: Do not stand or step on the footplate while transferring to or from your wheelchair. This could cause the wheelchair to tip or may cause personal injury or damage to your wheelchair.**
- ⚠ WARNING: Do not place your hand between seat rail and side panel.**
- ⚠ WARNING: Always engage wheel locks before transferring, using a wheelchair lift, or using an elevator.**
- ⚠ WARNING: Ensure that wheelchair is on a stable, level surface and engage wheel locks before and during transfer.**
- ⚠ WARNING: Operate only with anti-tippers in place when leaning or tipping. When in use, anti-tippers must be installed in the downward position.**
- ⚠ WARNING: Do not lean over the top of the wheelchair back. This could cause the wheelchair to tip over.**
- ⚠ WARNING: To reduce the risk of tipping before leaning or reaching forward, sit back in the seat and rotate casters fully toward front of wheelchair.**
- ⚠ WARNING: Unauthorized modification or the use of non-Everest & Jennings replacement parts could change the structure of the wheelchair, void the warranty, and create a hazardous condition resulting in serious personal injury.**
- ⚠ WARNING: Do not lean on this wheelchair or use it as a walker — these are practices which could result in loss of balance and personal injury.**
- ⚠ WARNING: Do not use your wheelchair on escalators.**
- ⚠ WARNING: Wheel locks are not brakes. Do not use the wheel locks to slow down your wheelchair, or while the wheelchair is moving. Wheel locks are only intended to keep the wheelchair in place when it is at a complete stop.**
- ⚠ WARNING: GF Health Products, Inc. specifically disclaims responsibility for any personal injury or property damage which may occur during any use which does not comply with federal, state, or local laws or ordinances.**

3 FEATURES

Familiarize yourself with main components, identified in PureTilt illustration below.



PureTilt™ Manual Tilt Wheelchair

The Everest & Jennings® PureTilt™ wheelchair comprises two main assemblies: a lower frame assembly and a tilting seat assembly. The lower frame comprises two rear wheels, two front casters, two anti-tippers, one pair of wheel locks, and two arm subassemblies. The seat assembly comprises four sub-assemblies: a tilting seat, a legrest, a back, and a headrest. The following features are standard:

- Tilting seat with adjustment capability from 5° to 40° depending on body weight and tilt force adjustment position
- User / caregiver-operated seat-tilt adjustment mechanism assisted by a gas spring piston
- Hinged, non-detachable arms that swing up and back to facilitate transfer
- Built-in housing for compatible transfer board
- Two 22 in. (55.9 cm) diameter rear wheels with aluminum handrims for self-propulsion
- Two 6 in. (15.2 cm) diameter front casters that swivel for easy maneuvering
- Adjustable seat-to-floor height to either 19.75 in. (50.1 cm) or 21.75 in. (55.2 cm)
- Angle-adjustable legrest assembly with the following features:
 - Footplate that swings upward and locks in place to facilitate storage
 - Telescoping adjustable length
 - User-operated mechanism to adjust legrest angle, assisted by a gas spring piston
- Height-adjustable back that folds forward to facilitate storage and transport
- Height-adjustable headrest

PURETILT LABELS

You will find the following labels on the PureTilt wheelchair; descriptions are listed below and their locations are shown in the illustrations at the bottom of the page. **Do not remove labels.**

A The chair identification label, shown at right, identifies the chair serial number and model, essential information when ordering replacement parts or claiming parts under warranty. The identification label location is shown below. Have this information ready when calling our Customer Service or Technical Support staff at 1.770.368.4700; it will allow us to better assist you and quickly answer your questions and concerns.

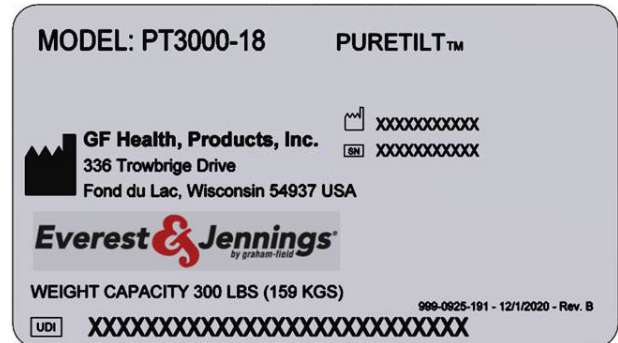

A

B ⚠ **WARNING: Do not Operate Before Reading And Understanding Owner's Manual**

C ⚠ **WARNING: Do Not Occupy While In Motor Vehicle**

D ⚠ **WARNING: Do Not Occupy Without Anti-tippers Installed**

E ⚠ **WARNING: Not A Step. Do Not Stand. Do Not Lift From Here**

F ⚠ **WARNING: Do Not Occupy Without Pin Inserted All The Way Through**

G Max weight capacity - 300 lb (136.1 kg) **EVENLY DISTRIBUTED**

H Push to Release

I Footrest (Raise / Lower)

J Backrest (Tilt)

K Tire Size: 22 in. x 1 3/8 in. (55.9 cm x 3.5 cm)

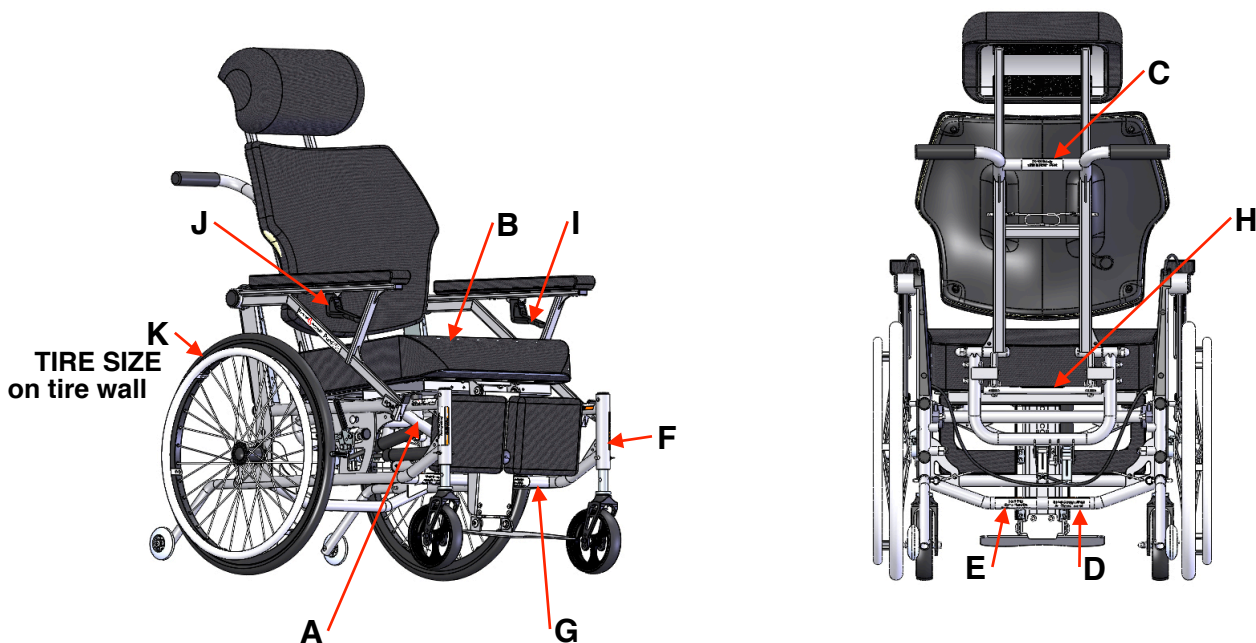

4 GETTING STARTED

OPERATING THE WHEEL LOCKS

⚠ WARNING: Always engage wheel locks before transferring, using a wheelchair lift, or using an elevator.



Unlocked



Locked

Two wheel locks are located on the PureTilt; one on each of the rear wheels.

1. To lock, push the Wheel Lock Handle toward the front of the wheelchair until the wheel is locked.
2. To unlock, pull the Wheel Lock Handle toward the back of the wheelchair until the wheel is unlocked.

INSTALLING THE FRONT CASTERS

Info: Seat height is factory-set in the highest position. Changing seat height (wheel position) requires wheel lock adjustment.

1. Tip wheelchair all the way backward to rest on push handles.
2. Remove caster stem retaining pin from caster mounting tube at front of PureTilt frame — pull the wire lock off the end of the pin, pivot wire lock out of the way, and pull the pin from the tube.
3. Insert a caster stem into the caster mounting tube.
4. Align the upper caster stem through-hole, to match factory-set rear-wheel high height, with the two mounting tube holes.

Info: Contact your GF authorized distributor when your rear wheels or casters need adjustment, or if you wish to change seat height to low position.

5. Insert the pin all the way through the mounting tube until the pin's shoulder rests against the tube.
6. Lock the pin in place with the wire lock by pivoting the wire lock around the back of the tube and clipping it over the end of the pin, as shown in Caster Stem Retaining Pin illustration at right.
7. Repeat steps 1-6 for second caster.

⚠ WARNING: Ensure both casters are securely attached *at the same height*.



Caster Stem Retaining Pin with Wire Lock



Caster Stem Shown Locked in Place

INSTALLING AND OPERATING THE ANTI-TIPPERS



Upward



Downward

Anti-tippers Rotated to Upward and Downward Positions

1. Select the appropriate set of ports for the current height setting of the wheelchair (upper ports for hemi height, lower ports for standard height, as circled at above left).
2. Insert one anti-tipper rod in each appropriate port.
3. Rotate the inserted rod so the anti-tipper wheel is pointing downward, as shown at above right.
4. Align the anti-tipper rod through-hole with the two holes in the selected port.
5. Insert the adjacent quick-disconnect pins all the way through the mounting ports until the tension balls at the ends of the pins completely clear the holes. **Note: Ensure the lanyard is not caught in the moving parts of the wheelchair.**

⚠ WARNING: When in use, anti-tippers must be positioned with wheels downward.

Info: To travel over curbs, the anti-tippers may be temporarily positioned with wheels upward.

INSTALLING THE HEADREST

Info: To install headrest, orient the convex surface of the headrest padding toward the front of the wheelchair as shown at right.

1. Insert the two vertical posts into the mounting tubes at the top of the back frame as shown at right.
2. While holding the headrest at the desired height, align the hole in each post with the matching hole in each mounting tube.
3. Insert the quick-disconnect pins, circled in red at right, all the way through the posts and headrest mounting holes until the tension balls at the ends of the pins completely clear the tubes.



Installing the Headrest

UNFOLDING AND FOLDING THE WHEELCHAIR

UNFOLDING the Wheelchair

Info: There is a back lock on each side, one near each pivot point.

1. Engage wheel locks on both sides.
2. Rotate the back frame rearward. The back will lock into place in the upright position.

⚠ WARNING: Ensure seat, back and arms are locked in place before occupying or operating wheelchair.



FOLDING the Wheelchair



1. Engage wheel locks on both sides.
2. Push down on release bar and rotate back frame forward, as shown above.
3. Remove the seat cushion to further lower the back.

5 HANDLING TIPS

The Everest & Jennings PureTilt has been designed and engineered to perform as a stable and well balanced unit when used for its intended purpose. However, it is possible to tip the PureTilt over if it is used improperly or if you move beyond the center of gravity. You may want to consider the use of a positioning belt, available from your distributor or www.grahamfield.com, to maintain proper weight distribution. We urge you to learn the characteristics of your wheelchair. It is most important to learn safe methods to perform the daily activities basic to your lifestyle. Consult your medical professionals for assistance in developing the skills and proper techniques to perform all activities safely.

BALANCE

Proper balance is the key to maintaining the stability of your wheelchair. Reaching, bending, and transferring to or from a wheelchair will change your weight distribution and center of gravity. When performing such activities, do so as instructed in the following paragraphs to avoid tipping the wheelchair.

TRANSFER

- ⚠ **WARNING:** Always ensure the wheelchair is on a stable, level surface before transfer.
- ⚠ **WARNING:** Always engage wheel locks before transfer.
- ⚠ **WARNING:** Do not step on the footplate; this could cause the wheelchair to tip. Fold it up and secure it under leg pads.
- ⚠ **WARNING:** There is a critical moment when there is little or no seat platform beneath you. Take every precaution to reduce this unsupported distance before you attempt transfer.

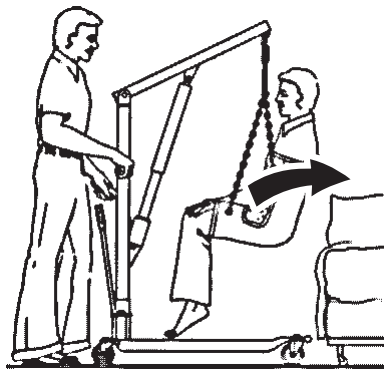

Patient Lift Transfer

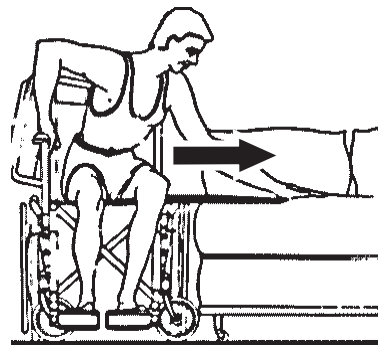

Transfer Board Transfer

Transferring into or out of a wheelchair is a very difficult maneuver; always exercise extreme care even when transferring with the aid of an attendant, a patient lift (shown at above left), or a transfer board (shown at above right). Consult your medical professionals for assistance in developing your individual transfer technique. Engage both wheel locks and ensure the wheelchair is stabilized and will not move or slide during the transfer. Take extra precautions to prevent tipping. Use good body mechanics to prevent personal injury.

REACHING / BENDING

⚠ WARNING: Always turn the casters frontward to provide stability while reaching. If in doubt, ask for assistance or use a device that will extend your reach without requiring you to shift your weight.

Although it is not recommended, you may find it occasionally necessary to lean or reach from your wheelchair. Consult with your healthcare professional for assistance in developing your personal safe reaching or moving techniques suited to your ability and restrictions.

Reaching / Bending Forward or sideward

⚠ WARNING: Do not attempt to reach objects if you are required to move forward in the seat. Do not attempt to retrieve objects from the floor if you must reach down between your knees. Do not shift your weight in the direction that you are reaching and/or bending; this could cause the wheelchair to tip.

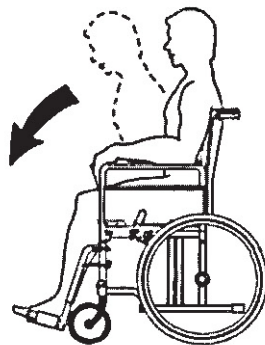

Reach Forward



Reach Sideward

1. Maneuver the wheelchair as close as possible to the object you wish to reach.
2. Rotate both casters fully forward: Go forward, and then back the wheelchair toward the object to swing the casters fully forward.
3. Engage both wheel locks.
4. Ensure the casters are rotated fully forward before reaching. If not, repeat step 2.

Reaching / Bending Backward

⚠ WARNING: Do not engage the wheel locks while reaching or bending backward. Should your weight suddenly shift accidentally, it is better to roll in that direction than to tip over.

⚠ WARNING: Do not lean over the back upholstery; this could cause the wheelchair to tip.

1. Maneuver the wheelchair as close as possible to the object; the rear wheels will limit how close you can get.
2. Rotate both casters fully forward: Go forward, and then back the wheelchair toward the object to swing the casters fully forward.
3. Reach only as far as your arm will extend without changing your sitting position. If in doubt, reposition the wheelchair or ask for assistance.

RAMPS AND INCLINES

- ⚠ **WARNING: DO NOT** attempt curbs or inclines while in the tilted position. The wheelchair must be in full upright position.
- ⚠ **WARNING:** During descent, the footplate's lowest point should be no closer to the ground than 2 1/2 in. (6.4 cm) to permit proper clearance.
- ⚠ **WARNING:** Do not attempt inclines without anti-tippers installed. Do not attempt any incline or decline of more than 6 degrees (10% grade, or one foot of rise or fall per ten feet of ramp length).
- ⚠ **WARNING:** Do not use wheel locks to slow your descent. Attempting to use wheel locks is likely to result in accidental locking that could cause the wheelchair to stop abruptly, suddenly pitch forward, or tip sideways.
- ⚠ **WARNING:** Avoid changing direction while descending a ramp or incline, as this could cause instability.

Most people are capable of negotiating short inclines without assistance, depending upon upper body strength, endurance, and the degree of incline. Know your own strength and endurance capabilities and limitations before attempting to negotiate an incline or decline. Practice with an attendant or healthcare professional first before attempting any inclines, declines or ramps. Always inspect the ramp for hazards such as holes, slippery or uneven surfaces, etc. before starting up or down. If you can not see the entire ramp, ask someone to inspect it for you.

Ascent

Lean the upper part of your body slightly forward, as shown above, as you ascend the incline. If it becomes necessary to stop on the incline, avoid any abrupt or sudden forward movement as you resume climbing; this could cause tipping.

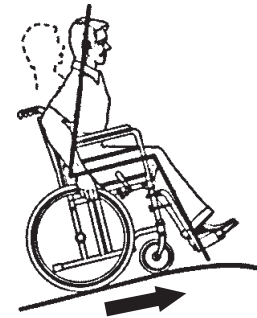

Descent

Always face forward when going down a ramp, but do not lean forward; this could cause tipping. Lean slightly backward to increase stability. It is critical to keep the wheelchair under control at all times. Descent should be made slowly and safely by grasping the handrims; however, use care, as friction heat will be generated. We recommend the use of gloves to reduce the effects of friction heat, but going slower is a better alternative.

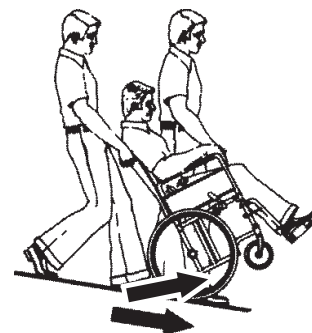

CURBS

Curbs should only be negotiated with the assistance of an attendant. When you encounter curbs, find a way around, or use the ramps now available in most locations. If there is no ramp available, avoid the curb by using the disabled-designated elevators now required in most locations.

Curbs – with Attendant



Going up (Method 1)

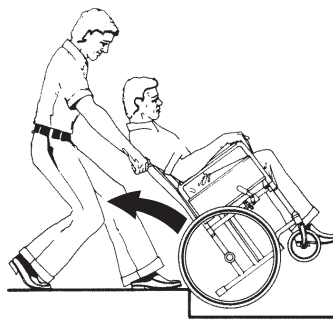

Going Up (Method 2)

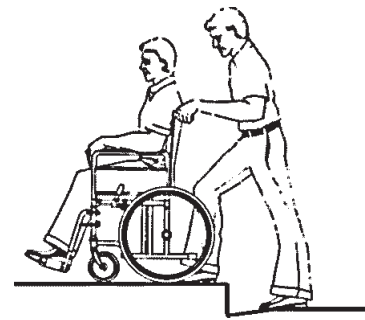

Going Down

⚠ WARNING: When approaching a curb, ensure the hand grips are securely fastened and do not turn or slip off.

Curbs should only be negotiated with the assistance of an attendant. The following are **suggestions only** for curb negotiation. It is important for you to develop your own safe technique that is best suited for your abilities with the aid of your healthcare professionals.

Going Up (Method 1)

When approaching a curb, ensure the hand grips are securely fastened and do not turn or slip off. Tilt the wheelchair backward to its balance point and move forward until the front casters pass over the top of the curb. Lower the front casters slowly onto the curb, lift the wheelchair by the push handles, and push forward until the rear wheels roll up and over the curb. Ensure the wheelchair has completely cleared the curb and can not roll backwards.

Going Up (Method 2)

Ensure the hand grips are securely fastened and do not turn or slip off. Turn the wheelchair around and back up until the rear wheels are against the curb. Tilt the wheelchair back to its balance point and lift up by the push handles while pulling the wheelchair up and over the curb. **DO NOT** let the front casters down until the wheelchair is back far enough to clear the curb.

Going Down

Ensure the hand grips are securely fastened and do not turn or slip off. While standing behind the wheelchair, turn the wheelchair around and carefully back down the step. Hold the handgrips tightly and pull the wheelchair to where the rear wheels reach the curb edge, then slowly roll the rear wheels down onto the lower level. After the wheels are safely on the lower level, tilt the wheelchair back to its balance position and turn it to face forward. Lower the front casters carefully by placing one foot on the tipping lever and gradually decreasing the force of exertion.

STAIRS AND ESCALATORS

⚠ WARNING: Never attempt to negotiate stairs or escalators in your PureTilt.

Stairs and escalators are dangerous obstacles. If you encounter steps and there is no ramp available, avoid the steps by utilizing the disabled-designated elevators now required in most locations.

WEIGHT TRAINING

⚠ WARNING: This wheelchair is not designed or tested as a seat for weight training.

6 OPERATION

ROTATING THE ARMS



The arms swing above the horizontal (upward and toward the back) to facilitate transfer, as shown at above left.

1. To unlock the arm, push the arm release handle, circled in red at above right.
2. Swing arm upward and toward the back to desired position.

Info: the arm's built-in friction prevents it from swinging free; this friction makes the arm feel slightly difficult to swing.

3. To rotate the arm back down and lock it into place, swing the arm down toward the front of the wheelchair and press firmly until the arm clicks into locked position. Lift up on arm to verify it is locked.

⚠ WARNING: Ensure arms are locked into place before operating wheelchair.

OPERATING SEAT TILT



PureTilt Shown Tilted

Operating Seat Tilt: by User

⚠ WARNING: Always engage the wheel locks, lock the arms into place, and lower the footplate before tilting the seat. Ensure anti-tippers are installed and in proper location.

⚠ WARNING: Avoid accidental actuation of seat tilt and footrest levers.

1. Sit on the wheelchair with your feet resting on the footplate. Ensure wheel locks are engaged and arms are locked in place.
2. Locate the tilt handle, circled in red above, on the right arm.
3. To tilt the seat backward, squeeze and hold the tilt handle, push against the arm, and lean backward.
4. Release the tilt handle at desired degree of tilt to lock the seat into position.
5. To bring the seat back to upright position, grasp the tilt handle, lean forward, and pull your body weight forward.
6. Release tilt handle at upright position to lock the seat into position.

Operating Seat Tilt: by Caregiver

⚠ WARNING: Always engage the wheel locks, lock the arms into place, and lower the footplate before tilting the seat. Ensure anti-tippers are installed and in proper location.

1. Have the user sit on the wheelchair with feet resting on the footplate. Ensure the wheel locks are engaged and the arms are locked in place. Locate the tilt handle, circled in red above, on the right arm. Stand on this side of the wheelchair.
2. To tilt the seat backward, squeeze and hold the tilt handle while pushing the back backward.
3. Release the tilt handle at the desired degree of tilt to lock into position.
4. To bring the seat back to upright position, squeeze and hold the the tilt handle while pulling upward on the push handle.

⚠ WARNING: Ensure the back is in fully upright position and the arms are locked into place before operating wheelchair.

7 ADJUSTMENTS

The PureTilt offers several adjustments to make it easier and more comfortable to operate. Section 9, MAINTENANCE, offers preventive maintenance suggestions for keeping your wheelchair in excellent condition; ensure that all components are in excellent condition before adjusting. The following are recommended methods; after a few adjustments, you may develop your own. Always consult your GF authorized distributor for assistance.

The person performing adjustments on the PureTilt has the responsibility of making certain that the user can safely operate the wheelchair with the adjustments selected. This person must evaluate the user's ability, weight, physical condition, the environment in which the wheelchair will be used, and the terrain over which the wheelchair will travel.

All adjustments and their page locations are referenced in the index at the end of this manual. Specific tools needed to perform each adjustment are identified in adjustment directions. A complete list of tools needed to perform all adjustments in this section follows:

Tools required: M5 hex key

REAR WHEELS AND CASTERS

We recommend that you do not replace or adjust rear wheel or caster components yourself, since special tools and training are required. Please contact your GF authorized distributor when your rear wheels or casters need adjustment, or if you wish to change seat height.

Info: Seat height is factory-set in the highest position. Changing seat height (wheel position) requires wheel lock adjustment.

BACK

The PureTilt back has the following features:

- Adjustable back height position
- Adjustable vertical headrest position (adjustment shown on next page)
- Foldable toward the front for transport (see **FOLDING the Wheelchair**, page 10)

Adjust Back Height

There is a lever on the right side of the back for back height adjustment, as shown at right, and seven back height positions.

1. Depress the lever and adjust the back up or down to the desired position.
2. Release the lever to lock the back into one of seven locked positions.

Info: The back pivots slightly by itself to fit the contour of your back.

⚠ WARNING: Ensure the back is locked in place before occupying or operating wheelchair.

Remove the Back

With the seat cushion removed, the back can be removed for replacement by depressing the lever and sliding the back down and off the back rails.

⚠ WARNING: Ensure the back is securely installed and locked in place before occupying or operating the wheelchair.

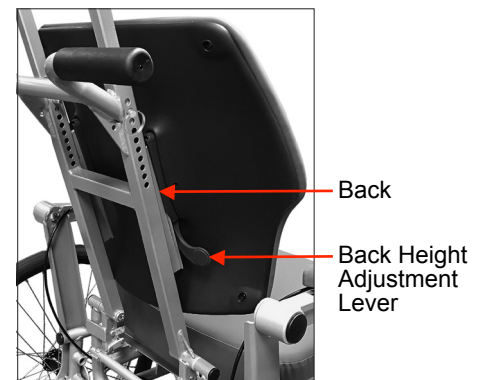

Adjust Back Height

HEADREST

Adjust Headrest Height

1. Remove the quick-disconnect pins, shown circled in red at right, from posts and headrest mounting holes.
2. Slide the headrest up or down to the desired position.
3. While holding the headrest at the desired height, align the hole in each post with the matching hole in each mounting tube.
4. Insert the quick-disconnect pins, circled in red at right, all the way through the posts and headrest mounting holes until the tension balls at the ends of the pins completely clear the tubes.

⚠ WARNING: Ensure headrest is locked in place before occupying or operating wheelchair.



Adjust Headrest Height

LEGREST / FOOTPLATE

⚠ WARNING: The footplate's lowest point should be no closer to the ground than 2 1/2 in. (6.4 cm), to permit proper clearance.

⚠ WARNING: Do not stand on the footplate; this could cause the wheelchair to tip.

⚠ WARNING: Always engage wheel locks before adjusting legrest / footplate.

Adjust Legrest / Footplate Length



There are ten legrest / footplate length adjustment location positions at 1/2 in. increments.

1. Locate the spring plunger installed through the legrest outer frame, between the calf pads, circled in red above.
2. Pull and hold the spring plunger handle and slide footplate inner frame to desired position.
3. Release the spring plunger handle to secure footplate at desired length.

⚠ WARNING: The footplate's lowest point should be no closer to the ground than 2 1/2 in. (6.4 cm), to permit proper clearance.

⚠ WARNING: Ensure footplate is locked in place before occupying or operating wheelchair.

Adjust Legrest Angle



1. Locate the legrest angle control handle on the left arm, circled in red above.
2. **To raise the legrest when it is in the vertical down position**, squeeze the handle to raise the legrest through a range to nearly horizontal; release the handle to lock the legrest into the desired position.

To lower the legrest when raised, squeeze the handle while applying pressure to the legrest and footplate to lower them to the desired position. Release the lever at the desired position.

⚠ WARNING: Ensure legrest and footplate are locked in place before occupying wheelchair; ensure legrest is locked in place in lowered position before traveling in wheelchair.

Retract Legrest for Storage or Foot Propulsion



Footplate Unfolded



Footplate Folded and Locked



Footplate Secured Beneath Calf Pads

1. Locate the spring plunger installed through the legrest outer frame, between the calf pads, circled in red at above left.
2. Pull and hold the spring plunger handle and slide footplate inner frame up to shortest length.
3. Release the spring plunger handle to secure the footplate.
4. Locate the legrest angle control handle on the left arm, circled in red at top of page.
5. To lower the legrest, depress and hold the handle while applying pressure to the legrest and footplate to lower them as far as possible until the legrest stops.
6. Release the lever to lock the legrest.
7. Fold footplate upward against the calf pads and release to lock in place, as shown at above center. For additional clearance, secure the footplate beneath the calf pads as shown at above right.

To unlock footplate, grasp both ends and lift until it folds downward.

⚠ WARNING: Ensure legrest and footplate are locked in place before occupying wheelchair.

SEAT

Seat Tilt Force

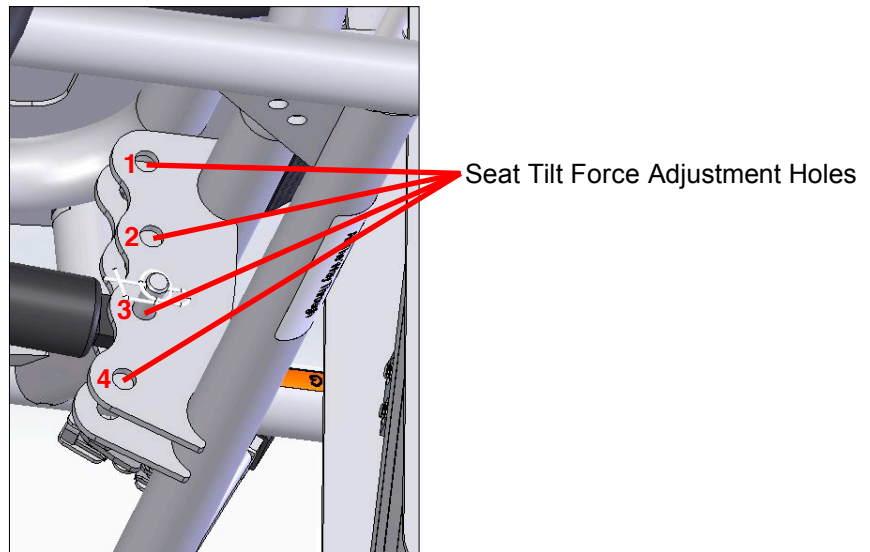

**Seat Tilt Force
Adjustment Positions**

The force required to tilt the seat while the tilt handle is squeezed is adjustable.

The seat tilt piston retaining pin can be placed in one of four different holes, as shown above. The lower the hole in which the pin is placed, the higher the effort required to tilt, and the higher the assistance provided to the user in rotating themselves to an upright position.

The ideal position for the retaining pin is based on a variety of factors such as user mass, mass distribution, and arm strength. Though the ideal setting is a comfort judgment based on the user, the following chart is given as guidance.

Seat Tilt Force Adjustment Position Chart		
Hole Number (from Top to Bottom)	User Mass Range	Approximate Tilt Angle
1	50 lb - 155 lb (22.7 kg - 70.3 kg)	5° - 40°
2	155 lb - 175 lb (70.3 kg - 79.4 kg)	5° - 35°
3	175 lb - 225 lb (79.4 kg - 102.1 kg)	5° - 30°
4	225 lb - 300 lb (102.1 kg - 136.1 kg)	5° - 25°

Info: The seat tilt force is factory-set in hole 3, as shown above.

Adjust Seat Tilt Force

- ⚠ **WARNING: DO NOT** adjust the seat tilt force, nor remove nor adjust any of the retaining pins, while the wheelchair is occupied.
- ⚠ **WARNING: The Seat Tilt Piston is under high pressure. DO NOT** twist or bend the piston in any way. **DO NOT** place hands where they could be pinned or pinched by the piston moving unexpectedly, or the seat tilting unexpectedly.

1. Ensure the wheelchair is unoccupied and in a fully upright position.
2. Squeeze the tilt handle on the right arm and press down on the push handles until the seat is tilted at least ten degrees. This will make it easier to remove the retaining pin and will also make it easier to line up the seat tilt piston with the adjustment bracket holes.
3. Place a soft material like a towel on the floor to protect the wheelchair, and place the wheelchair on its side with the tilt handle facing upward.

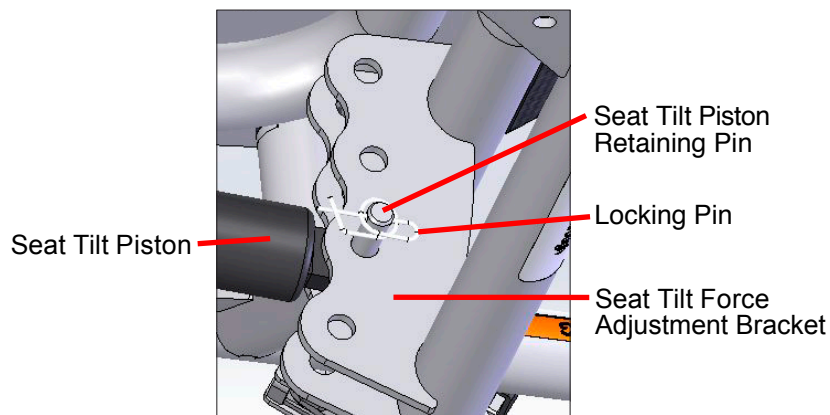

Seat Tilt Piston Retaining Pin

4. Locate the seat tilt piston retaining pin, shown above.
 5. Pull out the locking pin, shown above, from the seat tilt piston retaining pin.
 6. Pull out the seat tilt piston retaining pin; gently rock the seat up and down to assist in this.
 7. Grasping the seat tilt piston, align the front piston hole with the bracket hole of choice.
 8. Reinsert the seat tilt piston retaining pin through the bracket front hole, piston hole, and bracket back hole. **Ensure it goes completely through all these.**
 9. Reinsert the locking pin through the seat tilt piston retaining pin. **Ensure the pin is positioned so that the ring is seated around the pin as shown above.**
 10. Carefully place the wheelchair in upright position. Squeeze the tilt handle to bring the seat fully upright.
 11. **Test the wheelchair's tilt function before occupying the seat.** Do this by locking the wheel locks, squeezing the tilt handle, and pushing down on the push handles. The seat should remain at the same angle when the tilt handle is released. **Ensure the seat is brought up to an upright position before using.**
- ⚠ **WARNING: Ensure the seat tilt piston is locked in place, and the back is in fully upright position, before operating wheelchair.**

WHEEL LOCKS

Adjust wheel locks

M5 hex key



Unlocked



Locked

Wheel Lock In Unlocked and Locked Positions

1. Ensure the wheel lock is unlocked (pull the handle toward the back of the wheelchair).
2. Use the M5 hex key to slightly loosen (do not remove) the two socket head cap screws, shown at right, that secure the mounting clamp.
3. Once loosened, slide the adjustment rod that holds the wheel lock components, shown at right, to the desired position and tighten.
4. Engage the wheel lock (push the handle toward the front of the wheelchair) and measure the depth it is embedded into the tire. When engaged, the wheel lock shoe must be embedded in the tire at least 1/8 in. to 1/4 in. (.32 cm to .64 cm) to hold the tire in place.
5. Repeat steps 1 through 4, if necessary, until the 1/8 in. to 1/4 in. (.32 cm to .64 cm) measurement is obtained.

⚠ WARNING: Ensure both wheel locks are adjusted so that they lock in place appropriately before occupying or operating wheelchair.

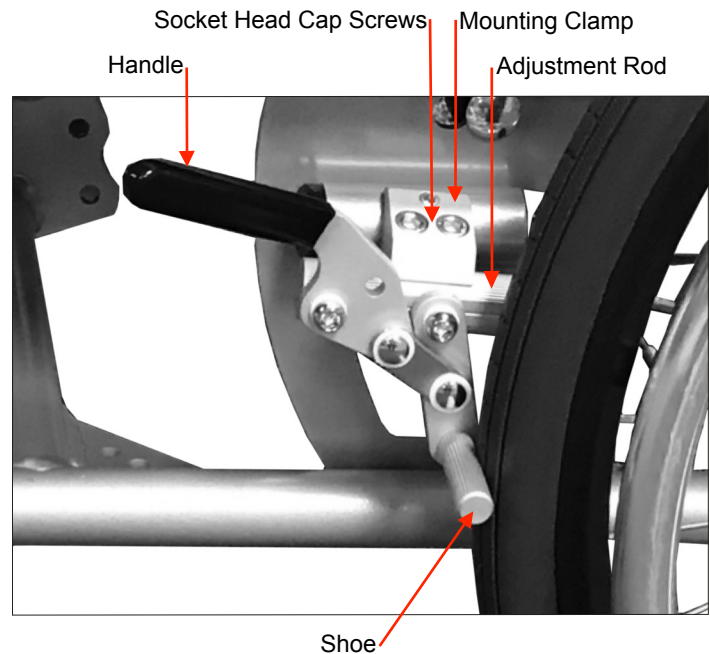

Adjust Wheel Lock (Shown Locked)

8 TRANSPORTING THE PURETILT

⚠ WARNING: This wheelchair does not offer seating or occupant restraint equivalent to the seat provided in a motor vehicle! To increase your safety while traveling in a motor vehicle, always transfer to the vehicle seat and use the restraint provided by the vehicle manufacturer.

PREPARATION FOR TRANSPORT / FOLDING THE WHEELCHAIR

⚠ WARNING: This wheelchair, with all cushions installed, weighs approximately 95 lb (43 kg); seek assistance with lifting and moving when necessary.

Fold Back Forward

See *FOLDING the Wheelchair*, page 10.

TRANSPORTING THE WHEELCHAIR

When transporting the wheelchair in a motor vehicle, do not place the wheelchair where it will interfere with the safe operation of the vehicle or endanger the driver or passengers. The front seat IS NOT a good location to store a wheelchair during transport — it can be dislodged and become a serious hazard to the driver. Always take precautions to avoid personal injury when loading or lifting a wheelchair into or out of a vehicle.

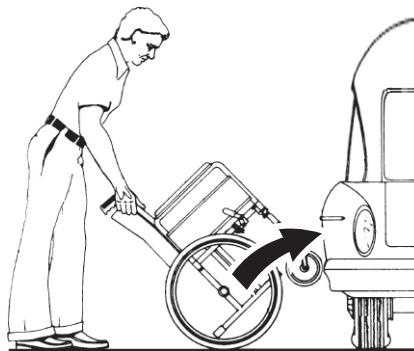

Lifting Wheelchair into Van

Van with side sliding door: Slide the side door open completely. Fold the wheelchair as described on page 10 and face it toward the open door. Tilt the wheelchair backwards as shown above and roll it forward on the rear wheels. Push the wheelchair forward so the casters enter the van. Tilt the wheelchair away from the back of the front seat, then lower the casters to the floorboard. Slowly lift-roll the chair into the van.

⚠ WARNING: Ensure the wheelchair is stable and will not shift while the van is in motion.

⚠ WARNING: Ensure the wheelchair does not block the driver's field of vision.

SUV rear door: There must be room in the back of the SUV for the wheelchair. Fold the wheelchair as described on page 10 and set the wheel locks. Grasp the front of the frame and rear of the wheels and lift the wheelchair carefully, using good body mechanics to avoid injury, and place it in the back of the SUV.

⚠ WARNING: DO NOT put any articles on top of the wheelchair.

Close the rear door slowly.

9 MAINTENANCE

Protect your E&J PureTilt by having it serviced regularly. Proper care and maintenance are essential to keep your wheelchair in safe working condition. Periodic inspection, adjustment, and replacement of worn parts will provide many years of superb performance. When you believe that a component or part of your PureTilt is not functioning properly, contact your GF authorized distributor immediately, as a potentially hazardous condition could result. Only excellent condition is acceptable where safety is concerned.

SERVICE MANUAL

There is no service manual for the PureTilt. Please contact your GF authorized distributor with questions not answered by this manual. A PureTilt parts catalog is available at www.grahamfield.com to assist in the ordering of parts.

Info: We recommend that you have a GF authorized distributor perform a six month maintenance check, as the distributor may find and correct a problem which might otherwise go undetected and eventually cause more serious problems and/or personal injury.

DO-IT-YOURSELF MAINTENANCE

You can do many of the scheduled maintenance tasks yourself, if you have mechanical ability and a few basic tools. Refer to the following maintenance schedule for the recommended regularity of each procedure. If any maintenance procedure is not clear to you, ask your GF authorized distributor for assistance.

▲ NOTICE: Improper maintenance can cause operating problem and may affect your warranty.

⚠ WARNING: Unauthorized modification or the use of non-Everest & Jennings replacement parts could change the structure of the wheelchair, void the warranty, and create a hazardous condition resulting in serious personal injury.

MAINTENANCE SCHEDULE				
Procedure	Perform at least every			
	Week	Month	3 Months	6 Months
Check tire wear	✓			
Check handrims	✓			
Check wheel lock engagement	✓			
Check anti-tippers (optional)	✓			
Wipe off frame	✓			
Check handgrips		✓		
Check upholstery		✓		
Clean upholstery and plastic components		✓		
Check rear wheel adjustment		✓		
Check arms		✓		
Check arm and back locking latches		✓		
Check legrest and footplate		✓		
Clean frame			✓	
Check caster axle and stem rotation			✓	
GF distributor maintenance check				✓
Check caster and rear wheel bearings (distributor)				✓

List of tools

The tools and cleaning supplies listed will assist in the procedures outlined in this section.

30 weight oil (available at most auto parts stores)

M5, 9/64, and 7/64 hex keys

soft cloth

mild soap and water solution

General care

Always evaluate the overall operation of your wheelchair. It should function with ease and should travel straight without excessive drag or pull to one side.

Remember, your GF authorized distributor knows your wheelchair best when it comes to service and repairs. Contact your distributor with any questions or concerns regarding the safe operation and maintenance of your wheelchair. Regular maintenance is essential for your safety and continued operation of your wheelchair.

CHECK AT LEAST EVERY WEEK

Check tire wear

Examine tires at least once a week for surface wear and cracks and replace them as needed. Replace tires when they become loose on the rims or cracks appear.

Check handrims

Check handrims at least once a week. Inspect each handrim for rough or sharp edges and, if any are found, replace wheel immediately. Ensure all hardware is properly aligned and secure.

Check wheel lock engagement

Check wheel lock engagement at least once a week. See ***Adjust wheel locks*** in Section 7 to adjust wheel lock engagement. If a wheel lock is worn or damaged, replace it immediately. Inspect the hardware for looseness or signs of wear.

Ensure the locking mechanism operates smoothly. The locking assembly should be tight enough so that the wheel can not rotate or the lock slip. Check that the locking shoe does not press against the tire when in the unlocked position. Excessive force should not be required to either engage or release wheel locks. Oil the wheel lock pivot points with one or two drops of 30 weight oil. Remove excess oil and dirt.

Check anti-tippers

Check the anti-tippers at least once a week. Ensure the anti-tippers are securely fastened and properly positioned.

⚠ WARNING: When in use, anti-tippers must be installed in the downward position.

Wipe off frame

Wipe off the frame frequently, at least once a week, using a soft cloth. Dry the wheelchair immediately if exposed to moisture.

CHECK AT LEAST EVERY MONTH

Check handgrips

Check handgrips at least once a week. Ensure that they are not ripped; ensure that they are tight and securely fastened.

Check upholstery

Check upholstery at least once a month. Inspect for rips, tears and worn spots. Ensure hook and loop fastener is firmly attached to metal surfaces and backs of pads.

⚠ WARNING: Worn or torn upholstery must be replaced immediately.

Clean upholstery and plastic components

Clean upholstery and plastic components at least once a month with a mild soap and water solution.

Check rear wheel adjustment

Inspect the rear wheels at least once a month. Check alignment by elevating the rear of the wheelchair on a stable object until the rear wheels clear the ground, or placing the wheelchair upside down in a stable position such that the wheels can spin freely. Spin the wheels; there should be no wobble or sideplay, and the wheels should spin freely without binding. The bearings should be clean and rotate smoothly. Check rim sideplay to verify that bearings are not too loose. If there is a problem, contact your GF authorized distributor. If adjustment is required, this should be done by your distributor only.

Check arms

Check arms at least once a month. Inspect for rips, tears, or worn spots, and replace if found. Ensure all attaching screws are present and tight. Use a $7/64$ hex key to tighten arm pad mounting screws from underneath.

Check arm and back locking latches

Check arm and back locking latches at least once a month to ensure screws are tight. Tighten with $9/64$ hex key if needed.

Check legrest and footplate

Check footplate and legrest at least once a month. Inspect the locking mechanisms to confirm sure fit. Check for cracks, burrs, or sharp edges, and replace if found. Ensure that footplate and legrest will lock securely in place and will not accidentally unlock.

CHECK AT LEAST EVERY THREE MONTHS

Clean frame

Clean the frame at least every three months with a mild soap and water solution. The frame does not need to be waxed. Do not use solvents, abrasive waxes, caustic chemicals or spray silicone on the frame. Never use abrasive cleansers; they could scratch the finish. Never use steam or high pressure cleaners.

Check caster axle and stem rotation

Check the caster axles for proper rotation at least every three months. Ensure the stems are firmly attached to the forks and that the forks and stems are not bent. The caster axles must turn freely, and the caster forks must swivel freely, to facilitate steering and handling. Evaluate all threads and locking nuts. If the caster axles require adjustment, contact your GF authorized distributor.

CHECK AT LEAST EVERY SIX MONTHS

Maintenance check

Have your GF authorized distributor perform a maintenance check at least every six months.

Check caster and rear wheel bearings

Have your GF authorized distributor check caster and rear wheel axle bearings at least every six months.

10 TROUBLESHOOTING

Continual use of your PureTilt necessitates maintenance, especially if the factory-set adjustments have been altered. The following troubleshooting guide lists several common problems that may occur, and offers corrective actions for each. If you are unsure of the solution or unable to diagnose the problem, do not hesitate to ask your GF authorized distributor for assistance.

Symptom	Problem	Solution
The seat is not tilting when the tilt handle is squeezed	The pin in the end of the cylinder is not being depressed	Ensure the cable is attached to the cylinder actuator
The legrest is not moving when the plunger switch is squeezed		Ensure the cable is not pinched or damaged
Wheelchair is difficult to move	Wheel locks are not fully disengaged	Ensure wheel locks are fully disengaged
	Bearings are faulty	Have GF authorized distributor check front caster and rear wheel bearings
Rear wheel locks do not lock	Wheel locks not properly mounted on lower frame	See Adjust Wheel Locks , page 22; follow steps for both rear wheels.
Note: if you are unable to solve a problem, contact your GF authorized distributor.		

Info: Use only Everest & Jennings replacement parts. A PureTilt parts catalog is available at www.grahamfield.com to assist in the ordering of parts.

- ⚠ **CAUTION: A complete inspection of your wheelchair, including maintenance, servicing and safety checks, should be performed by a GF authorized distributor at least every six months.**
- ⚠ **WARNING: Unauthorized modification or the use of non-Everest & Jennings replacement parts could change the structure of the wheelchair, void the warranty, and create a hazardous condition, which could result in serious personal injury.**

11 SPECIFICATIONS

Info: Dimensional tolerance: angles $\pm 2^\circ$, lengths $\pm .5"$ (1.3 cm)

MODEL NAME / NUMBER		PT3000-18
Overall length	upright	39.8" (101.0 cm)
	reclined	50" (127.0 cm)
Overall width		28.5" (72.4 cm)
Storage length (back folded)		39.5" (100.3 cm)
Storage height (back folded)	with seat	36" (91.4 cm)
	without seat	29.5" (74.9 cm)
Seat tilt angle		5° to 40°
Seat depth		21" (53.3 cm)
Seat width		19.8" (50.2 cm)
Seat height (at front of seat)		19.75" (50.1 cm) or 21.75" (55.2 mm)
Foot support to seat	retracted	13" (33.0 cm)
	extended	17.5" (44.5 cm)
Leg to seat angle (from horizontal)		-97° to 15°
Arm height	from seat front	5.8" (14.6 cm)
	from seat rear	7.5" (19.1 cm)
Rear wheel		22.0" (55.9 cm) diameter with aluminum handrim
Front caster		6.0" (15.2 cm) diameter
Environmental operating conditions		32 °F to 100 °F (0 °C to 38 °C)
Maximum weight capacity, EVENLY DISTRIBUTED		300 lb (136.1 kg)
Wheelchair standard met		ISO 7176:1989-2014 Series Standards Parts 1, 3, 5, 7, 8, 11, 13, and 15
		ANSI/RESNA WC-1:2019 Series Standards Sections 1, 3, 5, 7, 8, 11, 13, and 15
Upholstery fabric standard met		Flame retardant per ANSI/RESNA WC-1:2009, Section 16
Total product mass		90 lb (40.8 kg) without cushions; 95 lb (43.1 kg) including all cushions

For further information, call Graham-Field Customer Service at 1.770.368.4700.

12 DISPOSAL

Dispose of wheelchair in accordance with local regulations.

13 LIMITED WARRANTY

SCOPE OF WARRANTY

GF Health Products, Inc. ("GF") warrants to the Original Purchaser only that it will replace or repair components, at GF's sole discretion, that are defective in material or workmanship under normal use and service. All warranties are conditioned upon the proper use of the products strictly in accordance with good commercial practice and applicable GF instructions and manuals, including proper use and maintenance. To the extent that a third party warrants a component, GF conveys all of its rights under that warranty to the Original Purchaser, to the extent permitted. Original Purchaser is one who purchases this product new and unused from GF or a Certified GF Dealer/Distributor.

This limited warranty shall only apply to defects that are reported in accordance with the provisions set forth in this warranty document, within the applicable warranty period and which, upon examination by GF or its authorized representative, prove to be a warranty item. (See Obtaining Warranty Service below) This limited warranty is not transferable.

The warranted components and time period are set forth below:

- Main frame, seat frame, back frame:.....five (5) years
- Rear wheels, casters, legrest, footplate:.....one (1) year
- All other durable components not listed above:.....six (6) months

* Labor is not included in the warranty.

† The warranty period is as designated above. If a part is replaced under warranty, the original warranty period will not be affected. All other replacement parts will be subject to the warranty period specified.

The applicable warranty period shall commence from date of shipment to the Original Purchaser, unless there is an expiration date on the component in which case the warranty shall expire on the earlier of warranty period or the expiration date.

OBTAINING WARRANTY SERVICE

Contact the Dealer/Distributor from whom the product was purchased. If there is not a Dealer/Distributor, you must contact GF directly by calling (770) 368-4700 or by e-mailing a request to cs@grahamfield.com. The Customer Service Representative will provide specific directions. Failure to abide by the specific directions will result in denial of the warranty claim.

The warranty does not cover and GF shall not be liable for the following:

- 1) Defects, damage, or other conditions caused, in whole or in part, by misuse, abuse, negligence, alteration, accident, freight damage, tampering or failure to seek and obtain repair or replacement in a timely manner;
- 2) Products which are not installed, used, or properly cleaned and maintained as required in the official manual for the applicable product;
- 3) Products considered to be of a non-durable nature including, but not limited to: filters, fuses, gaskets, lubricants, and charts;
- 4) Accessories or parts not provided by GF;
- 5) Matching of color, grain or texture except to commercially acceptable standards;
- 6) Changes in color caused by natural or artificial light;
- 7) Charges by anyone for adjustments, repairs, replacement parts, installation or other work performed upon or in connection with such products which are not expressly authorized in writing, in advance, by GF;
- 8) Any labor or shipping charges incurred in the replacement part installation or repair;
- 9) Costs and expenses of regular maintenance and cleaning; and
- 10) Representations and warranties made by any person or entity other than GF.

ENTIRE WARRANTY, EXCLUSIVE REMEDY AND CONSEQUENTIAL DAMAGES DISCLAIMER

TO THE GREATEST EXTENT PERMITTED BY LAW, THIS WARRANTY IS GF'S ONLY WARRANTY AND IS IN LIEU OF ALL OTHER WARRANTIES, EXPRESS OR IMPLIED. EXCEPT IN CASES WHERE IMPLIED WARRANTIES MAY NOT BE VALIDLY WAIVED, GF MAKES NO IMPLIED WARRANTIES OF ANY KIND INCLUDING ANY IMPLIED WARRANTIES OF MERCHANTABILITY OR FITNESS FOR A PARTICULAR PURPOSE. IF ANY MODEL OR SAMPLE WAS SHOWN TO THE CUSTOMER, SUCH MODEL OR SAMPLE WAS USED MERELY TO ILLUSTRATE THE GENERAL TYPE AND QUALITY OF THE PRODUCT AND NOT TO REPRESENT THAT THE PRODUCT WOULD NECESSARILY CONFORM TO THE MODEL OR SAMPLE IN ALL RESPECTS. THIS WARRANTY IS LIMITED TO THE REPAIR OR REPLACEMENT OF THE DEFECTIVE PARTS. GF SHALL NOT BE LIABLE FOR AND HEREBY DISCLAIMS ANY DIRECT, SPECIAL, INDIRECT, INCIDENTAL, EXEMPLARY OR CONSEQUENTIAL DAMAGES, INCLUDING, BUT NOT LIMITED TO: DAMAGES FOR LOSS OF PROFITS OR INCOME, LOSS OF USE, DOWNTIME, COVER, OR EMPLOYEE OR INDEPENDENT CONTRACTOR WAGES, PAYMENTS AND BENEFITS. CERTAIN STATES AND COUNTRIES MAY CONFER ADDITIONAL RIGHTS REGARDING WARRANTIES AND IN THOSE INSTANCES, GF'S LIABILITY AND THE LIABILITY OF GF'S SUPPLIERS, SHALL BE LIMITED TO THE FULLEST EXTENT PERMITTED BY LAW.

The warranties contained herein, together with GF's current Terms and Conditions, contain all the representations and warranties with respect to the subject matter of this document, and supersede all prior negotiations, agreements and understandings with respect thereto. The recipient of this document hereby acknowledges and represents that it has not relied on any representation, assertion, guarantee, warranty, collateral contract or other assurance, except those set out in this document.

For additional information on this product or this warranty, please contact a GF Customer Service Representative.

NOTES:

- 1) Additional terms and conditions may apply. See GF's General Terms and Conditions on its website: www.grahamfield.com.
- 2) Freight claims must be notated on the appropriate shipping documents and must be made with immediacy. International, federal and state regulations govern specific requirements for freight claims. Failure to abide by those regulations may result in a denial of the freight claim. GF will assist you in filing the freight claim.
- 3) Claims for any short shipment must be made within three (3) days of the invoice date.

14 INDEX

A

Adjustments 17
Anti-tippers, check 25
Anti-tippers, installing and operating 9
Arm locking latches, check 26
Arms, check 26
Arms, rotating 15

B

Back 17
Back, adjust height 17
Back locking latches, check 26
Back, remove 17
Balance 11

C

Casters, adjust 17
Casters, check 26
Casters, installing 8
CAUTION statement, significance 3
Curbs and steps 13
Curbs — with attendant 14

D

Disposal 29

F

Footplate, check 26
Frame and upholstery, clean 26
Frame, wipe off 25

G

Getting started 8

H

Handgrips, check 25
Handling tips 11
Handrims, check 25
Headrest, adjust height 18
Headrest, install 9

I

Info statement, significance 3
Intended use 3
Introduction 3

L

Labels, PureTilt 7
Legrest, adjust angle 19
Legrest, adjust length 18
Legrest, check 26
Legrest, retract for storage or foot propulsion 19

M

Maintenance 24
Maintenance, check at least every month 25
Maintenance, check at least every six months 26
Maintenance, check at least every three months 26
Maintenance, check at least every week 25

N

NOTICE statement, significance 3

O

Operating seat tilt: by caregiver 16
Operating seat tilt: by user 16
Operation 15

P

PureTilt®, illustration 6

R

Ramps and Inclines 13
Reaching / bending 12
Rear wheel adjustment, check 26
Rear wheels, adjust 17

S

Safety precautions 4
Seat tilt force 20
Seat tilt force, adjust 21
Seat tilt, operating 16
Specifications 28
Statements of significance 3

T

Tires, check 25
Tools, for adjustment, list 17
Tools, for maintenance, list 25
Transfer activities 11
Transporting the PureTilt 23
Troubleshooting 27

U

Upholstery, check 26

W

Warnings 4
WARNING statement, significance 3
Warranty, limited 30
Weight capacity, maximum 4
Weight training 14
Wheel bearings, check 26
Wheel lock engagement, check 25
Wheel locks, adjust 22

Everest & Jennings®

by graham-field



Manufactured By:
GF Health Products, Inc.
One Graham-Field Way, Atlanta, GA 30340
Made in U.S.A.

© 2021, GF Health Products, Inc. All Rights Reserved.
Everest & Jennings is a registered trademark of
GF Health Products, Inc. PureTilt is a trademark of Proactive
Comfort, LLC, Chantilly, VA 20151

EJ_PT3000-18-INS-LAB-RevE23



+1 770.368.4700

Information contained herein is subject to change without notice.
The most current and complete product information can be found on our website.
www.grahamfield.com

