



BRASS MONKEY®

Ice Bath Quickstart Guide





“This—Sh*t—Works”

Wim Hof

- How it works4
- Getting set up5
- Install the filter6-7
- Filling the bath..... 8-9
- What the controls do.....10-11
- Cleaning and maintenance12-13
- Changing the filter..... 14-15
- Changing the UV Bulb.....16-17
- Cleaning FAQ’s 18
- Troubleshooting..... 19
- High usage recommendations.....20
- Using Huwa-San21-22
- Full system flush..... 23
- Going on holiday 25
- Operator responsibility and safety recommendations 26
- Health and safety user recommendations27
- Contact 28

How it works



Easy to maintain

We design the baths to be as maintenance light as possible. The cleaning guidelines will largely depend on the environment that the bath is in and the level of usage.

The maintenance will consist of changing the filter and UV bulb. Depending on usage you should only need to change the filter every 4 weeks and the UV bulb once a year. To ensure your water stays clean for as long as possible we'd always recommend taking a quick shower before jumping in your ice bath!

Patented Ice Cycles

Yes you've read that right. Our patented technology means our ice baths & plunges run what we call ice cycles. We freeze the base of the bath and release it in cycles, this creates 15-30mm ice sheets that break up easily and means your ice bath can drop to zero degrees with ice in. Ice cycles will begin when the bath is set to below 1°C.

Intelligent and app connected

Our ice baths are designed to ensure you can just say focussed on your immersion. We have 6 sensors all feeding into our software to ensure temperature control and ice formation is as energy efficient and precise as possible. Using our companion app you can schedule your bath to be ready when you want it to be bringing further efficiency to your bath. Once your bath is online we can monitor the performance and automatically send updates over the air.

Getting set up

- 1. Download the Brass Monkey app**
Create an account and add your device, then scan the QR code on the unit
- 2. Install the filter cartridge**
This is the filter in the accessories pack and sits in the big grey filter housing, instructions on page 8
- 3. Fill it up with water**
Using a hosepipe, fill to just above the inlet, the grey circular fitting towards the top right in the bath
- 4. Bleed the filter**
Release any air locks by turning the air relief key at the top of the filter housing
- 5. Plug it in**
Just plug in to a normal socket on an RCD protected circuit. The bath will now start cooling to 0.6°C - you can set the required temp on the app or from the control panel. Time to get your cold on!

You will need

- Filter cartridge
- Hosepipe
- Your smart phone

Tips

- Leave the bath switched off whilst setting up
- Don't use an extension cable
- Use clean water from the tap
- Typically it will take around 24 hours for your bath to get down to 0°C

Install the filter

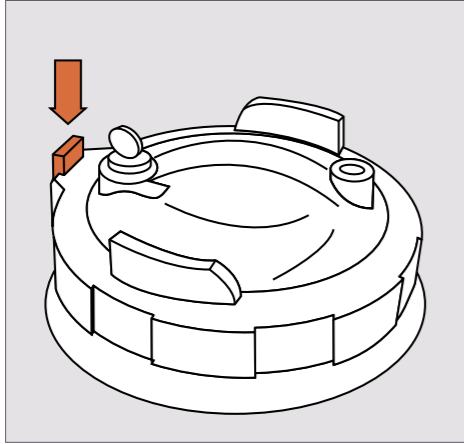

Step one

Locate the lid of the filter housing and lift the tab as shown above.

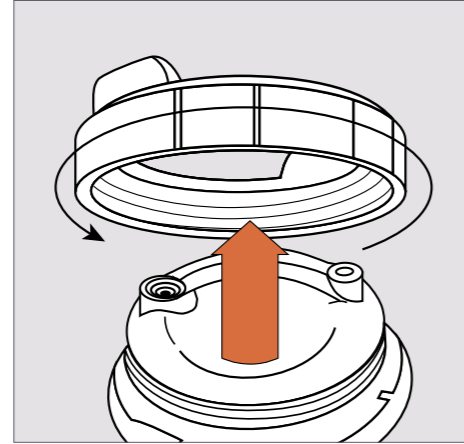

Step two

Now you can unscrew the collar and remove.

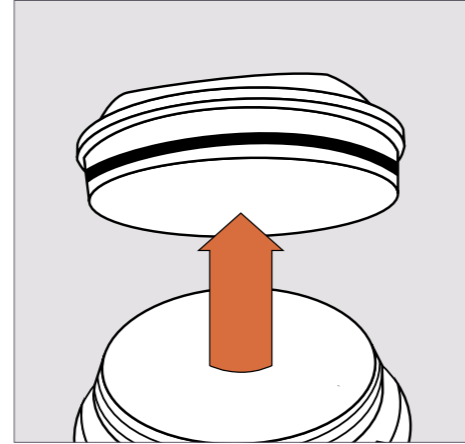

Step three

Pull firmly on the handle to release the lid.

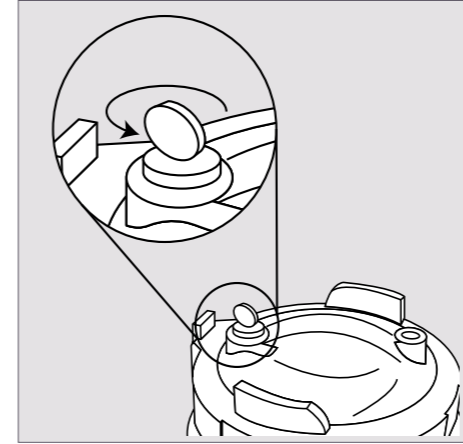

Step four

If it is tight release air by slightly unscrewing the air relief key. Do not remove it.

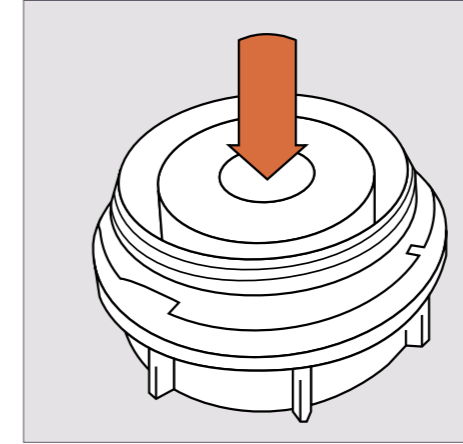

Step five

Pop the white paper filter in so that it secures into the fitting at the base of the filter housing.

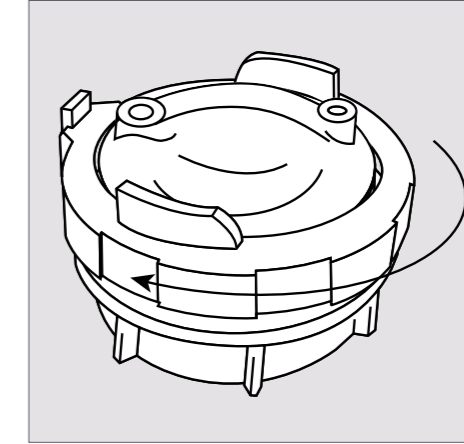

Step six

Replace the collar by rotating the outer ring clockwise until the tab clicks into place. Do not over-tighten.

Leave the bath unplugged whilst setting up

Filling the bath

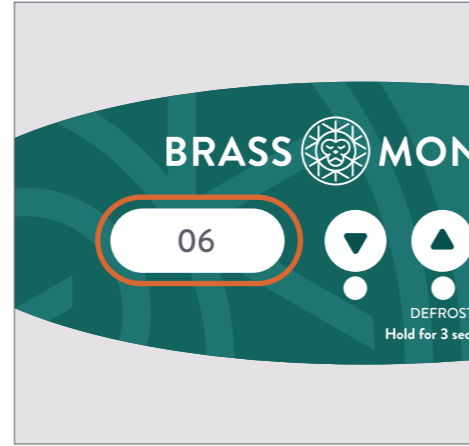
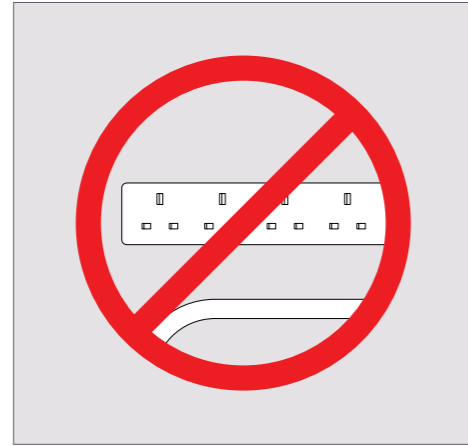
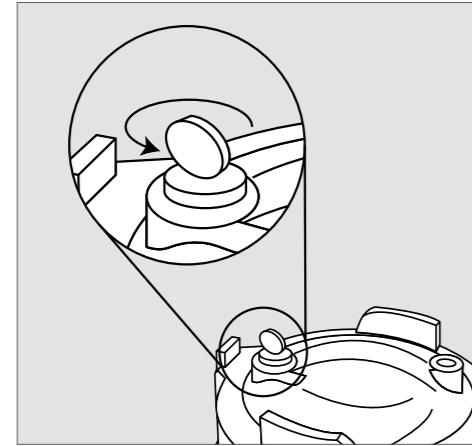
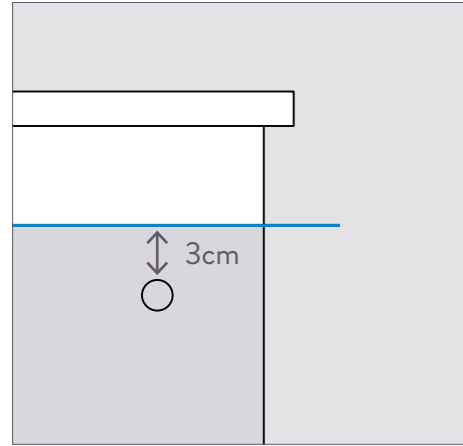

Step one

Fill the bath from a clean tap water supply to 3cm above the water outlet, allowing for some water displacement when you get in.

Step two

When the bath is filled to the correct level, bleed any air out of the filter by loosening the air relief key on the filter until all air has escaped. Then you can tighten it back up.

Step three

Plug the bath in and switch it on. The power supply should be connected to an RCD circuit. We **do not** advise using extension cables.

Step four

Set your desired temperature from 10°C down to as low as 0°C. If you would like ice to be created within the bath set it to 0.6 °C.

Important!

Do not bleed the filter whilst the power is on as this can cause air locks which result in an inefficient filter.

Do not remove the air relief key completely or the black washer that seals the key - this can result in filter malfunction.



The bath can take up to 24 hours to get down to freezing temperatures. When it is down to temperature, toggle up and down by 0.1°C to achieve your desired level of ice.

What the controls do

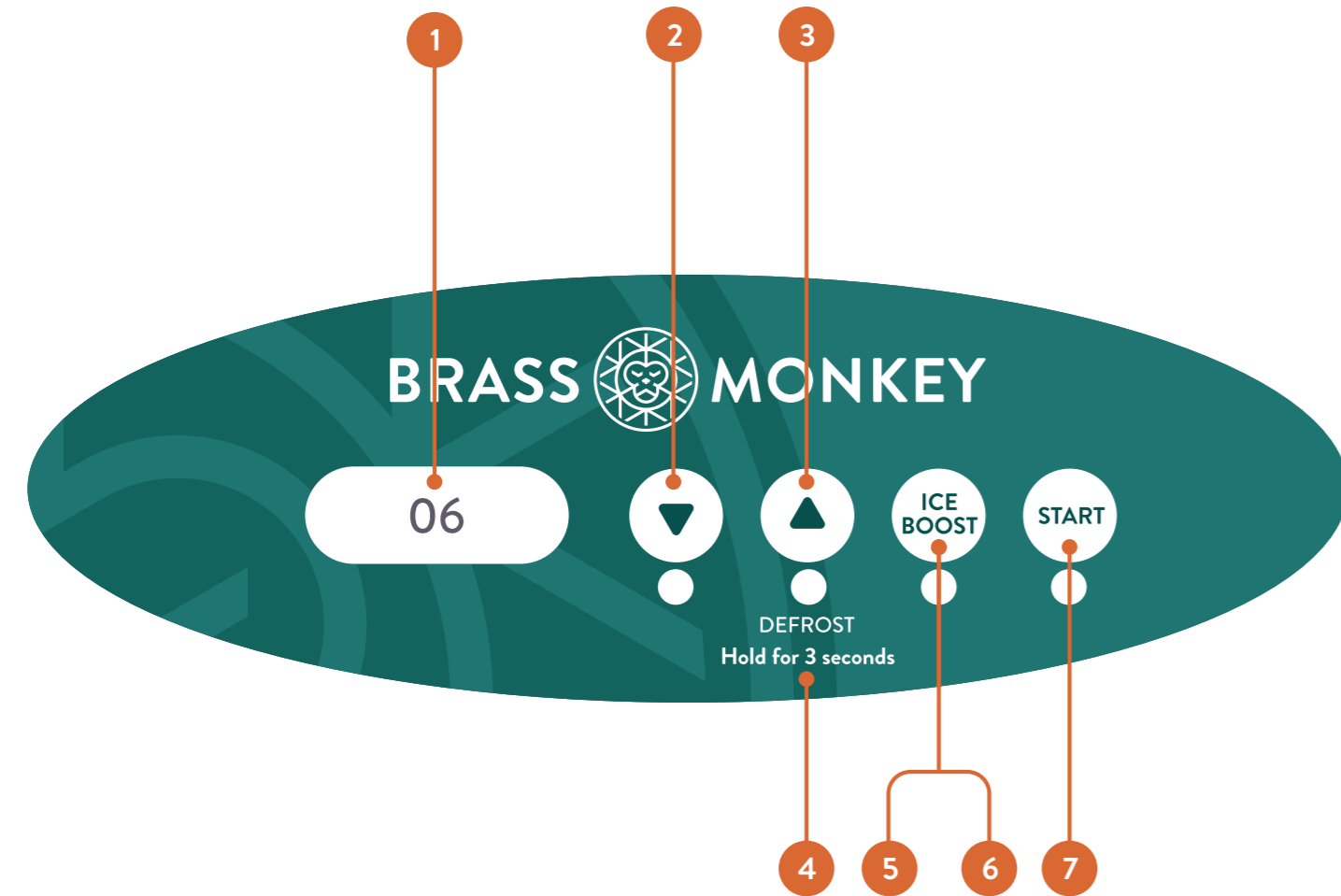

1	Temp Display	10°C is displayed as 100. 1°C is displayed as 10. 0.1°C is displayed as 01.
2	Temp down	The lowest temp setting is 0°C displayed as 00.
3	Temp up	The highest temperature setting is 10°C. Note: the bath will not heat up, if you toggle temp up it will stop cooling and the water will naturally get warmer.
4	Defrost mode	Press and hold the up arrow for 3 seconds to put the bath into a defrost mode for 30 minutes - this will release any ice on the bottom of the bath. Press and hold again to exit defrost mode.
5	Ice Boost	Use Ice Boost when the temperature is set below 0.5°C and the bath idle i.e. not cooling - the bath will then perform 8 additional sheets over approximately 8 hours.
6	Maintenance Mode	Press and hold ICE BOOST for 3 seconds to put the bath into a maintenance mode - The light in the bath will flash 3 seconds on 3 seconds off whilst in this mode. From here you can change the filter, the UV bulb and empty the water. Don't forget to exit maintenance mode by pressing and holding ice boost for 3 seconds again.
7	User start mode	This will begin a session in the bath. It switches everything off for a peaceful experience and ensures that any ice on the base of the bath is defrosted. When the light in the bath is solid blue it is safe to get in the bath. If the blue light in the bath is flashing it means a defrost cycle is necessary. This will run for 7-8 minutes and will then revert to solid blue meaning it is now safe to get in the bath.

Cleaning and maintenance

The bath will require regular cleaning to ensure the smooth running of the equipment and to maintain and lengthen the water quality.

How the cleaning process works

The bath has a dual stage filtration system consisting of a sediment filter and a UV filter. The water in your bath constantly circulates through both of these. The filters job is to keep the water clear and the UV's job is to keep the water free of pathogens. If there is a blockage in the flow due to lack of cleaning you will find the bath will not work efficiently; the water will stop circulating and it will become dirty.

The frequency at which you will need to change the filter and the water depends on usage and how much bacteria and debris is introduced into the bath. For 1 daily user, our recommendations are in the table on the right.

Action	Frequency
Wipe down the leatherette cover	Regularly
Wipe away debris from the pre-filter inside the bath	Once per week
Change the filter	Every 4 weeks
Change the water and fully clean the bath	Every 2-3 months
Full system flush	Every 6 months
Change the UV bulb	Once per year

Filter & UV bulb replacements can be purchased at www.brassmonkey.co.uk

Important!

Wipe away debris from the pre-filter

The pre-filter is there to catch larger items before being circulated into the filtration system. It is good practice to reach into the water with a soft clean cloth and catch any debris that is caught on the pre-filter. In doing this, the water will circulate smoothly. If it gets clogged, you will find that the water quality will deteriorate and the water will struggle to flow around the unit. It may eventually stop if it gets blocked.

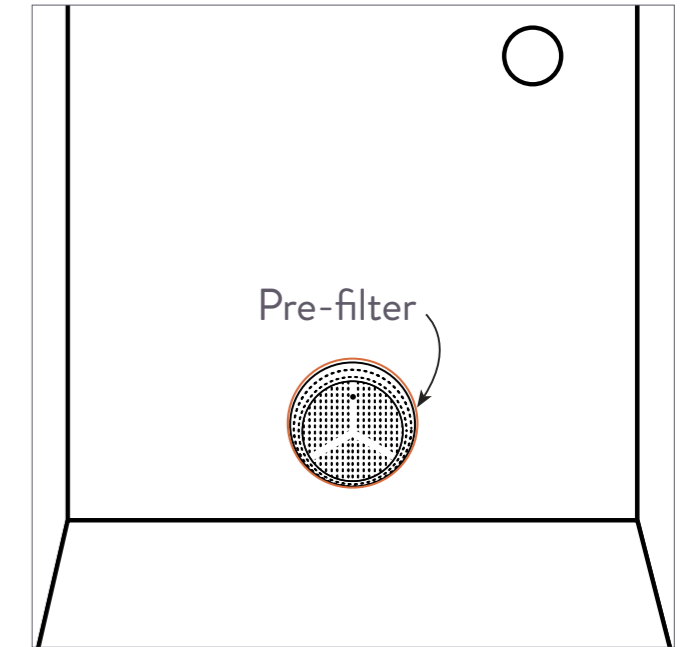

Changing the filter

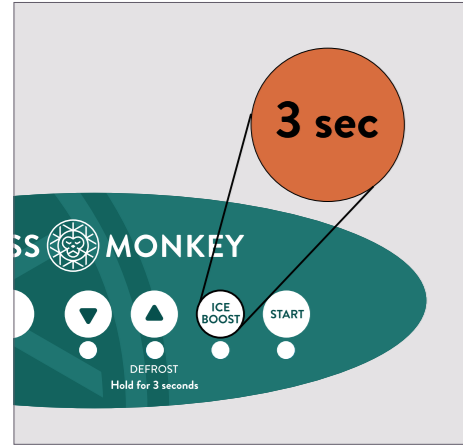

Step one

Put the bath into maintenance mode by pressing and holding “Ice Boost” for 3 seconds (everything will switch off).

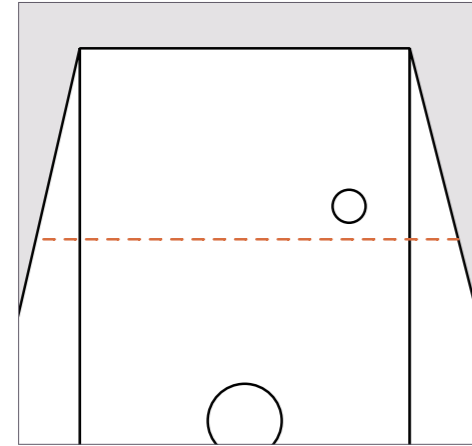

Step two

Partly drain the water with a submersible pump so that it is below the water inlet level.

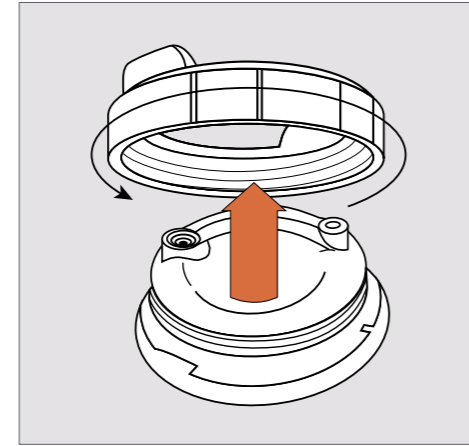

Step three

Remove the lid of the filter housing - lift the tab and unscrew the outer collar.

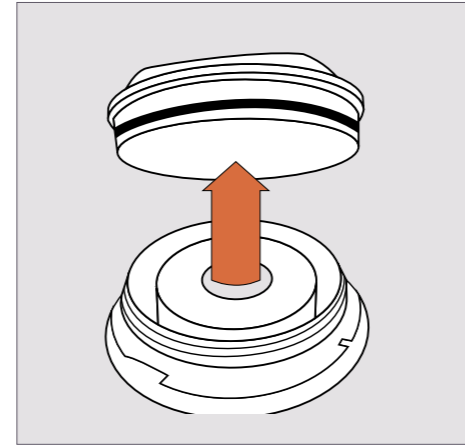

Step four

Pull firmly on the handle to release the lid and remove the current filter

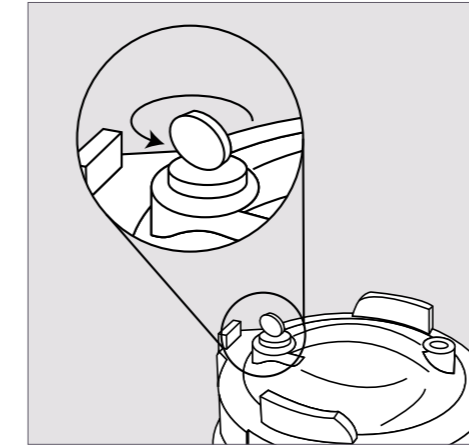

Step five

If it is tight release air by slightly unscrewing the air relief key. Do not remove it.

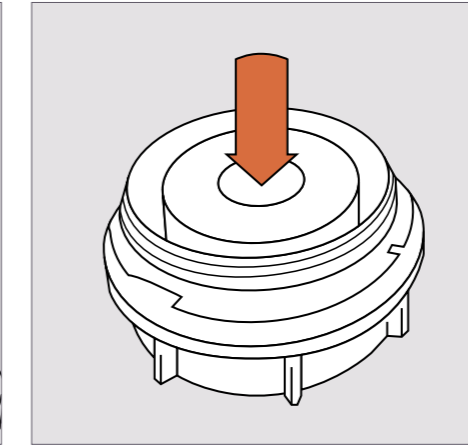

Step six

Replace the filter with a clean one ensuring it is securely located to the fitting at the base of the filter housing.

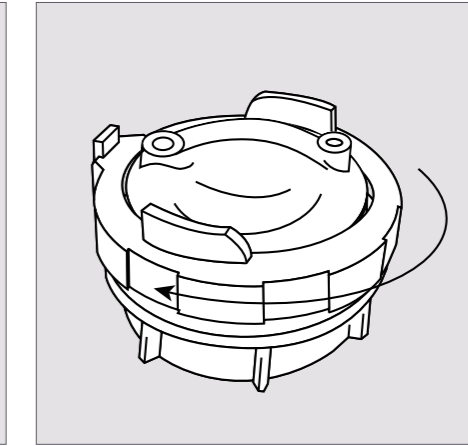

Step seven

Replace the collar by rotating the outer ring clockwise until the tab clicks into place.

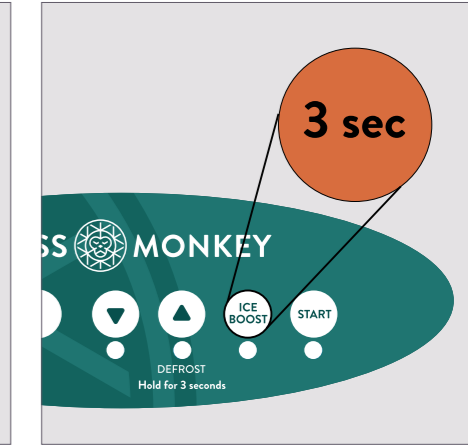

Step eight

Exit maintenance mode by pressing and holding “Ice Boost” for 3 seconds. The bath will now begin running again.

Changing the UV bulb

The bath must either be in maintenance mode or switched off to perform this function.

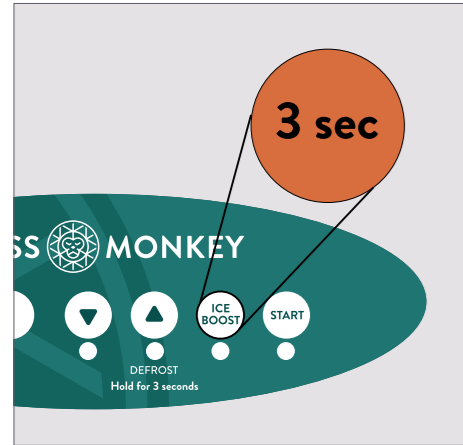

Step one

Put the bath into maintenance mode by pressing and holding “Ice Boost” for 3 seconds (everything will switch off).

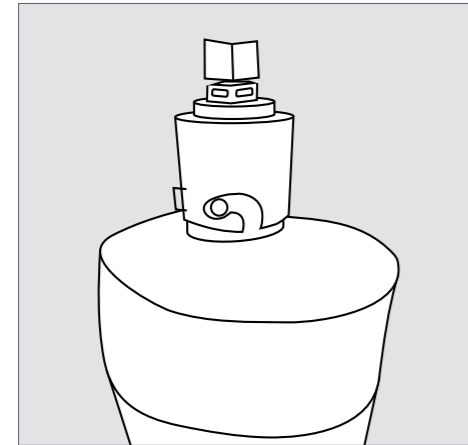

Step two

Locate the UV bulb chamber.

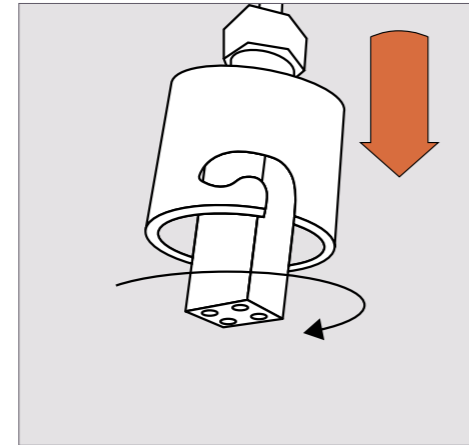

Step three

Push down the chamber cap and turn anti-clockwise until it releases. Put to one side.

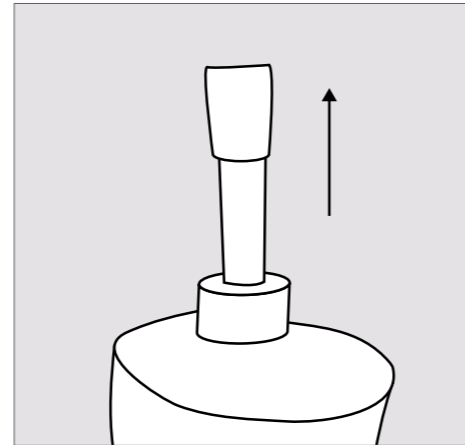

Step four

Remove the bulb.

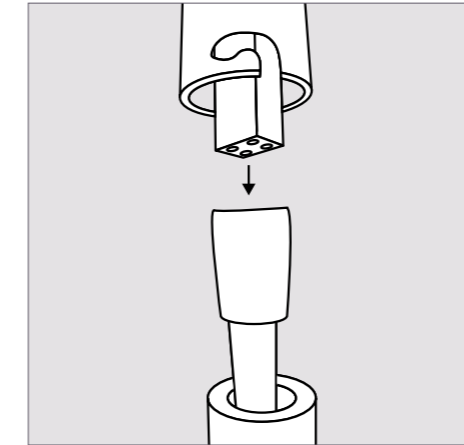

Step five

Insert the new UV bulb, gently lowering the bulb halfway in. When it is halfway you can affix the chamber cap onto the uv bulb with the 4 pins on the bulb located into the holes on the chamber cap.

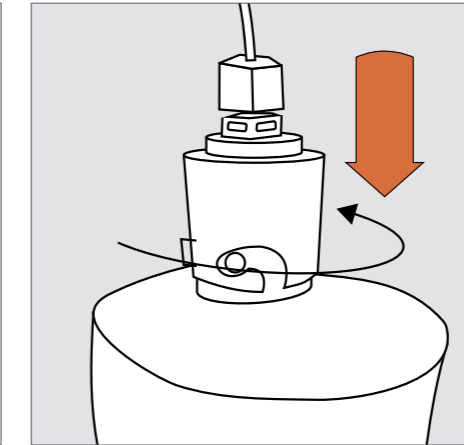

Step six

Now secure the chamber cap by locating it back into the unit - push down and turn slightly until it locks into position.

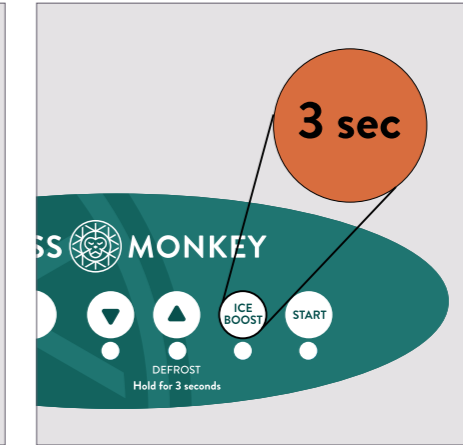

Step seven

Exit maintenance mode by pressing and holding “Ice Boost” for 3 seconds. The bath will now begin running again.

Cleaning FAQ's

Where can I buy spare filters?

You can buy the filters from our website www.brassmonkey.co.uk/accessories

How do I empty the bath?

You can do this with a submersible pump - available on Amazon. Attach it to your hosepipe and either drain the water down a drain or into the garden.

What do I clean the inside of the bath with?

Huwa San TR3 or any food grade hydrogen peroxide 3%.

Can I use chemicals in the bath?

You cannot use chlorine or bromine or any other harsh chemicals in the bath as it will deteriorate the steel which will rust and break down eventually.

We recommend the use of Huwa - San which is silver stabilised hydrogen peroxide. This breaks down into water and oxygen when used in the bath and creates no nasty by-products.

This can be purchased from Brass Monkey orders@brassmonkey.co.uk

Troubleshooting

Common problems and actions recommended.

Problem	Possible causes	Actions
Water is murky	Filter change required	Check water flow is flowing. Remove half the water from the bath and replace the filter.
	Lost seal in bleed key	Check the air relief key still has its black seal, keeping the pressure in the filter housing.
	Air released from air relief key whilst bath is switched on	This will cause an airlock and the filter will not be fully in use. Enter maintenance mode and then bleed the filter.
Ice is stuck	Temperature is set too low	Press defrost, wait 30 minutes for the ice to release and then set to 0.6°C and wait 24hrs -reduce by 0.1 of a degree every 24 hours If the ice is too thin or too thick, please email support@brassmonkey.co.uk
Water is cold but there is no ice	Insulated cover not being used at all times	Ensure the cover is always on the bath - ice will melt quickly if this is not used.
	Temp not set low enough	Set the bath to 0.6°C
	Potential ice stuck on the base of the bath	You may have a slab of ice on the base of the bath that needs releasing - follow Ice stuck protocol above.
No water flow	Filter is dirty and blocked	Change the filter.
Buttons not working	Ice bath is performing the defrost function	The Start button will not work if the bath is performing a defrost cycle or if a defrost is required to release ice. Wait for the defrost to complete and then press the Start button. If the blue light flashes, it is releasing ice from the base of the bath. When solid blue you can get in.

High usage recommendations

If you have high usage (8-10+ people per day using the bath) you may want to use a residual cleaner such as Huwa-San.

Huwa-San TR-5 disinfects water, kills legionella, destroys other bacteria and helps to remove biofilm, body oils, fat and grease.

Need to know:

1. 99% of people do not need it, if you have very high usage of the ice bath it can be considered.
2. It does not mitigate filter change - it's a "third line of defence" residual cleaner - so it won't remove green water, it can only slow the build of it
3. It's better than chlorine (no nasty by-products) as it breaks down to water and oxygen (Eco product) - chlorine also does not work with UV!
4. Silver stabilised means it hangs in the water longer than standard food grade hydrogen peroxide.
5. The target is 500ppm mix - monitored via dip strips - without dip strips you cannot monitor it. The lowest ever mix should be 300ppm, anything less is pointless.

Using Huwa-San

Step one Fully drain and then refill the ice bath so you're starting with fresh water.

Step two Add enough Huwa-San TR-5 to achieve 500ppm hydrogen peroxide. Circulate around the system and leave in place for at least 12 hours. Here's how to work out the volume of Huwa-San TR-5 that you will require.

Type of Ice Bath	Amount of Huwa-San TR-5
Ice Bath 275 L capacity	2 litres
Ice Plunge 435L capacity	4.5 litres
Ice Plunge XL 500L capacity	5 litres

Step three After a 12 hour disinfection period, check the hydrogen peroxide level with a test strip to ensure that it is sitting around 500ppm hydrogen peroxide.

Step four You might find there's a little residual biofilm left on visible surfaces. This can be wiped clear using Huwa-San TR-3 on a clean cloth.

Step four Check the level of the hydrogen peroxide level in the after bathing. It should be between 300ppm and 500ppm hydrogen peroxide. If the level has dropped below 500ppm peroxide it should be topped up. Any residual biofilm left on visible surfaces can be wiped clear using Huwa-San TR-3 on a clean cloth.

WARNINGS:

As an industrial grade disinfectant the material should be handled safely.

Protective clothing is advised in case of splashes.

Rubber gloves are necessary (butyl rubber, natural rubber, polyethylene, viton and safety glasses as a minimum).

STORAGE:

KEEP SUBSTANCE AWAY FROM: heat sources and ignition sources.

Storage area:

Store in a cool area. Store in a dark area. Protect against frost.

In case of spillage:

Take up liquid spill into inert absorbent material such as sand and scoop the absorbed substance into closed containers.

Top up amounts:

Hydrogen Peroxide Level	Additional Huwa-San TR-5 Required
100 ppm	0.8 litres
200 ppm	0.6 litres
300 ppm	0.4 litres

Purchasing Huwa-San

Huwa-San can be purchased from Brass Monkey:

orders@brassmonkey.co.uk

0113 5267255

Alternatively you can purchase directly from the manufacturer:

www.safesol.co.uk

Full system flush

The ice bath can be periodically flushed using Huwa-San TR20 to remove build up of bio film and bacteria from the system. If you already use Huwa-San frequently then you will not need to run a system flush, however it is recommended to change the water and rinse the bath periodically.

Step 1	Switch the power off
Step 2	Drain half of the water and remove the filter from the filter housing.
Step 3	Fill the filter housing with Huwa-San TR20 to just below the top and replace the lid
Step 4	Pour 1 litre of Huwa-San TR20 into the filter housing and replace the lid
Step 5	Refill the water in the bath to just above the outlet
Step 6	Switch the bath on, set to 10°C and leave to run for 24 hours
Step 7	Drain the bath completely
Step 8	Using a hosepipe, rinse the bath and filter thoroughly
Step 9	Use a soft cloth to wipe clean the bath and the inside of the filter housing
Step 10	Refill with water and switch on again ready for normal use.

- The quickest way to drain the water is with a submersible pump connected to a hosepipe. Then drain the water away.
- See the previous page for details of where to buy Huwa-San
- Use gloves and goggles when handling Huwa-San TR20
- Full system flush recommended every 6 months



Going on holiday

If you are going away for more than a month we recommend the following action is taken:

Step 1	Switch the bath off by removing the plug from the socket.
Step 2	Empty all of the water from the bath.
Step 3	Remove the filter from the housing and leave the lid off.
Step 4	Clean the inside of the filter and the bath with a disinfectant spray. Use a wet vac if necessary to remove all water.
Step 5	Leave the insulated cover slightly off to allow air flow to the inside of the bath.
Step 6	Upon returning, follow the 'getting set up' instructions.

If you are likely to be leaving the bath for less than a month and would like to conserve energy, simply set the bath to 10 degrees and leave it. This will ensure minimum energy is used but the filtration still continues to be effective.

Operator responsibility and safety recommendations

Brass Monkey Health Ltd declines all liability for damages arising from failure to observe the following directions.

As the owner, it is your responsibility to:

- Ensure the safety of those using the bath and read and observe the health and safety warnings and safety recommendations as set out in this manual.
- Maintain the materials of which the bath is made by following the cleaning procedures in this manual.
- Use the bath according to the recommendations in this manual.
- Ensure a safe electrical connection to the bath; ice baths are 'class 1' appliances and must therefore be permanently connected, without intermediate junctions or extension cables, to the electrical network and to the protection circuit (earthing system) in your home.
- Ensure that the cabling does not present a slip hazard.

- Live electrical components and equipment (except those powered at a very low voltage not exceeding 12V) must be out of reach of individuals using the appliance.
- Parts containing electrical components must be positioned or fixed so that they cannot fall into the water.
- There will likely be times when water spills out of the bath, especially when getting in or out and we recommend taking a common sense approach and making sure there is good drainage for water on the floor around your bath and a non slip surface to step on to.
- **CAUTION:** Before carrying out any maintenance operations, disconnect the appliance from the power supply.
- **Do not** switch the power on to the bath until it is filled to the required level. Running the pump dry, without water, could cause immediate damage and void your warranty.
- **Avoid flooding!** We would advise that the level to which you fill your bath with water falls at least 20cm below the top to avoid flooding, ideally fill just above the water outlet from the pump (the highest hole to the rear). Top-up the water periodically as it lowers due to users entering/exiting to keep the water level high enough.
- Use your insulated cover. It is advisable not to leave the ice bath uncovered since ice melts in warm air, and requires the unit to be working more than it needs to.
- It is important to maintain water cleanliness in accordance with Brass Monkey Health's instructions by following the correct cleaning procedure set out on this manual, failure to do so can result in damage to the pump.
- **Do not** use chemicals such as ammonia, combustible substances, bromine, fluorine as this may damage the stainless steel and any residue left in the water may damage your health.
- Any repairs must be made by a Brass Monkey approved engineer. Brass Monkey cannot accept liability for any damage arising from alterations or repair made by non-approved engineers.
- It is the owners responsibility to ensure the power supply used for the bath is on an RCD protected circuit.
- For all operations and maintenance of the Ice Bath please refer to this manual and if in any doubt please contact Brass Monkey directly. We're happy to help!
support@brassmonkey.co.uk
0113 526 7255

Health and safety user recommendations

Brass Monkey Health Ltd declines all liability for damages arising for failure to observe the following directions.

- **Health disclaimer:** If you're unsure, please check with your doctor before using your Brass Monkey Ice Bath.
- Ice baths are suitable for the majority of people, the majority of the time, however it is best to take a cautious approach and we would advise that people with reduced mobility, sensory, and/or cognitive abilities only use the bath if supervised and only if they have the knowledge necessary to use the equipment safely, as well as to understand the dangers arising from improper use.
- Ice dipping is no walk in the park. Tolerance to cold water varies from person to person and we recommend being mindful of gradually building up the duration of use with the ice Bath or Ice Plunge and be cautious when using the ice bath alone.
- A note for the inexperienced. It is quite dangerous to suddenly jump into water that's significantly cooler than what you're used to as it can cause a shock to the body. Therefore, enter the water slowly and keep your face,

- shoulders and hands clear until your breathing is under control. The cold water shock response decreases with cold exposure experience and being mentally prepared.
- Start with safe, short dips of 30-60 seconds to learn what your limits are. If you begin to feel uncomfortable or you start to shiver, listen to your body, get out and slowly warm up by walking or taking slow air squats. Keep it fun!
- If you like, you can check the water temperature before entering the bath, to ensure that it is at temperature that is suitable for your experience in cold exposure. The temperature of the water is displayed as default on the control panel and is displayed in increments of 1°C, rounding down to the nearest whole number, and then drops in 0.1 increments below 1°C.
- Children must be supervised near the ice bath to make sure they do not play with the equipment and do not carry out operations to be performed by adults (cleaning cycles/maintenance). Always replace the cover when not in use.
- Small children are not advised to use the Ice Bath or Ice Plunge.

- Please check with your doctor as relevant.
- Pregnant women should talk to a doctor first, low temperatures are not advised.
- Anybody under medical care, such as people with heart conditions, diabetes, high or low blood pressure or other health problems must not use the ice bath without first consulting their doctor.
- People with infectious diseases should not use the ice bath without first consulting their doctor.
- **Do not** use the Ice Bath after drinking alcohol or taking recreational drugs. It must be stated that the use of alcohol or drugs can greatly increase the risk of fatal hypothermia in the ice baths.
- **Do not** use your Ice Bath during extreme weather conditions (during storms or floods etc). It is also recommended to place the bath in an area that will not attract standing water. Good drainage is essential so that the services compartment does not become submerged with water. If it does, switch the unit off and let everything dry out.
- Be very careful when getting in and out of the Ice Bath. Surfaces may be slippery when wet.

We are here for you

If you have any questions or require technical support
you can get in touch with us by the following means:

Email: support@brassmonkey.co.uk

Call us: 0113 526 7255

Raise a ticket in your online account

If you want to know more about getting your cold on, we have a guide on cold water immersion, the science behind it and how to build a cold water immersion practise.

This can be found in the app or downloaded
by scanning the QR code below.



BRASS  **MONKEY**[®]