

MULTITEL MX 196

Renault Maxity PTT=3500kg

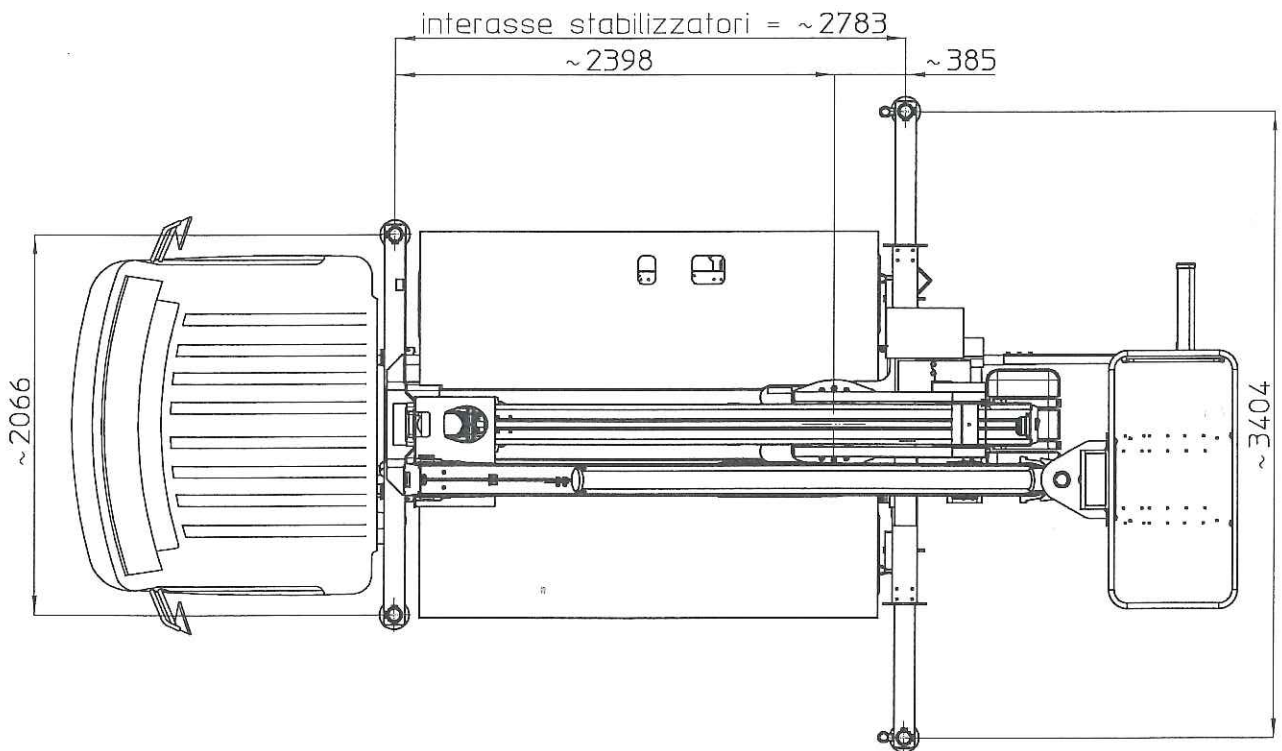
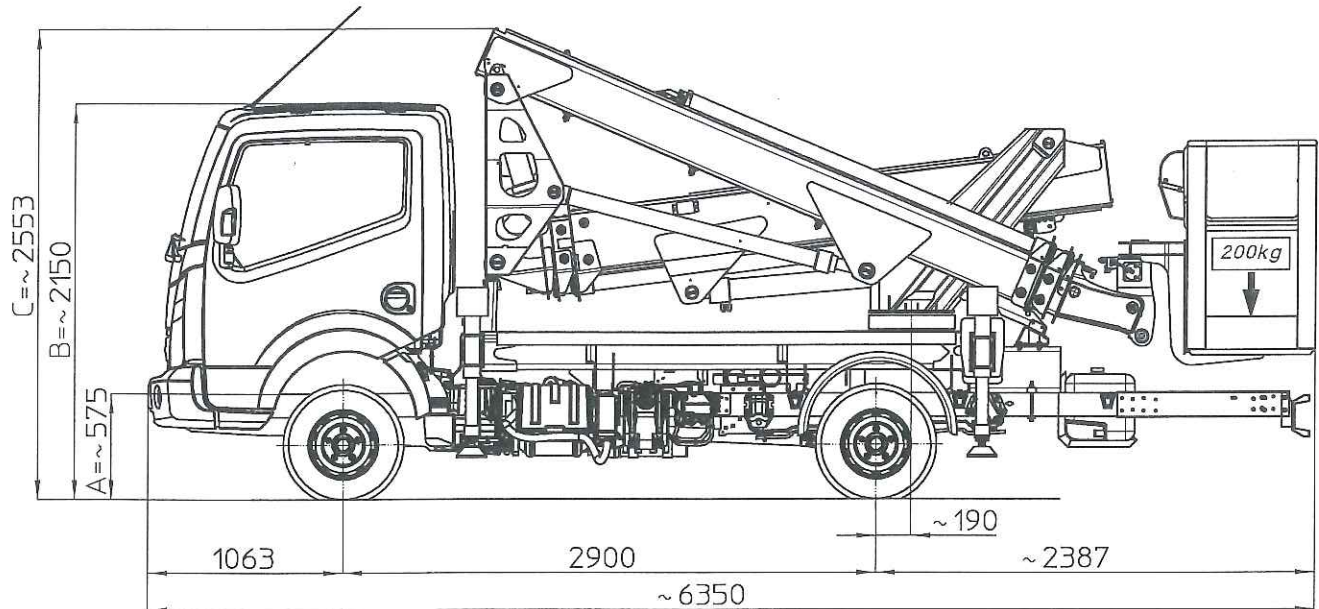

I - Le quote riportate in disegno sono indicative e possono subire variazioni. In particolare le quote A-B sono relative alle dimensioni dell'autocarro, quindi devono essere verificate sullo stesso. La quota C (altezza totale) e' subordinata alle quote A-B e non comprende eventuali parti flessibili.

F - Les cotes indiquée dans le dessin sont indicatives et peuvent subir des variations. En outre les cotes A-B sont relatives aux dimensions du porteur, donc elles doivent être vérifiées sur le porteur même. La cote C (hauteur totale) est subordonnée aux cotes A-B est indiquée hors flexibles.

E - The dimensions shown in the drawing are an indication and may undergo changes. Further the dimensions A-B are related to the truck sizes, therefore they must be verified. The dimension C (total height) is subject to A-B and does not include hoses.

D - Die Maße, die in der Zeichnung gezeigt werden, sind eine Anzeige und können Änderungen durchmachen. Die Abmessungen A-B betreffen die Fahrzeugmasse, daher sollten sie geprüft werden. Die Abmessung C (Gesamthöhe) hängt von A-B Abmessungen ab, die schlauche sind ausgeschlossen.

D62017

Ente	Rev.	Descrizione	Data	Dis.	Contr.	Ap.AQ
MRK	0	EMISSIONE	29/12/17	L.B.		

MULTITEL

MX196

Ente	Rev.	Descrizione	Data	Dis.	Contr.	Ap.AQ
MRK	0	EMISSIONE	29/01/16	L.B.		
DIAGRAMMA - SCHEDA 54/2 - Rev. 0 - 15/12/00						

D55733-M

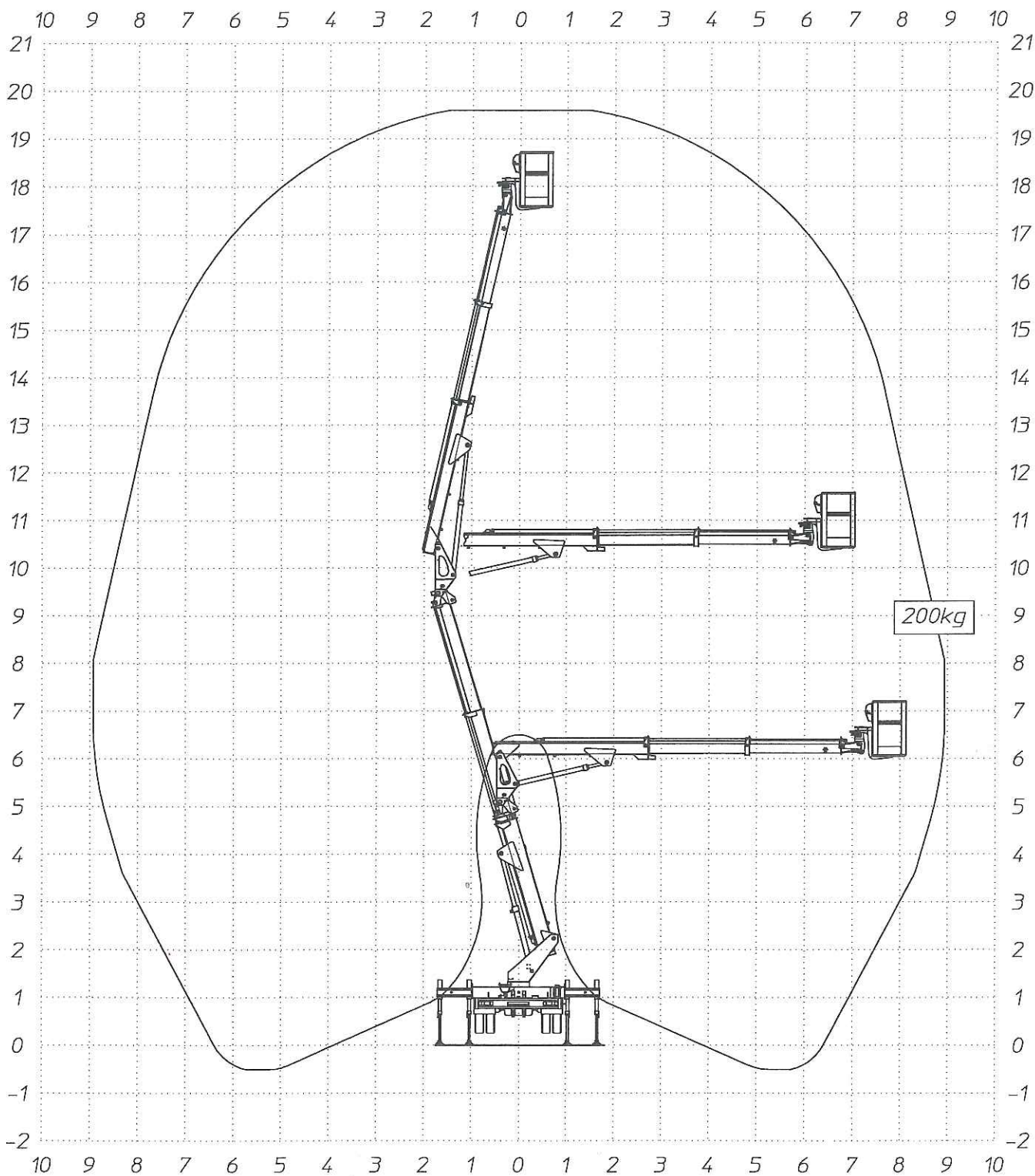

MULTITEL

MX196

Ente	Rev.	Descrizione	Data	Dis.	Contr.	Ap.AQ
MRK	0	EMISSIONE	29/01/16	L.B.		
DIAGRAMMA - SCHEDA 54/2 - Rev. 0 - 15/12/00						

D55732-M

