

Preplanning Guide



The First Steps to Creating the Perfect Bowling Center

Brunswick® 



The perfect center starts with the perfect partner.

With over 100 years of experience, knowledge, and service, Brunswick is the worldwide leader in the bowling industry. From superior bowling products, to planning, designing, and maintaining bowling facilities, Brunswick's expert service and technical support create the perfect partnership for building the perfect center.

Brunswick is behind the construction and re-imagining of many premiere bowling centers in the United States. Brunswick Build-To-Bowl™ construction group offers a comprehensive and unique array of services managed and directed by experienced and highly qualified industry professionals. This network of professional resources - planners, designers, architects, contractors, installers, and training professionals - provides a solid foundation, critical to completing your project on time and on budget.

There are many things to consider before construction of a bowling facility begins - even before the blueprints are drawn. From the selection of major equipment, down to the smallest details, Brunswick provides the support and direction needed to properly plan your center.

This bowling center Preplanning Guide provides a checklist of items for you to discuss with your architect and building contractor. It will help you anticipate your current and future needs, as well as create the most efficient design possible. Once you have taken the first steps detailed in this guide, you are ready to move on to Brunswick's Comprehensive Bowling Center Planning Guide.

Consider your location carefully.

Location

Locations containing restaurants, theaters, taverns, and other entertainment venues near residential areas are a good choice. Good visibility, easy access, and high traffic count all lend themselves to effective locations.

Zoning

Zoning can be a deciding factor in your bowling center location. Consider building expansion and additional services as well. Be aware of any ordinances that could affect your future plans.

Property Size

Your desired center size (lane quantity) and supporting services will dictate the size of your property.

Maintenance

Ease of maintenance contributes greatly to your bottom line and your overall appearance of quality. Consider all materials based on their life-span and required care.

Since reliable equipment is the key to happy bowlers, it is essential to provide proper, effective Brunswick pinsetter and lane maintenance training for your maintenance team.

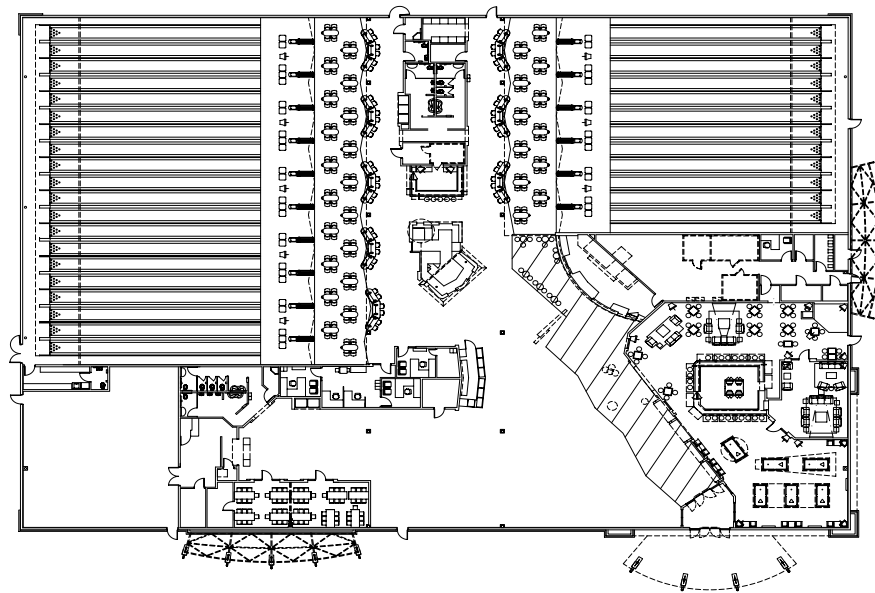

Brunswick Build-To-Bowl project

Parking Requirements

Check your local government guidelines for the required number of parking spaces based on the size of your center. Parking will also be governed by the number of entertainment venues included in your project. Be certain to provide enough space for additional paving if you wish to expand the center size in the future. These areas could be used as green space or children's outdoor play areas until needed.

Visibility

This is your best advertising. Consider locations with high traffic volume and as few competing structures as possible.

Signage

The design of your signage is very important. It is a big part of your brand identity and should make a statement. Remember, changing it in the future is expensive and could affect your visibility as well as your identity.

Lighted signage and electronic reader boards, if permitted by local codes, are recommended. They attract attention and can be seen from a greater distance.

Proper exterior lighting can make a strong inviting statement about your center and provides night-time security for your patrons.

Existing Building

There may be existing structures that can be adapted to the needs of a bowling facility. Just be sure to consider the costs of bringing an existing building up to local regulations and compare those costs to new construction. For example, an existing building may require the following renovations: 2nd floor facility elevator, handicap access, proper water pressure, proper sprinkler system, electrical power accommodating the building size, roof inspection for leaks and wear, HVAC operation, sufficient ceiling height, and sufficient spacing for lanes between post rows.

When designing a new building, the structure should have a clear span in the bowling equipment area and a ceiling height of at least 10' (3.05 m). Bowling centers require specific heating, cooling, humidity, and electrical control systems. Discuss these requirements and their costs with the proper professionals before making your decision on an existing facility.

Building Size

To help you determine the size of the building, use the "Bowling Lane Widths" chart and decide what other services, entertainment, and amenities you would like to provide. The width of the building is determined by adding the thickness of outside walls, the width of side aisles, and the required space for columns, if any, to the width of the uninterrupted bowling lane bays.

Lane Length

The basic installation length is determined by using a recommended 5' (1.52 m) aisleway behind GS-X™ Pinsetters (4' or 1.22 m minimum), plus the 83'4 1/2" (25.41 m) length of the bowling lane which includes the pinsetter, lane, and approach. A bowlers' concourse area of 30' (9.14 m) is preferred with a minimum 12' or 3.66 m (preferable 22' or 6.71 m) for the actual bowlers' seating area.

Bowling Lane Widths

The following dimensions are net measurements of uninterrupted lane widths only. Additions should be made for columns, walls, and passages between or beside lanes.

Number Of Uninterrupted Lanes	Minimum Width	10 1/2" Returns
2	11' 6"	(3.51 m)
4	22' 7 1/4"	(6.89 m)
6	33' 8 1/2"	(10.27 m)
8	44' 9 3/4"	(13.66 m)
10	55' 11"	(17.04 m)
12	67' 1/4"	(20.43 m)
14	78' 1 1/2"	(23.81 m)
16	89' 2 3/4"	(27.20 m)
18	100' 4"	(30.58 m)
20	111' 5 1/4"	(33.97 m)
22	122' 6 1/2"	(37.35 m)
24	133' 7 3/4"	(40.74 m)
26	144' 9"	(44.12 m)
28	155' 10 1/4"	(47.50 m)
30	166' 11 1/2"	(50.89 m)
32	178' 3/4"	(54.27 m)
34	189' 2"	(57.66 m)
36	200' 3 1/4"	(61.04 m)
38	211' 4 1/2"	(64.43 m)
40	222' 5 3/4"	(67.81 m)
42	233' 7"	(71.20 m)
44	244' 8 1/4"	(74.58 m)
46	255' 9 1/2"	(77.96 m)
48	266' 10 3/4"	(81.35 m)

For each additional pair of lanes add 11' 1 1/4" (3.38 m).

Furniture

Depending on the type of center environment you wish to create, there are numerous furniture styles and layouts to consider. The Brunswick Collection includes the Striking Line™, featuring stylish and comfortable living-room furniture and the Frameworkx® Line, which includes customer-friendly table-top seating. Both furniture collections support any configuration and space requirements you may have.

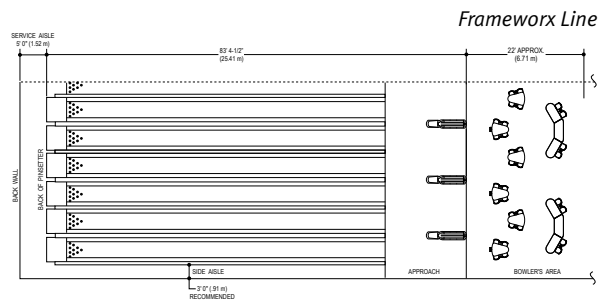
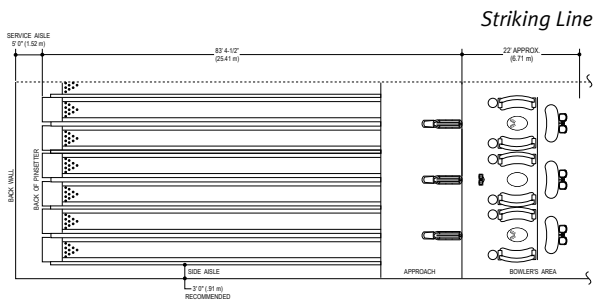



Bowling Business Models

In recent years the bowling industry has experienced a bit of a renaissance. Trends for new center development have moved away from traditional bowling centers toward a variety of new center concepts focused on the total entertainment experience. These new center concepts include Family Entertainment Centers, Boutique Bowling Centers and Hybrid Centers. A knowledgeable Brunswick representative will help you identify the type of center that is most appropriate for your market.

Traditional bowling centers are primarily focused on bowling and include a limited number of entertainment venues, typically featuring a game room and billiards area, pro shop and bar. Beverages play a strong role at traditional bowling centers and the food is usually limited to snack bar offerings.

Family Entertainment Centers (FECs) are designed to provide entertainment in the form of bowling and various other venues. These venues may include arcades, laser tag, go karts, bumper cars and party rooms in addition to the venues found at traditional bowling centers. The food offering at FECs is enhanced to match the atmosphere and beverage service plays a strong role. Typical options include snack bar, food court and branded concepts.

Boutique centers are focused primarily on entertainment and socialization with full service, upscale food and beverage offerings. Bowling is the primary form of entertainment, but is a smaller component of the business and is set in a contemporary, social atmosphere. Boutique centers offer ancillary entertainment options such as live music, billiards, virtual/cyber gaming, and bocce as additional sources of revenue.

Hybrid centers are designed using the FEC and Boutique bowling center concepts in the same venue, with a combined focus on bowling, games, a multitude of entertainment venues, and upscale food and beverage offerings. An ultra-modern VIP bowling area is typically available for groups and private parties in Hybrid centers.

Profit Opportunities

Create more diverse profit opportunities with the name that built the game. Brunswick has played an integral role in making the bowling industry what it is today: the world's leading recreational sport – with revenues now reaching well over \$10 billion a year and drawing over 100 million participants worldwide. Brunswick and its consultants have continued to grow new center profitability by developing complementary opportunities through additional entertainment activities and customer conveniences including:

- Billiards and Coin-Operated Games
- Virtual Bowling, Virtual Amusement and Laser Tag
- Children's Activity Centers
- Theaters and Party Rooms
- Internet Café, Juice Bar, Restaurant or Snack Bar
- Lounge/Bar/Nightclub/Disco
- Table Tennis and Volleyball
- Mini-Golf, Go-Karts (Indoor/Outdoor), and Bumper Cars
- Extreme Skate Park
- Rock Climbing Wall
- Indoor/Outdoor Waterparks
- Pro Shops
- Party and Multi-purpose Rooms
- Locker Rooms
- Vending

Building Construction

Bowling Lane Foundations

Planning your bowling center starts from the ground up with a strong foundation. The I-joint foundation is a precisely engineered product that will provide the most stable and rigid foundation. The result is a foundation that will keep the lane flatter longer, which over time will save maintenance expense and provide the bowler with more consistent lane conditions.

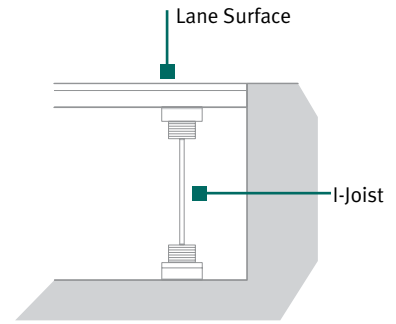

Concrete Floor

- Floors are usually poured in strips rather than in one pour. Be sure to “key” the concrete to ensure the waterproof quality and avoid “heaving”.
- The need for, type, and location of expansion joints must be determined by the architect.
- Concrete in the bowlers’ seating area should be thick enough to accept a 4” (10.16 cm) anchor for seating and other related equipment.
- Bowling lanes are installed on a waterproof, reinforced concrete slab poured over compacted fill. In the lane area, the surface must be power-troweled and level. A close tolerance of 1/2” (1.27 cm) will avoid excessive shimming of lane foundations.

Drying Time

- It is the customer’s responsibility to provide concrete conditions conducive to installation. Concrete drying time and pH levels can vary. Consult your architect and concrete contractor to ensure concrete is completely dry and pH levels are within the desired range.

Hardening and Dust-Proofing

- The GS-X Pinsetter area and service aisles should be power troweled, hardened, and dust-proofed concrete. Concrete not covered with tile or floor covering should be permanently sealed.

Second Floor Installation

- If lanes are to be installed on the second floor or higher, you must provide a floor strong enough to carry the load of the bowling equipment and public occupancy.
- Consider the noise in the spaces below and adjacent to the lanes. Soundproofing may be required.
- Your floor must be constructed to limit vibration. Your architect or engineer must certify the floor on the Brunswick floor-loading certificate.

Ceiling

- Ceiling structure and material should be chosen carefully.
- The ceiling height may be 10’ (3.05 m) to 12’ (3.66 m) above the lane surface. A 12’ (3.66 m) ceiling is recommended.

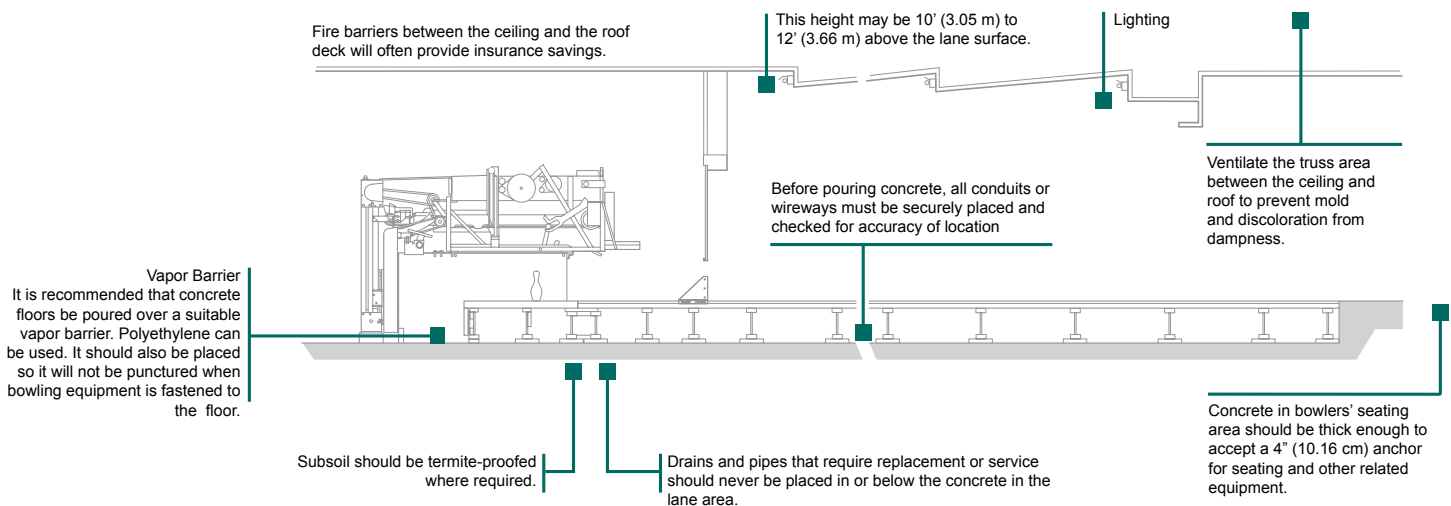

Structural Requirements

- Regardless of the type of ceiling material selected, provisions must be made for supporting Brunswick overhead scoring equipment.
- A Brunswick Overhead Support Certificate must be signed by the architect or engineer.

Clear Span Ceiling

- A clear span is the ideal type of ceiling for bowling installations. Plan to run trusses the full length of the lanes rather than the width. This allows for easier future expansion while still providing a clear span. A catwalk should be installed over the lanes to facilitate maintenance of ceiling, roof, and electrical wiring.
- Restroom and storage area ceilings should be “fixed” rather than suspended.

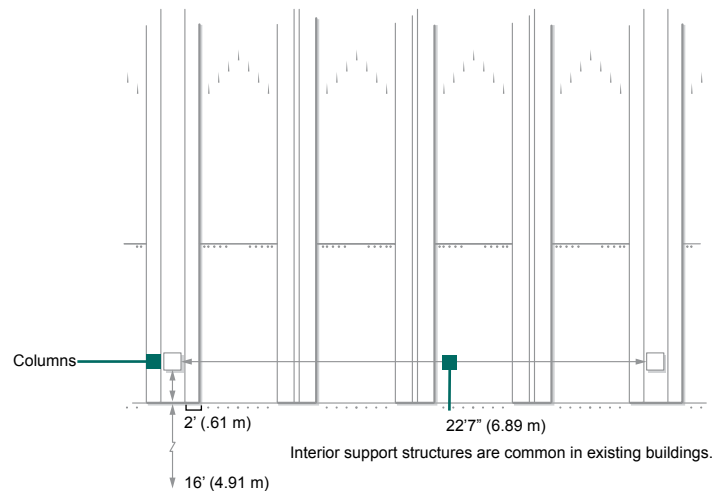

Columns in the Lane or Bowlers' Area

- Where supports for the structure above the lane are necessary, it is desirable to use a minimum lateral spacing between columns of 22' 7" (6.89 m) per four lane bay plus 1" (2.54 cm) for clearance to reduce noise transmission.
- The 16' (4.91 m) approach area and at least 2' (0.61 m) beyond the foul line should be kept free of columns, if possible.

Energy Management and Lighting

Energy Management

Efficient heating, air conditioning and environment control are paramount to establishing a comfortable setting for the customers and employees of this entertainment center. This must also be considered for the proper operation and longevity of the bowling equipment as well as overall maintenance of the center. Items such as airflow, filtration, and stable relative humidity of 45% along with a consistent temperature of 72° fahrenheit (22.2° celsius), are important factors that an architect must consider when designing a project.

An automated management system for controlling the center's total environment is recommended. This will allow you to achieve a comfortable center as well as help control operating costs.

Lighting

It is important to provide proper lighting to create the desired environment for your customers. Take into consideration the type of event you are hosting and the specific venue. During the course of league or competitive bowling, the lane area should be well lit. The lighting system should be flexible in order to change the mood of the center with black lights and Cosmic Bowling® lighting for entertainment, parties, and casual bowling events. Consider specific lighting applications for each area of your center, including your front entry way, front desk, bar, restaurant, meeting rooms, game rooms, etc. It is recommended that the architect work with Brunswick consultants that are familiar with both bowling and entertainment venues.





Building Layout

- Side aisles should be reserved for access to pinsetters and service areas. It is recommended that only authorized, trained personnel are allowed in the pinsetter working area. Provide a locked aisle way door leading to the pinsetters. The width of side aisles is determined by the width of the building. A side aisle width of 3' (0.91 m) is suggested. If no side aisle is provided, at least 1' (30.5 cm) should be allowed from the outside edge of the gutter to the wall giving bowlers freedom of movement on the approach.
- Take care when planning for traffic patterns now and in the future. Consider how patrons will access the control counter, spectator areas, and food and beverage service.
- Facility planning can affect the efficiency and quality of housekeeping and other operational needs. Make sure your plan takes all general facility service requirements into account.
- If offering a full service dining and cocktail lounge, it is recommended that you provide a separate entrance in addition to the bowling center entrance.

Interior Design

- It is important that you consult with your architect and interior designer to ensure an entertaining, functional center.
- Carpet is recommended in the concourse to trap dirt that otherwise might be carried onto the bowlers' area where it could damage approaches and lane surfaces.
- Choose materials that are durable and easy to maintain, in colors that will not be quickly outdated. Static-free materials are recommended.
- Discuss acoustics with your architect. The satisfying crash of the pins when a bowler makes a strike should not be eliminated, but care must be taken to ensure that the sound of the pins does not become overwhelming. If patrons cannot socialize, they will not return.

Take the next step toward a successful bowling center. Contact your Brunswick representative for a Comprehensive Bowling Center Planning Guide with AutoCAD images.

For additional planning, product, and support services information regarding your new center development, visit our website at www.brunswickbowling.com/newcenter_home.

Brunswick is committed to continuous improvement. As a result, all specifications are subject to change.
Not for reproduction without the expressed written consent of Brunswick Bowling & Billiards Corporation. ©2008 Brunswick Bowling & Billiards Corporation. Printed in USA. #0208-18

Brunswick[®]
www.brunswickbowling.com

Americas: Brunswick Bowling & Billiards • 525 West Laketon Avenue • Muskegon, MI 49441-2697 USA • Tel: 1.800.YES.BOWL • 231.725.4966

Europe: Brunswick GMBH • Ginnheimer Str. 6 • D-65760 Eschborn • Germany • Tel: 0049.6196.47.27.13

Asia Pacific: Brunswick Bowling & Billiards • Miramar Tower Room 2610 • 132 Nathan Road Tsimshatsui • Hong Kong, China • Tel: 852.2367.8080