

Description: **ROBINHOOD SLIDEOUT**

Model Number: **RLES6SS, RLES6WH, RLES9SS, RLES9WH, RLES61SS/WH, RLES91SS/WH**

Typical design

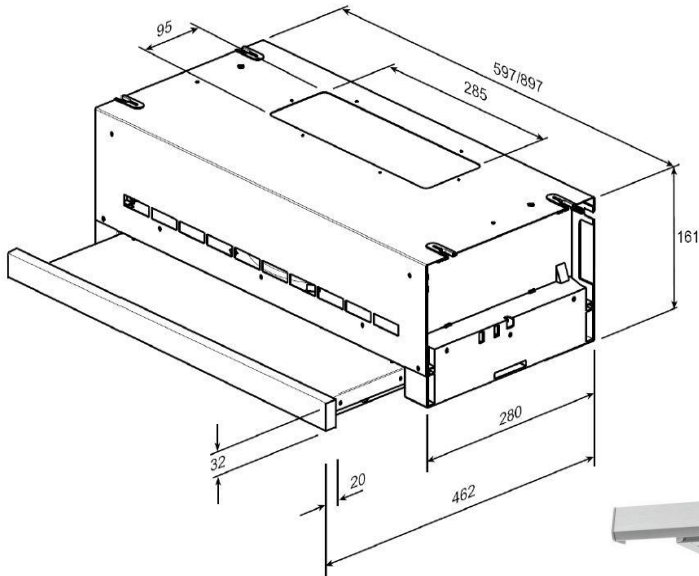

Features and benefits

- **High performance extraction fan**

High performance extraction fan rapidly removes steam, smoke and cooking smells from your kitchen. Three-speed switch lets you select the fan strength you need – half strength for steamed vegetables; full strength for stir fries.

- **Halogen lamps**

50 watt halogen lamps illuminate the entire cooking surface. Lamps are quick and easy to replace.

- **Multi-layered micromesh filters**

Multi-layered micromesh filters effectively trap grease. They're simple to remove and are easily maintained with a regular clean in the dishwasher.

- **Rectilinear design**

Simple styling makes cleaning easy. High quality stainless steel or powder coated steel and the fingertip controls are easy to clean with a damp cloth.

- **Thermal overload switch**

Thermal overload function that senses extreme heat and disconnects power to the motor temporarily. If you have a cooking disaster, and something catches fire, the rangehood automatically switches off to prevent flames and sparks being sucked into the ducting or ceiling.

Specifications

Technical data:

- 3 speed axial motor
- 2 x 50 Watt halogen lamps
- Gauge of steel: 0.6 mm
- Type of steel: panel steel
- Finish of steel (RLES6SS, RLES9SS): powder coated matt black body, stainless steel handle
- Finish of steel (RLES6WH, RLES9WH): powder coated appliance white
- 230-240 Volt. 50 Hertz. 165 Watt Max.
- Tested to EMC AS/NZS4417
- Electrical approval: AS3310-1992
- Performance tested to IEC61591
- Filter specifications: three layered micro mesh
- Length of power cord: 1200mm
- Ducting outlet: 285 x 95mm top or rear

Gross weight: 6.3kg (600 model), 8.5kg (900 model)

Carton volume: 0.044m³ (600 model), 0.064m³ (900 model)

Carton dimensions : 340 x 200 x 640mm (600 model), 340 x 200 x 935mm (900 model)

Rangehood dimensions: 280 x 161 x 597mm (600 model), 280 x 161 x 897mm (900 model)

Performance data:

Gross	409m ³ /hr
Nett Fan speed 1	223m ³ /hr
Nett Fan speed 2	288m ³ /hr
Nett Fan speed 3	351m ³ /hr
Noise speed 1	53dB
Noise speed 2	61dB
Noise speed 3	62dB

Australia

Shriro Australia Pty Limited
(ABN 28 002 386 129)
Telephone: 1800 648 556
Facsimile: 1800 628 577
Email: enquiries@robinhood.com.au
www.robinhood.com.au

New Zealand

Monaco Corporation Ltd
Telephone: (09) 415 6000
Facsimile: (09) 415 7400
Email: enquiries@robinhood.co.nz
www.robinhood.co.nz