

LISTE DES PIÈCES DÉTACHÉES / LIST OF THE CHAIR PARTS / LISTA DE LAS PIEZAS DE LA SILLA

FR : (Note : Certaines parties peuvent être différentes de l'image mais les réglages sont identiques.)
 EN : (Note : some parts can be different from the picture, but adjustments remain similar)
 ES : (Nota : Algunas partes pueden ser diferentes de las imágenes pero los ajustes son idénticos).

1) Vérin pneumatique
Gas Lift
Cilindro de aire



5) Type B – vis noires
Type B back screws
Tipo B - tornillos negros



9) Vis
Screws
Tornillo



2) Base



6) Vis accoudoirs
Armrest screws
Tornillos de reposabrazos



10) Appui-tête
Headrest
Reposacabezas



3) Roues x 5
Castor x 5
Ruedas x 5



7) Clé Allen
Allen Wrench
Llave Allen



4) Assise
Seat mechanism
Asiento

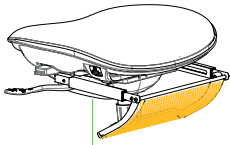

8) Accoudoirs
Armrests
Reposabrazos



11) Dossier
Assembled back
Respaldo

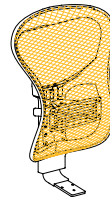

ÉTAPE 1 / STEP 1 / PASO 1

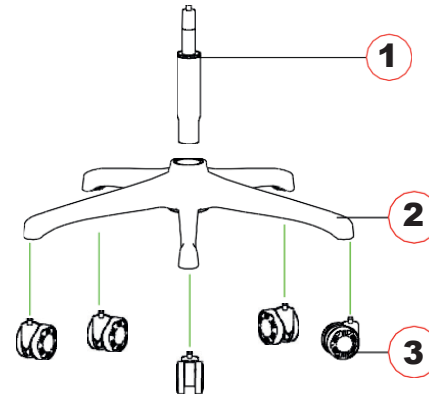

ÉTAPE 2 / STEP 2 / PASO 2

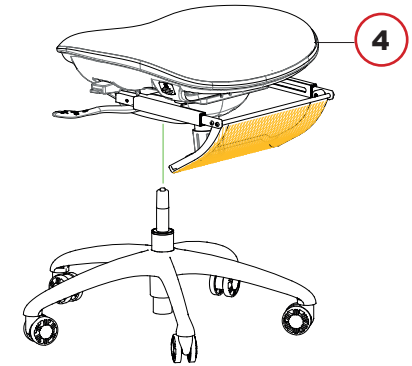

ÉTAPE 3 / STEP 3 / PASO 3

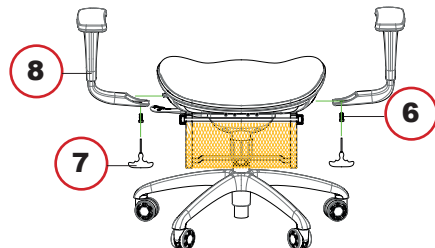

ÉTAPE 4 / STEP 4 / PASO 4

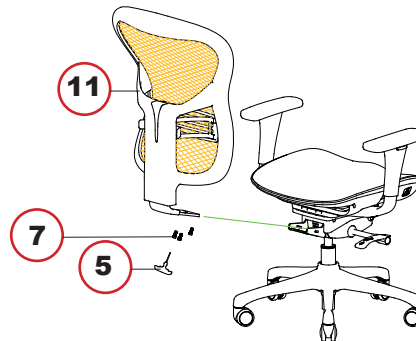

ÉTAPE 5 / STEP 5 / PASO 5

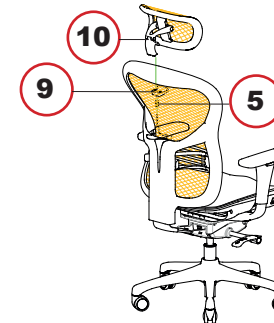

- 1) Réglage de la hauteur et inclinaison de l'appui-tête**
Height and tilt angle of headrest adjustment
Ajuste de la altura e inclinación del reposacabezas

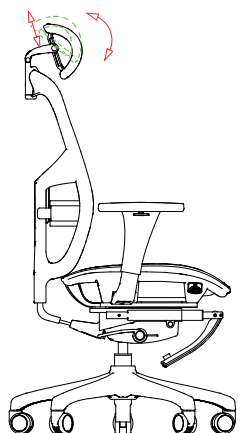

- 2) Réglage du support de l'appui-tête**
Headrest holder adjustment
Ajuste del soporte del reposacabezas

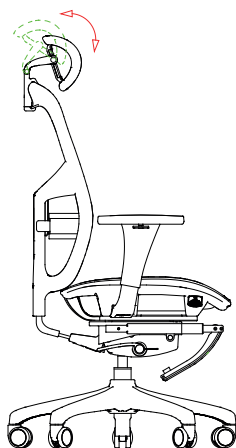

- 3) Réglage des accoudoirs**
Armrest adjustment
Ajuste del reposabrazos

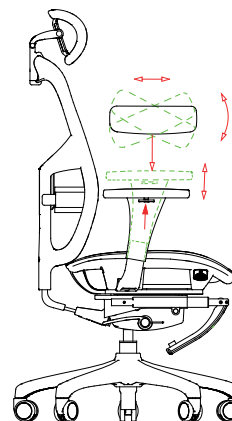

- 4) Réglage de la hauteur du dossier**
Height of backrest adjustment
Ajuste de la altura del respaldo

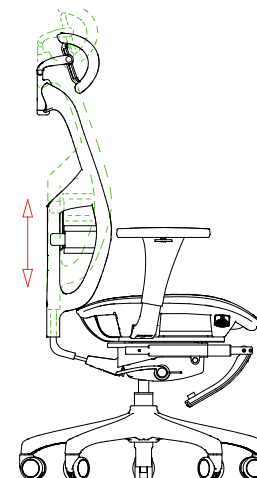

- 5) Réglage de la profondeur siège**
Seat depth adjustment
Ajuste de la profundidad del asiento

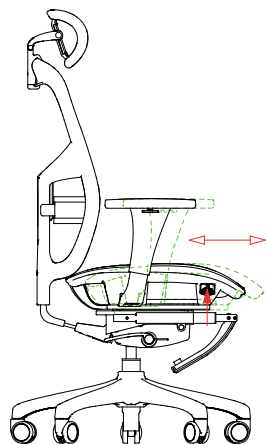

- 6) Réglage du support lombaire**
Height of lumbar adjustment
Ajuste del soporte lumbar

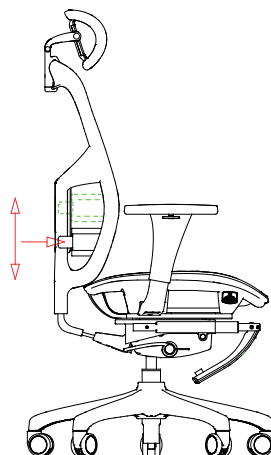

- 7) Réglage de la hauteur du siège**
Height of seat adjustment
Ajuste de la altura del asiento

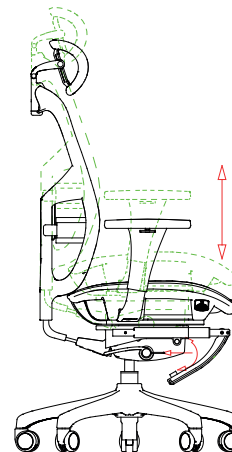

- 8) Réglage de l'amplitude du retour**
Radian of tilting adjustment
Ajuste de la amplitud de la inclinación

