

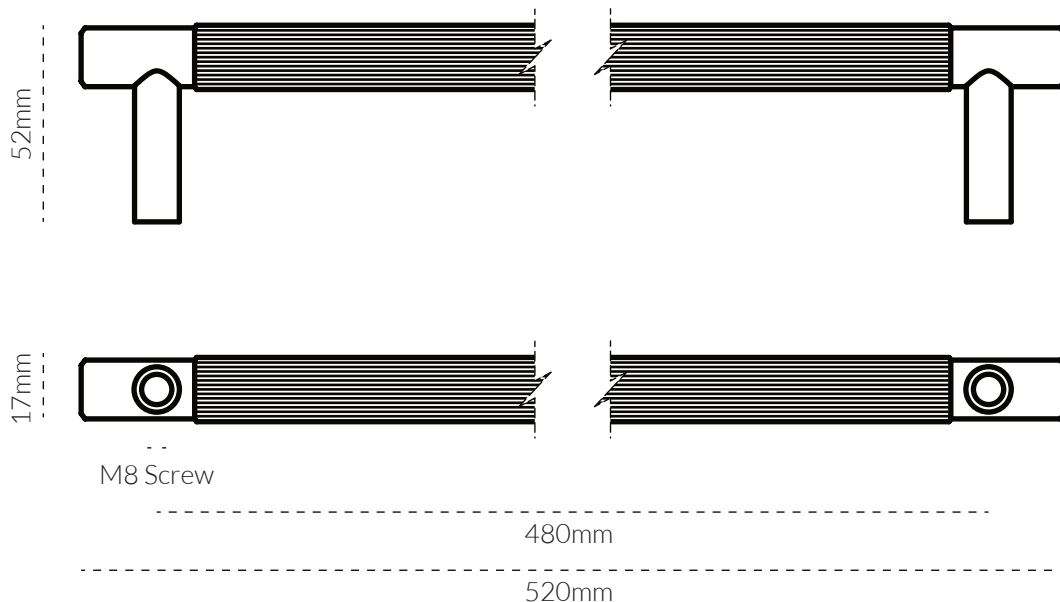







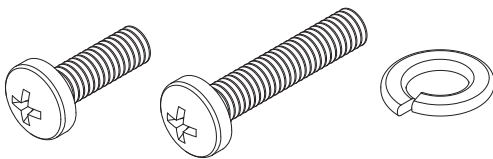

LINEAR APPLIANCE PULL 520MM

TECH SPEC

SPECIFICATIONS



| FINISH | SKU | FIXINGS ALSO INCLUDED |
|--|---------------|--|
|  Natural Brass | 4075-520-US4 | <ul style="list-style-type: none"> - 2x M8 * 25mm Screw - 2x M8 * 40mm Screw - 2x M8 Spring Washer  |
|  Aged Brass | 4075-520-AB | |
|  Bronze | 4075-520-BR | |
|  Brushed Nickel | 4075-520-BN | |
|  Matte Black | 4075-520-US19 | |
|  Matte White | 4075-520-W | |

CARE INSTRUCTIONS

Wipe with damp cloth and avoid using any chemicals.