



WWW.DEKRA-LITE.COM 1.800.436.3627
3102 West Alton Avenue Santa Ana, Ca 92704

RGB LEGACY SEQUOIA TREE

INSTALLATION INSTRUCTIONS

SEQUOIA TREES: INSTALLATION PREPARATION

SITE PREPARATION

Install the tree on a dry, flat level surface. Conduct ground markings as necessary to make sure the location for the tree installation is correct. The diameter of the tree is equal to roughly half the height, please see the chart below.

PROPERLY SECURING THE TREE

It is up to the installers to determine how to properly secure the tree to withstand local weather conditions and/or environmental elements. Separate instructions are available for using guy wires, and water barrels to secure a tree.

CHECKING THE POWER SOURCE

Check with an electrician before connecting the tree to a power source. It is important to ensure there is ample power. Check the chart below to calculate power usage.

UNPACKING AND IDENTIFYING ALL PARTS

Unpack all tree frames with care. If pressure is applied, bending or warping may occur. If you are unwrapping the frames with a cutter or sharp object, be careful not to cut the electrical wires of the runline and the lead cable pre-attached on some frames. Refer to the **PARTS LIST** for parts identification.

TOOLS REQUIRED

- Cutter
- Pliers
- Ratchet Wrench (with 5/8" size sockets)

SEQUOIA TREES: ASSEMBLY CHART FOR SIZE & PARTS

	LEVEL	TREE HEIGHT IN FEET	BRANCHES PER ROW	TOTAL NUMBER OF BRANCHES INCLUDING RED TIP BRANCHES	METAL BOTTOM RING OD INCHES	OD TREE IN INCHES	TOTAL WATTS (ESTIMATED 9.6W PER STRAND)	TOTAL AMPS	TOTAL WEIGHT IN LBS.	TOTAL U CLAMPS REQUIRED	TOTAL U CLAMPS REQUIRED SMALL SIZE 4.25" LONG	TOTAL U CLAMPS REQUIRED MEDIUM SIZE 5.5" LONG
	Tree Top	5	0			52	57.6	0.5				
Number of Metal Frames	Pole	8	6	6		56	115.2	1				
		10	6	12		60	172.8	1.4				
1	A		6	18	20	72	230.4	1.9	267			
1	B	14	8	26	30	80	307.2	2.6	395	3	3	
1	C	16	8	34	40	90	384	3.2	516	6	6	
2	D	18	12	46	50	100	499.2	4.2	664	16	16	
2	E	20	14	60	60	110	633.6	5.3	844	26	26	
2	F	22	18	78	70	120	806.4	6.7	1043	36	36	
2	G	24	20	98	80	130	998.4	8.3	1303	46	46	
4	H	26	24	122	90	140	1228.8	10.2	1596	66	66	
4	I	28	28	150	100	150	1497.6	12.5	1896	86	86	
4	J	30	28	178	110	160	1766.4	14.7	2229	106	106	
4	K	32	32	210	120	170	2073.6	17.3	2595	126	126	
4	L	34	36	246	130	180	2419.2	20.2	3012	146	146	
4	M	36	40	286	140	190	2803.2	23.4	3556	166	166	
6	N	38	42	328	150	200	3206.4	26.7	4191	196		30
6	O	40	42	370	160	210	3609.6	30.1	4795	226		60

SEQUOIA TREES: PARTS LIST



FRAME(S)

A letter is marked on the frame for identification of different rows. Refer to the "Sequoia Tree: Assembly Chart for Size and Parts" for the exact frame and pole counts for your tree size.



HARNESS ATTACHED ON FRAMES

For power connection of light strings.



U-CLAMPS & BOLTS

For assembling the frame together. Refer to the "Sequoia Tree: Assembly Chart for Size and Parts" for the exact sizes and quantities of u-clamps needed for your size tree.



1 TREE TOP

5 feet in height for installing on top of the Topper Pole.

6 RED TIP BRANCHES

Red color marked for inserting into the sleeves of the Topper Pole.

1 POLE
CONSISTING
OF AN UPPER
AND LOWER
SECTION



TOPPER POLE UPPER SECTION

3 feet in height with red-color marking the branch sleeves for installation of the Red Tip Branches.

TOPPER POLE LOWER SECTION

2 feet in height for installation of Standard Branches.

**THESE
ITEMS
SHIP
ALL IN
1 BOX**



STANDARD BRANCH

For inserting into the sleeves of the Topper Pole Lower Section and different rows. Refer to the "Sequoia Tree: Assembly Chart for Size and Parts" for the exact number of branches for your size tree.



ELECTRICAL HARNESS

For connecting the runline to the ground.

SEQUOIA TREES: ASSEMBLY DIAGRAM

BEFORE YOU BEGIN, SORT THE TREE FRAME SECTIONS BY LETTER AND MAKE SURE ALL TOOLS AND PARTS ARE ACCOUNTED FOR AND ACCESSIBLE.



FRAME(S)

A letter is marked on the frame for identification of different rows. Refer to the "Sequoia Tree: Assembly Chart for Size and Parts" on page 2 for the exact frame and pole counts for your tree size.

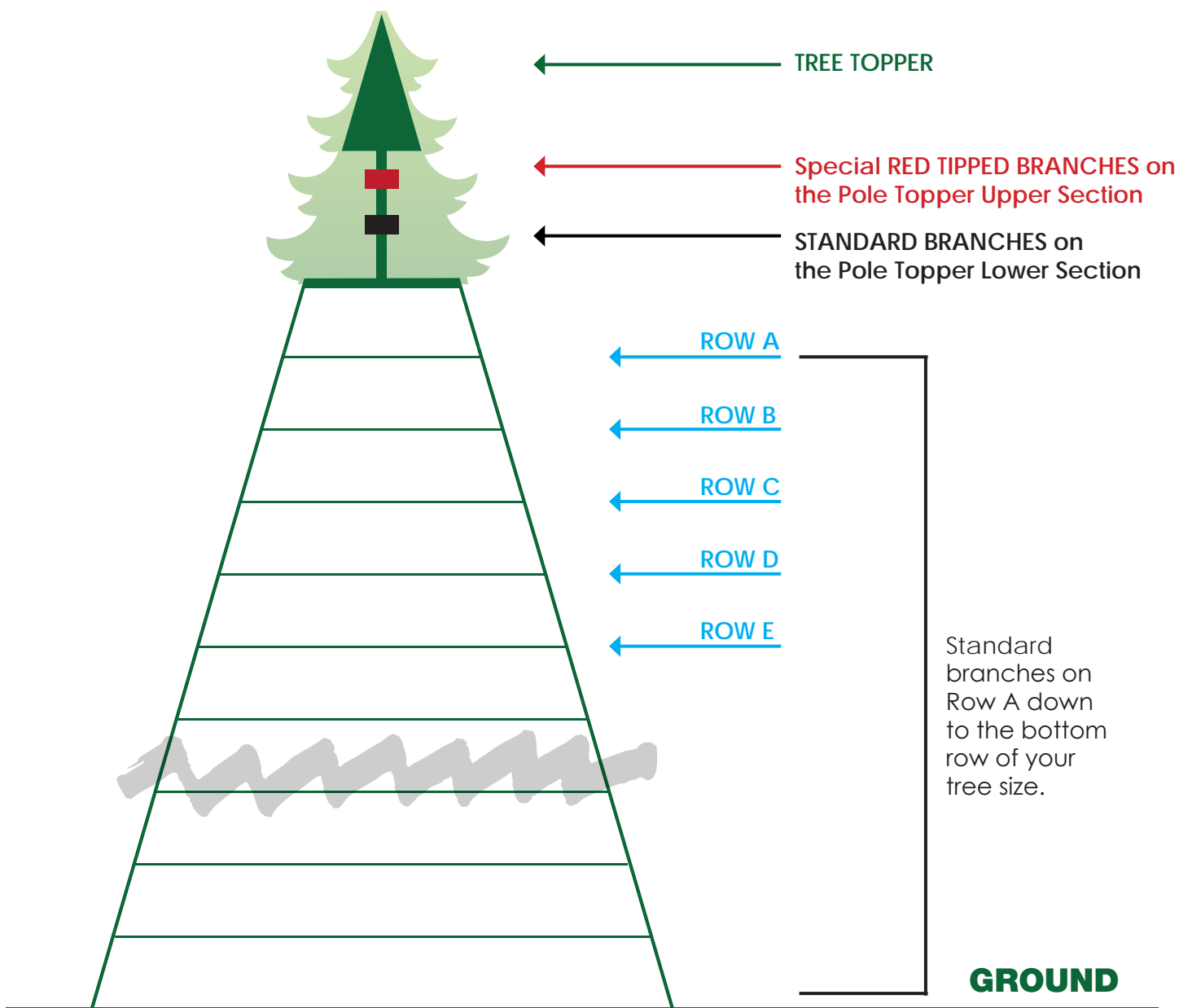

SEQUOIA TREES: FRAME INSTALLATION

STEP 1 FRAME INSTALLATION

Starting with the bottom row (highest letter) match the letter marked pieces (e.g. "F" to "F", "E" to "E", "D" to "D") and connect the frame pieces together using the U-Clamps provided. **Do not tighten the U-Clamps until you have placed all the U-Clamps for that row.**



STEP 2 ELECTRICAL ASSEMBLY

Stack the frames up row by row up to Row A. Stack the rows vertically level by level. For each stacked row, verify that the main column is aligned vertically, so that the power runlines between the rows can be connected.

stacked frames

electrical runline

actual runline

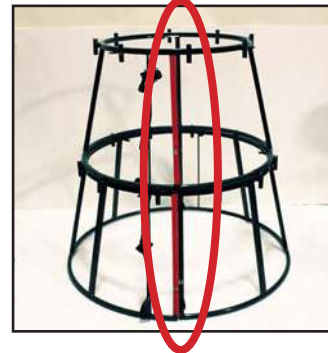
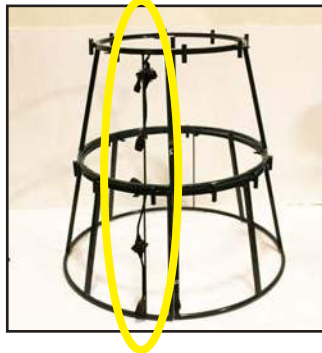
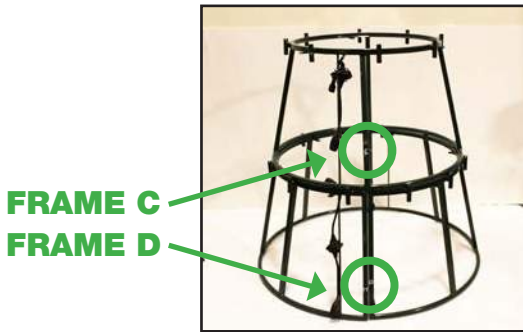

**** SPECIAL INSTRUCTIONS ****

FOR TREES TALLER THAN 26 FEET (ROW H AND ABOVE)

In addition to the letter coding system, trees with a height of 26' and above also have a numbering system labeled on frame sections 'H' and above. Align the numbers vertically as you stack the frame sections to ensure that the power runlines are correctly positioned. There is an example below showing Row H.



SEQUOIA TREES: FRAME INSTALLATION

STEP 3 SECURING THE FRAME

Secure the stacked rows together vertically with the provided U-clamps. Do not tighten the U-Clamps until you have placed all the U-Clamps for that row.



STEP 4 TOPPER INSTALLATION

After the top row (Row A) has been securely installed and the runline connected, slot in the Topper Pole on top of Row A. Align and connect the runline of the Topper Pole with the runline of Row A. Secure the Topper Pole on top of Row A by tightening the 6 units of M10 push bolts one by one.



STEP 5 LEAD CABLE CONNECTION

Plug the lead cable(s) to power supply (maximum 110V / 15A single phase per lead cable)

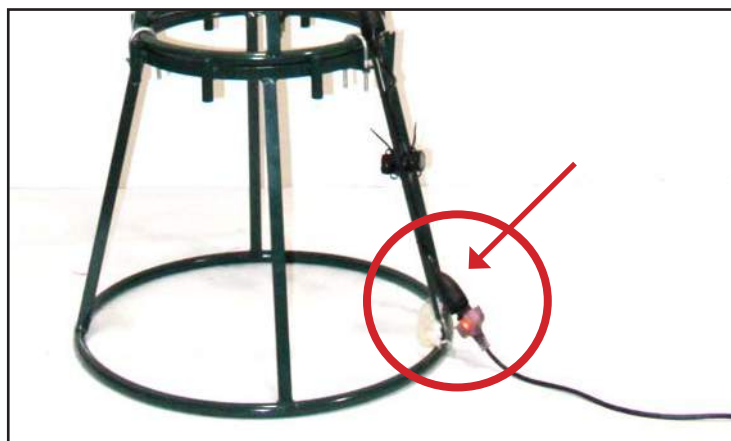



www.dekra-lite.com • 1.800.436.3627
3102 West Alton Avenue Santa Ana, Ca 92704

RGB LIGHTS ON YOUR SEQUOIA TREE

INSTALLATION INSTRUCTIONS



SEQUOIA TREES: RGB ASSEMBLY CHART FOR SIZE & PARTS

NOTE: The installation of an RGB SEQUOIA TREE will have to be done very carefully. RGB lights are run by a computer generated animation. The cables feeding the power also provide data. All electronic and data parts should be handled with care. Avoid hard bends and kinks on all light strands and data cables.

	LEVEL	TREE HEIGHT IN FEET	BRANCHES PER ROW	TOTAL NUMBER OF BRANCHES INCLUDING RED TIP BRANCHES	METAL BOTTOM RING OD INCHES	OD TREE IN INCHES	TOTAL NUMBER OF RGB STRANDS	TOTAL WATTS	NDB BOXES REQUIRED	AMPS REQUIRED BASED ON 110V	TOTAL WEIGHT IN LBS.
	Tree Top	5	0			52	4	50			
Number of Metal Frames	Pole	8	6	6		56	10	126			
		10	6	12		60	16	202			
1	A		6	18	20	72	22	277			267
1	B	14	8	26	30	80	30	378	1	3.15	395
1	C	16	8	34	40	90	38	479	2	3.99	516
2	D	18	12	46	50	100	50	630	2	5.25	664
2	E	20	14	60	60	110	64	806	2	6.72	844
2	F	22	18	78	70	120	82	1033	3	8.61	1043
2	G	24	20	98	80	130	102	1285	3	10.71	1303
4	H	26	24	122	90	140	126	1588	4	13.23	1596
4	I	28	28	150	100	150	154	1940	5	16.17	1896
4	J	30	28	178	110	160	182	2293	6	19.11	2229
4	K	32	32	210	120	170	214	2696.4	7	22.47	2595
4	L	34	36	246	130	180	250	3150	8	26.25	3012
4	M	36	40	286	140	190	290	3654	9	30.45	3556
6	N	38	42	328	150	200	332	4183.2	10	34.86	4191
6	O	40	42	370	160	210	374	4712.4	12	39.27	4795



THE RED RUN LINE PAINTED ON THE METAL FRAME:

The run line should face the back of the tree. This is your starting point. Diagrams provided are a top overview of the metal tree frame and all wiring will be done in a clockwise motion/direction.

SEQUOIA TREES: RGB WIRING DIAGRAM



30' RGB SEQUOIA TREE

TOPPER

- Red Branches 6 Branches - Special Red Tip
- Pole Branches 6 Branch - Standard

IMPORTANT NOTE: RGB lights are run by a computer generated animation. The cables feeding power also provide data. All electronic and data parts should be handled with care.

DO NOT KINK OR SMASH LIGHT STRANDS

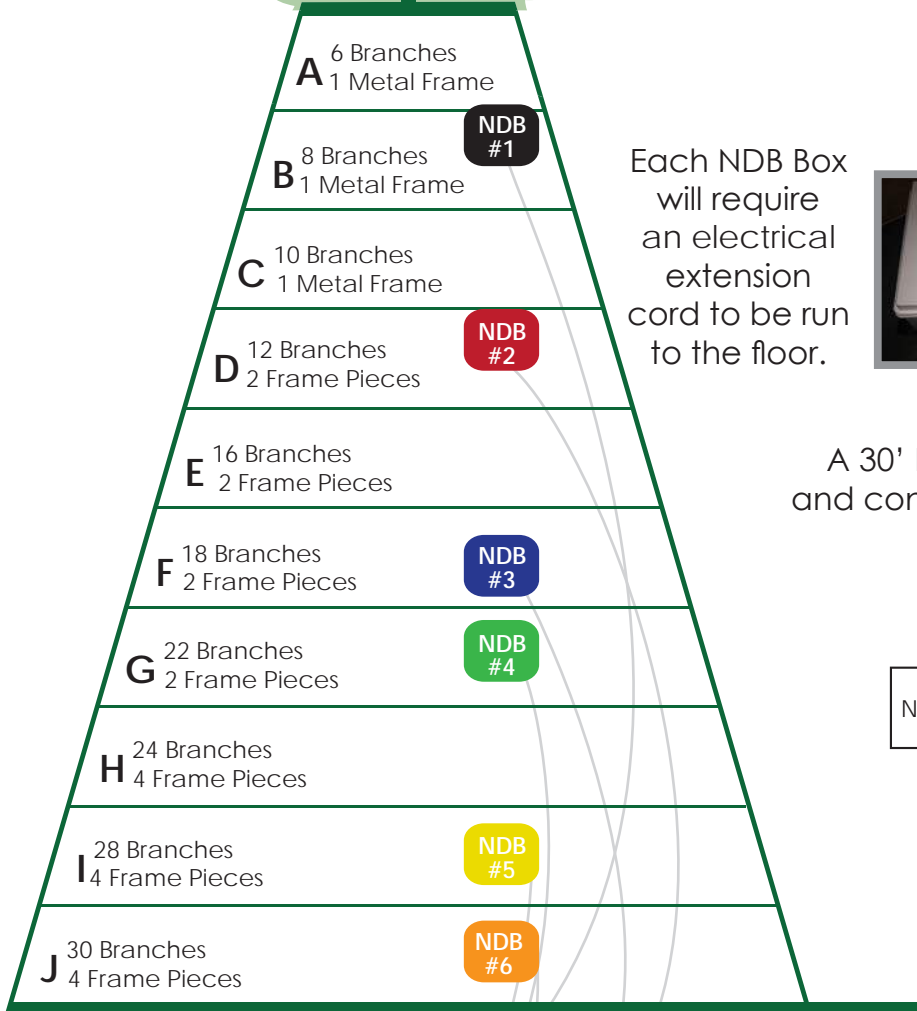

Each NDB Box will require an electrical extension cord to be run to the floor.



ACTUAL NDB

A 30' RGB Tree has 6 NDB's, all are 120 volt and connect to a switch port via CAT5 Cables

All NDB's (6 total for a 30' tree) connect to 1 switch via CAT5 cables as pictured below:

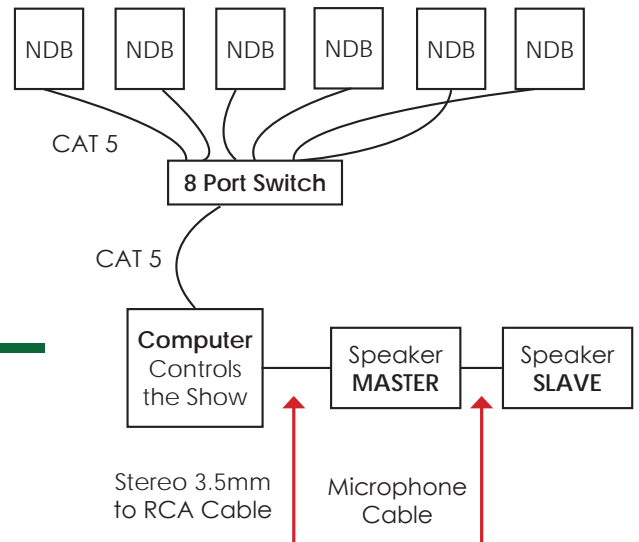

SIDE VIEW OF TREE

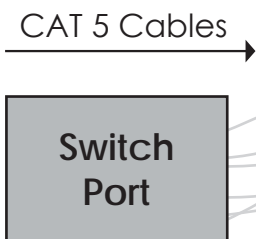

EXPLODED VIEW OF CONNECTIONS

SEQUOIA TREES: NDB CONNECTIONS



NDB Channels connect to the labeled NDB Data Cable Extenders pictured below

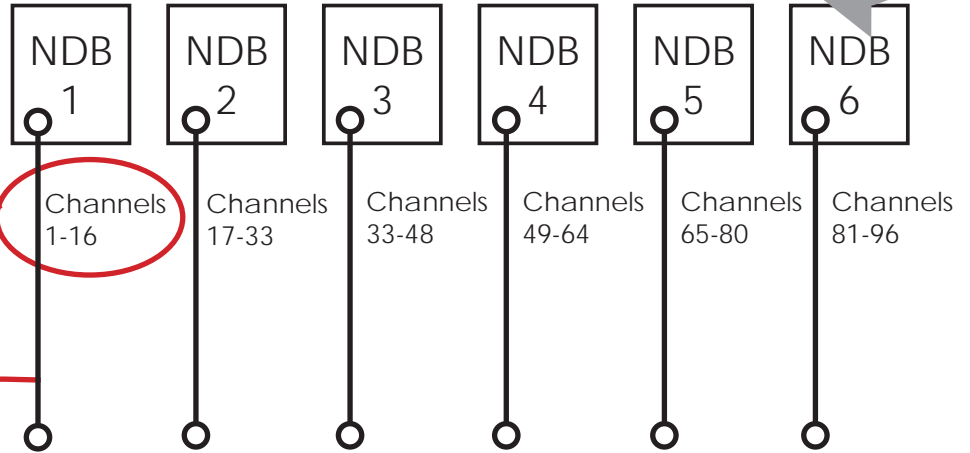

NDB outputs are numbered 1-206.

Branch #1A connects to the female end on branch #1, the male end on branch #1 connects to the NDB output #1



Data Cable Extenders are labeled on each end to match the NDB and the branch

IMPORTANT NOTE: RGB lights are run by a computer generated animation. The cables feeding power also provide data. All electronic and data parts should be handled with care.

DO NOT KINK OR SMASH LIGHT STRANDS



SEQUOIA TREES: RGB BRANCH CONFIGURATION



IMPORTANT NOTE: RGB lights should be installed in a clockwise motion.

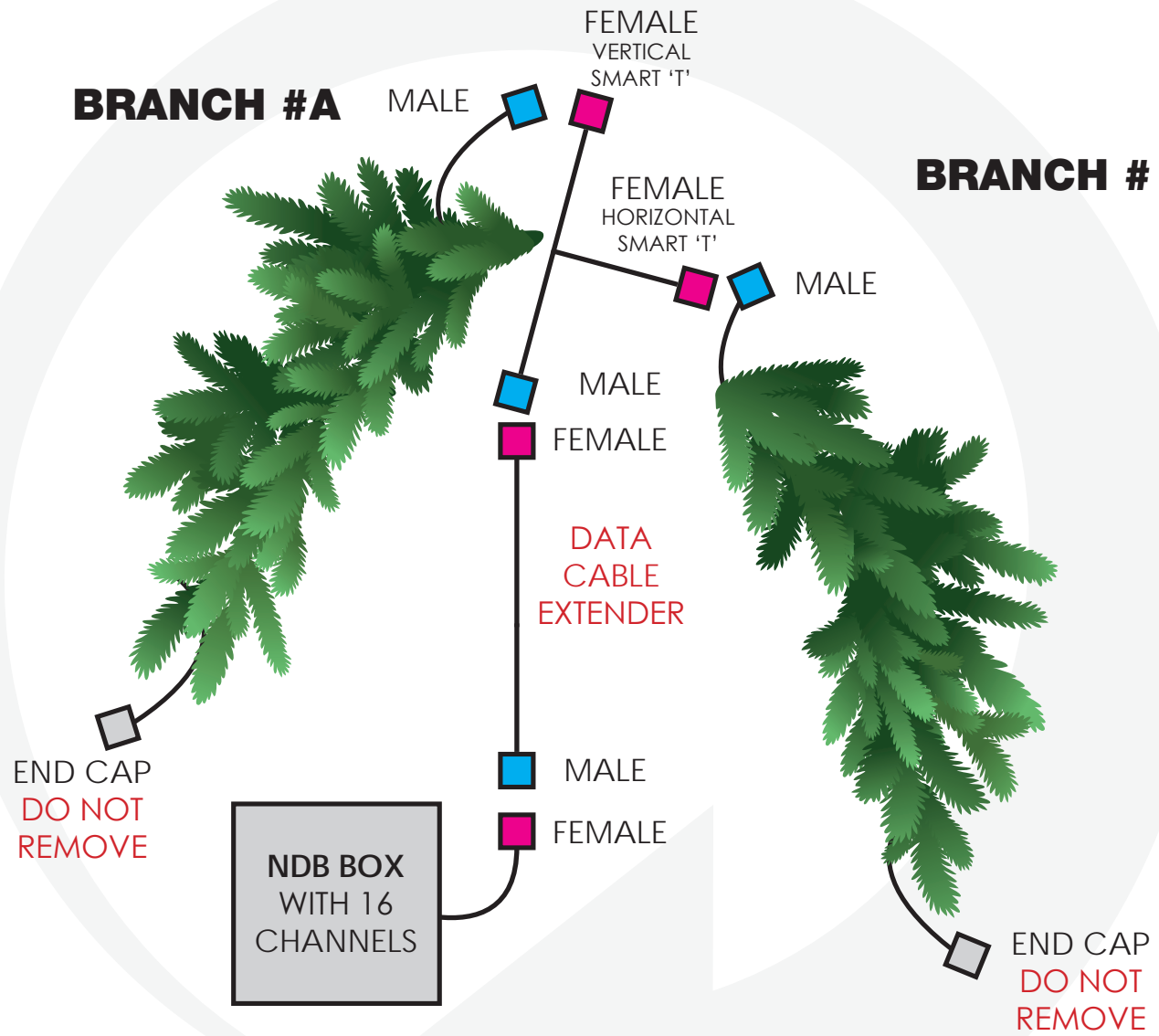

Female End



Male End



End Caps



Smart T



Data Cable Extender

SEQUOIA TREES: RGB INSTALLATION



The numbers next to NDB boxes indicates the number of cords and length required per channel

Ensure that all male ends have a secure o-ring; this is to prevent moisture from getting in. To secure the o-ring, squeeze to see the o-ring compress and push in tightly, seal and twist. Once tight, complete another 1/4 turn to fully secure it.

IDENTIFY ALL PARTS

- Metal Frames, branches, RGB boxes Switch Port, Data Cable Extenders etc
- Build metal frame based on **Sequoia Tree Instructions** (this tree will not have an electrical harness attached to metal frame)
- Barrel kit will be required to ballast tree. Options: water barrels, sand bags

ALL STANDARD BRANCHES ARE THE SAME AND CAN BE PLACED ANYWHERE

- *Metal Frame is labeled starting at the tree top*
- Each NDB box will require a separate extension cord to run down to the ground to be reset if necessary (NDB box has 16 Channels do not skip any channel, this will cause effects/programming to skip when displaying the light show) every NDB box will require a cat 5 Cable to be run down to the ground to be connected to a switch Board Box
- If the NDB box is turned on every time you plug in new channels/ strands; the power will have to be reset to allow new channels/ strands to light up. If the strand does not light while power is connected this is normal
- After placement of tree top, Locate RGB Cable Extender (18' Long) at the base of the tree topper labeled Channel #1 and Channel #2 and run down to NDB box #1 match channels accordingly.
- **POLE- RED TIP BRANCHES** Pole Inserts labeled 3 and 3A Place Smart T connector between both branches (3 is the First Branch to plug into vertical female closest to male connector on the smart "T" and 3A will plug into the horizontal female connector) Add cable extender (12'long) to Smart T and run down to NDB Box #1 Channel 3 (see diagram for reference)
- **POLE- RED TIP BRANCHES** Pole Inserts labeled 4 and 4A Place Smart T connector between both branches (4 is the First Branch to plug into vertical female closest to male connector on the smart "T" and 4A will plug into the horizontal female connector) Add cable extender (12'long) to Smart T and run down to NDB Box #1 Channel 4 (see diagram for reference)
- **POLE- RED TIP BRANCHES** Pole Inserts labeled 5 and 5A Place Smart T connector between both branches (5 is the First Branch to plug into vertical female closest to male connector on the smart "T" and 5A will plug into the horizontal female connector) Add cable extender (12'long) to Smart T and run down to NDB Box #1 Channel 5 (see diagram for reference)

 = Indicates the runline

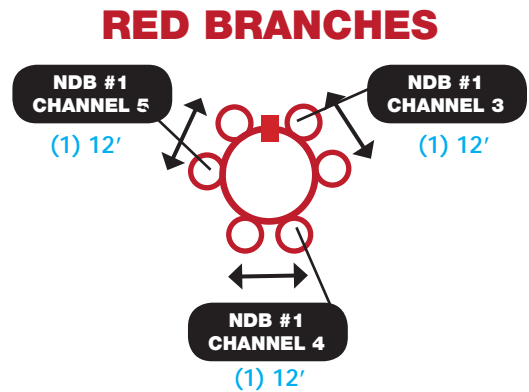
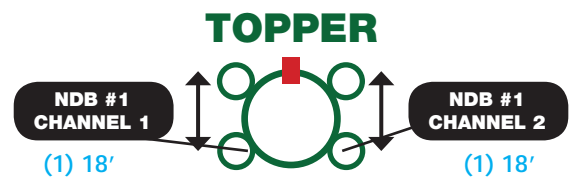

After each row of branches is completed remember to fluff branches/ reset power on NDB boxes to test lights.



POLE BRANCHES

- **POLE- REGULAR BRANCHES** Pole Inserts labeled 6 and 6A Place Smart T connector between both branches (6 is the First Branch to plug into vertical female closest to male connector on the smart "T" and 6A will plug into the horizontal female connector) Add cable extender (6'long) to Smart T and run down to NDB Box #1 Channel 6 (see diagram for reference)
- **POLE- REGULAR BRANCHES** POLE Inserts labeled 7 and 7A Place Smart T connector between both branches (7 is the First Branch to plug into vertical female closest to male connector on the smart "T" and 7A will plug into the horizontal female connector) Add cable extender (6'long) to Smart T and run down to NDB Box #1 Channel 7 (see diagram for reference)
- **POLE- REGULAR BRANCHES** Pole Inserts labeled 8 and 8A Place Smart T connector between both branches (8 is the First Branch to plug into vertical female closest to male connector on the smart "T" and 8A will plug into the horizontal female connector) Add cable extender (6'long) to Smart T and run down to NDB Box #1 Channel 8 (see diagram for reference)

After each row of branches is completed remember to fluff branches/ reset power on NDB boxes to test lights.

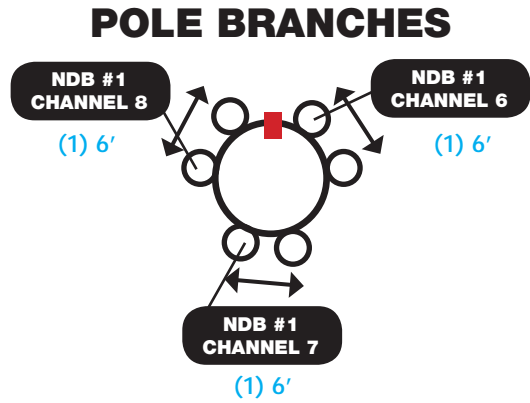

FRAME A

- **FRAME A REGULAR BRANCHES** Pole Inserts labeled 9 and 9A Place Smart T connector between both branches (9 is the First Branch to plug into vertical female closest to male connector on the smart "T" and 9A will plug into the horizontal female connector) Add cable extender (6'long) to Smart T and run down to NDB Box #1 Channel 9 (see diagram for reference)
- **FRAME A REGULAR BRANCHES** Pole Inserts labeled 10 and 10A Place Smart T connector between both branches (10 is the First Branch to plug into vertical female closest to male connector on the smart "T" and 10A will plug into the horizontal female connector) Add cable extender (6'long) to Smart T and run down to NDB Box #1 Channel 10 (see diagram for reference)
- **FRAME A REGULAR BRANCHES** Pole Inserts labeled 11 and 11A Place Smart T connector between both branches (11 is the First Branch to plug into vertical female closest to male connector on the smart "T" and 11A will plug into the horizontal female connector) Add cable extender (6'long) to Smart T and run down to NDB Box #1 Channel 11 (see diagram for reference)

After each row of branches is completed remember to fluff branches/ reset power on NDB boxes to test lights.

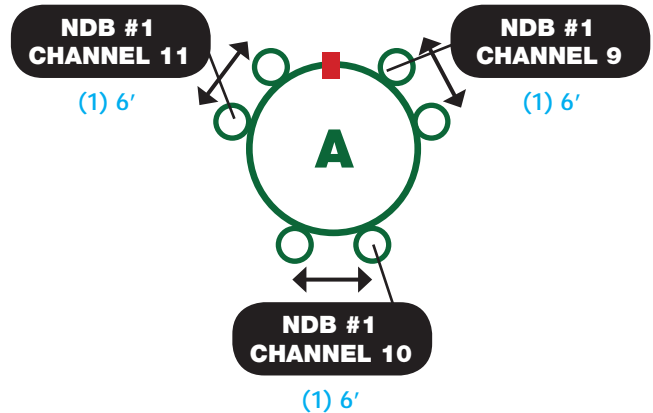

SEQUOIA TREES: RGB INSTALLATION



FRAME B

- **FRAME B REGULAR BRANCHES** Pole Inserts labeled 12 and 12A Place Smart T connector between both branches (12 is the First Branch to plug into vertical female closest to male connector on the smart "T" and 12A will plug into the horizontal female connector) Add cable extender (6'long) to Smart T and run down to NDB Box #1 Channel 12 (see diagram for reference)
- **FRAME B REGULAR BRANCHES** Pole Inserts labeled 13 and 13A Place Smart T connector between both branches (13 is the First Branch to plug into vertical female closest to male connector on the smart "T" and 13A will plug into the horizontal female connector) Add cable extender (6'long) to Smart T and run down to NDB Box #1 Channel 13 (see diagram for reference)
- **FRAME B REGULAR BRANCHES** Pole Inserts labeled 14 and 14A Place Smart T connector between both branches (14 is the First Branch to plug into vertical female closest to male connector on the smart "T" and 14A will plug into the horizontal female connector) Add cable extender (6'long) to Smart T and run down to NDB Box #1 Channel 14 (see diagram for reference)
- **FRAME B REGULAR BRANCHES** Pole Inserts labeled 15 and 15A Place Smart T connector between both branches (15 is the First Branch to plug into vertical female closest to male connector on the smart "T" and 15A will plug into the horizontal female connector) Add cable extender (6'long) to Smart T and run down to NDB Box #1 Channel 15 (see diagram for reference)

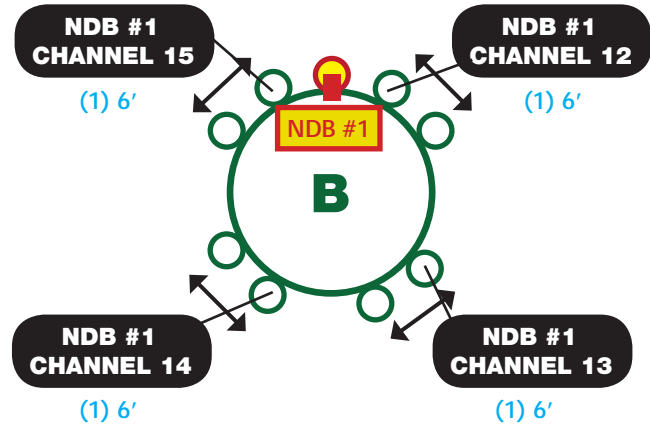

After each row of branches is completed remember to fluff branches/ reset power on NDB boxes to test lights.

FRAME C

- **FRAME C REGULAR BRANCHES** Pole Inserts labeled 16 and 16A Place Smart T connector between both branches (16 is the First Branch to plug into vertical female closest to male connector on the smart "T" and 16A will plug into the horizontal female connector) Add cable extender (12'long) to Smart T and run down to NDB Box #1 Channel 16 (see diagram for reference) this will be the last channel on NDB Box #1
- **FRAME C REGULAR BRANCHES** Pole Inserts labeled 17 and 17A Place Smart T connector between both branches (17 is the First Branch to plug into vertical female closest to male connector on the smart "T" and 17A will plug into the horizontal female connector) Add cable extender (12'long) to Smart T and run down to NDB Box #2 Channel 17 (see diagram for reference)
- **FRAME C REGULAR BRANCHES** Pole Inserts labeled 18 and 18A Place Smart T connector between both branches (18 is the First Branch to plug into vertical female closest to male connector on the smart "T" and 18A will plug into the horizontal female connector) Add cable extender (12'long) to Smart T and run down to NDB Box #2 Channel 18 (see diagram for reference)
- **FRAME C REGULAR BRANCHES** Pole Inserts labeled 19 and 19A Place Smart T connector between both branches (19 is the First Branch to plug into vertical female closest to male connector on the smart "T" and 19A will plug into the horizontal female connector) Add cable extender (12'long) to Smart T and run down to NDB Box #2 Channel 19 (see diagram for reference)

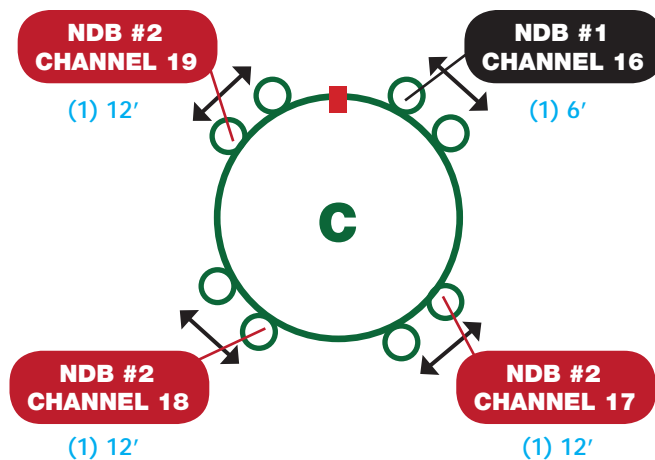

After each row of branches is completed remember to fluff branches/ reset power on NDB boxes to test lights.

SEQUOIA TREES: RGB INSTALLATION

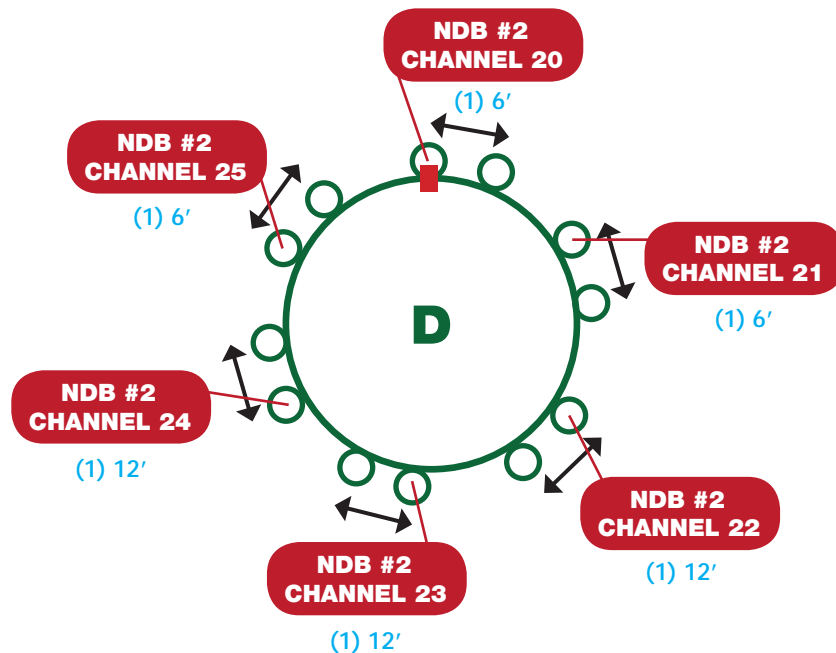

FRAME D

- **FRAME D REGULAR BRANCHES** Pole Inserts labeled 20 and 20A Place Smart T connector between both branches (20 is the First Branch to plug into vertical female closest to male connector on the smart "T" and 20A will plug into the horizontal female connector) Add cable extender (6'long) to Smart T and run down to NDB Box #2 Channel 20 (see diagram for reference)
- **FRAME D REGULAR BRANCHES** Pole Inserts labeled 21 and 21A Place Smart T connector between both branches (21 is the First Branch to plug into vertical female closest to male connector on the smart "T" and 21A will plug into the horizontal female connector) Add cable extender (6'long) to Smart T and run down to NDB Box #2 Channel 21 (see diagram for reference)
- **FRAME D REGULAR BRANCHES** Pole Inserts labeled 22 and 22A Place Smart T connector between both branches (22 is the First Branch to plug into vertical female closest to male connector on the smart "T" and 22A will plug into the horizontal female connector) Add cable extender (12'long) to Smart T and run down to NDB Box #2 Channel 22 (see diagram for reference)
- **FRAME D REGULAR BRANCHES** Pole Inserts labeled 23 and 23A Place Smart T connector between both branches (23 is the First Branch to plug into vertical female closest to male connector on the smart "T" and 23A will plug into the horizontal female connector) Add cable extender (12'long) to Smart T and run down to NDB Box #2 Channel 23 (see diagram for reference)
- **FRAME D REGULAR BRANCHES** Pole Inserts labeled 24 and 24A Place Smart T connector between both branches (24 is the First Branch to plug into vertical female closest to male connector on the smart "T" and 24A will plug into the horizontal female connector) Add cable extender (12'long) to Smart T and run down to NDB Box #2 Channel 24 (see diagram for reference)
- **FRAME D REGULAR BRANCHES** Pole Inserts labeled 25 and 25A Place Smart T connector between both branches (25 is the First Branch to plug into vertical female closest to male connector on the smart "T" and 25A will plug into the horizontal female connector) Add cable extender (6'long) to Smart T and run down to NDB Box #2 Channel 25 (see diagram for reference)

After each row of branches is completed remember to fluff branches/ reset power on NDB boxes to test lights.

SEQUOIA TREES: RGB INSTALLATION

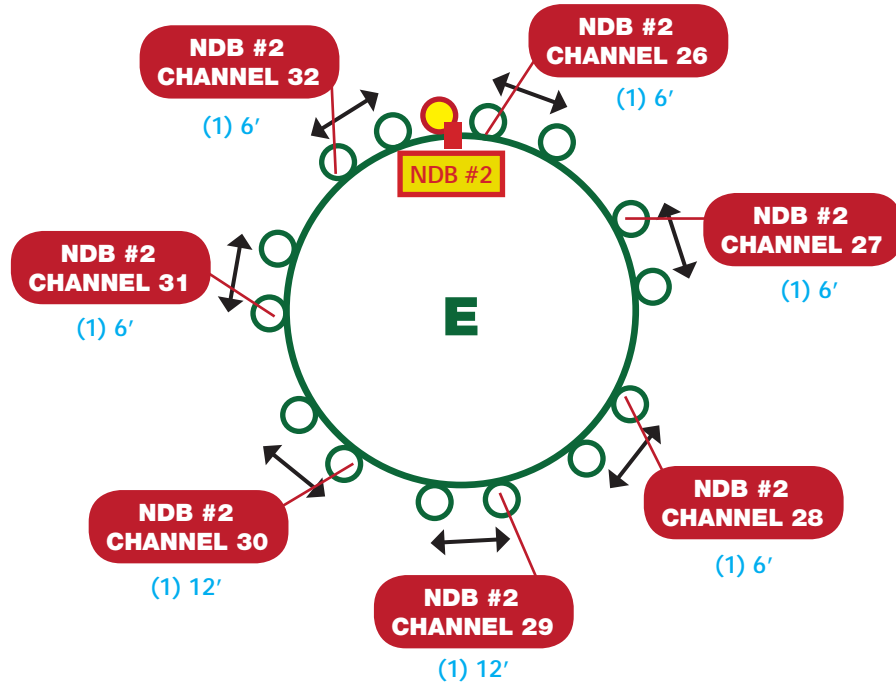

FRAME E

- FRAME E REGULAR BRANCHES Pole Inserts labeled 26 and 26A**
 Place Smart T connector between both branches (26 is the First Branch to plug into vertical female closest to male connector on the smart "T" and 26A will plug into the horizontal female connector) Add cable extender (6'long) to Smart T and run down to NDB Box #2 Channel 26 (see diagram for reference)
- FRAME E REGULAR BRANCHES Pole Inserts labeled 27 and 27A**
 Place Smart T connector between both branches (27 is the First Branch to plug into vertical female closest to male connector on the smart "T" and 27A will plug into the horizontal female connector) Add cable extender (6'long) to Smart T and run down to NDB Box #2 Channel 27 (see diagram for reference)
- FRAME E REGULAR BRANCHES Pole Inserts labeled 28 and 28A**
 Place Smart T connector between both branches (28 is the First Branch to plug into vertical female closest to male connector on the smart "T" and 28A will plug into the horizontal female connector) Add cable extender (6'long) to Smart T and run down to NDB Box #2 Channel 28 (see diagram for reference)
- FRAME E REGULAR BRANCHES Pole Inserts labeled 29 and 29A**
 Place Smart T connector between both branches (29 is the First Branch to plug into vertical female closest to male connector on the smart "T" and 29A will plug into the horizontal female connector) Add cable extender (12'long) to Smart T and run down to NDB Box #2 Channel 29 (see diagram for reference)
- FRAME E REGULAR BRANCHES Pole Inserts labeled 30 and 30A**
 Place Smart T connector between both branches (30 is the First Branch to plug into vertical female closest to male connector on the smart "T" and 30A will plug into the horizontal female connector) Add cable extender (12'long) to Smart T and run down to NDB Box #2 Channel 30 (see diagram for reference)
- FRAME E REGULAR BRANCHES Pole Inserts labeled 31 and 31A**
 Place Smart T connector between both branches (31 is the First Branch to plug into vertical female closest to male connector on the smart "T" and 31A will plug into the horizontal female connector) Add cable extender (6'long) to Smart T and run down to NDB Box #2 Channel 31 (see diagram for reference)
- FRAME E REGULAR BRANCHES Pole Inserts labeled 32 and 32A**
 Place Smart T connector between both branches (32 is the First Branch to plug into vertical female closest to male connector on the smart "T" and 32A will plug into the horizontal female connector) Add cable extender (6'long) to Smart T and run down to NDB Box #2 Channel 32 (see diagram for reference) this will be the last channel on NDB Box #2

After each row of branches is completed remember to fluff branches/ reset power on NDB boxes to test lights.



FRAME F

• **FRAME F REGULAR BRANCHES Pole** Inserts labeled 33 and 33A Place Smart T connector between both branches (33 is the First Branch to plug into vertical female closest to male connector on the smart "T" and 33A will plug into the horizontal female connector) Add cable extender (6'long) to Smart T and run down to NDB Box #3 Channel 33 (see diagram for reference)

• **FRAME F REGULAR BRANCHES Pole** Inserts labeled 34 and 34A Place Smart T connector between both branches (34 is the First Branch to plug into vertical female closest to male connector on the smart "T" and 34A will plug into the horizontal female connector) Add cable extender (6'long) to Smart T and run down to NDB Box #3 Channel 34 (see diagram for reference)

• **FRAME F REGULAR BRANCHES Pole** Inserts labeled 35 and 35A Place Smart T connector between both branches (35 is the First Branch to plug into vertical female closest to male connector on the smart "T" and 35A will plug into the horizontal female connector) Add cable extender (6'long) to Smart T and run down to NDB Box #3 Channel 34 (see diagram for reference)

• **FRAME F REGULAR BRANCHES Pole** Inserts labeled 36 and 36A Place Smart T connector between both branches (36 is the First Branch to plug into vertical female closest to male connector on the smart "T" and 36A will plug into the horizontal female connector) Add cable extender (12'long) to Smart T and run down to NDB Box #3 Channel 36 (see diagram for reference)

• **FRAME F REGULAR BRANCHES Pole** Inserts labeled 37 and 37A Place Smart T connector between both branches (37 is the First Branch to plug into vertical female closest to male connector on the smart "T" and 37A will plug into the horizontal female connector) Add cable extender (12'long) to Smart T and run down to NDB Box #3 Channel 37 (see diagram for reference)

• **FRAME F REGULAR BRANCHES Pole** Inserts labeled 38 and 38A Place Smart T connector between both branches (38 is the First Branch to plug into vertical female closest to male connector on the smart "T" and 38A will plug into the horizontal female connector) Add cable extender (12'long) to Smart T and run down to NDB Box #3 Channel 38 (see diagram for reference)

• **FRAME F REGULAR BRANCHES Pole** Inserts labeled 39 and 39A Place Smart T connector between both branches (39 is the First Branch to plug into vertical female closest to male connector on the smart "T" and 39A will plug into the horizontal female connector) Add cable extender (12'long) to Smart T and run down to NDB Box #3 Channel 39 (see diagram for reference)

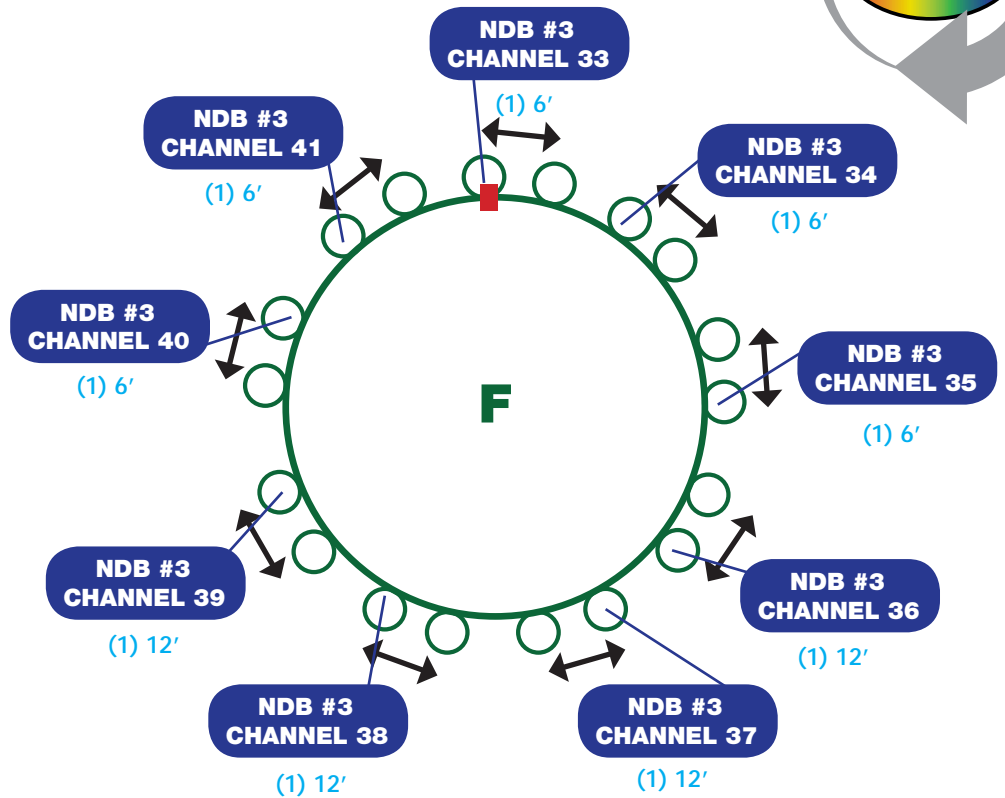

• **FRAME F REGULAR BRANCHES Pole** Inserts labeled 40 and 40A Place Smart T connector between both branches (40 is the First Branch to plug into vertical female closest to male connector on the smart "T" and 40A will plug into the horizontal female connector) Add cable extender (6'long) to Smart T and run down to NDB Box #3 Channel 40 (see diagram for reference)

• **FRAME F REGULAR BRANCHES Pole** Inserts labeled 41 and 41A Place Smart T connector between both branches (41 is the First Branch to plug into vertical female closest to male connector on the smart "T" and 41A will plug into the horizontal female connector) Add cable extender (6'long) to Smart T and run down to NDB Box #3 Channel 41 (see diagram for reference)

After each row of branches is completed remember to fluff branches/ reset power on NDB boxes to test lights.

SEQUOIA TREES: RGB INSTALLATION



FRAME G

- **FRAME G REGULAR BRANCHES** Pole Inserts labeled 42 and 42A Place Smart T connector between both branches (42 is the First Branch to plug into vertical female closest to male connector on the smart "T" and 42A will plug into the horizontal female connector) Add cable extender (6'long) to Smart T and run down to NDB Box #3 Channel 42 (see diagram for reference)

- **FRAME G REGULAR BRANCHES** Pole Inserts labeled 43 and 43A Place Smart T connector between both branches (43 is the First Branch to plug into vertical female closest to male connector on the smart "T" and 43A will plug into the horizontal female connector) Add cable extender (6'long) to Smart T and run down to NDB Box #3 Channel 43 (see diagram for reference)

- **FRAME G REGULAR BRANCHES** Pole Inserts labeled 44 and 44A Place Smart T connector between both branches (44 is the First Branch to plug into vertical female closest to male connector on the smart "T" and 44A will plug into the horizontal female connector) Add cable extender (6'long) to Smart T and run down to NDB Box #3 Channel 44 (see diagram for reference)

- **FRAME G REGULAR BRANCHES** Pole Inserts labeled 45 and 45A Place Smart T connector between both branches (45 is the First Branch to plug into vertical female closest to male connector on the smart "T" and 45A will plug into the horizontal female connector) Add cable extender (6'long) to Smart T and run down to NDB Box #3 Channel 45 (see diagram for reference)

- **FRAME G REGULAR BRANCHES** Pole Inserts labeled 46 and 46A Place Smart T connector between both branches (46 is the First Branch to plug into vertical female closest to male connector on the smart "T" and 46A will plug into the horizontal female connector) Add cable extender (12'long) to Smart T and run down to NDB Box #3 Channel 46 (see diagram for reference)

- **FRAME G REGULAR BRANCHES** Pole Inserts labeled 47 and 47A Place Smart T connector between both branches (47 is the First Branch to plug into vertical female closest to male connector on the smart "T" and 47A will plug into the horizontal female connector) Add cable extender (12'long) to Smart T and run down to NDB Box #3 Channel 47 (see diagram for reference)

- **FRAME G REGULAR BRANCHES** Pole Inserts labeled 48 and 48A Place Smart T connector between both branches (48 is the First Branch to plug into vertical female closest to male connector on the smart "T" and 48A will plug into the horizontal female connector) Add cable extender (12'long) to Smart T and run down to NDB Box #3 Channel 48 (see diagram for reference) this will be the last channel on NDB Box #3

- **FRAME G REGULAR BRANCHES** Pole Inserts labeled 49 and 49A Place Smart T connector between both branches (49 is the First Branch to plug into vertical female closest to male connector on the smart "T" and 49A will plug into the horizontal female connector) Add cable extender (12'long) to Smart T and run down to NDB Box #4 Channel 49 (see diagram for reference)

- **FRAME G REGULAR BRANCHES** Pole Inserts labeled 50 and 50A Place Smart T connector between both branches (50 is the First Branch to plug into vertical female closest to male connector on the smart "T" and 50A will plug into the horizontal female connector) Add cable extender (6'long) to Smart T and run down to NDB Box #4 Channel 50 (see diagram for reference)

- **FRAME G REGULAR BRANCHES** Pole Inserts labeled 51 and 51A Place Smart T connector between both branches (51 is the First Branch to plug into vertical female closest to male connector on the smart "T" and 51A will plug into the horizontal female connector) Add cable extender (6'long) to Smart T and run down to NDB Box #4 Channel 51 (see diagram for reference)

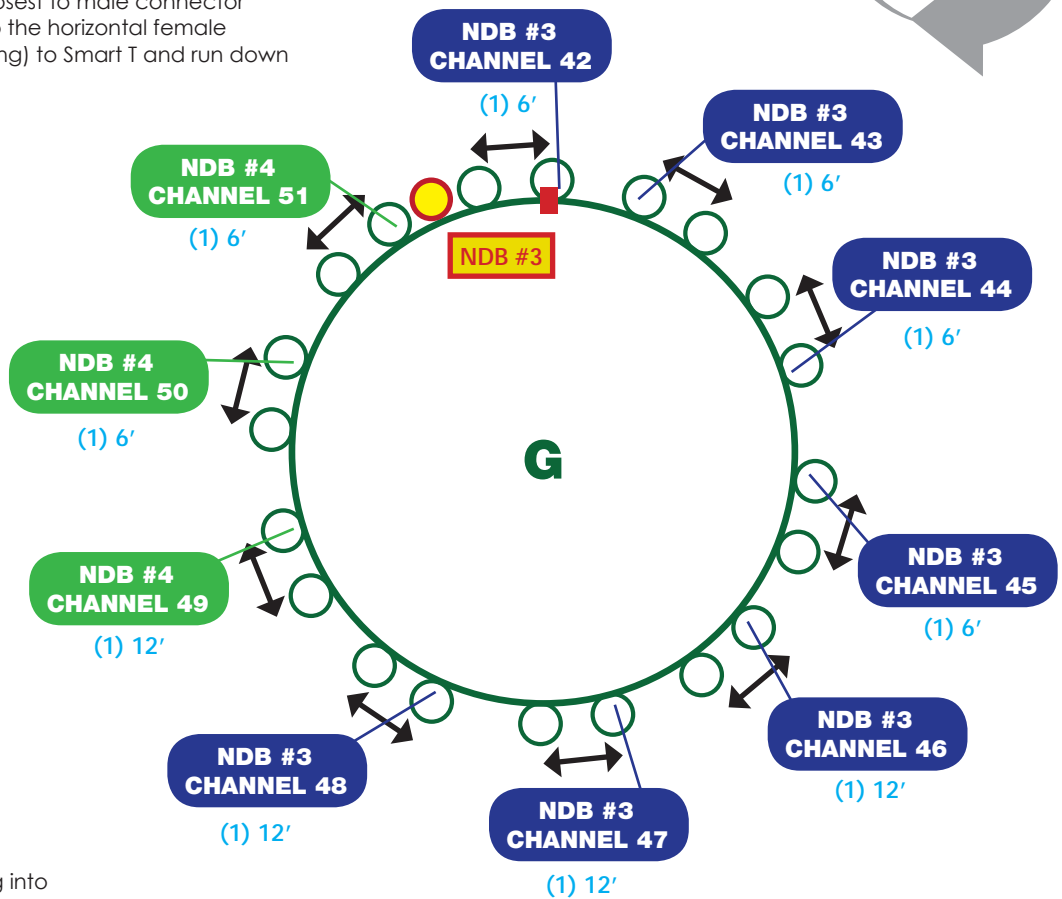

After each row of branches is completed remember to fluff branches/ reset power on NDB boxes to test lights.

SEQUOIA TREES: RGB INSTALLATION

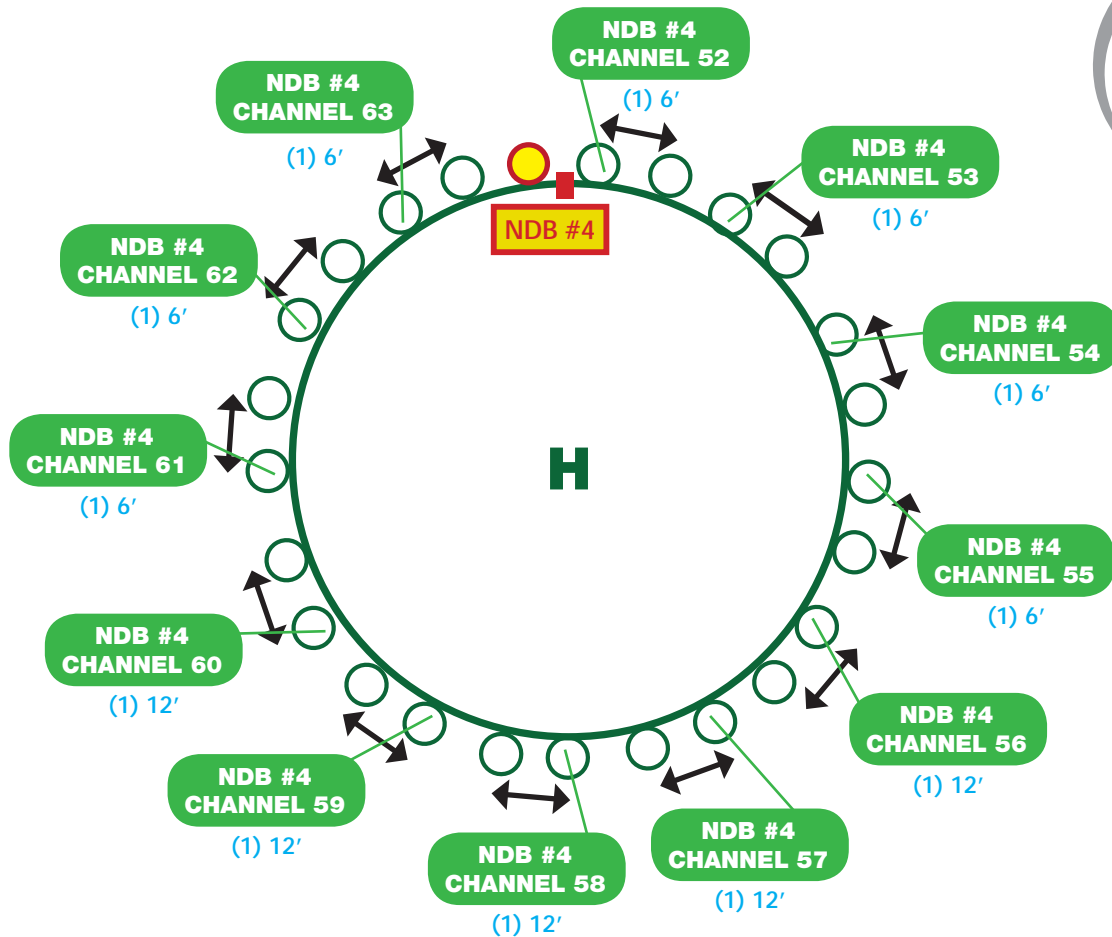

FRAME H

- FRAME H REGULAR BRANCHES Pole Inserts labeled 52 and 52A**
 Place Smart T connector between both branches (52 is the First Branch to plug into vertical female closest to male connector on the smart "T" and 52A will plug into the horizontal female connector) Add cable extender (6' long) to Smart T and run down to NDB Box #4 Channel 52 (see diagram for reference)
- FRAME H REGULAR BRANCHES Pole Inserts labeled 53 and 53A**
 Place Smart T connector between both branches (53 is the First Branch to plug into vertical female closest to male connector on the smart "T" and 53A will plug into the horizontal female connector) Add cable extender (6' long) to Smart T and run down to NDB Box #4 Channel 53 (see diagram for reference)
- FRAME H REGULAR BRANCHES POLE Inserts labeled 54 and 54A**
 Place Smart T connector between both branches (54 is the First Branch to plug into vertical female closest to male connector on the smart "T" and 54A will plug into the horizontal female connector) Add cable extender (6' long) to Smart T and run down to NDB Box #4 Channel 54 (see diagram for reference)
- FRAME H REGULAR BRANCHES Pole Inserts labeled 55 and 55A**
 Place Smart T connector between both branches (55 is the First Branch to plug into vertical female closest to male connector on the smart "T" and 55A will plug into the horizontal female connector) Add cable extender (6' long) to Smart T and run down to NDB Box #4 Channel 55 (see diagram for reference)
- FRAME H REGULAR BRANCHES Pole Inserts labeled 56 and 56A**
 Place Smart T connector between both branches (56 is the First Branch to plug into vertical female closest to male connector on the smart "T" and 56A will plug into the horizontal female connector) Add cable extender (12' long) to Smart T and run down to NDB Box #4 Channel 56 (see diagram for reference)
- FRAME H REGULAR BRANCHES Pole Inserts labeled 57 and 57A**
 Place Smart T connector between both branches (57 is the First Branch to plug into vertical female closest to male connector on the smart "T" and 57A will plug into the horizontal female connector) Add cable extender (12' long) to Smart T and run down to NDB Box #4 Channel 57 (see diagram for reference)
- FRAME H REGULAR BRANCHES Pole Inserts labeled 58 and 58A**
 Place Smart T connector between both branches (58 is the First Branch to plug into vertical female closest to male connector on the smart "T" and 58A will plug into the horizontal female connector) Add cable extender (12' long) to Smart T and run down to NDB Box #4 Channel 58 (see diagram for reference)

**CONTINUED ON
NEXT PAGE ...**

SEQUOIA TREES: RGB TREE WIRING LAYOUT

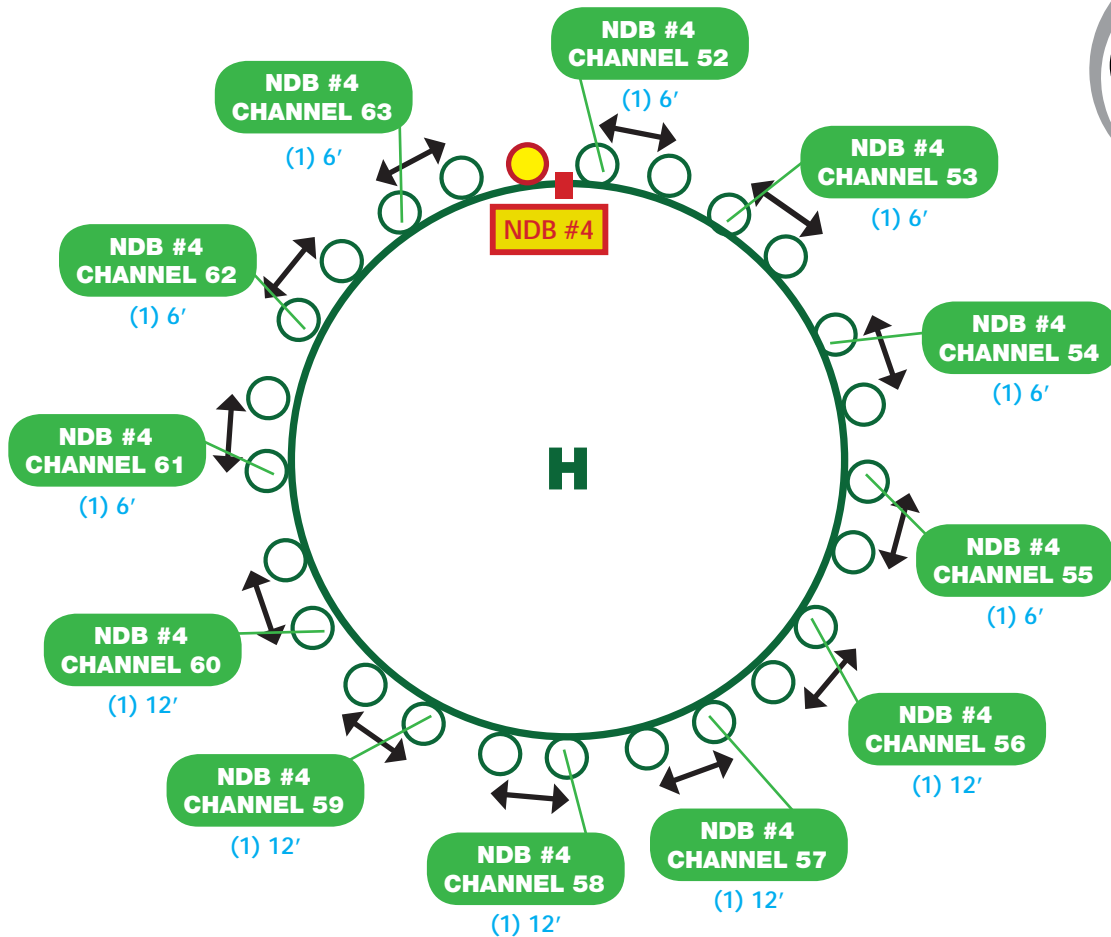

FRAME H

CONTINUED FROM PREVIOUS PAGE ...

- **FRAME H REGULAR BRANCHES** Pole Inserts labeled 59 and 59A Place Smart T connector between both branches (59 is the First Branch to plug into vertical female closest to male connector on the smart "T" and 59A will plug into the horizontal female connector) Add cable extender (12'long) to Smart T and run down to NDB Box #4 Channel 59 (see diagram for reference)
- **FRAME H REGULAR BRANCHES** Pole Inserts labeled 60 and 60A Place Smart T connector between both branches (60 is the First Branch to plug into vertical female closest to male connector on the smart "T" and 60A will plug into the horizontal female connector) Add cable extender (12'long) to Smart T and run down to NDB Box #4 Channel 60 (see diagram for reference)
- **FRAME H REGULAR BRANCHES** Pole Inserts labeled 61 and 61A Place Smart T connector between both branches (61 is the First Branch to plug into vertical female closest to male connector on the smart "T" and 61A will plug into the horizontal female connector) Add cable extender (6'long) to Smart T and run down to NDB Box #4 Channel 61 (see diagram for reference)
- **FRAME H REGULAR BRANCHES** Pole Inserts labeled 62 and 62A Place Smart T connector between both branches (62 is the First Branch to plug into vertical female closest to male connector on the smart "T" and 62A will plug into the horizontal female connector) Add cable extender (6'long) to Smart T and run down to NDB Box #4 Channel 62 (see diagram for reference)
- **FRAME H REGULAR BRANCHES** Pole Inserts labeled 63 and 63A Place Smart T connector between both branches (63 is the First Branch to plug into vertical female closest to male connector on the smart "T" and 63A will plug into the horizontal female connector) Add cable extender (6'long) to Smart T and run down to NDB Box #4 Channel 63 (see diagram for reference)

After each row of branches is completed remember to fluff branches/ reset power on NDB boxes to test lights.

SEQUOIA TREES: RGB INSTALLATION

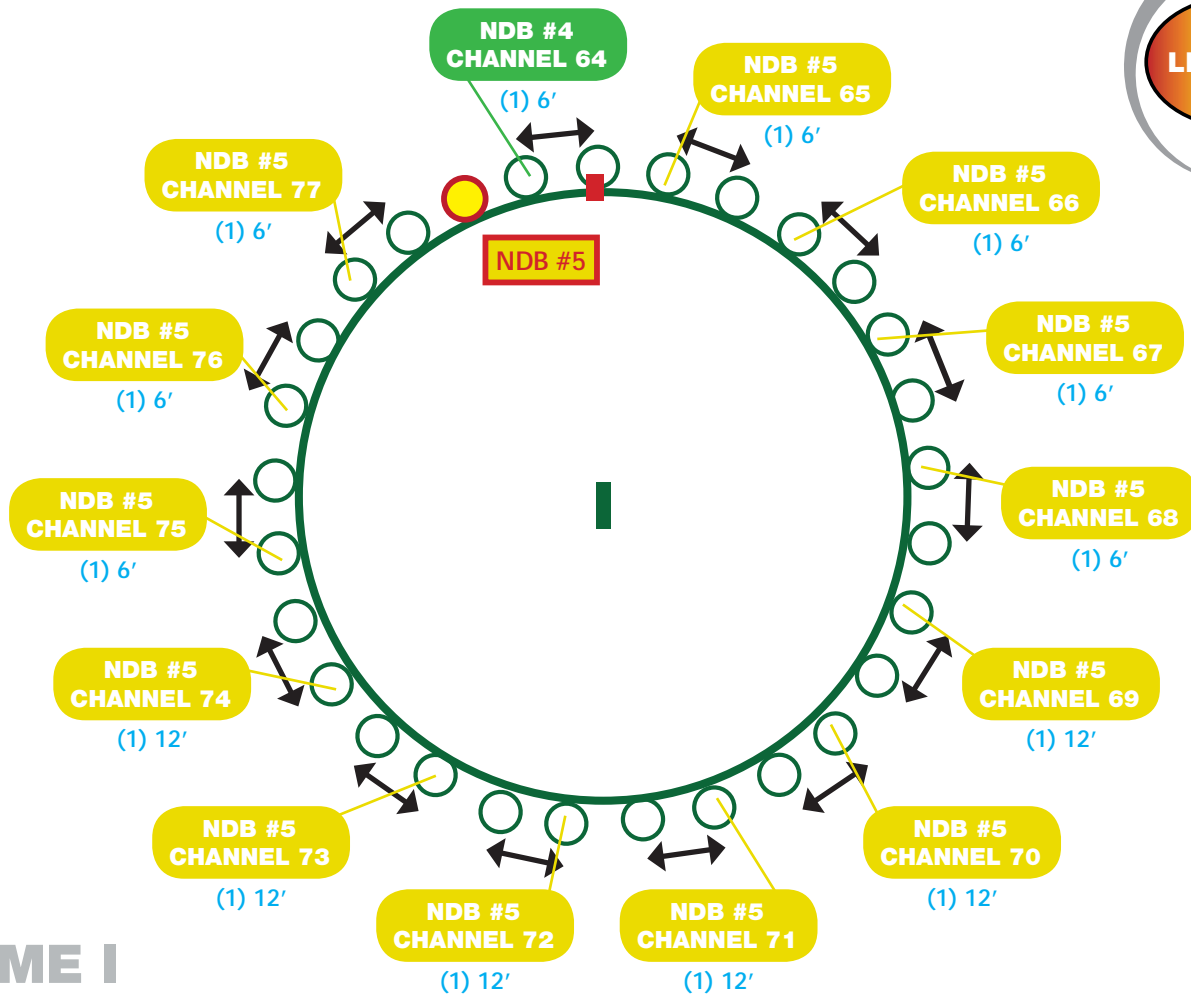

FRAME I

- FRAME I REGULAR BRANCHES Pole Inserts labeled 64 and 64A** Place Smart T connector between both branches (64 is the First Branch to plug into vertical female closest to male connector on the smart "T" and 64A will plug into the horizontal female connector) Add cable extender (6'long) to Smart T and run down to NDB Box #4 Channel 64 (see diagram for reference) this will be the last channel on NDB Box #4
- FRAME I REGULAR BRANCHES Pole Inserts labeled 65 and 65A** Place Smart T connector between both branches (65 is the First Branch to plug into vertical female closest to male connector on the smart "T" and 65A will plug into the horizontal female connector) Add cable extender (6'long) to Smart T and run down to NDB Box #5 Channel 65 (see diagram for reference)
- FRAME I REGULAR BRANCHES Pole Inserts labeled 66 and 66A** Place Smart T connector between both branches (66 is the First Branch to plug into vertical female closest to male connector on the smart "T" and 66A will plug into the horizontal female connector) Add cable extender (6'long) to Smart T and run down to NDB Box #5 Channel 66 (see diagram for reference)
- FRAME I REGULAR BRANCHES Pole Inserts labeled 67 and 67A** Place Smart T connector between both branches (67 is the First Branch to plug into vertical female closest to male connector on the smart "T" and 67A will plug into the horizontal female connector) Add cable extender (6'long) to Smart T and run down to NDB Box #5 Channel 67 (see diagram for reference)
- FRAME I REGULAR BRANCHES Pole Inserts labeled 68 and 68A** Place Smart T connector between both branches (68 is the First Branch to plug into vertical female closest to male connector on the smart "T" and 68A will plug into the horizontal female connector) Add cable extender (6'long) to Smart T and run down to NDB Box #5 Channel 68 (see diagram for reference)
- FRAME I REGULAR BRANCHES Pole Inserts labeled 69 and 69A** Place Smart T connector between both branches (69 is the First Branch to plug into vertical female closest to male connector on the smart "T" and 69A will plug into the horizontal female connector) Add cable extender (12'long) to Smart T and run down to NDB Box #5 Channel 69 (see diagram for reference)
- FRAME I REGULAR BRANCHES Pole Inserts labeled 70 and 70A** Place Smart T connector between both branches (70 is the First Branch to plug into vertical female closest to male connector on the smart "T" and 70A will plug into the horizontal female connector) Add cable extender (12'long) to Smart T and run down to NDB Box #5 Channel 70 (see diagram for reference)
- FRAME I REGULAR BRANCHES Pole Inserts labeled 71 and 71A** Place Smart T connector between both branches (71 is the First Branch to plug into vertical female closest to male connector on the smart "T" and 71A will plug into the horizontal female connector) Add cable extender (12'long) to Smart T and run down to NDB Box #5 Channel 71 (see diagram for reference)

CONTINUED ON NEXT PAGE ...

SEQUOIA TREES: RGB INSTALLATION

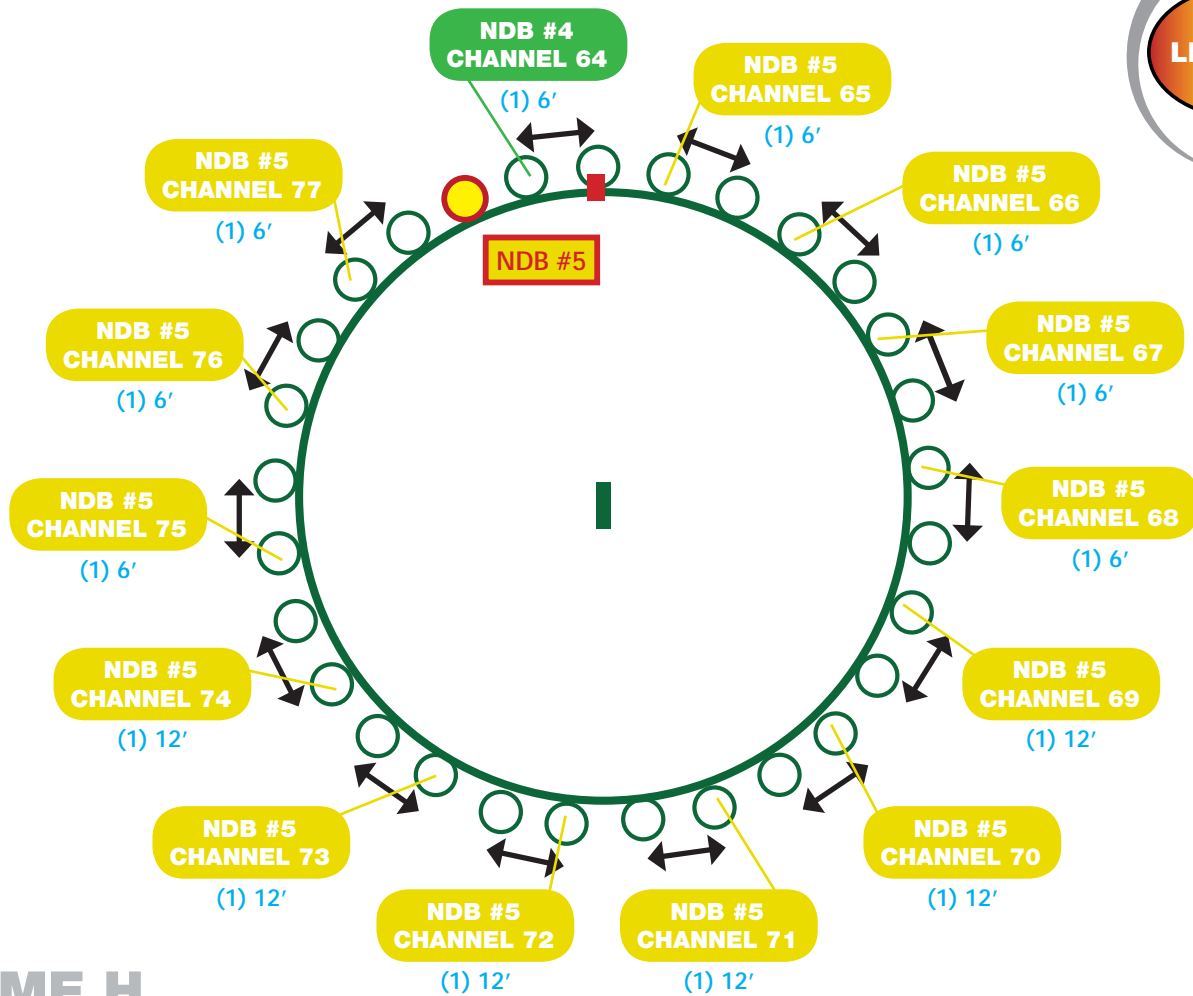

FRAME H

CONTINUED FROM PREVIOUS PAGE ...

- FRAME I REGULAR BRANCHES Pole Inserts labeled 72 and 72A**
 Place Smart T connector between both branches (72 is the First Branch to plug into vertical female closest to male connector on the smart "T" and 72A will plug into the horizontal female connector) Add cable extender (12'long) to Smart T and run down to NDB Box #5 Channel 72 (see diagram for reference)
- FRAME I REGULAR BRANCHES Pole Inserts labeled 73 and 73A**
 Place Smart T connector between both branches (73 is the First Branch to plug into vertical female closest to male connector on the smart "T" and 73A will plug into the horizontal female connector) Add cable extender (12'long) to Smart T and run down to NDB Box #5 Channel 73 (see diagram for reference)
- FRAME I REGULAR BRANCHES Pole Inserts labeled 74 and 74A**
 Place Smart T connector between both branches (74 is the First Branch to plug into vertical female closest to male connector on the smart "T" and 74A will plug into the horizontal female connector) Add cable extender (12'long) to Smart T and run down to NDB Box #5 Channel 74 (see diagram for reference)
- FRAME I REGULAR BRANCHES Pole Inserts labeled 75 and 75A**
 Place Smart T connector between both branches (75 is the First Branch to plug into vertical female closest to male connector on the smart "T" and 75A will plug into the horizontal female connector) Add cable extender (6'long) to Smart T and run down to NDB Box #5 Channel 75 (see diagram for reference)
- FRAME I REGULAR BRANCHES Pole Inserts labeled 76 and 76A**
 Place Smart T connector between both branches (76 is the First Branch to plug into vertical female closest to male connector on the smart "T" and 76A will plug into the horizontal female connector) Add cable extender (6'long) to Smart T and run down to NDB Box #5 Channel 76 (see diagram for reference)
- FRAME I REGULAR BRANCHES Pole Inserts labeled 77 and 77A**
 Place Smart T connector between both branches (77 is the First Branch to plug into vertical female closest to male connector on the smart "T" and 77A will plug into the horizontal female connector) Add cable extender (6'long) to Smart T and run down to NDB Box #5 Channel 77 (see diagram for reference)

After each row of branches is completed remember to fluff branches/ reset power on NDB boxes to test lights.

SEQUOIA TREES: RGB INSTALLATION

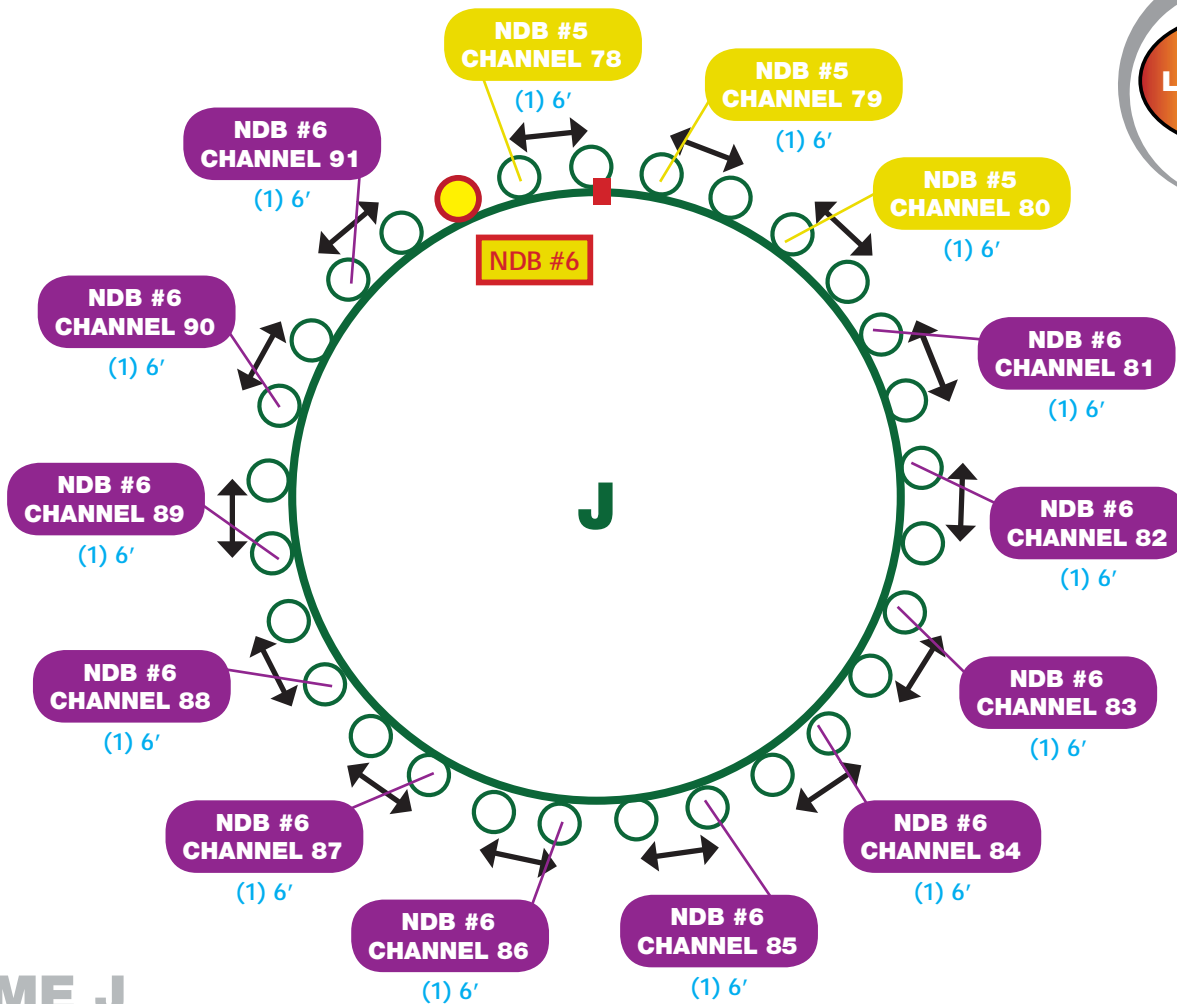

FRAME J

- FRAME J REGULAR BRANCHES Pole Inserts labeled 78 and 78A**
 Place Smart T connector between both branches (78 is the First Branch to plug into vertical female closest to male connector on the smart "T" and 78A will plug into the horizontal female connector) Add cable extender (6' long) to Smart T and run down to NDB Box #5 Channel 78 (see diagram for reference)
- FRAME J REGULAR BRANCHES Pole Inserts labeled 79 and 79A**
 Place Smart T connector between both branches (79 is the First Branch to plug into vertical female closest to male connector on the smart "T" and 79A will plug into the horizontal female connector) Add cable extender (6' long) to Smart T and run down to NDB Box #5 Channel 79 (see diagram for reference)
- FRAME J REGULAR BRANCHES Pole Inserts labeled 80 and 80A**
 Place Smart T connector between both branches (80 is the First Branch to plug into vertical female closest to male connector on the smart "T" and 80A will plug into the horizontal female connector) Add cable extender (6' long) to Smart T and run down to NDB Box #5 Channel 80 (see diagram for reference) this will be the last channel on NDB Box #5
- FRAME J REGULAR BRANCHES Pole Inserts labeled 81 and 81A**
 Place Smart T connector between both branches (81 is the First Branch to plug into vertical female closest to male connector on the smart "T" and 81A will plug into the horizontal female connector) Add cable extender (6' long) to Smart T and run down to NDB Box #6 Channel 81 (see diagram for reference)
- FRAME J REGULAR BRANCHES Pole Inserts labeled 82 and 82A**
 Place Smart T connector between both branches (82 is the First Branch to plug into vertical female closest to male connector on the smart "T" and 82A will plug into the horizontal female connector) Add cable extender (12' long) to Smart T and run down to NDB Box #6 Channel 82 (see diagram for reference)
- FRAME J REGULAR BRANCHES Pole Inserts labeled 83 and 83A**
 Place Smart T connector between both branches (83 is the First Branch to plug into vertical female closest to male connector on the smart "T" and 83A will plug into the horizontal female connector) Add cable extender (12' long) to Smart T and run down to NDB Box #6 Channel 83 (see diagram for reference)
- FRAME J REGULAR BRANCHES Pole Inserts labeled 84 and 84A**
 Place Smart T connector between both branches (84 is the First Branch to plug into vertical female closest to male connector on the smart "T" and 84A will plug into the horizontal female connector) Add cable extender (12' long) to Smart T and run down to NDB Box #6 Channel 84 (see diagram for reference)
- FRAME J REGULAR BRANCHES Pole Inserts labeled 85 and 85A**
 Place Smart T connector between both branches (85 is the First Branch to plug into vertical female closest to male connector on the smart "T" and 85A will plug into the horizontal female connector) Add cable extender (12' long) to Smart T and run down to NDB Box #6 Channel 85 (see diagram for reference)

CONTINUED ON NEXT PAGE ...

SEQUOIA TREES: RGB INSTALLATION

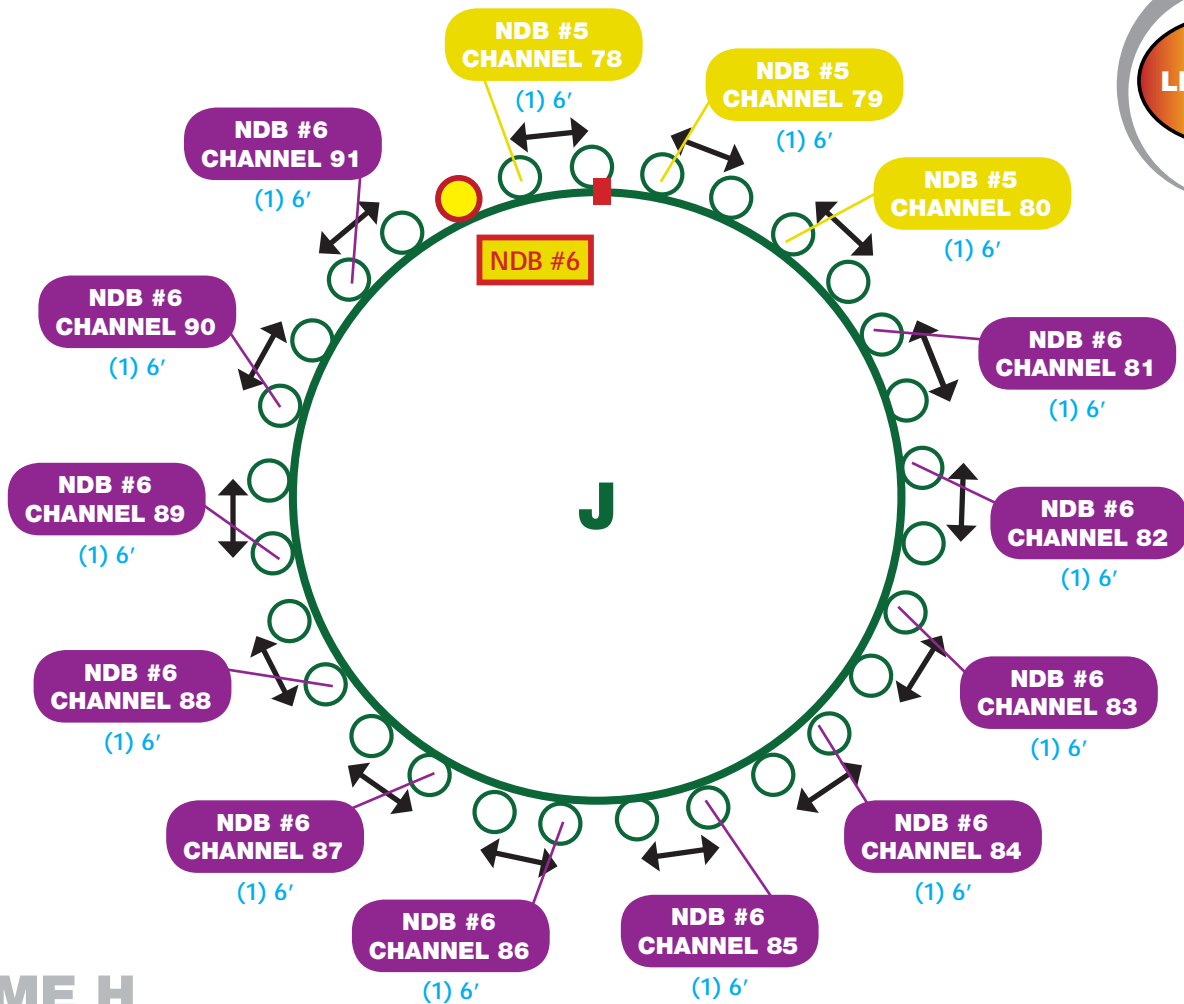

FRAME H

CONTINUED FROM PREVIOUS PAGE ...

- FRAME J REGULAR BRANCHES Pole Inserts labeled 86 and 86A**
 Place Smart T connector between both branches (86 is the First Branch to plug into vertical female closest to male connector on the smart "T" and 86A will plug into the horizontal female connector) Add cable extender (12'long) to Smart T and run down to NDB Box #6 Channel 86 (see diagram for reference)
- FRAME J REGULAR BRANCHES Pole Inserts labeled 87 and 87A**
 Place Smart T connector between both branches (87 is the First Branch to plug into vertical female closest to male connector on the smart "T" and 87A will plug into the horizontal female connector) Add cable extender (12'long) to Smart T and run down to NDB Box #6 Channel 87 (see diagram for reference)
- FRAME J REGULAR BRANCHES Pole Inserts labeled 88 and 88A**
 Place Smart T connector between both branches (88 is the First Branch to plug into vertical female closest to male connector on the smart "T" and 88A will plug into the horizontal female connector) Add cable extender (6'long) to Smart T and run down to NDB Box #6 Channel 88 (see diagram for reference)
- FRAME J REGULAR BRANCHES Pole Inserts labeled 89 and 89A**
 Place Smart T connector between both branches (89 is the First Branch to plug into vertical female closest to male connector on the smart "T" and 89A will plug into the horizontal female connector) Add cable extender (6'long) to Smart T and run down to NDB Box #6 Channel 89 (see diagram for reference)
- FRAME J REGULAR BRANCHES Pole Inserts labeled 90 and 90A**
 Place Smart T connector between both branches (90 is the First Branch to plug into vertical female closest to male connector on the smart "T" and 90A will plug into the horizontal female connector) Add cable extender (6'long) to Smart T and run down to NDB Box #6 Channel 90 (see diagram for reference)
- FRAME J REGULAR BRANCHES Pole Inserts labeled 91 and 91A**
 Place Smart T connector between both branches (91 is the First Branch to plug into vertical female closest to male connector on the smart "T" and 91A will plug into the horizontal female connector) Add cable extender (6'long) to Smart T and run down to NDB Box #6 Channel 91 (see diagram for reference)

After each row of branches is completed remember to fluff branches/ reset power on NDB boxes to test lights.