



**WARNING!** An authorised Our Dealer or qualified technician must perform the initial setup of this scooter and must perform all of the procedures in this manual.

The symbols below are used throughout this owner's manual and on the Travel Scooter to identify warnings and important information. It is very important for you to read them and understand them completely.



**WARNING!** Indicates a potentially hazardous condition/situation. Failure to follow designated procedures can cause either personal injury, component damage or malfunction. On the product, this icon is represented as a black symbol on a yellow triangle with a black border.



**MANDATORY!** These actions should be performed as specified. Failure to perform mandatory actions can cause personal injury and/or equipment damage. On the product, this icon is represented as a white symbol on a blue dot.



**PROHIBITED!** These actions are prohibited. These actions should not be performed at any time or in any circumstances. Performing a prohibited action can cause personal injury and/or equipment damage. On the product, this icon is represented as a black symbol with a red circle and a red slash.

Please fill out the following information for quick reference:

Dealer: _____
Address: _____
Phone Number: _____
Purchase Date: _____ Serial Number: _____

*NOTE: This owner's manual is compiled from the latest specifications and product information available at the time of publication. We reserve the right to make changes as they become necessary. Any changes to our products may cause slight variations between the illustrations and explanations in this manual and the product you have purchased. The latest/current version of this manual is available on our website.*

- I. INTRODUCTION.**
- II. SAFETY**
- III. YOUR TRAVEL SCOOTER**
- IV. BATTERIES AND CHARGING**
- V. OPERATION**
- VI. DISASSEMBLY AND ASSEMBLY**
- VII. BASIC TROUBLESHOOTING**
- VIII. CARE AND MAINTENANCE**
- IX. WARRANTY**
- APPENDIX I - SPECIFICATIONS**

## **SAFETY**

The product you have purchased combines state-of-the-art components with **safety**, comfort and styling in mind. We are confident the design features will provide you with the conveniences you expect during your daily activities. Understanding how to **safely** operate and care for this product should bring you years of trouble-free operation and service.

**Read and follow** all instructions, warnings and notes in this manual and all other accompanying literature before attempting to operate this product for the first time. In addition, your **safety** depends upon you, as well as your dealer, carer or healthcare professional in using good judgement.

**If there is any information in this manual which you do not understand or if you require additional assistance for setup or operation, please contact your authorised our Dealer. Failure to follow the instructions, warnings and notes in this manual and those located on your our product can result in personal injury or product damage and will void our product warranty.**

**PURCHASER'S AGREEMENT**  
By accepting delivery of this product, you promise that you will not change, alter or modify this product or remove or render inoperable or unsafe any guards, shields or other safety features of this product; fail, refuse or neglect to install any retrofit kits from time to time provided by our to enhance or preserve the safe use of this product.

## **SHIPPING AND DELIVERY**

Before using your Travel Scooter, make sure your delivery is complete as some components may be individually packaged. If you do not receive a complete delivery, please contact your authorised our Dealer immediately. Where damage has occurred during transport, either to the packaging or content, please contact the delivery company responsible.

## **INFORMATION EXCHANGE**

We want to hear your questions, comments and suggestions about this manual. We would also like to hear about the safety and reliability of your new Travel Scooter and about the service you received from your authorised our Dealer. Please notify us of any change of address, so we can keep you apprised of important information about safety, new products and new options that can increase your ability to use and enjoy your Travel Scooter. Please feel free to contact us at the address below.

TEL:

Address:

***NOTE: If you ever lose or misplace your product registration card or your copy of this manual, contact us and we will be glad to send you a new one immediately***

## PRODUCT SAFETY SYMBOLS

The symbols below are used on the Travel Scooter to identify warnings, mandatory actions and prohibited actions. It is very important for you to read and understand them completely.



**Pinch/Crush points created during assembly.**



**Corrosive chemicals contained in battery.**



**EMI-RFI - This product has been tested and passed at an immunity level of 20 V/m.**



**Do not lift the mobility vehicle while seated in it.**



**Do not lift the mobility vehicle while seated in it.**



**Explosive conditions exist!**



**Read and follow the information in the owner's manual.**



**Maximum weight capacity.**



**Unlocked and in freewheel mode.**

**Place unit on level ground and stand to one side when changing from drive mode to freewheel mode or freewheel mode to drive mode.**

**Locked and in drive mode.**



**Wear safety goggles.**



**Please use the original lithium battery or the model approved by the dealer.**



**Do not remove anti-tip wheels.**



**Avoid exposure to rain, snow, ice, salt or standing water whenever possible. Maintain and store in a clean and dry condition.**



**Removal of grounding prong can create electrical hazard. If necessary, properly install an approved 3-pronged adapter to an electrical outlet having 2-pronged plug access.**

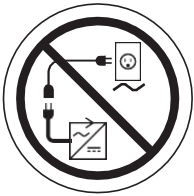

**Do not connect an extension lead to the AC/DC converter or the battery charger.**

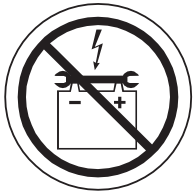

**Keep tools and other metal objects away from battery terminals. Contact with tools can cause electrical shock.**



**Do not use a cell phone, walkie/talkie, laptop or other radio transmitter while operating.**



**Do not allow unsupervised children to play near the Travel Scooter while the batteries are charging.**



**Keep your hands away from the tyres when driving. Be aware that loose fitting clothing can become caught in drive tyres.**

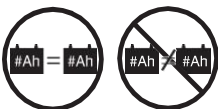

**Do not use batteries with different amp-hour (Ah) capacities. Do not mix old and new batteries.**



**Battery charger for indoor use only.**



**Disposal and recycling - Contact your authorised our Dealer for information on proper disposal and recycling of your our product and its packaging.**



**Contains Lead.**



**Do not place your Travel Scooter in freewheel mode while on a decline.**



**Do not place your Travel Scooter in freewheel mode while on an incline.**

## GENERAL



**MANDATORY! Do not operate your new Travel Scooter for the first time without completely reading and understanding this owner's manual.**

Your Travel Scooter is a state-of-the-art life-enhancement device designed to increase mobility.our provides an extensive variety of products to best fit the individual needs of the Travel Scooter user. Please be aware that the final selection and purchasing decision regarding the type of Travel Scooter to be used is the responsibility of the Travel Scooter user, who is capable of making such a decision, and his/her healthcare professional (i.e., medical doctor, physical therapist, etc.).

The contents of this manual are based on the expectation that a mobility device expert has properly fitted the Travel Scooter to the user and has assisted the prescribing healthcare professional and/or the authorised our Dealer in the instruction process for the use of the product.

There are certain situations, including some medical conditions, where the Travel Scooter user will need to practice operating the Travel Scooter in the presence of a trained attendant. A trained attendant can be defined as a family member or care professional specially trained in assisting a Travel Scooter user in various daily living activities.

As you begin using your Travel Scooter during daily activities, you will probably encounter situations in which you will need some practice. Simply take your time and you will soon be in full and confident control as you manoeuvre through doorways, on and off lifts, up and down ramps and over moderate terrain.

Below are some precautions, tips and other safety considerations that will help you become accustomed to operating the Travel Scooter safely.

## MODIFICATIONS

Our designed and engineered your Travel Scooter to provide maximum mobility and utility. However, under no circumstances should you modify, add, remove or disable any feature, part or function of your Travel Scooter.



**WARNING! Do not modify your Travel Scooter in any way not authorised by our. Do not use accessories if they have not been tested or approved for our products.**

## REMOVABLE PARTS



**WARNING! Do not attempt to lift or move your Travel Scooter by any of its removable parts, including the armrests, seat or shroud.**



## SAFETY CHECK

Get to know the feel of your Travel Scooter and its capabilities. Our recommends that you perform a safety check before each use to make sure your Travel Scooter operates smoothly and safely.

### Perform the following inspections prior to using your Travel Scooter:

- Check all electrical connections. Make sure they are tight and not corroded.
- Check the brakes (freewheel lever in drive mode).
- Check battery charge.

If you discover a problem, contact your authorised our dealer for assistance.

## WEIGHT LIMITATIONS

Your Travel Scooter is rated for a maximum weight capacity. Refer to the specifications table for this information.



**MANDATORY!** Stay within the specified weight capacity for your Travel Scooter. Exceeding the weight capacity voids your warranty. Our will not be held responsible for injuries and/or property damage resulting from failure to observe weight limitations.



**WARNING!** Do not carry passengers on your Travel Scooter. Carrying passengers on your Travel Scooter may affect the centre of gravity, resulting in a tip or a fall.

## INCLINE INFORMATION

More and more buildings have ramps with specified degrees of inclination, designed for easy and safe access. Some ramps may have turning switchbacks (180-degree turns) that require you to have good cornering skills on your TravelScooter.

- Proceed with extreme caution as you approach the downgrade of a ramp or other incline.
- Take wide swings with your Travel Scooter around any tight corners. If you do that, the Travel Scooter's rear wheels will follow a wide arc, not cut the corner short and not bump into or get hung up on any railing corners.
- When driving down a ramp, keep the Travel Scooter's speed adjustment set to the slowest speed setting to ensure a safely controlled descent.
- Avoid sudden stops and starts.

When climbing an incline, try to keep your Travel Scooter moving. If you must stop, start up again slowly and then accelerate cautiously. When driving down an incline, do so by setting the speed adjustment dial to the slowest setting and driving in the forward direction only. If your Travel Scooter starts to move down the incline faster than you anticipated or desired, allow it to come to a complete stop by releasing the throttle control lever. Then push the throttle control lever forward slightly to ensure a safely controlled descent.

**WARNING!** When climbing an incline, do not zigzag or drive at an angle up the face of the incline. Drive your Travel Scooter straight up the incline. This greatly reduces the possibility of a tip or a fall. Always exercise extreme caution when negotiating an incline.



**WARNING!** Do not drive your Travel Scooter across the side of an incline or diagonally up or down an incline; do not stop, if possible, while driving up or down an incline.

**WARNING!** You should not travel up or down a potentially hazardous incline (i.e., areas covered with snow, ice, cut grass or wet leaves).

**WARNING! When on any sort of an incline or decline, never place the Travel Scooter in freewheel mode, especially when seated on it or standing next to it.**



**WARNING! Even though your Travel Scooter is capable of climbing slopes greater than those illustrated in figure 1, do not, under any circumstances, exceed the incline guidelines or any other specifications presented in this manual. Doing so could cause instability in your Travel Scooter.**

Handicap public access ramps are not subject to government regulation in all countries and therefore do not necessarily share the same standard percent of slope. Other inclines may be natural or, if man-made, not designed specifically for Travel Scooters. **Figure 1** illustrates your Travel Scooter's stability and its ability to climb grades under various weight loads and under controlled testing conditions.

These tests were conducted with the Travel Scooter's seat in the highest position and adjusted rearward on the seat base to its farthest rearward position. Use this information as a guideline. Your Travel Scooter's ability to travel up inclines is affected by your weight, your Travel Scooter's speed, your angle of approach to the incline and your Travel Scooter setup.

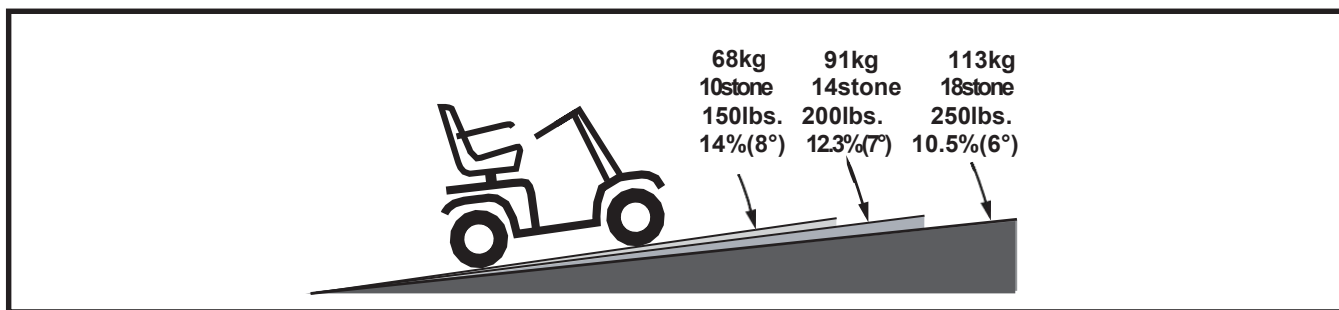

Figure 1. Maximum Recommended Incline Angles



**WARNING! Never carry an oxygen tank weighing more than 6.8 kg (15 lbs.). Never fill the front or rear basket with contents exceeding 6.8 kg (15 lbs.).**

**WARNING! Any attempt to climb or descend a slope steeper than what is shown in figure 1 may put your Travel Scooter in an unstable position and cause it to tip.**

When you approach an incline, it is best to lean forward. See **figures 2 and 2A**. This shifts the centre of gravity of you and your Travel Scooter toward the front of the Travel Scooter for improved stability.

**NOTE:** *When negotiating ramps, if the throttle control lever is released while moving forward, the powered Travel Scooter may “roll back” approximately 30.5 cm (12 in.) before the brake engages. If the throttle control lever is released while moving in reverse, the powered Travel Scooter may “roll back” approximately 1 metre (3 ft.) before the brake engages.*

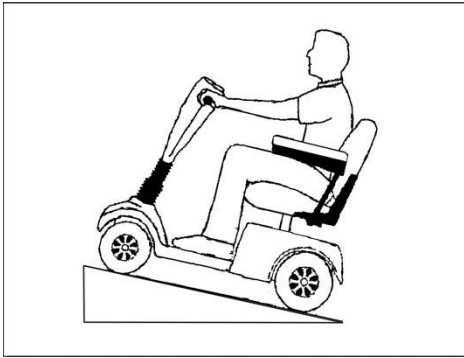

Figure 2. Normal Driving Position



Figure 2A. Increased Stability Driving Position

## CORNERING INFORMATION

Excessively high cornering speeds can create the possibility of tipping. Factors which affect the possibility of tipping include, but are not limited to, cornering speed, steering angle (how sharply you are turning), uneven road surfaces, inclined road surfaces, riding from an area of low traction to an area of high traction (such as passing from a grassy area to a paved area—especially at high speed while turning) and abrupt directional changes. High cornering speeds are not recommended. If you feel that you may tip over in a corner, reduce your speed and steering angle (i.e., lessen the sharpness of the turn) to prevent your Travel Scooter from tipping.



**WARNING! When cornering sharply, reduce your speed and maintain a stable centre of gravity. When using your Travel Scooter at higher speeds, do not corner sharply. This greatly reduces the possibility of a tip or fall. Always exercise common sense when cornering.**

## BRAKING INFORMATION

Your Travel Scooter is equipped with these powerful brake systems:

- Regenerative: Uses electricity to rapidly slow the vehicle when the throttle control lever returns to the centre/stop position.
- Disc Park Brake: Activates mechanically after regenerative braking slows the vehicle to near stop or when power is removed from the system for any reason.

## OUTDOOR DRIVING SURFACES

Your Travel Scooter is designed to provide optimum stability under normal driving conditions—dry, level surfaces composed of concrete, blacktop or tarmac. However, Our recognises that there will be times when you will encounter other surface types. For this reason, your Travel Scooter is designed to perform admirably on packed soil, grass and gravel. Feel free to use your Travel Scooter safely on lawns and in park areas.

- Reduce your Travel Scooter's speed when driving on uneven terrain and/or soft surfaces.
- Avoid tall grass that can become tangled in the running gear or wrapped around the axle.
- Avoid loosely packed gravel and sand.
- If you feel unsure about a driving surface, avoid that surface.

## PUBLIC STREETS AND ROADWAYS



**WARNING!** Exercise extreme caution when operating the Travel Scooter on footpaths, pavements, bridleways, pedestrian areas and roads. Obey all local pedestrian traffic rules.

## STATIONARY OBSTACLES (STEPS, KERBS, ETC.)

**WARNING!** Do not drive near raised surfaces, unprotected ledges and/or drop-offs (kerbs, porches, stairs, etc.).

**WARNING!** Do not attempt to have your Travel Scooter climb or descend an obstacle that is inordinately high.



**WARNING!** Do not attempt to have your Travel Scooter proceed rearward down any step, kerb or other obstacle. This may cause the Travel Scooter to tip.

**WARNING!** Be sure your Travel Scooter is traveling perpendicular to any kerb you may be required to ascend or descend. See figures 3 and 3A.

**WARNING!** Do not attempt to negotiate a kerb that has a height greater than 5 cm (2 in.).

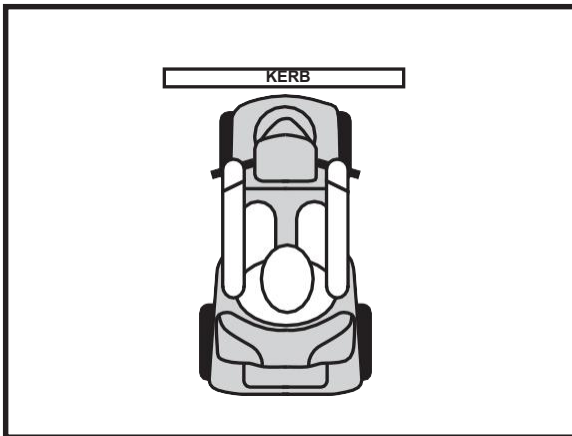

Figure 3. Correct Kerb Approach

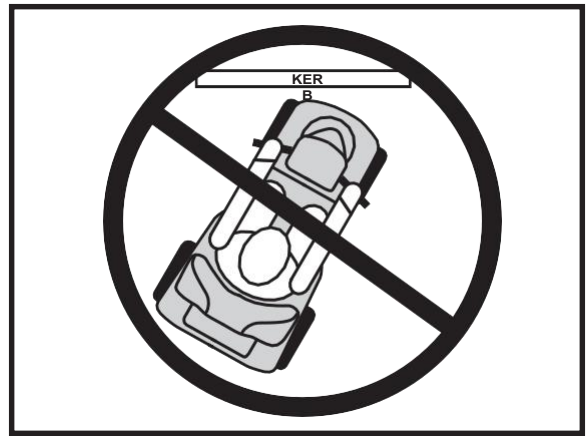

Figure 3A. Incorrect Kerb Approach

## INCLEMENT WEATHER PRECAUTIONS

Exposure of your Travel Scooter to inclement weather conditions should be avoided whenever possible. If suddenly caught up in rain, snow, severe cold or heat while operating your Travel Scooter, proceed to shelter at the earliest opportunity. Thoroughly dry your Travel Scooter before storing, charging or operating your Travel Scooter.



**PROHIBITED!** Operating in rain, snow, salt, mist/spray conditions and on icy/slippy surfaces can cause damage to the Travel Scooter and electrical system. Maintain and store your Travel Scooter in a dry and clean condition.



**WARNING!** Prolonged exposure to hot or cold conditions may affect the temperature of upholstered and non-upholstered items on the Travel Scooter, possibly resulting in skin irritation. Exercise caution when using your Travel Scooter in extremely hot or cold conditions or when exposing your Travel Scooter to direct sunlight for prolonged periods of time.

## **FREEWHEEL MODE**

Your Travel Scooter is equipped with a manual freewheel lever that, when pushed forward, allows the Travel Scooter to be pushed. For more information about how to place your Travel Scooter into and out of freewheel mode, see III. “Your Travel Scooter.”



**WARNING! When your scooter is in freewheel mode, the braking system is disengaged.**

- **Disengage the drive motors only on a level surface.**
- **Ensure the key is removed from the key switch.**
- **Stand to one side of the scooter to engage or disengage freewheel mode. Never sit on a scooter to do this.**
- **After you have finished pushing your scooter, always return it to the drive mode to lock the brakes.**

An added feature built into the Travel Scooter is “push-too-fast” protection, which safeguards the Travel Scooter against gaining excessive speed while in freewheel mode.

“Push-too-fast” operates differently depending on which of two conditions exists:

- If the key is turned to the “off” position while in freewheel mode, the Travel Scooter’s controller activates regenerative braking when the Travel Scooter is pushed faster than a maximum threshold which has been preprogrammed. In this case, the controller is acting as a speed governor.
- If the key is in the “on” position while in freewheel mode, you will encounter considerable resistance at any speed because the brakes are fully engaged. This prevents the Travel Scooter from gaining unwanted momentum should the manual freewheel lever inadvertently be released while driving the Travel Scooter.

## **STAIRS AND ESCALATORS**

Travel Scooters are not designed to travel up or down stairs or escalators. Always use a lift.



**WARNING! Do not use your Travel Scooter to negotiate steps or escalators.**

## **DOORS**

- Determine if the door opens toward or away from you.
- Use your hand to turn the knob or push the handle or push-bar.
- Drive your Travel Scooter gently and slowly forward to push the door open or drive your Travel Scooter gently and slowly rearwards to pull the door open.

## **LIFTS**

Modern lifts have a door edge safety mechanism that, when pushed, reopens the door(s).

- If you are in the doorway of a lift when the door(s) begin to close, push on the rubber door edge or allow the rubber door edge to contact the Travel Scooter and the door will reopen.
- Use care that handbags, packages or Travel Scooter accessories do not become caught in lift doors.

***NOTE: If your Travel Scooter’s turning radius is greater than 152.4 cm (60 in.), it may be difficult to manoeuvre in lifts and building entrances. Use caution when attempting to turn or manoeuvre your Travel Scooter in small spaces, and avoid areas that might pose a problem.***

## LIFT/ELEVATION PRODUCTS

If you will be traveling with your Travel Scooter, you may find it necessary to use a lift/elevation product to aid in transportation. We recommend that you closely review the instructions, specifications and safety information set forth by the manufacturer of the lift/elevation product before using that product.



**WARNING! Never sit on your Travel Scooter when it is being used in connection with any type of lift/elevation product. Your Travel Scooter was not designed with such use in mind and any damage or injury incurred from such use is not the responsibility of our.**

## BATTERIES

In addition to following the warnings below, be sure to comply with all other battery handling information.



**MANDATORY! Battery posts, terminals and related accessories contain lead and lead compounds. Wear goggles and gloves when handling batteries and wash hands after handling.**

**WARNING! Travel Scooter batteries are heavy. See specifications table. If you are unable to lift that much weight, be sure to get help. Use proper lifting techniques and avoid lifting beyond your capacity.**



**WARNING! Always protect the batteries from freezing and never charge a frozen battery. Charging a frozen battery may result in damage to the battery.**

**WARNING! Connect the battery harnesses in the proper manner. RED (+) cables must be connected to positive (+) battery terminals/posts. BLACK (-) cables must be connected to negative (-) battery terminals/posts. Protective caps should be installed over all battery terminals. REPLACE cables immediately if damaged.**

## BATTERY DISPOSAL AND RECYCLING

If you encounter a damaged or cracked battery, immediately enclose it in a plastic bag and contact your local waste disposal agency or your authorized Our Dealer for instructions on disposal and battery recycling, which is our recommended course of action.

## MOTOR VEHICLE TRANSPORT

We recommend that you do not remain seated in your Travel Scooter while traveling in a motor vehicle. The Travel Scooter should be stowed in the boot of a car or in the back of a truck or van with the batteries removed and properly secured. In addition, all removable Travel Scooter parts, including the armrests, seat and shroud should be removed and/or properly secured during motor vehicle transport.

**WARNING! Do not sit on your Travel Scooter while it is in a moving vehicle.**



**WARNING! Always be sure your Travel Scooter and its batteries are properly secured when it is being transported. Batteries should be secured in an upright position and protective caps should be installed on the battery terminals. Batteries should not be transported with any flammable or combustible items.**

## PREVENTING UNINTENDED MOVEMENT



**WARNING! If you anticipate being seated in a stationary position for an extended period of time, turn off the power. This will prevent unexpected motion from inadvertent throttle control lever contact.**



## GETTING ONTO AND OFF OF YOUR TRAVEL SCOOTER

Getting onto and off of your Travel Scooter requires a good sense of balance. Please observe the following safety tips when getting onto and off of your Travel Scooter:

- Remove the key from the key switch.
- Ensure that your Travel Scooter is not in freewheel mode. See III. “Your Travel Scooter.”
- Make certain that the seat is secured into place.

**WARNING! Position yourself as far back as possible in the Travel Scooter seat to prevent the Travel Scooter from tipping.**



**WARNING! Avoid putting all of your weight on the Travel Scooter armrests and do not use the armrests for weight bearing purposes, such as transfers. Such use may cause the Travel Scooter to tip, resulting in a fall from the Travel Scooter and personal injury.**

**WARNING! Avoid putting all of your weight on the floorboard. Such use may cause the Travel Scooter to tip.**

## REACHING AND BENDING

Avoid reaching or bending while driving your Travel Scooter. Bending forward creates the risk of accidental throttle control lever contact. Bending to the side while seated creates the risk of tipping. It is important to maintain a stable centre of gravity and keep the Travel Scooter from tipping. We recommend that the Travel Scooter user determine his/her personal limitations and practice bending and reaching in the presence of a qualified attendant.



**WARNING! Do not bend, lean or reach for objects if you have to pick them up from the Travel Scooter deck or from either side of the Travel Scooter. Movements such as these may change your centre of gravity and the weight distribution of the Travel Scooter and cause your Travel Scooter to tip.**



**PROHIBITED! Keep your hands away from the tyres when driving. Be aware that loose fitting clothing can become caught in drive tyres.**

## PRESCRIPTION DRUGS/PHYSICAL LIMITATIONS

The Travel Scooter user must exercise care and common sense when operating his/her Travel Scooter. This includes awareness of safety issues when taking prescribed or over-the-counter drugs or when the user has specific physical limitations.



**WARNING! Consult your physician if you are taking prescribed or over-the-counter medication or if you have certain physical limitations. Some medications and limitations may impair your ability to operate your Travel Scooter in a safe manner.**

## ALCOHOL/SMOKING

The Travel Scooter user must exercise care and common sense when operating his/her Travel Scooter. This includes awareness of safety issues while under the influence of alcohol or while smoking.

**WARNING! Do not operate your Travel Scooter while you are under the influence of alcohol, as this may impair your ability to drive safely.**



**WARNING! our strongly recommends that you do not smoke cigarettes while seated in your Travel Scooter, although the Travel Scooter has passed the necessary testing requirements for cigarette smoking. You must adhere to the following safety guidelines if you decide to smoke cigarettes while seated in your Travel Scooter.**

- **Do not leave lit cigarettes unattended.**
- **Keep ashtrays a safe distance from the seat cushions.**
- **Always make sure cigarettes are completely extinguished before disposal.**

## ELECTROMAGNETIC AND RADIO FREQUENCY INTERFERENCE (EMI/RFI)



**WARNING! Laboratory tests have shown that electromagnetic and radio frequency waves can have an adverse affect on the performance of electrically-powered mobility vehicles.**

Electromagnetic and Radio Frequency Interference can come from sources such as cellular phones, mobile two-way radios (such as walkie-talkies), radio stations, TV stations, amateur radio (HAM) transmitters, wireless computer links, microwave signals, paging transmitters and medium-range mobile transceivers used by emergency vehicles. In some cases, these waves can cause unintended movement or damage to the control system. Every electrically-powered mobility vehicle has an immunity (or resistance) to EMI. The higher the immunity level, the greater the protection against EMI. This product has been tested and has passed at an immunity level of 20 V/M.



**WARNING! Be aware that cell phones, two-way radios, laptops and other types of radio transmitters may cause unintended movement of your electrically-powered mobility vehicle due to EMI. Exercise caution when using any of these items while operating your mobility vehicle and avoid coming into close proximity of radio and TV stations.**



**WARNING! The addition of accessories or components to the electrically-powered mobility vehicle can increase the susceptibility of the vehicle to EMI. Do not modify your Travel Scooter in any way not authorised by our.**

**WARNING! The electrically-powered mobility vehicle itself can disturb the performance of other electrical devices located nearby, such as alarm systems.**

*NOTE: For more information on EMI/RFI, If unintended motion or brake release occurs, turn your Travel Scooter off as soon as it is safe to do so. Contact your authorised our Dealer to report the incident.*



## TILLER CONSOLE COMPONENTS

The tiller console houses all controls needed to drive your Travel Scooter, including the key switch, throttle control lever, horn button, speed adjustment dial and the battery condition meter. See figure 4.

Figure 4. Tiller Console

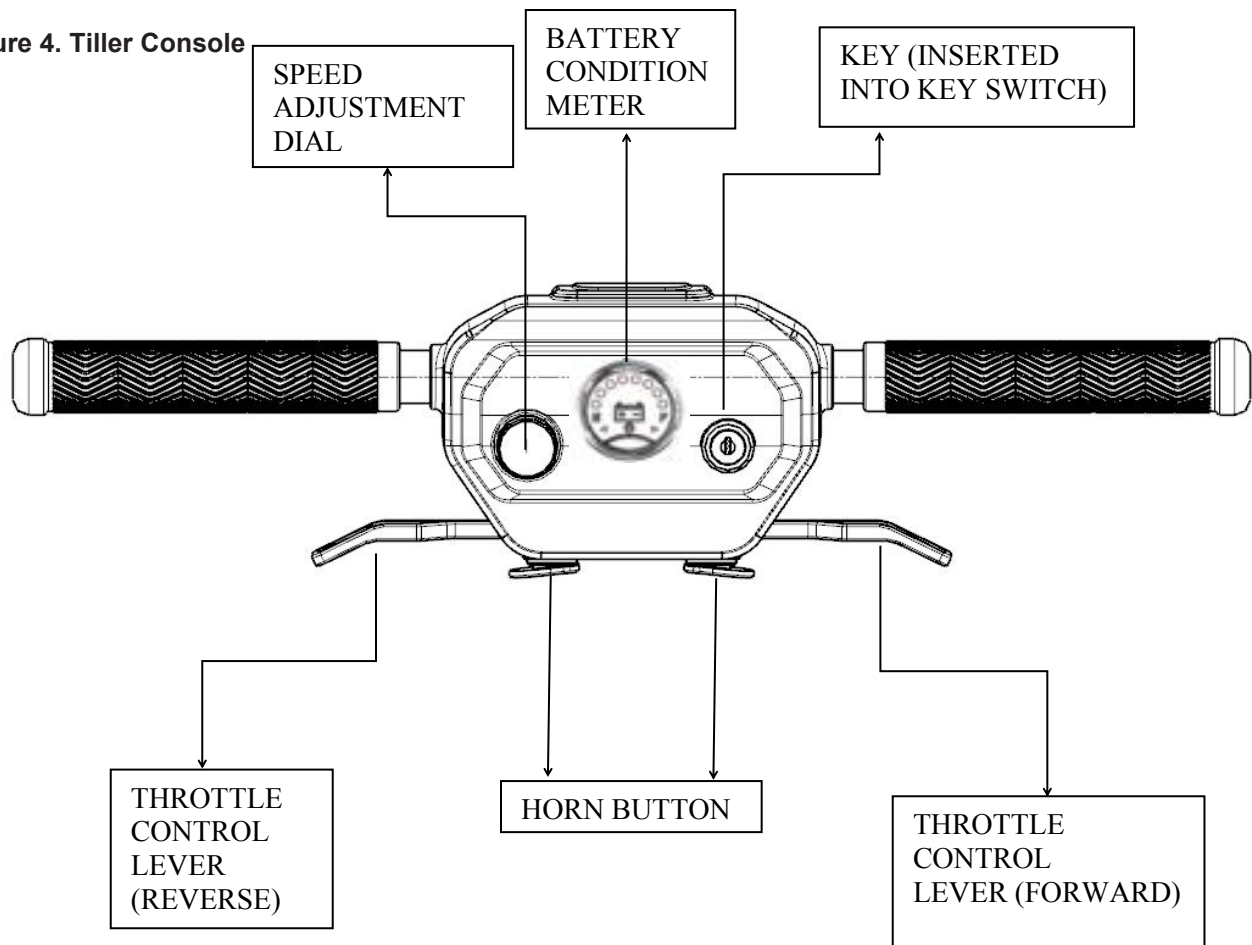

### Key Switch

- Insert the key into the key switch and turn it clockwise to power up (turn on) your Travel Scooter.
- Turn the key anticlockwise to power down (turn off) your Travel Scooter.

Although the key can be left in the key switch when the Travel Scooter is powered down, we recommend removing it to prevent unauthorised use of your Travel Scooter.



**WARNING! If the key is moved to the “off” position while your Travel Scooter is in motion, the electronic brakes will engage and your Travel Scooter will come to an abrupt stop!**

### Throttle Control Lever

This lever allows you to control the forward speed and the reverse speed of your Travel Scooter up to the maximum speed you preset with the speed adjustment dial.

- Place your right hand on the right handgrip and your left hand on the left handgrip.

- Use your right thumb to push the right side of the lever to disengage your Travel Scooter's brakes and move forward.
- Release the lever and allow your Travel Scooter to come to a complete stop before pushing the other side of the lever to move in reverse.

***NOTE: When the reverse side of the throttle control lever is engaged, a back-up beeper will sound.***

- When the throttle is completely released, it automatically returns to the centre "stop" position and engages your Travel Scooter's brakes.

## Horn Button

This button activates a warning horn. The Travel Scooter must be “on” for the horn to be operational. Do not hesitate to use the warning horn when doing so may prevent accident or injury.

## Battery Condition Meter

When the key is fully inserted into the key switch, this meter indicates approximate battery strength. For further information on the battery condition meter, see IV. “Batteries and Charging.”

## Speed Adjustment Dial

This dial allows you to preselect and limit your Travel Scooter’s top speed.

- The image of the fine Line represents the slowest speed setting.
- The image of the **thick lines** represents the fastest speed setting.

## REAR SECTION COMPONENTS

The manual freewheel lever, anti-tip wheels, motor/transaxle assembly and charging system components are located on the rear section of your Travel Scooter. **See figure.**

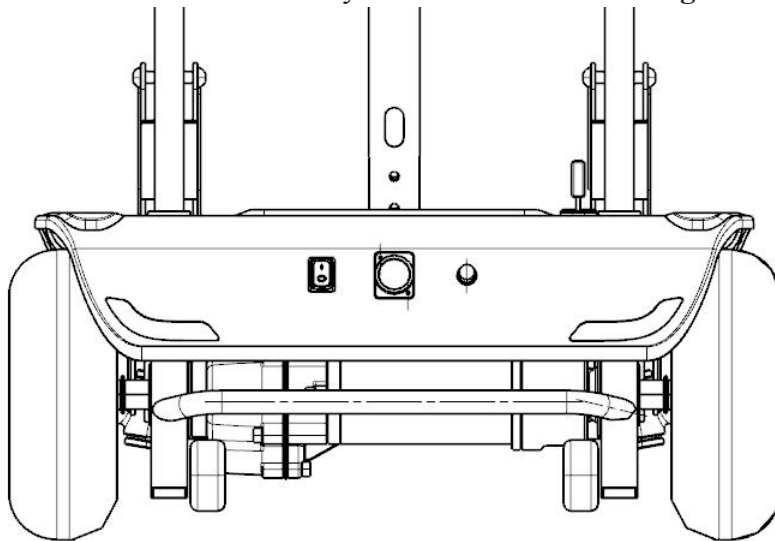

## Manual Freewheel Lever



**WARNING! Before placing your Travel Scooter into or taking it out of freewheel mode, remove the key from the key switch. Never sit on a Travel Scooter when it is in freewheel mode. Never put a Travel Scooter in freewheel mode on any incline.**

Whenever you need or want to push your Travel Scooter for short distances, you can put it in freewheel mode. The manual freewheel lever is located at the top right of the rear section.

1. Push forward on the manual freewheel lever to disable the drive system and the brake system. You may now push your Travel Scooter.
2. Push rearward on the manual freewheel lever to reengage the drive and the brake systems; this takes your Travel Scooter out of freewheel mode.

**WARNING! When your Travel Scooter is in freewheel mode, the braking system is**



**disengaged.**

- **Disengage the drive motors only on a level surface.**
- **Ensure the key is removed from the key switch.**
- **Stand to the side of the Travel Scooter to engage or disengage freewheel mode. Never sit on a Travel Scooter to do this.**
- **After you have finished pushing your Travel Scooter, always return it to the drive mode to lock the brakes.**

*NOTE: If the Travel Scooter is placed in freewheel mode (manual freewheel lever forward) while the key is in the “on” position, the Travel Scooter will not run until the manual freewheel lever is pushed rearward and the key is turned to the “off” position, then back to the “on” position.*

## Anti-Tip Wheels

The anti-tip wheels are an integral and important safety feature of your Travel Scooter. They are bolted to the frame at the rear of your Travel Scooter.



**PROHIBITED! Do not remove the anti-tip wheels or modify your Travel Scooter in any way that is not authorised by our.**

## Motor/Transaxle Assembly

The motor/transaxle assembly is an electromechanical unit that converts electrical energy from your Travel Scooter's batteries into the controlled mechanical energy that drives the Travel Scooter's wheels.

## Charger Power Lead Receptacle

The Travel Scooter's 3-pin off-board charger lead plugs into this receptacle. See figure :

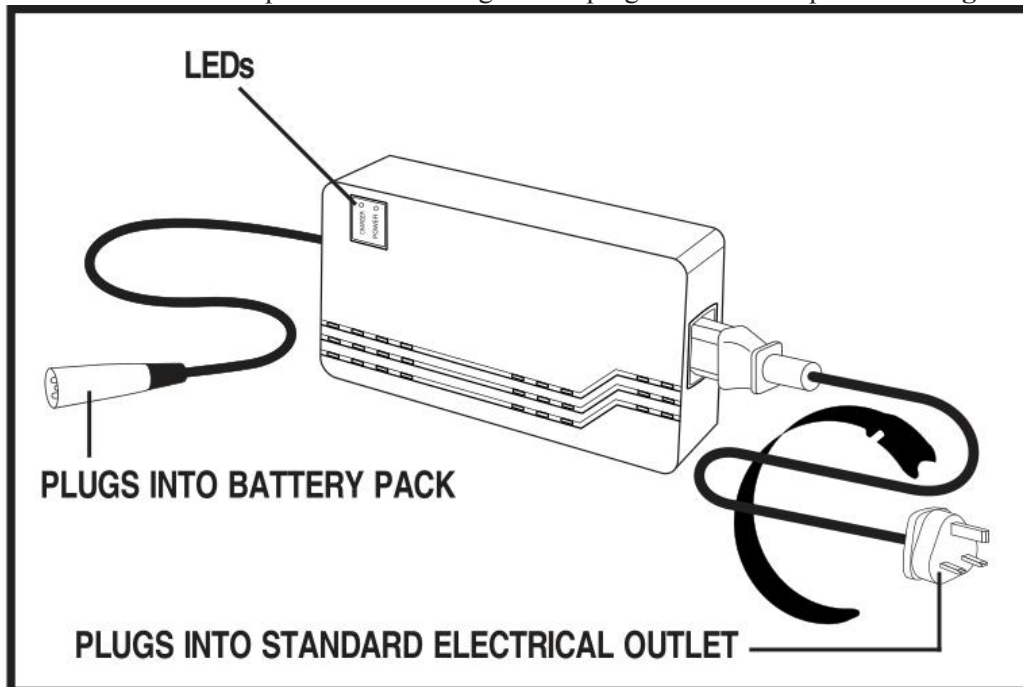

The off-board battery charger, when plugged into the charger power lead receptacle and a standard electrical outlet, charges the Travel Scooter's batteries. See figure.

The LED lights on the charger indicate different charger conditions at various times. Refer to the charger owner's manual enclosed with the charger for a complete explanation of these indicators.

## BATTERIES AND CHARGING

Your Travel Scooter is equipped with two sealed, maintenance free, 12 Ah batteries. Fully charge the batteries prior to using your Travel Scooter for the first time. Keeping the batteries fully charged will keep your Travel Scooter running smoothly.

### READING YOUR BATTERY VOLTAGE

The battery condition meter on the tiller console uses a colour code to indicate the approximate strength of your batteries. From right to left, green indicates fully charged batteries, yellow indicates a draining charge and red indicates that an immediate re-charge is necessary. See figure. To ensure the highest accuracy, the battery condition meter should be checked while operating your Travel Scooter at full speed on a dry, level surface.

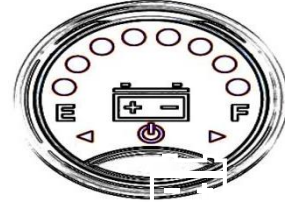

### CHARGING THE BATTERIES



**PROHIBITED!** Never use an extension lead to plug in your battery charger. Plug the charger directly into a properly wired standard electrical outlet.



**PROHIBITED!** Removal of the grounding prong can create an electrical hazard. If necessary, properly install an approved 3-pronged adapter to an electrical outlet having 2-pronged plug access.



**PROHIBITED!** Do not allow unsupervised children to play near the Travel Scooter while the batteries are charging. We recommend that you do not charge the batteries while the Travel Scooter is occupied.



**MANDATORY!** Read the battery charging instructions in this manual and in the manual supplied with the battery charger before charging the batteries.



**WARNING!** Explosive gases may be generated while charging the batteries. Keep the Travel Scooter and the battery charger away from sources of ignition such as flames or sparks and provide adequate ventilation when charging the batteries.

**WARNING!** You must recharge your Travel Scooter's batteries with the supplied off-board charger. Do not use an automotive-type battery charger.



**WARNING!** Inspect the battery charger, wiring and connectors for damage before each use. Contact your authorised our Dealer if damage is found.

**WARNING!** Do not attempt to open the battery charger case. If the battery charger does not appear to be working correctly, contact your authorised our Dealer.

**WARNING!** If the battery charger is equipped with cooling slots, then do not attempt to insert objects through these slots.



**WARNING!** If your battery charger has not been tested and approved for outdoor use, then do not expose it to adverse or extreme weather conditions. If the battery charger is exposed to adverse or extreme weather conditions, then it must be allowed to adjust to the difference in environmental conditions before use indoors. Refer to the manual supplied with the battery charger for more information.

Follow these easy steps to charge your batteries safely:

1. Position your Travel Scooter close to a standard electrical outlet. See figure
2. Remove the key from the key switch.
3. Make certain that the manual freewheel lever is in drive mode.
4. Remove the charger power lead receptacle cover from the charger power lead receptacle and plug the 3-pin off-board charger power lead into the receptacle.
5. Extend the charger power lead from the off-board battery charger and plug it into the electrical outlet. It is recommended that you charge your batteries for 8 to 14 hours.
6. When the batteries are fully charged, unplug the off-board charger power lead from the electrical outlet and then from the charger power lead receptacle.
7. Replace the charger power lead receptacle cover.

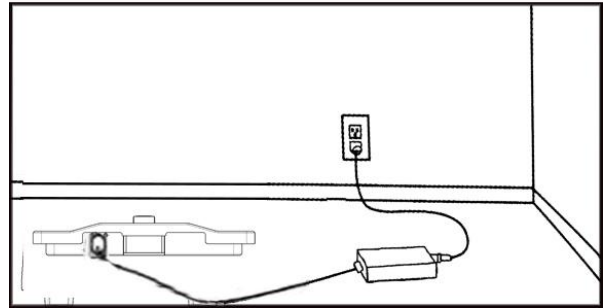

**NOTE:** There is a charger inhibit function on your Travel Scooter. The Travel Scooter will not run and the battery condition meter will not operate if the charger power lead is not disconnected from the Travel Scooter.

**NOTE:** For more information on battery charging, refer to the operation manual supplied with your battery charger.

## REPLACING THE TRAVEL SCOOTER'S BATTERIES

To ensure complete compatibility and optimal performance, our recommends using original equipment replacement batteries obtainable from your authorised our Dealer.



**MANDATORY!** Battery posts, terminals and related accessories contain lead and lead compounds. Wear goggles and gloves when handling batteries and wash hands after handling.



**WARNING!** Always use two batteries of the exact same type, chemistry and amp-hour (Ah) capacity. Refer to the specifications table in this manual and in the manual supplied with the battery charger for recommended type and capacities.

**WARNING!** Contact your authorised our Dealer if you have any questions regarding the batteries in your Travel Scooter.



**WARNING!** Do not replace the batteries while the Travel Scooter is occupied.

**WARNING!** The batteries on your Travel Scooter should only be serviced or replaced by an authorised our Dealer or a qualified technician.

**WARNING!** Do not mix old and new batteries. Always replace both batteries at the same time.

## **Battery Pack Removal**

1. Remove the key from the key switch.
2. Remove the seat by pulling it straight up and off of the TravelScooter.
3. Remove the battery compartment cover.
4. Disconnect the battery harnesses on the battery pack from the mating plugs on the Travel Scooter.
5. Lift the battery pack up and out of the battery compartment.



## **FREQUENTLY ASKED QUESTIONS**

### **How does the charger work?**

When your Travel Scooter's battery voltage is low, the charger works harder, sending more electrical current to the batteries to bring up their charge. As the voltage approaches full charge, the charger sends less and less electrical current to the batteries. When the batteries are fully charged, the current sent by the charger is at nearly zero amperage. Therefore, when the charger is plugged in, it maintains the charge on your Travel Scooter's batteries, but does not overcharge them. We do not recommend that you charge your Travel Scooter's batteries for more than 24 consecutive hours.

### **What if my Travel Scooter's batteries won't charge?**

Ensure that both ends of the charger power lead are inserted fully.

### **How often must I charge the batteries?**

Two major factors must be considered when deciding how often to charge your Travel Scooter's batteries:

- All day Travel Scooter use on a daily basis.
- Infrequent or sporadic Travel Scooter use.

With these considerations in mind, you can determine how often and for how long you should charge your Travel Scooter's batteries. We designed the off-board charger so that it will not overcharge your Travel Scooter's batteries. However, you may encounter some problems if you do not charge your batteries often enough and if you do not charge them on a regular basis. Following the guidelines below will provide safe and reliable battery operation and charging.

- If you use your Travel Scooter daily, charge its batteries as soon as you finish using it for the day. Your Travel Scooter will be ready each morning to give you a full day of service. We recommend that you charge your Travel Scooter's batteries for 8 to 14 hours after daily use.
- If you use your Travel Scooter once a week or less, charge its batteries at least once a week for 12 to 14 hours at a time.
- Keep your Travel Scooter's batteries fully charged.
- Avoid deeply discharging your Travel Scooter's batteries.
- Do not charge your Travel Scooter's batteries for more than 24 consecutive hours.

### **How can I get maximum range or distance per charge?**

Rarely will you have ideal driving conditions—smooth, flat, hard driving surfaces with no wind or curves. Often you will face hills, pavement cracks, uneven and loosely packed surfaces, curves and wind, all of which affect the distance or running time per battery charge. Below are a few suggestions for obtaining the maximum range per battery charge.

- Always fully charge your Travel Scooter's batteries prior to use.
- Plan your route ahead to avoid as many hills, cracked, broken or soft surfaces as possible.
- Limit your baggage weight to essential items.
- Try to maintain an even speed while your Travel Scooter is in motion.
- Avoid stop-and-go driving.

### **What type and size battery should I use?**

Your Travel Scooter comes equipped with two deep-cycle batteries that are sealed and maintenance free. Both AGM and Gel-Cell are deep-cycle batteries that are similar in performance. Do not use wet-cell batteries that have removable caps.



**WARNING! Corrosive chemicals are contained in batteries. Use only AGM or Gel-Cell batteries to reduce the risk of leakage or explosive conditions.**

### **Why do my new batteries seem weak?**

Deep-cycle batteries employ a different chemical technology than that used in car batteries, nickel-cadmium batteries (nicads) or in other common battery types. Deep-cycle batteries are specifically designed to provide power, drain down their charge and then accept a relatively quick recharge.

We work closely with our battery manufacturer to provide batteries that best suit your Travel Scooter's specific electrical demands. Fresh batteries arrive daily and are shipped fully charged with the Travel Scooter. During shipping, the batteries may encounter temperature extremes that may influence their initial performance. Heat diminishes the charge on the battery; cold slows the available power and extends the time needed to recharge the battery.



**WARNING! If your Travel Scooter's batteries become frozen, do not attempt to charge them. Cold or frozen batteries should be allowed to warm up for several days prior to recharging.**

It may take a few days for the temperature of your Travel Scooter's batteries to stabilise and adjust to their new room or ambient temperature. It takes a few charging cycles (partial draining followed by full recharging) to establish the critical chemical balance that is essential to a deep-cycle battery's peak performance and long life.

### **Follow these steps to properly break-in your Travel Scooter's new batteries for maximum efficiency and service life:**

1. Fully recharge any new battery prior to its initial use. This charging cycle brings the battery up to about 88% of its peak performance level.
2. Operate your new Travel Scooter in familiar and safe areas. Drive slowly at first and do not travel too far from your home or familiar surroundings until you have become accustomed to your Travel Scooter's controls.
3. Fully recharge the batteries. They should be at over 90% of their peak performance level.
4. Operate your Travel Scooter again.
5. Fully recharge the batteries again.
6. After four or five charging cycles, the batteries are able to receive a charge of 100% of their peak performance level and are able to last for an extended period of time.

### **How can I ensure maximum battery life?**

Fully charged deep-cycle batteries provide reliable performance and extended battery life. Keep your Travel Scooter's batteries fully charged whenever possible. Protect your Travel Scooter and batteries from extreme heat or cold. Batteries that are regularly and deeply discharged, infrequently charged, stored in extreme temperatures or stored without a full charge may be permanently damaged, causing unreliable performance and limited service life.

### **What about public transportation?**

If you intend to use public transportation with your Travel Scooter, you must contact the transportation provider in advance to determine their specific requirements.



## **BEFORE GETTING ON YOUR TRAVELSCOOTER**

- Have you fully charged the batteries? See IV. “Batteries and Charging.”
- Is the manual freewheel lever in the drive (rearward) position? Never leave the manual freewheel lever pushed forward unless you are manually pushing your Travel Scooter.
- Is the tiller lock knob in the unlocked position? See figures 6 and 6A.

## **GETTING ONTO YOUR TRAVEL SCOOTER**

1. Make certain that the key is removed from the key switch.



**WARNING! Never attempt to get onto or off of your Travel Scooter without first removing the key from the key switch. This will prevent the Travel Scooter from moving if accidental throttle control lever contact is made.**

2. Disengage the seat rotation lever and rotate the seat so it faces you.
3. Position yourself comfortably and securely in the seat and rotate the seat forward.
4. Make certain that the seat is fixed securely in position.
5. Make certain that your feet are safely on the floorboard.

## **ADJUSTMENTS AND CHECKS**

- Are you positioned comfortably in the seat?
- Is the seat at the proper height?
- Is the seat securely in place?
- Is the tiller at a comfortable driving position and locked securely in place?
- Is the tiller lock knob in the unlocked position?
- Is the key in the “on” position? See III. “Your Travel Scooter.”
- Does the Travel Scooter’s horn work properly?
- Is your proposed path clear of people, pets and obstacles?
- Have you planned your route to avoid adverse terrain and as many inclines as possible?

## **OPERATING YOUR TRAVEL SCOOTER**



**WARNING! The following can adversely affect steering and stability while operating your Travel Scooter:**

- **Holding onto or attaching a leash to walk your pet.**
- **Carrying passengers (including pets).**
- **Hanging any article from the tiller.**
- **Towing or being pushed by another motorised vehicle.**

Keep both hands on the tiller and your feet on the floorboard at all times while operating your Travel Scooter. This driving position gives you the most control over your vehicle.

- Set the speed adjustment dial to your desired speed.
- Press your thumb against the appropriate side of the throttle control lever.
- The electromechanical disc park brake automatically disengages and the Travel Scooter accelerates smoothly to the speed you preselected with the speed adjustment dial.
- Pull on the left handgrip to steer your Travel Scooter to the left.
- Pull on the right handgrip to steer your Travel Scooter to the right.
- Move the tiller to the centre position to drive straight ahead.

- Release the throttle control lever to decelerate and come to a complete stop.
- The electromechanical disc park brake automatically engages when your Travel Scooter comes to a stop.

***NOTE: Your Travel Scooter's reverse speed is slower than that of the forward speed you preset with the speed adjustment dial.***

### **GETTING OFF OF YOUR TRAVELSCOOTER**

1. Bring your Travel Scooter to a complete stop.
2. Remove the key from the key switch.
3. Rotate the seat to either side of the Travel Scooter and carefully and safely get out of the seat.

### **POWER DOWN TIMER FEATURE**

Your Travel Scooter is equipped with an energy saving automatic power down timer feature designed to preserve your Travel Scooter's battery life. If you mistakenly leave the key in the "on" position but do not use your Travel Scooter for approximately 20 minutes, the Travel Scooter's controller shuts down automatically.

If the power down timer feature takes effect, perform the following steps to resume normal operation.

1. Remove the key from the key switch.
2. Insert the key back into the key switch.

If you experience any problems with your Travel Scooter that you are not able to solve, contact your authorised our Dealer for information on maintenance and service.

Any electromechanical device requires occasional troubleshooting. However, most problems that arise can usually be solved with a bit of thought and common sense. Many of these problems occur because the batteries are not fully charged or because the batteries are worn down and can no longer hold a charge.

### **DIAGNOSTIC BEEP CODES**

The diagnostic beep codes for your Travel Scooter are designed to help you perform basic troubleshooting quickly and easily. A diagnostic beep code will sound in the event one of the conditions listed below develops.

***NOTE: Your Travel Scooter will not run unless the beep code condition is resolved and the Travel Scooter has been turned off, then turned back on.***

Flash	Description	Meaning
1	Battery Low	The batteries are running low. • Recharge the batteries.
2	Motor Voltage Fault	The motor or its associated wiring is faulty. ·check the motor and associated connections and wiring.
3	External signal interference	
4	untapped	
5	untapped	
6	Controller cannot drive	May be charging
7	Speed Pot Fault The throttle,	speed limit pot, SRW or their associated wiring may be faulty. ·Check the throttle and speed pot and _associated connections and wiring.
8	Controller internal fault	8 Motor Voltage Fault The motor or its associated wiring is faulty. ° check the motor and associated connections and wiring.
8	Controller internal fault	Check whether the controller is flooded
9	Park Brake Fault	Either a park brake release switch is active or the park brake is faulty. ·Check the park broke and associated connections and wiring. ·Ensure any associated switches are in their correct positions.
10	The battery voltage is too high.	Check whether the charger voltage meets the requirements

**What if the motor runs, but my Travel Scooter does not move?**

- Your Travel Scooter was probably left in freewheel mode.
- When the manual freewheel lever is pushed forward, the brakes are disengaged and all power to the motor/transaxle is cut.
- Pull the manual freewheel lever rearward to restore normal operation to your Travel Scooter.

**What if the main circuit breaker trips repeatedly?**

- Charge the Travel Scooter's batteries more frequently. See IV. "Batteries and Charging."
- See IV. "Batteries and Charging" or "Appendix I - Specifications" for information about your Travel Scooter's battery type.
- If the main circuit breaker trips repeatedly, contact your authorised our Dealer for service.

**What if the battery condition meter dips way down and the motor surges or hesitates when I press the throttle control lever?**

- Fully charge your Travel Scooter's batteries. See IV. "Batteries and Charging."
- Have your authorised our Dealer load test each batter





**What if all the systems on my Travel Scooter seem to be “dead”?**

- Make certain that the key is in the “on” position.
- Check that the batteries are fully charged. See IV. “Batteries and Charging.”
- Push in the main circuit breaker reset button. See III. “Your Travel Scooter.”
- Be sure the power down timer feature has not been activated.
- If having changed a battery recently, ensure that all of the battery connections are secure.

Your Travel Scooter requires a minimal amount of care and maintenance. If you do not feel confident in your ability to perform the maintenance listed below, you may schedule inspection and/or care and maintenance with your authorised our Dealer. The following areas require periodic inspection and/or care and maintenance.

## **TYRE CONDITION AND TREAD WEAR**

- Regularly inspect your Travel Scooter's tyres for signs of wear.
- Use a rubber conditioner on your Travel Scooter's tyre sidewalls to help preserve them.



**WARNING! Do not apply rubber conditioner on tyre tread; this may cause the tyres to become dangerously slippery.**

## **WHEEL REPLACEMENT**

If your Travel Scooter is equipped with a solid tyre insert, the entire wheel must be replaced. Contact your authorised our Dealer for information regarding replacement wheels for your Travel Scooter.



**WARNING! Wheels on your Travel Scooter should only be serviced/replaced by an authorised our Dealer or qualified technician.**

## **NYLON LOCK NUT REPLACEMENT**

Any nylon insert lock nut removed during the periodic maintenance, assembly or disassembly of the Travel Scooter must be replaced with a new nut. Nylon insert lock nuts should not be reused as it may cause damage to the nylon insert, resulting in a less secure fit. Replacement nylon insert lock nuts are available at local hardware stores or through your authorised our Dealer.

## **EXTERIOR SURFACES**

- Bumpers and trim benefit from an occasional application of rubber or vinyl conditioner.



**WARNING! Do not apply a rubber or vinyl conditioner on a Travel Scooter's vinyl seat or floorboard mats; they will become dangerously slippery.**

- The Travel Scooter shroud is made from durable ABS plastic and coated with an advanced formula urethane paint. A light application of car wax will help the shroud retain its high gloss.

## **CLEANING AND DISINFECTION**

- Use a damp cloth and mild, non-abrasive cleanser to clean the plastic and metal parts of your Travel Scooter. Avoid using products that may scratch the surface of your Travel Scooter.
- If necessary, clean your product with an approved disinfectant. Make sure the disinfectant is safe for use on your product before application.



**WARNING! Follow all safety instructions for the proper use of the disinfectant and/or cleaning agent before applying it to your product. Failure to comply may result in skin irritation or premature deterioration of upholstery and/or Travel Scooter finishes.**

## **BATTERY TERMINAL CONNECTIONS**

- Make certain that the terminal connections remain tight and uncorroded.
- The batteries must sit flat in the battery well.

## **AXLE BEARINGS AND THE MOTOR/TRANSAXLE ASSEMBLY**

These items are all prelubricated, sealed and require no subsequent lubrication.

## **CONSOLE, CHARGER AND ELECTRONICS**

- Keep these areas free of moisture.
- If any of these items do become exposed to moisture, let them dry thoroughly before operating your Travel Scooter again.

## **WIRING HARNESSES**

- Regularly check all wiring connections.
- Regularly check all wiring insulation, including the charger power lead, for wear or damage.
- Have your authorised our Dealer repair or replace any damaged connector, connection or insulation that you find before using your Travel Scooter again.



**PROHIBITED!** Even though the Travel Scooter has passed the necessary testing requirements for ingress of liquids, you should keep electrical connections away from sources of dampness, including direct exposure to water or bodily fluids and incontinence. Check electrical components frequently for signs of corrosion and replace as necessary.

## **STORAGE**

If you plan on not using your Travel Scooter for an extended period of time, it is best to:

- Fully charge its batteries prior to storage.
- Store your Travel Scooter in a warm, dry environment.
- Avoid storing your Travel Scooter where it will be exposed to temperature extremes.



**WARNING!** Always protect batteries from freezing temperatures and never charge a frozen battery. Charging a frozen battery can result in damage to the battery.

Batteries that are regularly and deeply discharged, infrequently charged, stored in extreme temperatures or stored without a full charge may be permanently damaged, causing unreliable performance and limited service life. It is recommended that you charge the Travel Scooter batteries periodically throughout periods of prolonged storage to ensure proper performance.

You may wish to place several boards under the frame of your Travel Scooter to raise it off of the ground during periods of prolonged storage. This takes the weight off the tyres and reduces the possibility of flat spots developing on the areas of the tyres contacting the ground.

## **DISPOSAL OF YOUR SCOOTER**

Your Travel Scooter must be disposed of according to applicable local and national statutory regulations. Contact your local waste disposal agency or authorised our Dealer for information on proper disposal of packaging, metal frame components, plastic components, electronics and batteries.

## **LIFETIME WARRANTY**

Structural frame components, including: platform, fork, seat post and frame welds.

## **TWO-YEAR LIMITED WARRANTY**

Drivetrain, including: transaxle, motor and brake.

## **ONE-YEAR LIMITED WARRANTY**

All electrical parts, including controllers and battery chargers, are covered for one year under warranty. Any attempt to open or dismantle these parts will lead to this warranty being void.

## **BATTERIES**

Batteries are covered by a twelve-month warranty from the original manufacturer.

## **NOT COVERED UNDER WARRANTY**

The following are classed as wear items, which may, under normal wear and tear, require replacing. These items are not therefore covered under warranty: tyres, lap belts, bulbs, upholstery, plastic shrouds, motor brushes and fuses. Warranty will also be refused if damage is deemed to have been caused through misuse or accident for which our Mobility Products Ltd. cannot be deemed responsible.

*NOTE: our Mobility Products Ltd. provides parts only under warranty. Your our Dealer is responsible for labour and service. Please contact your our Dealer for information about these services and for any applicable charges.*

n type, battery amp-hour (Ah), battery

Model Number	BC-MS211-FAF
Maximum Safe Slope	10°
Maximum Climbing Ability	12°
Maximum Obstacle Climbing Ability	5 cm (2 in.)
Overall Length <sup>2</sup>	102CM
Overall Width <sup>2</sup>	51CM
Turning Radius <sup>2</sup>	≤140CM
Speed (Maximum)	Variable up to 8.0 km/h
Range Per Charge <sup>1</sup>	Up to 7.5km with 5Ah batteries ,Up to 15km with 10Ah batteries
Ground Clearance <sup>2</sup>	8 cm
Weight Capacity	110 kg
Standard Seating	Type: Foldable vinyl covered moulded foam Material: Black Vinyl Dimensions: 44cm width 38 cm depth 41 cm height
Drive System	Rear-wheel drive, sealed mini transaxle, 24 volt DC motor
Braking System	Electronic, regenerative and electromechanical
Tyres	Type: solid Size: front: 2*8IN rear: 2*8IN
Battery Charger	2-amp off-board battery charger

<sup>1</sup>Varies with user weight, terrain type, battery amp-hour (Ah), battery charge, battery condition and tyre condition. This specification can be subject to a variance of (+ or – ) 10%.

<sup>2</sup> Due to manufacturing tolerances and continual product improvement, this specification can be subject to a variance of (+ or – ) 3%.

<sup>3</sup>TIANNEN or Gel-Cell type required.

**NOTE: All specifications subject to change without notice.**