

FIREFLY™



Electric Wheelchair Attachment Firefly™ 2.5 User Manual

Ver 1.4.4 04/11/2023

Phone: 415-552-6277

Email: sales@riomobility.com

Website: www.riomobility.com

IMPORTANT!

Consult with your health care professional to determine if the Firefly™2.5 is appropriate for you.

FOLLOW THE RECOMMENDATIONS IN YOUR WHEELCHAIR USER MANUAL.

DO NOT OPERATE THIS EQUIPMENT WITHOUT FIRST READING AND UNDERSTANDING THIS MANUAL. IT IS RECOMMENDED THAT INITIAL SETUP OF THIS HANDCYCLE BE PERFORMED BY A QUALIFIED TECHNICIAN, SUCH AS A WHEELCHAIR OR BICYCLE MECHANIC. TO OPTIMIZE SETUP IT IS SUGGESTED THE CUSTOMER BE SEATED IN THE WHEELCHAIR DURING INITIAL INSTALLATION.

AS WITH ANY THREE-WHEELED VEHICLE, SIDE-TO-SIDE STABILITY IS DECREASED COMPARED TO A WHEELCHAIR ALONE, SO USE CAUTION WHEN TURNING.

The Firefly™ 2.5 is intended for general recreational use only and is not intended as an exclusive means of mobility nor is intended for use in competition. The operation of an electric wheelchair attachment involves a certain level of risk and the potential for serious bodily injury. Follow local vehicle and wheelchair regulations.

Keep fingers and hands away from moving parts of the Firefly™ 2.5.

Children and young adults under the age of 18 years should not be left unattended while using the Firefly™ 2.5.

Do not carry anything that obstructs your view ahead or interferes with the operation of the controls on the handlebar.

Do not carry any additional weight on the frame (objects or people).

RIO MOBILITY IS NOT RESPONSIBLE FOR ANY DAMAGE OR INJURY DUE TO MISUSE OF YOUR WHEELCHAIR ATTACHMENT.

1. Wheelchair Requirements

The Firefly™ 2.5 fits most wheelchairs, but our mounting clamps will not fit onto some wheelchairs. Consider these five items to determine whether your wheelchair is compatible with the Firefly™ 2.5:

1) **Seat width:** Must be between 9 and 23 inches (23 to 58 cm).

(measured center-to-center between the vertical tubes where the mounting clamps are installed)

2) **Tube diameter:** Currently supported wheelchair tube diameters are:

(measured where the mounting clamps are installed)

- 7/8 inch (22.2 mm)
- 1 inch (25.4 mm)
- 1.125 inches (28.6 mm)
- 1.2 inches (30.5 mm)
- 1.25 inches (31.8 mm)

3) **Tube clearance:** To attach the mounting clamps, 1.25 inches (32 mm) of vertical clearance along the wheelchair tube is needed. Two inches of clearance extending horizontally both outward to the sides and towards the rear of the wheelchair is also needed, from the point on the wheelchair tube where the mounting clamps are installed. Diagrams of tube clearances are shown on the next page.

4) **Tube angle:** Ideally the wheelchair tubes should be vertical or close to vertical. Installation can be done on tubes that taper as well, however, the larger the taper angle the more challenging it is to attach and remove the Firefly™ 2.5 from the wheelchair. Diagrams on the next page show where the mounting clamps on wheelchairs with tapering tube angles should be installed.

5) **Footrests on folding chairs:** Folding or removable footrests can interfere with our mounting clamps.

Diagrams on the next page show examples of wheelchairs with non-rigid footrests. Never mount our clamps directly onto removable footrests as they were not designed to withstand such riding forces.

Anti-Tips & Seatbelts	When seated in the wheelchair, your center of gravity must be far enough forward to make “wheelies” or tipping backwards difficult. IMPORTANT: If the chair is set up such that “wheelies” are easy, it may be unstable while attaching or removing the Firefly™2.5. Anti-tips MUST be installed on your wheelchair. A seat belt is also strongly recommended.
Wheel Locks	Wheelchairs must have wheel locks installed.
Weight	Combined wheelchair and user weight must be less than 130kg/280lb.

printable ruler - wrap around wheelchair tube to measure tube diameter

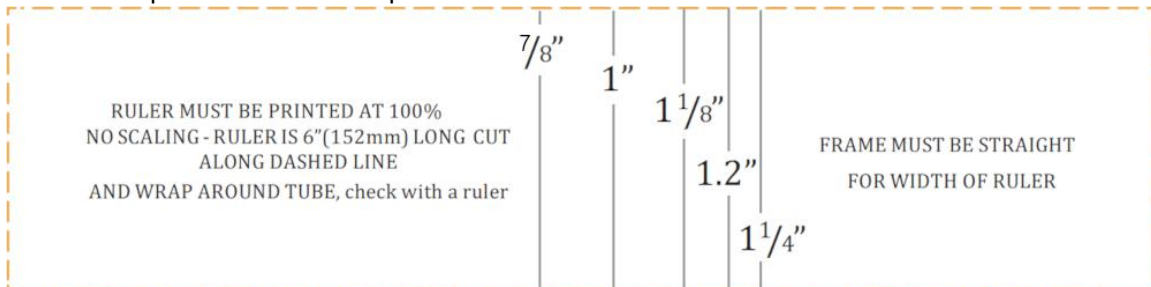

All our devices require 1.25 inches (32 mm) of vertical clearance on the wheelchair tubes where the mounting clamps are installed. The mounting clamps should be installed about 2/3 of the distance from the floor to the wheelchair seat. The mounting clamps also require two inches (50 mm) of horizontal clearance from the wheelchair tubes extending outward away from the sides of the wheelchair and two inches (50 mm) of horizontal clearance extending backward toward the rear of the wheelchair.

Compatibility Guide for Rigid Wheelchairs

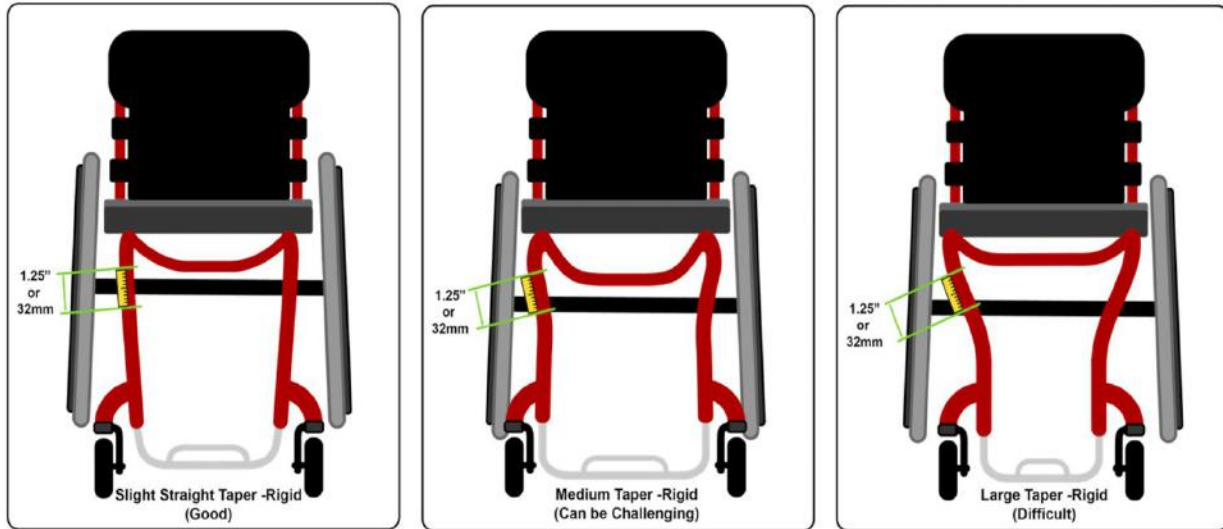

Compatibility Guide for Folding Wheelchairs

Ideally the mounting clamps should be installed above where the folding or removable footrests attach.

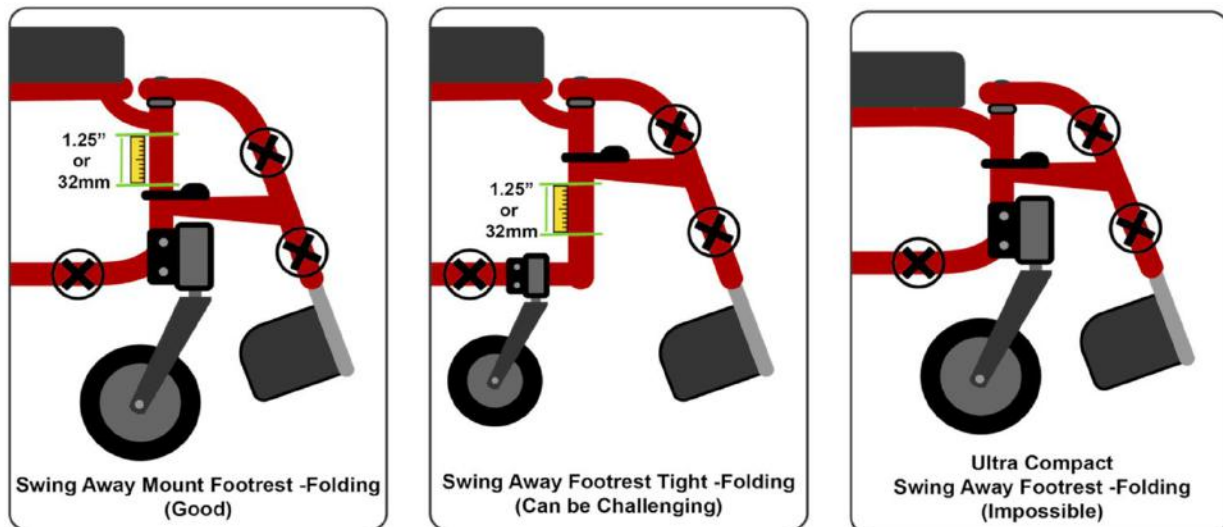

2. Components of the Firefly™ 2.5

Visit our website for the Firefly™ 2.5 installation video: www.riomobility.com

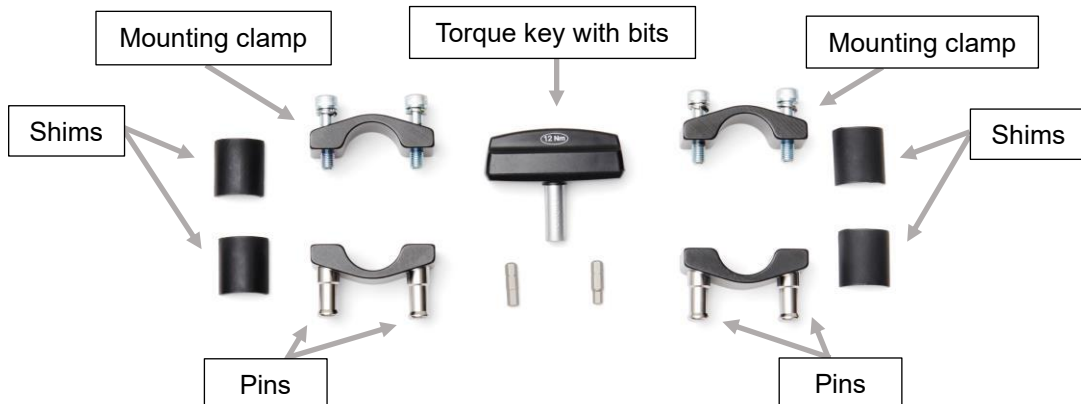

3. Installing the Firefly

Place foam blocks

Place the black foam blocks under the wheelchair's caster wheels while the wheelchair's parking brake is on. A wooden block or stacks of hardcover books two inches in height can be used in place of the foam blocks. Installation must be done with the caster wheels raised off the floor to provide safe clearance while using the Firefly.

Install mounting clamps

The Firefly attaches to the wheelchair using two mounting clamps installed onto the wheelchair's vertical tubes. Each clamp is secured using two horizontal pins, onto which the Firefly attaches using coupler plates. Attach the mounting clamps onto the vertical tubes of the wheelchair using the shims that provide the best fit between the clamp and the wheelchair tube. The clamps should be placed roughly 2/3 of the distance up from the floor to the wheelchair seat, on a straight section of tubing. Shims of four different thicknesses are provided to account for various diameter tubes, ranging from 7/8 in (22.2 mm) to 1.25 in (31.8 mm). The shims must sit flush onto the wheelchair tubes, and the clamps must sit flush onto the shims. Make sure the pins are facing outwards, away from the wheelchair. The clamps must not obstruct the wheelchair's parking brakes.

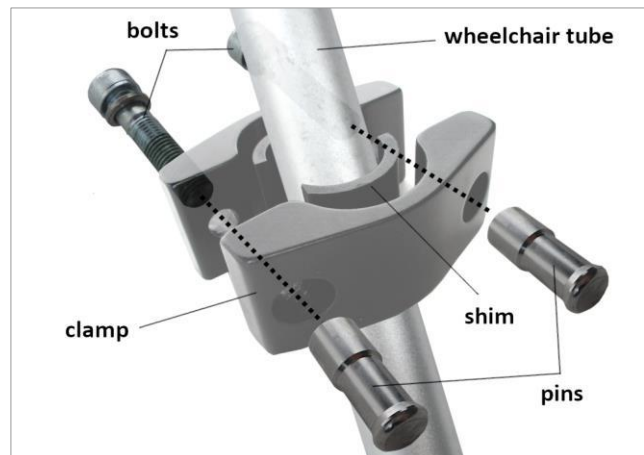

Level mounting clamps

Make sure the mounting clamps are level with each other by placing a long level on top of the two clamps. If you don't have a level that spans the distance between the two clamps, place a broom stick or other rigid object on top of the two clamps, with a short level or mobile phone with a level app on top.



Align mounting clamps

Place a long level or other rigid object against the front surface of the two clamps. Rotate the mounting clamps so that they sit flat against the flat surface of the level or rigid object. This ensures that the pins of both mounting clamps extend exactly perpendicular away from the wheelchair.

Tighten mounting clamps

Tighten the mounting clamps evenly using the supplied torque T-handle with six-millimeter hex bit. Twist the torque handle clockwise until you hear a “click” sound and feel the torque handle release pressure. Make sure to use the torque handle to tighten all four mounting clamp bolts.

Adjust U-bar

Next adjust the U-bar with coupler plates to fit the wheelchair. The U-bar consists of five tubes which can be slid and rotated relative to each other to change its width, length, and angle relative to the wheelchair. For initial installation, the tightness of the clamps should be adjusted so that the tubes can all rotate relative to each other but are also able to hold up their own weight. Not too tight, not too loose. First rotate the coupler tubes so that the coupler plates are facing inwards towards the wheelchair and the Firefly logo on the coupler tubes is facing up and outward away from the wheelchair.

The U-bar can be adjusted to fit on wheelchairs with tubes as little as 9 inches apart or as much as 23 inches apart (measured center-to-center between the tubes, where mounting clamps are installed). To adjust the U-bar to fit wheelchairs with tubes less than 15 inches apart, flip the L-tubes around. To do this, remove the coupler tube, pull the L-tube out, flip it around, and re-assemble. You can remove some of the padding on the corners of the L-tubes to make the U-bar even narrower.

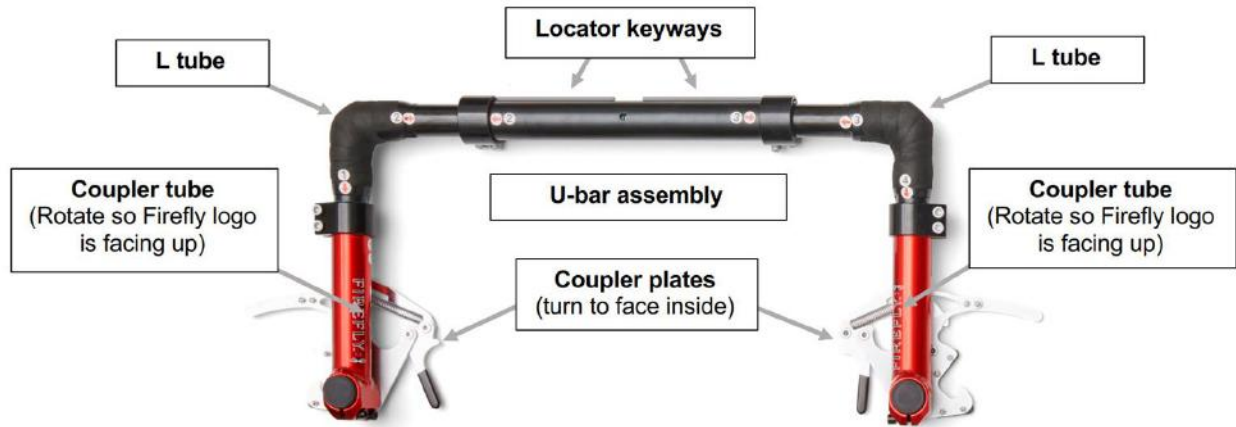

Install stem and handlebar

Next install the stem onto the Firefly frame. Pull open the frame’s quick-release clamp at the top of the frame. Insert the stem with the bend facing away from the battery and push the quick-release clamp closed. Position the middle of the handlebar into the stem's quick-release clamp. Insert the quick-release screw, tighten the nut, and close the lever to secure the handlebar to the stem. Adjust the telescoping stem using the frame’s quick-release clamp as needed for comfortable handlebar height.

Install Firefly frame

Open the quick-release crossbar clamp by rotating the red safety latch to the “up” position. Then open the clamp (1), and attach the U-bar, with the U-bar fitting securely into the horizontal slots in the clamp (2). Close the clamp, making sure both quick-release screws are tight. When the screws are properly tightened, a strong but not excessive force from the palm of the hand is needed to close the clamp (3).



Make sure the U-bar is level by checking with a level placed on top of the L-tubes. You can also check with a ruler that both sides of the U-bar are the same height off the ground. Use the supplied torque handle and the 5 mm hex bit to tighten all 12 bolts on the 6 clamps on the U-bar. Twist the torque handle clockwise until you hear a “click” sound and feel the torque handle release pressure.

Install kickstands

The Firefly™ 2.5 comes with two optional “kickstands” with small roller wheels, which support the Firefly when removed from the wheelchair, and make attaching and removing the Firefly easier.



There are two ways to install the kickstands. The Firefly will be most stable when removed from the wheelchair if the kickstands are installed with the bend facing rearward towards the wheelchair (A). When installed this way, the kickstands may interfere with the caster wheels, and can instead be installed with the bend facing forward away from the wheelchair (B). In either orientation, the kickstand clamps must be placed next to the coupler tube clamps and not near the coupler plates that attach to the mounting clamps (C). Using the 4mm hex wrench, tighten the four screws on the kickstand clamp.

Tighten the screws labeled 1 to 4, each a little at time, in the order as shown in (C). If the clamp pulls too close on one side, loosen the screw that is pulling it close and tighten the remaining screws with more tension. Finish by gently tightening the center set screw, labeled 5, with the 2mm hex wrench.

Attach Firefly™ 2.5 to wheelchair

First apply the wheelchair's wheel locks. Next lock the Firefly's steering by twisting the headset clockwise until the line on the bottom of the headset turns red. A red line on the bottom of the headset means the steering is locked, convenient for installing and storing the Firefly. A green line on the top of the headset means the steering is unlocked.

With the Firefly's steering locked, lift it by the handlebars, and gently position the rear hooks of the coupler plates so that they contact the rear pins of the mounting clamps (1). Push the middle of the handlebar forward with one hand until the caster wheels lift fully off the ground, then use the other hand to rotate the coupler plate's locking lever forward to a horizontal and locked position (2). Now switch hands to hold the handlebar forward with the opposite hand and rotate the second coupler plate's locking lever forward to a horizontal and locked position (3). Check that the green curved line is visible on the inner surface of each coupler plate, showing that the hooks on the coupler plates are fully closed and secure on the pins of the mounting clamps. Unlock the steering by twisting it counterclockwise until the line on the top of the headset turns green (4).



IMPORTANT! The locking levers must be fully closed and secure before the Firefly™ 2.5 can be safely used. A curved green line appears on the inner surface of the coupler plate when it is fully closed and locked onto the pins. Do not use the Firefly™ 2.5 if you cannot see this curved green line.

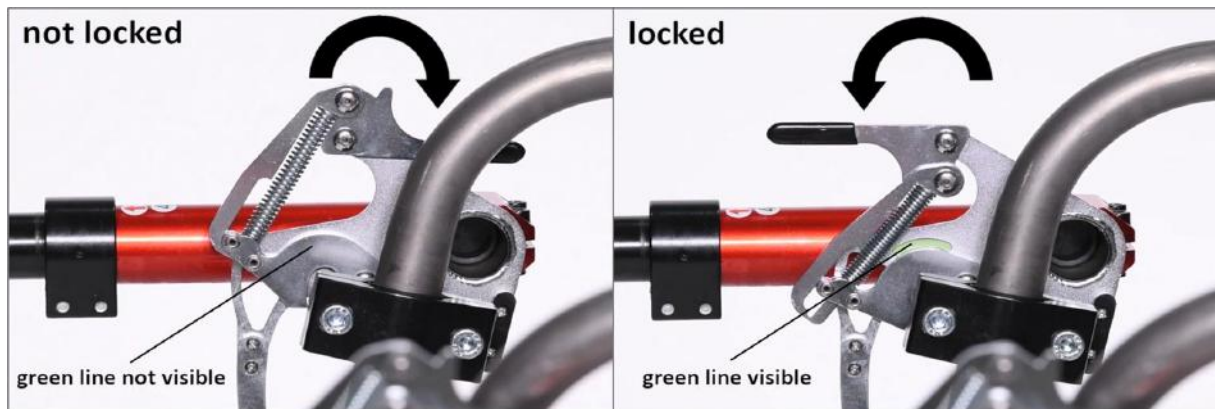

To remove the Firefly™ 2.5 from wheelchair

To remove the Firefly from the wheelchair, following the same procedure as attaching it to the wheelchair but in reverse. First lock the steering by twisting the headset clockwise until the line on the bottom of the headset turns red. Apply the wheelchair's wheel locks. Push the middle of the handlebar forward with one hand, then pull one of the coupler plate's locking lever rearwards to the unlocked position. Next push the middle of the handlebar forward with the opposite hand, maintaining enough force to keep the caster wheels lifted off the ground, then pull the other coupler plate's locking lever rearward to the unlocked position. Now gently lower the caster wheels to the ground by slowly reducing pressure on the handlebar.

The optimal installation angle for your wheelchair attachment



Good:

- 1) The chair clamps mounted high on straight tubing
- 2) Tire is as close to the foot rest while still allowing ample foot clearance from the tire while steering
- 3) The handlebar is high enough to clear the knees and allow body torso clearance when steering



Good:

- 1) In some cases this angle is the only way to mount onto smaller width chairs meant for smaller riders or some folding chairs

Bad:

- 1) The chair clamps are mounted too low
- 2) Lost traction on the front wheel
- 3) Not enough clearance to clear the knees and or body torso when steering





Bad:

- 1) The chair clamps are mounted too low
- 2) The tire is too close to the foot rest and will not allow foot clearance while steering
- 3) Lost traction on the front wheel, ineffective steering
- 4) The handlebar is pushed too far forward and the rider will have to lean forward while riding all the time

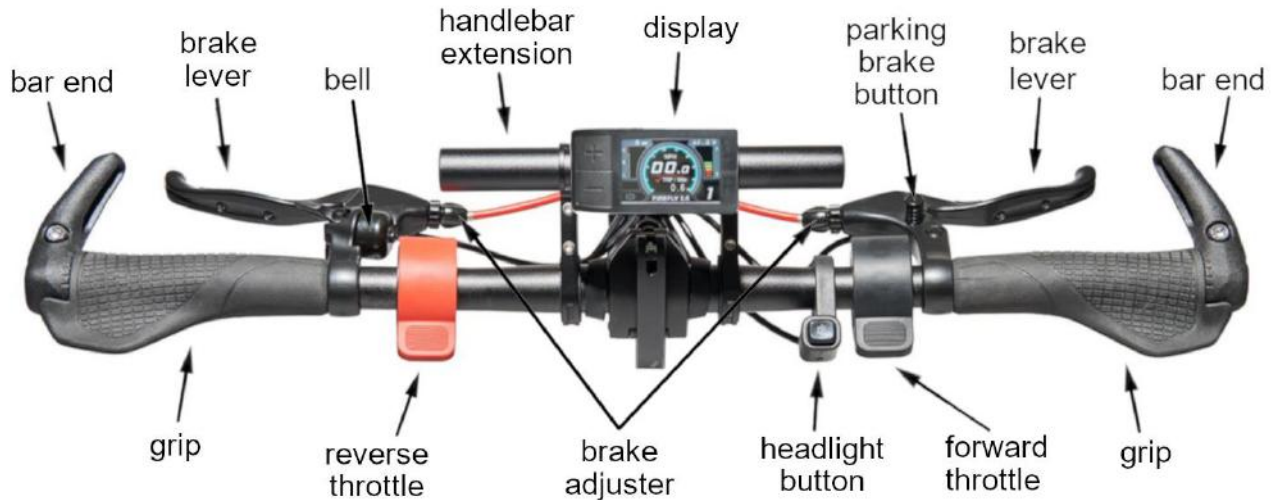
4. Operating the Firefly



To turn on the Firefly: Press the round black button on top of the battery once. If the battery is working, an LED light next to the button will quickly cycle through red, green, and blue colors, then remain a solid red, green, or blue, indicating the battery's charge level. Then press and hold, for two seconds, the right-hand button of the two buttons on the bottom of the display, which is labeled with the power on/off symbol: . When the Rio mobility logo appears, the unit is on and ready to use.

To turn off the Firefly: Press and hold, for two seconds, the right-hand button of the two buttons on the bottom of the display (the power on/off  button). Alternatively, press and hold, for three seconds, the button on top of the battery.

To move forward: Press and hold down the flat part of the (black) forward throttle, located on the right side of the handlebar just to the left of the right-hand brake lever.

To move in reverse: Press and hold down the flat part of the (red) reverse throttle, located on the left side of the handlebars, just to the right of the left-hand brake lever.

To stop: Pull both brake levers until the Firefly stops moving. The right brake handle operates the right brake, and the left brake handle operates the left brake. When either brake lever is pulled, an "electronic brake" shuts off the motor. When the electronic brake is active, the motor cannot turn on, and a symbol appears in bright yellow in the lower-left corner of the display.

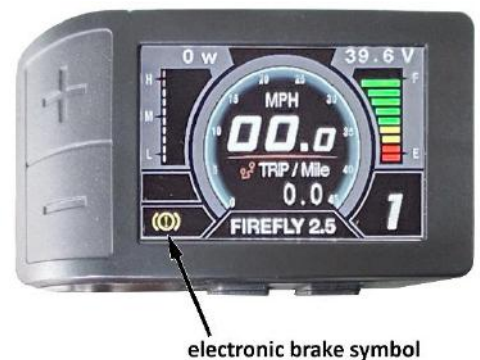
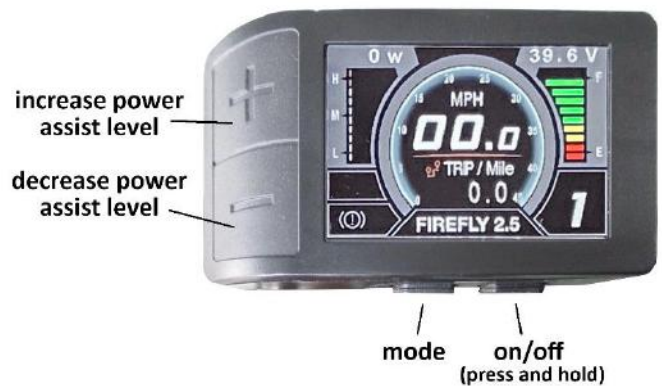

To increase the power assist level: Press the large plus [+] button in the upper-left corner of the display once to increase the power assist by one level. The power assist level, ranging from 1 to 5, is shown in the lower-right of display. At the highest power assist level of 5 the Firefly travels at 12 mph (19 km/hr).

To decrease the power assist level: Press the large minus [-] button in the lower-left corner of the display once to decrease the power assist by one level.

To turn the headlights on or off: Press the headlight button on the right side of the handlebars, located to the left of the (black) forward throttle. The headlights will stay on until the button is pressed again.

To ring the bell: Pull the small lever on the bell, which is attached to the left brake lever.

To charge the battery: Plug the supplied battery charger into the charging port located on the right side of the battery near the bottom of the battery. Fully charging the battery takes between 3 and 5 hours. Remove the battery from the charger when it has finished charging. **Never leave the battery charging overnight or leave the battery unattended while charging.**

To charge or use a personal device with the battery: Plug the device into the USB port located on the right side of the battery near the top of the battery.

5. Maintenance

Inspection / Maintenance Item	Initially	Monthly	6 Months
Check and Tighten Hardware	X	X	
Tighten Headset Compression Nut			X
Brake Pad Wear and Adjustment			X

Temperature and Humidity

Operate the Firefly™2.5 only at temperatures from 14 to 104 degrees F (-10 to 40 degrees C). Charge the battery at temperatures from 41 to 77 degrees F (5 to 25 degrees C). Store the battery at temperatures from 14 to 77 degrees F (-10 to 25 degrees C). The Firefly™2.5 is water-resistant, not waterproof. A light drizzle is not detrimental, but we recommend covering the battery and controller with a plastic bag if you're caught in heavy rain. Clean the Firefly™2.5 with a damp cloth. Do not soak or spray with water or use detergent. Lubricate as needed after cleaning.

Tighten axle nuts

Tighten both nuts on the ends of the axle monthly to a torque of 30 ft-lb (40 Nm). Failing to tighten the axle nuts can result in the axle turning, which will cause the motor cable to wrap around the axle, pulling the cable out of the motor and damaging it.

Tighten hex bolts

Tighten the bolts on the mounting clamps and U-bar on a weekly basis when using the Firefly™2.5 regularly. All four hex bolts on the mounting clamps and all twelve hex bolts on the U-bar must be tightened using the torque handle set to 12 Nm of maximum torque (included in the set of accessories).

Do not adjust Torx bolts

Do not attempt to adjust any Security Torx bolts (which have six-pointed star pattern heads and a pin in the middle). These bolts have been adjusted at the factory and do not need any additional adjustment.

Battery care

Use only the supplied charger to charge your battery. Remove the battery from the charger when it is finished charging; never leave the battery plugged into the charger overnight or unattended. Never charge the battery near a bathroom, sink, drain, microwave, heater, fireplace, air conditioner, or other appliance. Avoid leaving the battery in an automobile or garage, as it could be exposed to excessive temperature or moisture. Store the battery in a cool, dry place away from heat, moisture, and sunlight. Never leave the battery fully charged or fully depleted while in storage, as this may decrease the overall lifespan of the battery. When in storage, the battery should be charged to about 65%, and then charged every two months for 30 to 45 minutes in order to maintain this level of charge.

Damaged or missing parts

Immediately replace any damaged, missing, or badly worn parts with manufacturer-approved parts. Please contact your dealer or: support@riomobility.com for information on replacement parts.

Flat tires

Inflate the tire to 35 psi (2.4 bar) of air pressure. Screw the L-shaped valve extender onto the tire's valve stem if you are unable to insert a pump head onto the valve stem without the extender.

Keep the box

We recommend keeping the cardboard box the Firefly™ 2.5 was shipped in, for convenient storage of the Firefly, accessories, and tools. The box can also be used to ship the Firefly to our shop for repairs.

6. Troubleshooting

When climbing a hill, the front wheel slips.

The front wheel is too far forward of your center of gravity. Adjust the Firefly so that the front wheel is as close as possible to the wheelchair without interfering with the wheelchair's footrests or your body. While climbing, lean forward to place more weight on the front wheel.

The Firefly™ 2.5 won't turn on.

Check that all the connectors are connected. Make sure that the battery is fully charged by charging it for 3 to 5 hours, until the light on the charger turns from red to green. Press the button on the top of the battery once to turn it back on, then press and hold, for two seconds, the right-hand button of the two buttons on the bottom of the display.

The Firefly™2.5 turns on but won't move forward or reverse.

If neither the forward nor reverse throttle work, the electronic brake may be engaged. This feature cuts off all power to the motor when either brake lever is pulled. A circle symbol in the lower-left corner of the display appears in bright yellow when the electronic brake is on. Check that nothing has broken or moved out of place along either of the brake lines. Check that the brakes are not extremely tight and the cables are still attached at the brakes, that the brake cable housing is in place at both the brake end and the brake lever end, and that the brake levers are undamaged.

Display Error Codes (*Shown on bottom of your display screen after start up*)

01E Display Signal error:

Check the handlebar display wire connector. Contact your dealer if the problem persists.

02E Controller Protection:

Check all wire connections. Contact your dealer if the problem persists.

03E Motor Phase Power Abnormality:

Check motor connector, make sure the motor wire is not damaged. Contact your dealer if problem persists.

04E Low battery:

Reseat your battery, press the battery switch and charge your battery completely. Contact your dealer if problem persists.

05E Brake switch error:

Check brake wire connectors. Test that pulling each brake lever illuminates the electronic brake symbol in the lower-left corner of the display. Contact your dealer if problem persists.

06E Throttle error:

Check throttle wire connectors and make sure your throttle spring is not stuck. Try reversing the throttles to find which throttle is faulty. Contact your dealer if problem persists.

07E Motor Hall Sensor Abnormality:

Check motor connector, make sure the motor wire is not damaged. Contact your dealer if problem persists.

7. Safety

Safety Checklist

- A helmet and safety belt are recommended.
- Engage the wheel locks on your wheelchair before attaching or detaching the Firefly™2.5, also engage the parking brake button located on the Firefly's right brake lever.
- Make sure the coupler plates are fully closed and locked onto the mounting clamps by checking that the curved green lines on the sides of the coupler plates are visible.
- Check to make sure all bolts are tight, and all quick-release clamps are securely closed.
- Make sure the hand brakes work properly before using your wheelchair attachment.
- Do not add any parts or accessories not authorized by Rio Mobility to your wheelchair attachment. Any modifications could be unsafe and will void your warranty.

Before You Ride

Make sure that your Firefly™2.5 is installed, adjusted, and maintained properly. Do not use the Firefly™2.5 until you and your health care professional determine that you have the ability to use it safely in an uncontrolled environment.

Use your wheelchair as described in your wheelchair manual and use the Firefly™2.5 in the same safe manner that you would a wheelchair with push-rims. Follow all additional warnings and instructions for the Firefly™2.5 in this manual.

Controlling the Firefly

Always watch out for vehicle traffic and pedestrians when riding on the road and sidewalk and follow all traffic regulations. Follow all local regulations that apply to this device.

Always mind your speed, especially when turning. You should have full control of your wheelchair at all times. Do not exceed the maximum allowable speed recommended by your wheelchair manufacturer.

Three-wheeled vehicles are less stable in turns compared to wheelchairs alone, so be careful to keep all three wheels on the ground and moderate your speed when approaching curves.

Be careful when reaching and leaning left or right from your wheelchair with your handcycle attached — the longer wheelbase makes it less stable in sideways leans than your regular wheelchair. Narrow wheelchairs are less stable in general, so be extra careful if your wheelchair is particularly narrow.

Obstacles

Be careful going over bumps and curbs over two inches (50mm) high. Your caster wheels may strike these surfaces, causing a loss of control. Use your wheelchair's push-rims to get over bumps, not the wheelchair attachment. Approach bumps and curbs straight on and at low speed to avoid injury or damage to your wheelchair. Be aware of road surfaces, especially on inclines. Watch out for water, ice, and oil film.

8. Limited Warranty

Rio Mobility warrants the Firefly™ 2.5 for one (1) year from the date of initial consumer purchase. This warranty covers any **MANUFACTURING** defects in materials and workmanship.

Rio Mobility warrants the lithium-ion battery for six (6) months from the date of initial purchase. This covers any **MANUFACTURING** defects in materials and workmanship.

THIS WARRANTY DOES NOT COVER DAMAGE TO CONNECTORS, CONNECTOR PINS, CABLES OR WIRES, PULLED OR SEVERED MOTOR WIRES, DROPPED CHARGERS AND BATTERIES, DAMAGE DUE TO WATER, OR ANY PHYSICAL DAMAGE THAT OCCURS AFTER RECEIPT OF PRODUCT.

If you see or suspect any damage or defects, report the problem upon receipt of the product. Failing to comply with the battery care instructions risks voiding your warranty.

This warranty is only available for the original owner or purchaser and is non-transferable.

LIMITATIONS

This warranty is **VOID** if:

- **Assembly and installation are not performed according to the instructions**
- **Preventative and routine maintenance has not been performed**
- **The serial numbers on the frame, motor, controller, or battery are removed or altered**
- **The motor, controller, or battery are opened, altered, or disassembled**
- **The wheelchair attachment is used in any competitive event**
- **The wheelchair attachment is used in stunt riding, jumping, or similar activity**
- **The wheelchair attachment is submerged in or sprayed with water; this includes accidental exposure to rain (applies mainly to electrical parts)**
- **The wheelchair attachment is used in a manner contrary to the instructions in this user's manual**
- **Any modifications are made to the device**
- **You accidentally run into objects and obstructions**

Please contact your dealer for installation, service, or warranty needs.