

Owners Manual and Service Record Quingo Flyte

This manual must remain with the product throughout its life so please keep it in a safe place.

Complete all the information within this document and if any items are not clear contact your service provider immediately.

NOTICE

This product was supplied by.

Product Model Number.....

Serial Number.....

Date of Purchase.....

This product is manufactured by: AVC LTD,
Sovereign Court, 230 Upper Fifth Street, Central Milton Keynes, Bucks MK9 2HR

Table Of Contents

NOTICE

The contents of this document regarding photographs and text may change because of specification upgrades. AVC LTD retains the right to change specifications of its products without prior notice.

Subject	Page No.
Table of Contents	2
Part 1: Quingo Flyte	3
Safety Information	3
Intended Use of the Vehicle, Intended User	4
EMI Information & Life Expectancy of the Product	5
Overview of Product	6-7
Display and Controls	8-10
Emergency Brake	11
Free Wheel Device	12
Safety Display Warning	13
Day Time Running Lamps	14
Anti-tip Device	15
Seat Adjustments	16
Footplates & Seat Belt Adjustments	17
Transporting the Scooter	18-19
Front & Centre Baskets	20
Battery Charging, General Care	21-22
Daily Check List & Safety Information	23
Important Notes When Driving Your Vehicle	24
Storage & Cleaning	25
Troubleshooting Guide	26
Scooter Fault Indicators	27
Common Question	28
Reporting a Fault and Servicing Information	29
Service Check List QUINGO SERVICE ENGINEER ONLY	30
Service Log QUINGO SERVICE ENGINEER ONLY	31
Technical Information Regarding EMI	32
Guarantee & Warranty	33
Technical Specification	34
Technical Specification Important Notes	35
Part 2: Quingo Docking Station	36
How to 'Load' the Quingo Flyte	37-47
How to 'Unload' the Quingo Flyte	48-57
How to Install the Quingo Docking Station	58-68
How to Remove the Quingo Docking Station	69-75
Additional Information- Noise reduction wedges	76

Part 1

Quingo Flyte.

Safety Information

1. **PLEASE READ THIS MANUAL THOROUGHLY BEFORE DRIVING OR OPERATING THE VEHICLE.**

Every mobility scooter operates differently. Do not assume they are the same. If you have any doubt about the content of this manual phone your service provider immediately. Read the instructions contained within the document, they apply to the Quingo Flyte. The photographs in this document depict the Quingo Flyte.

2. **ALWAYS MAINTAIN THE VEHICLE CORRECTLY AND ENSURE ONLY A QUINGO TRAINED TECHNICIAN SERVICES IT REGULARLY. Warning:- Any modifications made to the Quingo Flyte or Docking Station will invalidate the warranty.**

Safety Notices

Within this manual there are important safety notices.
They are clearly marked on the appropriate pages.
Make sure that you understand these notices.
If any part is unclear phone your service provider.

© 2016 Advanced Vehicle Concepts Ltd

No liability is assumed with respect to the use of any information contained in this publication. While every precaution has been taken in the preparation of this publication Advanced Vehicle Concepts Ltd assumes no responsibility for errors or omissions nor is any liability assumed for damages resulting from the use of information contained in this publication. This publication, as well as the operational details described herein, is subject to change without notice.

Intended Use of Scooter & Intended User

Intended Use of the Vehicle

Designed solely for use by a disabled person (up to the maximum recommended weight) who requires a mobility scooter with maximum versatility, a safe, comfortable seating position and good manoeuvrability. This unit can be transported in the rear of the vehicle secured to the docking station. Weight and dimensions should be checked before purchase.

This vehicle is classified according to EN 12184 as a class B mobility product (for indoor and outdoor areas). Speed, range, turning circle, safe climbing ability, maximum obstacle height and permissible operating conditions can be found in 'Technical Specifications'.

These vehicles are not intended to run in deep water (over 5cm/ 2") or muddy areas but they can be run on hard ground. Avoid sandy or gravel areas as this can seriously affect the range and traction. These products are not intended as off road vehicles.

This section describes what the scooter is designed to do and what it's not. If you use the scooter outside its intended use your guarantee will be void and you may cause danger to yourself and others.

EMI Information & Life Expectancy of the Product.

Information regarding Electromagnetic Interference (EMI)

This section contains information on the possible effects of electromagnetic interference to your vehicle.

EMI refers to the effects electromagnetic energy might have on the control system of your vehicle. The interference could cause the brakes to release, the vehicle to move by itself or damage the electronics.

There are broadly three types of sources of electromagnetic energy:

1. Hand Held, Short Range Portable Transceivers. Examples include: CB radios, walkie-talkies, security, fire and police transceivers, mobile phones and other devices that transmit a signal even when not in use.
2. Medium Range Mobile Transceivers. Examples include: police, fire, ambulance and taxi transceivers.
3. Long Range Transmitters and Receivers. Examples include: radio and television towers and amateur (HAM) radios.

There is an immunity level that has to be met by law and your scooter has been tested to that required level. For a full technical explanation see Page 32 in this document.

WARNING

Even though your vehicle meets the requirements, it is recommended that you follow certain precautions.

1. Do not operate hand held transceivers such as CB radios or mobile phones while the vehicle is switched on.
2. Be aware of transmitter masts, such as television and radio stations. Avoid getting close to them.

If your vehicle starts to operate by itself, switch it off and call your service provider. Report all faults of this type.

Life Expectancy of the Product

The life expectancy of the product is 5 years, depending on usage and product care, So please ensure that your product is used in strict accordance with the intended use as set out in this document and all service and maintenance requirements are carried out as recommended.

The estimated life expectancy may be exceeded if the product is used carefully and properly maintained, but it can also be considerably reduced by extreme or incorrect use. Although we estimate the life expectancy for this product it does not constitute an additional warranty.

Overview of Quingo Flyte

The Quingo Flyte has many features. It is important that you understand all the functions and parts of the product before you get started.

The diagram below shows the main features of the scooter and their location on the vehicle. Throughout the handbook, each item as shown below is covered in greater detail, use the image as a quick reference.

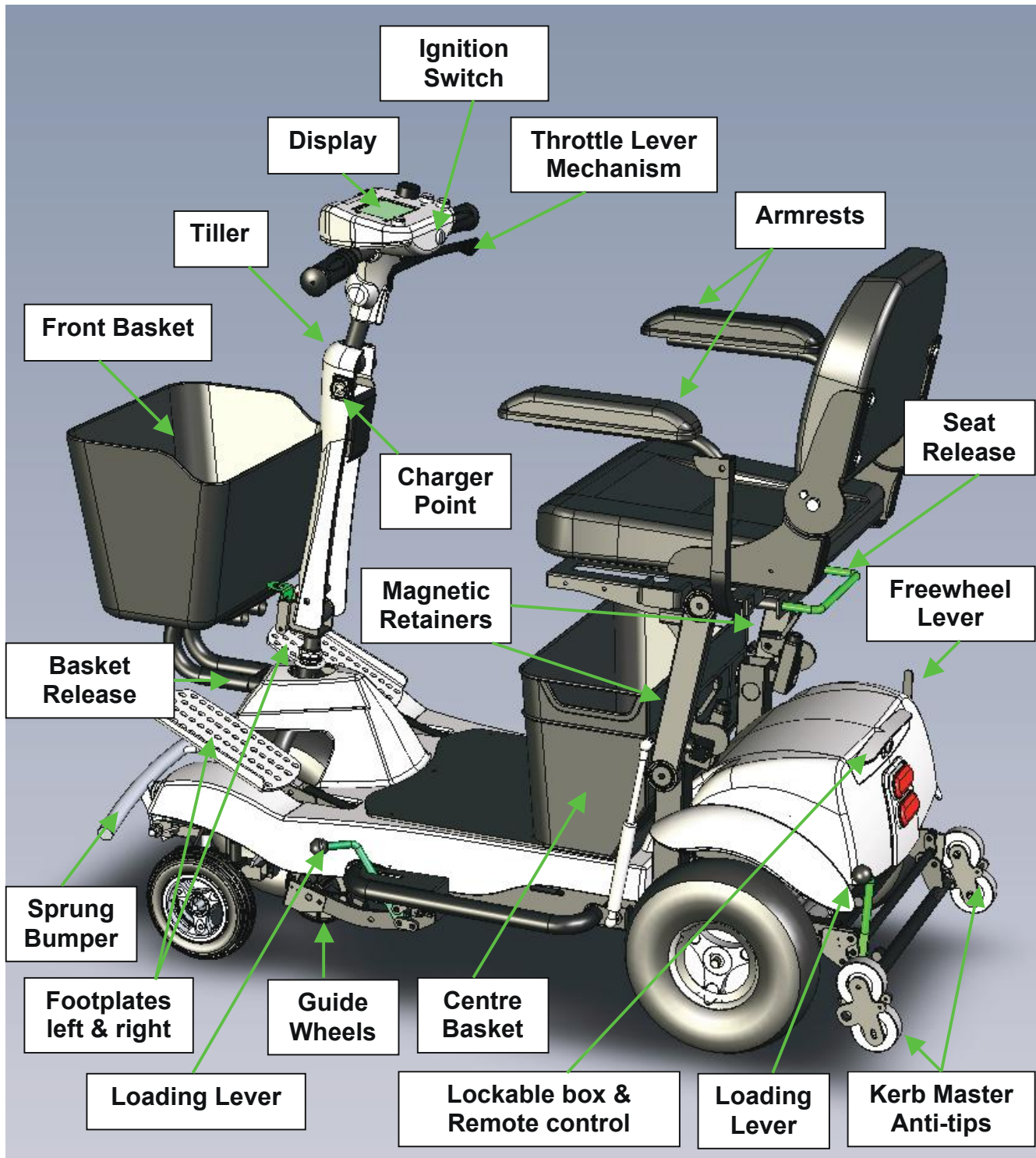

Overview of Quingo Docking Station

The Quingo Docking Station has many parts. It is important that you understand the location of the parts for reference throughout the handbook and DVD. The diagram below shows the main parts of the docking station.

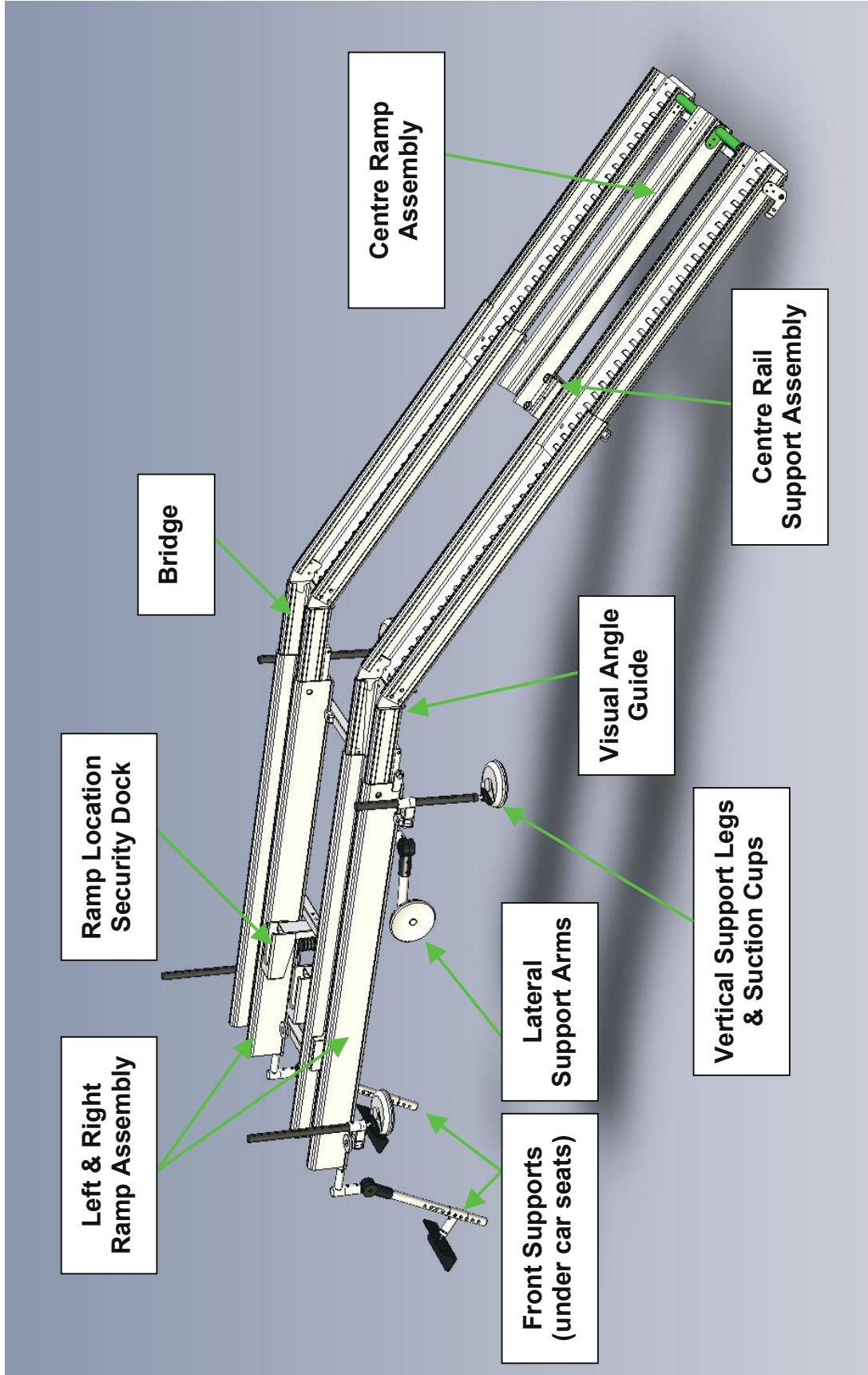

Display & Controls

Your Quingo has many features that other scooters do not have. It is important that you understand all the functions.

The multi-feature digital dash/ LCD display: Insert the ignition key and turn the switch to the right, the display will light up. The only information you need to know for now is the following:-

- The top right of the display in the photograph below is showing 07c, this is the temperature gauge and it will indicate the current outside temperature.
- Below this is a box with “- +” and six vertical bars. This is the battery indicator and when these boxes disappear starting from right to left, the battery is running down.

Do not let the bars drop below 3 before returning home and recharging.

Note for Reading the Battery Indicator

ALL battery indicators are not 100% accurate. The recommended way of reading the available charge in your scooter is to find a piece of flat ground clear of obstacles. Switch the scooter to full speed and pull in the throttle fully. Check the reading on the display which will give your current battery state.

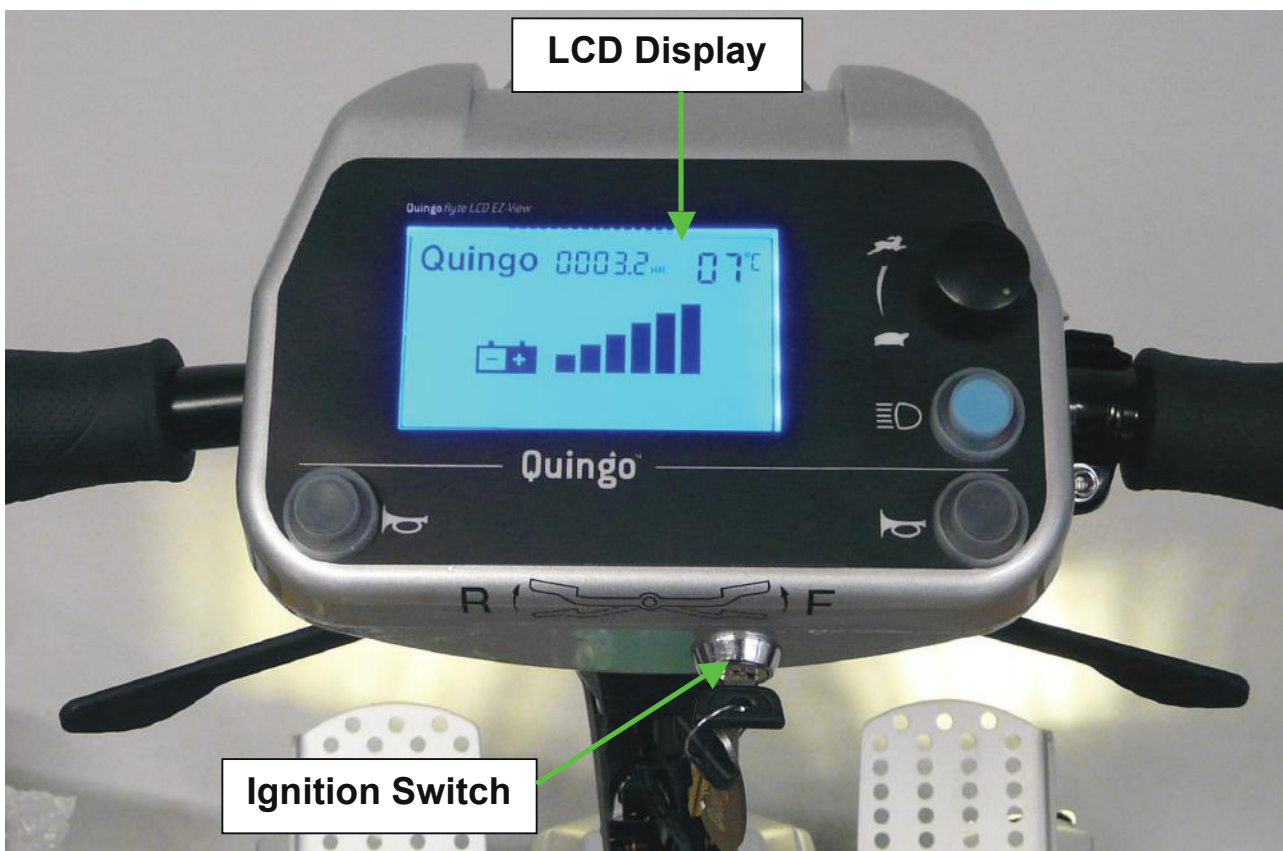

Display & Controls

When various buttons are pressed they will be indicated on the display.

Let's look at the function of the main switches and how they are displayed. Other additional features we will explain later.

Additional Notes on Switches

Notice that you have 2 horn buttons accommodating both left and right handed people. You can press either button to activate the horn.

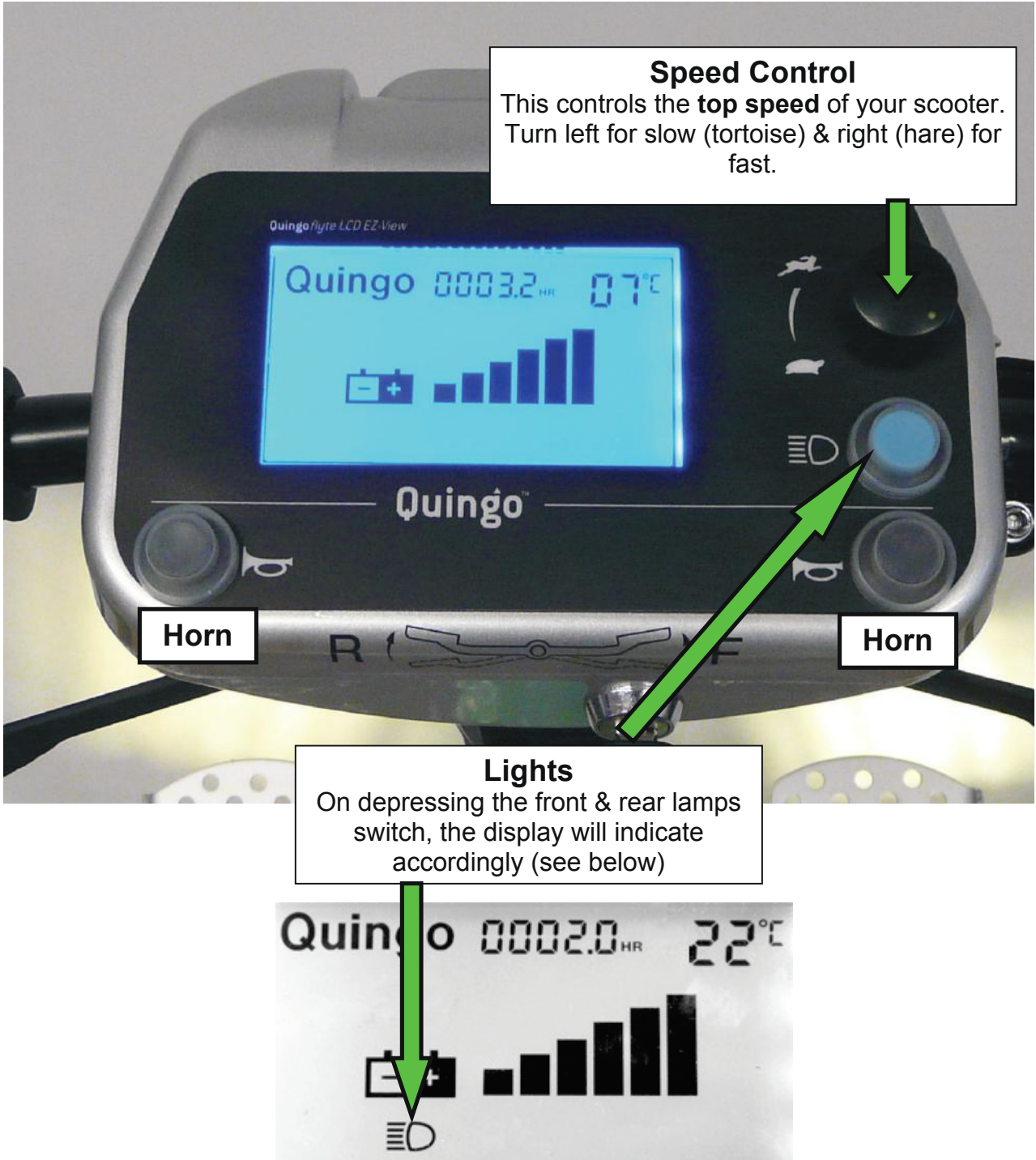

Display & Controls

WARNING NOTICE!!

The lever mechanism as shown in the diagram below should be treated with care as it could become damaged if misused. **Do not push or pull both levers in at once.** This will damage the mechanism. Carry out the following recommended checks:-

1. **(Carry out daily)** Before using the scooter, check the throttle lever mechanism has full and free movement. With the **ignition off (see 1.)** and the key removed, push the lever in fully on the right hand side then release (**see 2a**). The lever should return immediately to the normal position (**see 2**). Push the left hand side lever in, fully, then release (see 2b). The lever should return immediately to the normal position. If the lever does not return immediately to the normal position (it sticks) contact your provider immediately and **DO NOT ATTEMPT TO OPERATE THE SCOOTER.** The Handbrake (**see 3**): This is for emergency use only. (In the unlikely event that the main braking system should fail this can be used to slow the

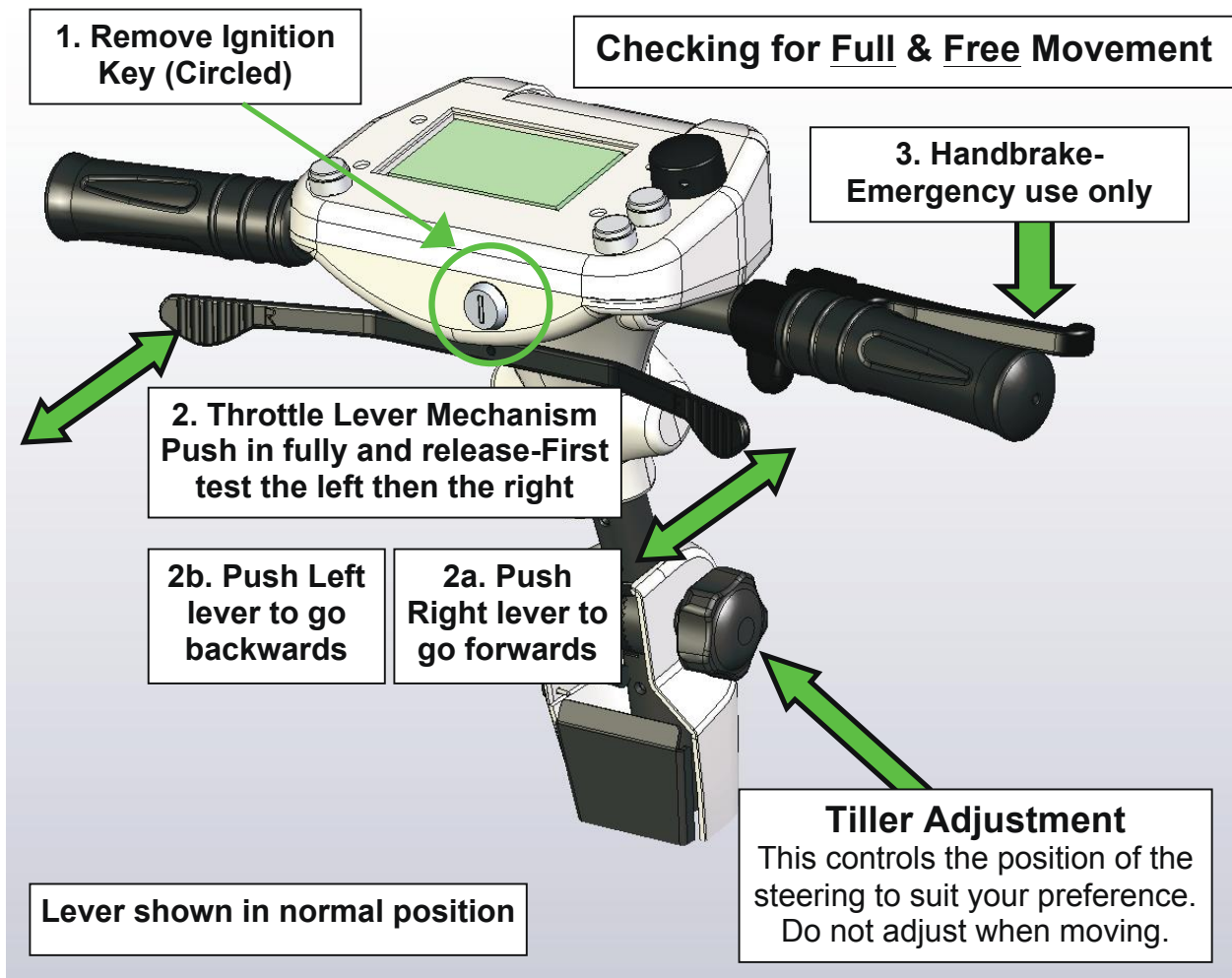

2. Never lean or place your body weight on the levers. This will damage the mechanism.

3. Do not attach shopping, dog leads or anything to the lever. Take care if you use a weather cover, when removing it don't catch the lever and damage it.



Caution: If the ignition switch is turned off while the vehicle is at speed the vehicle will come to an abrupt stop. If you are in a situation where you need to stop abruptly use the emergency brake. Only switch off the ignition as a last resort.

Emergency Brake

A Brief Explanation of How The Brakes Work On Your Scooter.

Your scooter has 3 braking systems:-

1. The First is the emergency brake. This is situated on the tiller (see image below). This is a hand operated brake to be used in an emergency only.
2. The Second is the electromagnetic brake or Automatic handbrake. When you move off, this releases automatically. When the scooter stops it also engages automatically and stops the scooter rolling forward or backward.
3. The Third is the regenerative brake. This works when you release the accelerator lever. The faster you release the lever the faster the machine slows down. When it slows down enough the automatic brake engages.

If you are riding the scooter and you feel there is a fault and the scooter is not braking correctly pull in the lever (Arrowed) to slow the vehicle. Immediately switch off the ignition and phone the Service Provider.

Note:

If you should become confused with the braking, just release the lever mechanism and the vehicle will come to a stop.

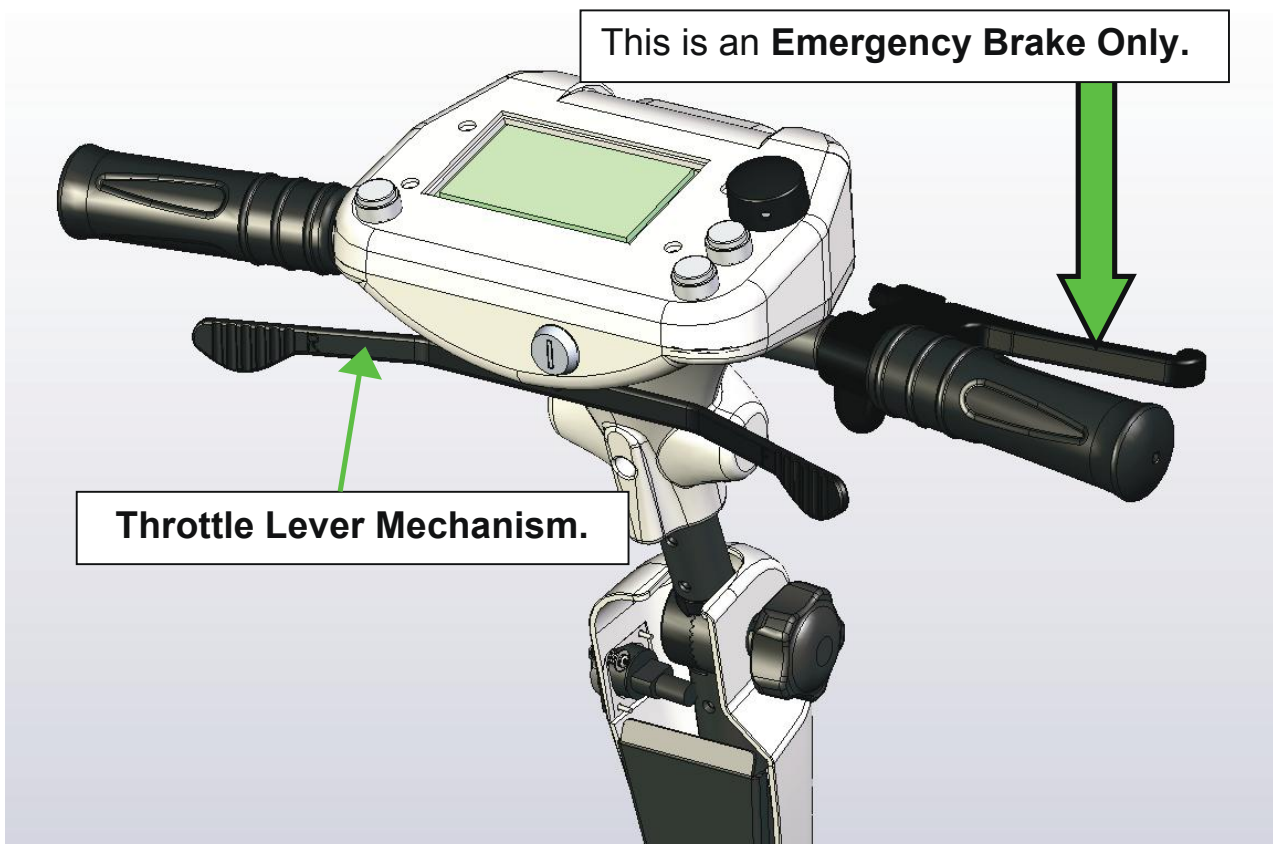

DO NOT USE THE EMERGENCY BRAKE UNDER NORMAL DRIVING CONDITIONS.
DO NOT DRIVE THE VEHICLE WITH YOUR HAND RESTING ON THE EMERGENCY BRAKE.

Free Wheel Device

Important Safety Notice: The freewheel device allows the vehicle to be moved without power. When the lever is moved forwards the automatic brakes are released. This means there is no braking except for the emergency brake. Follow these instructions and if you are in any doubt contact the service provider immediately.

IF YOU ARE UNSTEADY ON YOUR FEET DO NOT ATTEMPT THIS MANOEUVRE

1. Make sure the scooter is on level ground
2. Remove the ignition key
3. Do not sit on the scooter at any time the vehicle is in freewheel
4. Release the lever (see photograph 1- the arrow indicates direction to release)
5. Push the scooter to the area you require using the emergency brake (Page 11) to control the speed
6. Lock the lever (see photographs 2- the arrow shows direction to lock.)

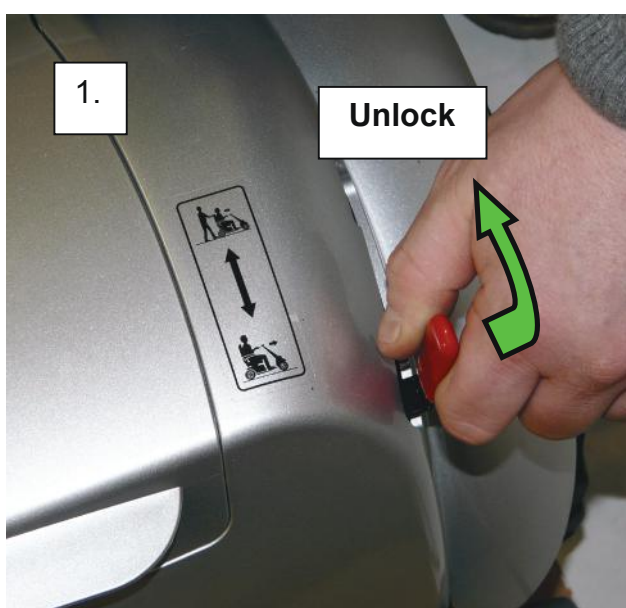

The freewheel release lever is situated to the rear right hand side of the lockable box. This picture shows the vehicle in the locked position.



To release, pull out and forward. This may be quite stiff to operate. The picture shows the vehicle in freewheel mode.

Points when using the freewheel device.

1. **NEVER RELEASE THE BRAKE AND SIT ON THE SCOOTER**
2. **NEVER RELEASE THE BRAKE ON A SLOPE. ONLY ON FLAT GROUND**
3. **ALWAYS REMOVE THE IGNITION KEY**
4. **NEVER RELEASE THE FREEWHEEL LEVER WHEN THE FLYTE IS ON THE DOCKING STATION.**



When you have finished moving the scooter push the freewheel lever back into the locked drive position immediately.

Safety Display Warning

If you forget to lock the freewheel device and try to use the scooter you will see this indication (as circled) on the display:



The spanner means there is a fault and the number 5 means the freewheel is not locked and the scooter will not drive,

To clear the fault:

1. Turn the ignition off and get off the scooter immediately.
2. Lock the freewheel device as shown on Page 12.
3. Turn on the ignition, the spanner and the number 5 will disappear.
4. The scooter will now operate correctly.

Another common rider fault is pulling in the throttle lever mechanism (Page 10) at the same time when turning on the ignition. The scooter will see a fault and the spanner with the number 6 will show on the display. Simply release the lever for a few seconds and the scooter will automatically reset.

You can now drive off.

The full list of fault numbers can be viewed on Page 27

Day Time Running Lamps

For your safety the Quingo Flyte is equipped with Daytime Running Lamps. The 2 lower front lamps situated near the outer front wheels (Arrowed) remain permanently 'ON' when the ignition is switched on. These lamps cannot be switched off.

The Running lamps are not a legal requirement but are an added feature to make other road users and pedestrians aware of your presence.

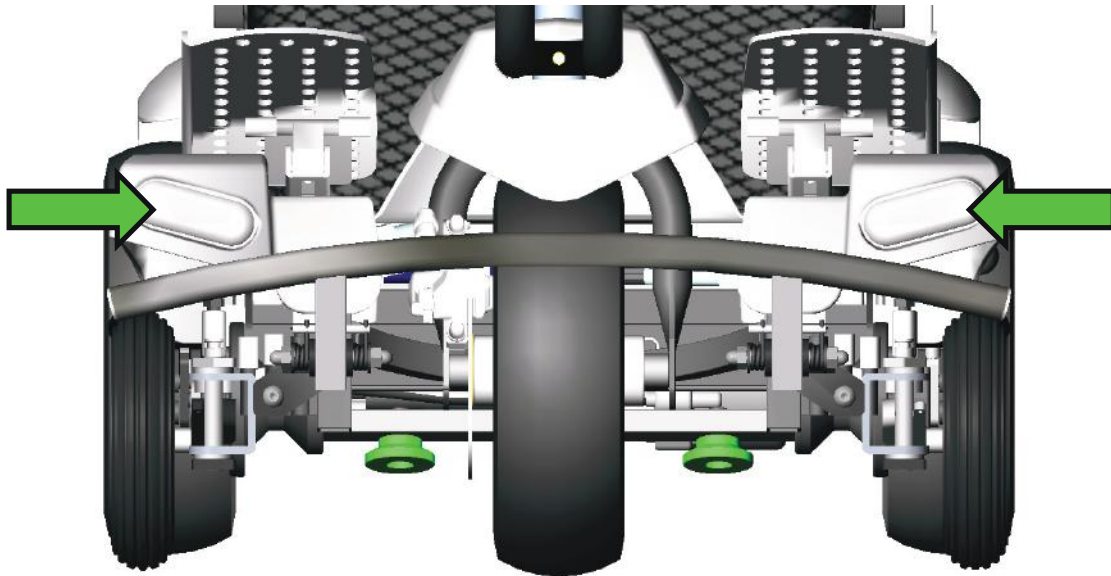

Lights.

1. There are additional lights that can be controlled from the tiller display panel, with an option to have the higher mounted tiller lights on or off.
2. There is a rear brake light which activates automatically when braking.

Anti-tip Devices

The Flyte is fitted with Kerb Master- "Powered Anti Tip" a patented feature that engages the 2 wheels when descending a slope or kerb.

Should the anti-tip wheels come to rest on a kerb there is a possibility that the machine will become "Beached", this means the kerb is higher than the distance between the anti-tip wheels and the ground and can leave the rear wheels spinning and the scooter can become disabled. If this should happen, the 2 anti-tip wheels engage, the rider should drive normally and the vehicle will automatically drive off the obstacle.

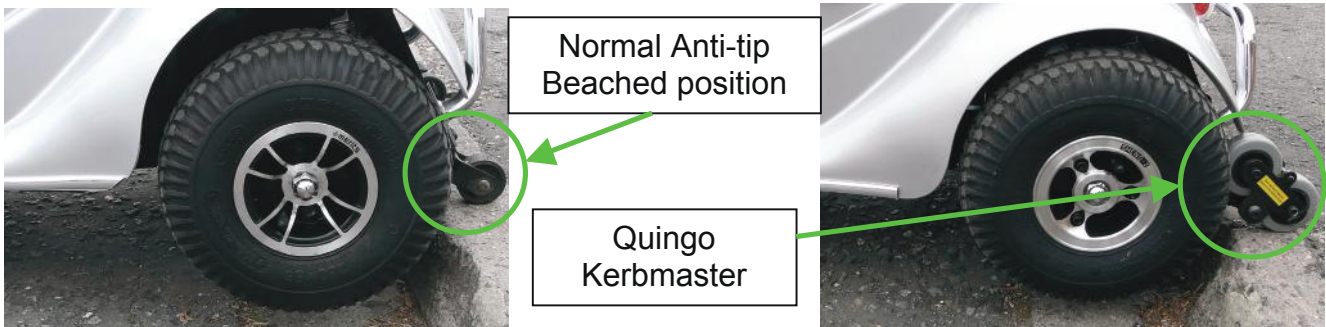

The Anti Tip device is fitted to the rear of the vehicle. Its function is to restrict the vehicle tipping backwards in an extreme situation. This only occurs if the machine is misused. The Kerbmaster Anti-Tip Device can be set in 2 different locations- normal driving position and transportation position. The two diagrams below show the anti-tip wheels:-

1. Driving Position
2. Flyte Mode (Loading Position) for transporting with the docking station

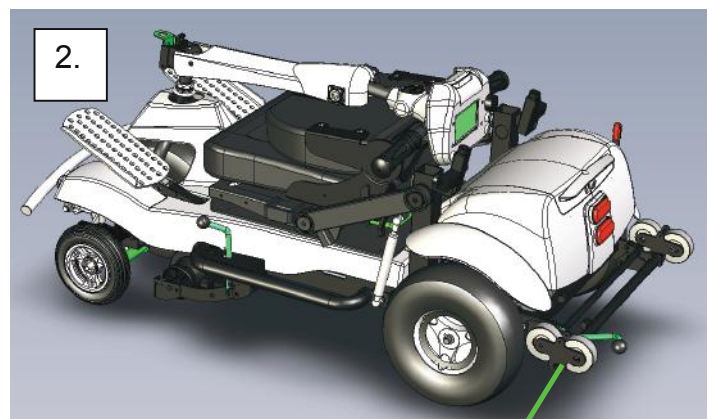
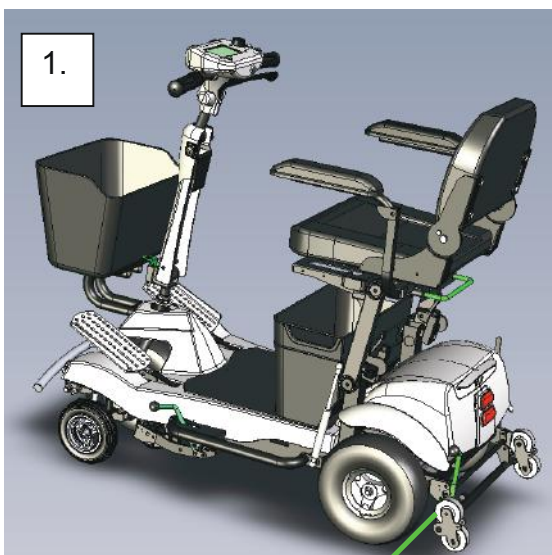

Seat Adjustments

The seating on your scooter can be adjusted to various positions for your comfort. The service engineer will set these adjustments up for you but you will be required to adjust it yourself, especially when folding the Flyte ready to transport into your car.

REMOVE THE IGNITION KEY BEFORE ADJUSTING ANYTHING

Seat Slider: Allows the seat to be adjusted forwards and backwards. Pull the lever upwards and adjust the seat to suit. Release the lever and move the seat slightly back and forth until you hear the seat lock. Always keep the seat as far forward as possible as this aids the stability of the scooter.

IMPORTANT INFORMATION: When you are preparing to 'Load' the Flyte into your car and before starting the seat folding process you need to make sure the seat is in the rear position (furthest from the tiller) to ensure the Flyte folds down to its most compact position.

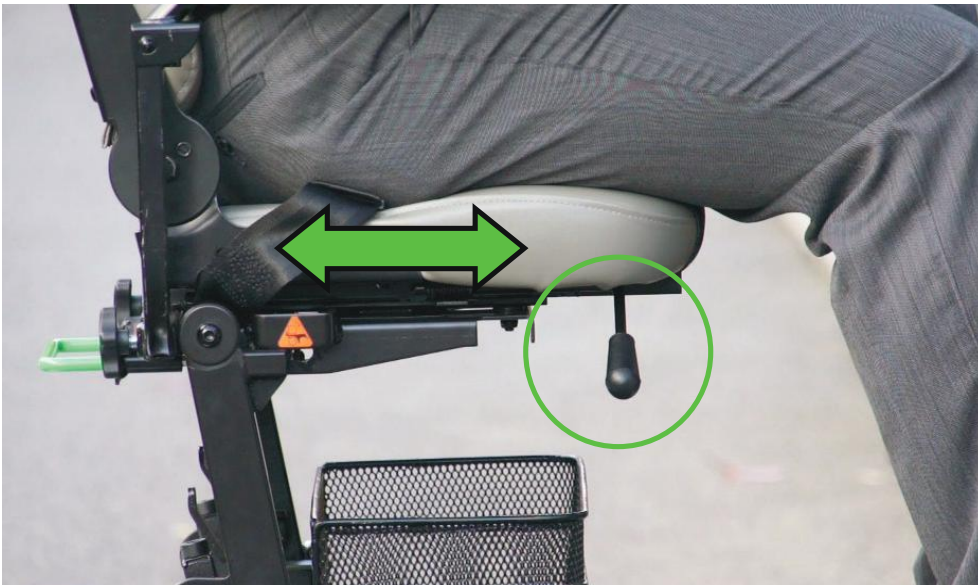

To adjust the width of the armrests loosen the clamps. Adjust the arms in or out to suit your requirements then retighten.

Armrest Removal

To remove the armrests completely loosen the clamps (circled) then pull outwards until the armrest is free. If it will not separate loosen the clamp further.

IMPORTANT- Check that these clamps are tight every day before driving the vehicle

Footplates and Safety Belts

Footplate Adjustment

The footplates can be adjusted for legroom. It is recommended that a service engineer carry this out. If you need to adjust them back or forward, loosen the lock, move into position and lock (you will need a 5mm hex key for this adjustment). Some vehicles are fitted with a lock nut.

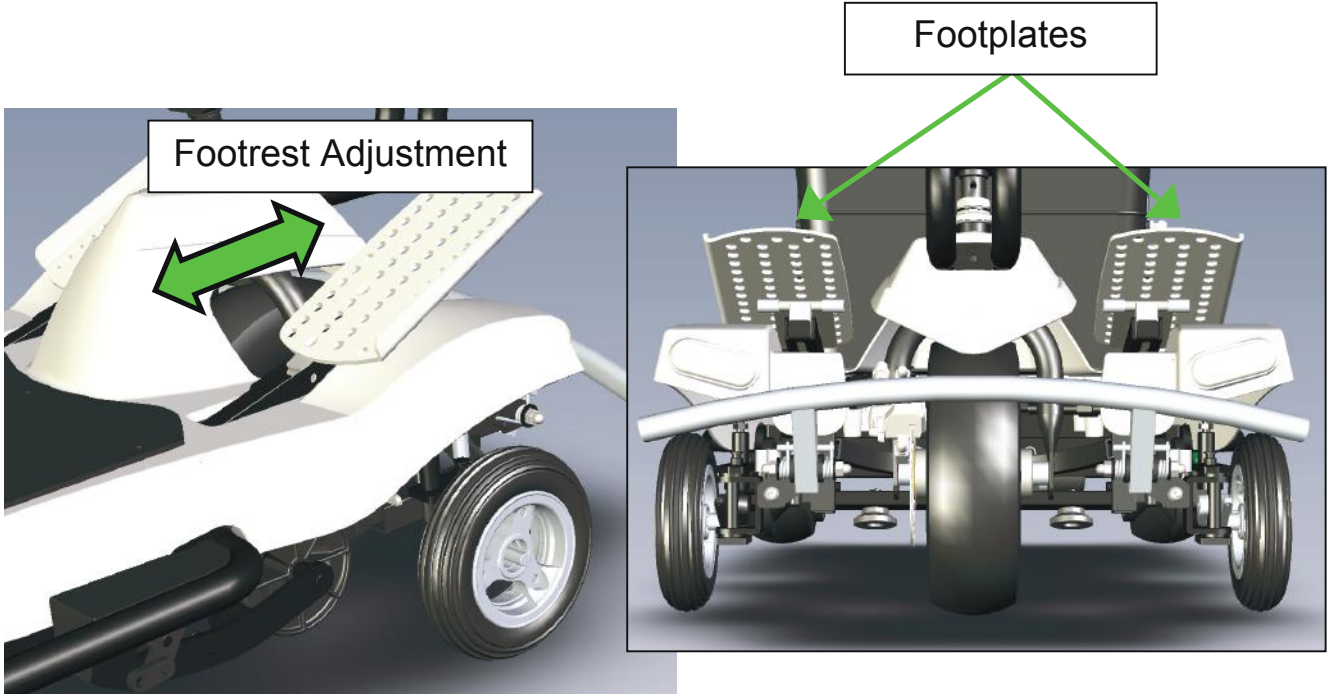

Safety Belt



Use the seat belt whenever you drive the vehicle.

Pull the belt across your lap and connect the buckle. This is achieved by pushing the 2 parts together. When they lock you will hear a "Click".

To release, push the red button marked "Press" and the buckle will release.

**MAKE SURE THE BELT IS
ADJUSTED CORRECTLY AT ALL
TIMES**

Transporting The Scooter (load/ unload position)

The Quingo Flyte is transported using the Quingo Docking Station. There is minimal lifting required to be able to load/ unload the scooter from your car.

The following process shows how to fold your Quingo Flyte, this can be in a confined storage location or ready to load into your car:-

- To ensure the Flyte is folded to a compact position, make sure the seat is in the rear position (furthest from the tiller)
- Remove both Armrests
- Remove Front Basket and Centre Basket.

1. Fold the back support down flat.
2. Push the green seat release lever and tilt the front of the seat upwards and over until the seat unlocks.
3. Now push the seat assembly forwards where it will lower the Flyte's deck.
4. Release the Tiller locking lever and lower the tiller onto the seat's velcro fastening.
5. Folding is complete

Note:- Always check the tiller is in the correct folded position for your vehicle when loading.

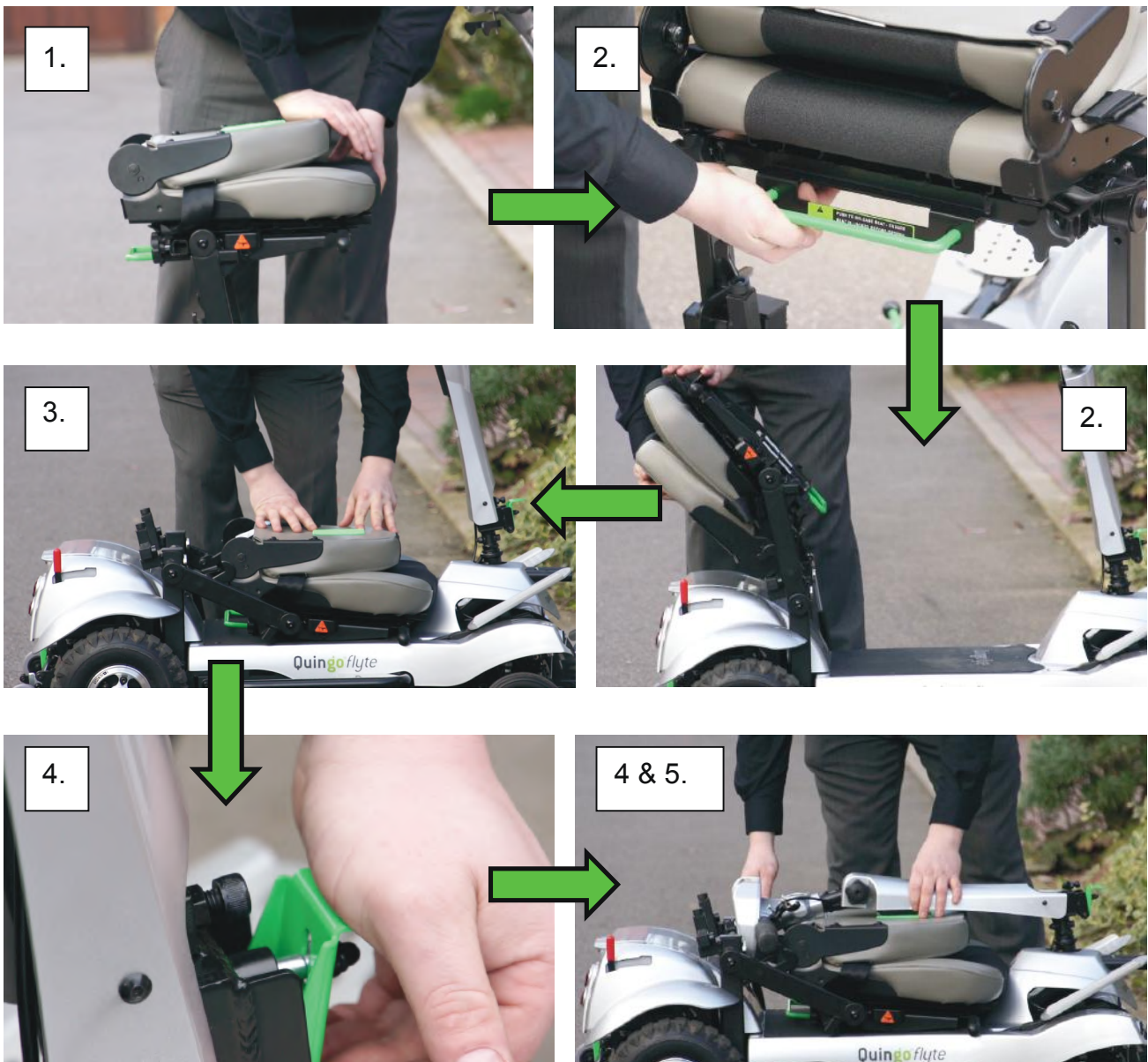

Transporting the Scooter

There are 2 levers located on the vehicle for normal driving; they should be in the positions shown.

When transporting the vehicle on the docking station refer to the information in part 2 of the handbook.

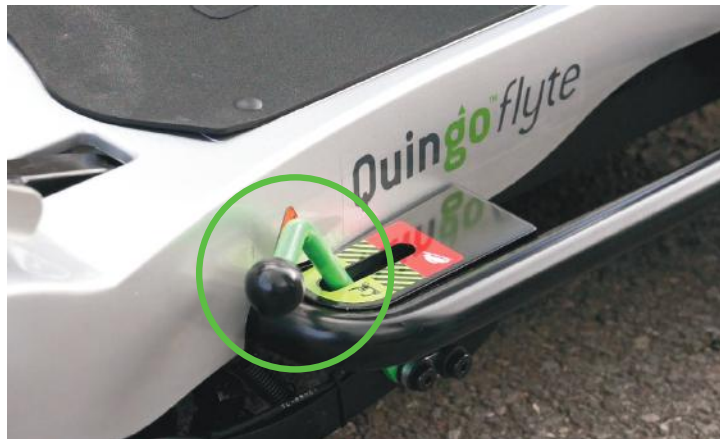

The Remote control is located in the rear lockable box. This should only be used when transporting the Flyte on the docking station.

Caution: Do not leave the remote control out in the rain or allow it to get wet.



Front & Centre Baskets

The Front Basket

To remove the basket pull the pin out and simply pull the basket forward.
To refit the basket, line up the 2 tubes and push the basket as far forward as possible.
Push the pin in fully.



Maximum Weight

The maximum load weight of the front basket is 8kg

The Centre Basket

The centre basket is placed underneath the seat. The basket has two magnetic discs at each corner which locate onto the frame under the seat.

To fit the basket simply line up the magnets, the basket should be attached by magnets



Maximum Weight

The maximum load weight of the centre basket is 10kg



Caution: Please make sure both front and centre baskets are removed before folding the Flyte for transporting.

Battery Charging



Connection Instructions

When your new Flyte is delivered the installed batteries will be partially charged. Fully charge before use.

1. Place your scooter in an area that is dry and well ventilated. Make sure a power point is nearby.
2. The scooter should be switched off and the key removed.
3. Turn off the mains switch. Never connect or disconnect the charger with the mains turned on.
4. Connect the charger to the charging socket on the tiller (see photograph 1)
5. Once the charger is connected, switch on the mains.
6. The power-on lamp illuminates **red** when switched on. The charger lamp starts **yellow**, changes to **green** when charged. (charge for the full duration 8-12 hours).
7. Switch off the mains and remove the plug from the battery when fully charged. **Do not leave the charger plugged in with the power off. This will discharge your battery.**

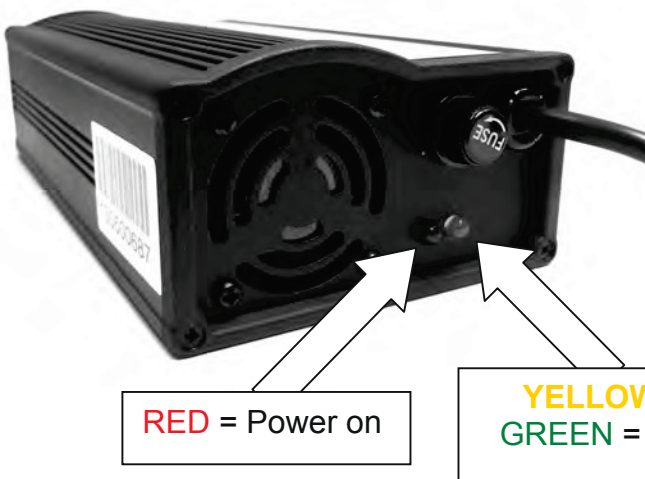
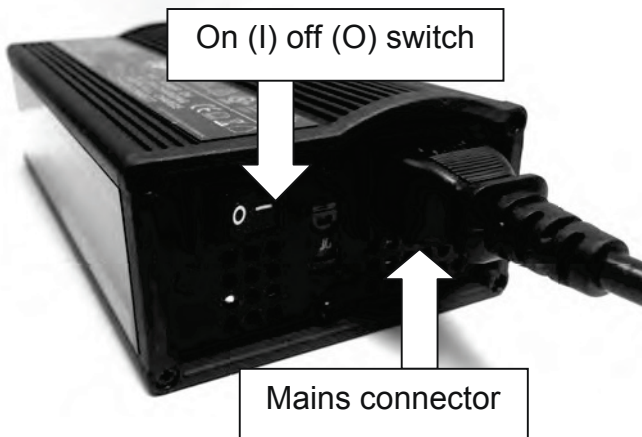

CORRECT CHARGING PROLONGS BATTERY LIFE.

Battery Charger styles can change. If you are not sure of the charging procedure please contact your service provider.

Battery Charging

GENERAL NOTES REGARDING THE BATTERY CHARGER

Battery chargers are subject to regular upgrades. For full instructions read the leaflet supplied with the charger, which can be found in the Battery Charger box.

IMPORTANT

Batteries have a limited guarantee; if they have not been charged correctly and they fail, they will not be replaced under the guarantee. An engineer will be able to detect “misuse or neglect” immediately, so follow the correct charging procedures to prolong their life.

Charging your Batteries.

1. Always use Gel/AGM type batteries as replacements. NEVER use car lead acid batteries. If in doubt ask your Quingo Service Provider.
2. Always use the correct charger. Never use a lead acid (Car type) charger. If the fully charged light does not come on (normally green, varies with charger type) you may have a battery or charger problem.
3. When storing, fully charge the batteries every week - **never let them run low.**
4. Do not leave the ignition on during charging
5. Do not leave the charger switched off with the plug connected to the vehicle. This will discharge the batteries to zero.
6. Charge the batteries in a well ventilated area.
7. Do not charge the batteries in the open air. The battery charger is not waterproof.
8. Always charge the batteries fully after use (normally over night). Do not part charge.
9. As the batteries age they will lose their electrical capacity so the range will decrease.
10. Hilly areas have a great affect on the range. As the motors heat up, they lose their efficiency, increasing demand on the batteries and decreasing the range.
11. If a faulty battery is found it is recommended to change both batteries.
12. If the charger is left on for a long period it will not affect the batteries. The charger is fully automatic and will switch off when the batteries are full. However, if the vehicle is not being used for a long period it is recommended that the charger should be used every week to top up and then disconnect.
13. If the batteries have been discharged for a long period, do not attempt to charge. Contact your service provider for advice.



Caution: If one or both batteries are damaged they could heat up when charging or in an extreme case explode. Ensure that all damaged batteries are disposed of by the supplier.

Daily Check List & Safety Information

Items you should check on a daily/ weekly basis:

Your Daily Check list

1. Visually check the machine for damage, If your tyres are pneumatic, check the tyre pressures (30psi/ 2.1bar)
IMPORTANT POINT: Inflation of your tyres is very important. If they are below the recommended pressure it will affect the tyre wear, steering and range of the vehicle.
2. Check that the steering moves freely.
3. Check the tiller clamp is locked.
4. Check that the seat is located correctly and locked into position.
5. Check the armrests are tight within the width adjustment.
6. Are your batteries fully charged?
7. Is the front and centre baskets secured?
8. Does your accelerator and brakes work correctly?
9. Check for full and free movement of the accelerator lever.

Docking Station

10. Check that all the 6 suction clamps are secured in the Car (4 floor suction clamps, 2 side arm clamps)
11. Check that both front seat supports are secure under the front seats and fully fastened
12. Check the ramps are secured into position

Disposal

- The equipment wrapping is potentially recyclable.
- The metal parts should be used for scrap metal recycling.
- Plastic parts should be used for plastic recycling.
- Electric components and printed circuit boards to be disposed of as electronic scrap.
- Faulty or exhausted batteries can be returned to your supplier for disposal.
- All disposals must be carried out in accordance with the respective national legal provisions. Enquire at your city district council regarding local waste management companies.

Corrosion

All metal parts that are likely to be exposed to the elements are protected from corrosion:-

- Metal parts are plated with zinc/ cadmium passivate coating
- Frame parts have a high impact powder coating
- Plastic covers are formed in UV resistant materials

Important: Possible faults & reporting them to your service provider

When reporting a fault please make sure you have as much information as possible for the service provider (see page 29).

Important Notes when Driving your Vehicle

Driving your vehicle

Whether or not this is your first mobility vehicle, read these guidelines as all vehicles differ. Failure to do this may cause damage to you, a third party or the vehicle.

Check the weather. Make sure you are wearing suitable clothing, regardless if your journey is long or short. (Remember, when it is hot to wear a hat)

If you are taking medication, check with your doctor or physician that your ability to control the vehicle will not be impaired.

- Do not drink & drive it's the law!
- Only use the scooter in accordance with its intended use (see page 4).
- Always stop the scooter on a flat area and always remove the ignition key when it is not in use.
- Do not climb kerbs higher than 7.5cm and always lean forward. When climbing a kerb approach at a slow speed. Do not hit the kerb or an obstacle at speed, as this can cause the front wheel to bounce upwards rendering the vehicle unstable. As you make contact apply power until the vehicle has completed the task. When descending a kerb or obstacle check for traffic and descend slowly until you are on flat ground.
- Do not stop when going up a hill; always lean forward and get to a flat area.
- If you are taking medication check with your doctor or physician that your ability to control the vehicle will not be impaired.
- Do not drive through deep water; transport more than one person; tow other vehicles, drive on rough unpaved ground, soft mud or carry excess weight.
- Do not modify the vehicle as this will invalidate your warranty.
- Make sure the battery charger is disconnected.
- Make sure you have adjusted the seat as instructed in this manual- get comfortable- set the speed control dial to a low setting.
- Switch on the vehicle. Check the battery level indicator is full (6 bars)
- Always place your feet on the footplates.
- To Brake, release the lever. If you become unsure or feel unsafe release the lever immediately.
- As you get accustomed to the vehicle use the power button to increase the speed.

Storage & Cleaning

Read this before driving the vehicle!

Storage and Corrosion Prevention

Always keep your vehicle in a dry area. Do not leave outside in the elements. If you do not have an area to store the vehicle, cover it with a fully waterproof cover.

Cleaning the vehicle

- Only use a damp cloth and gentle detergent
- Do not use any abrasive or scouring liquids
- Do not allow the vehicle near water or in direct contact with water
- Do not use high-pressure cleaning devices

Disinfection

Spray or wipe disinfection using a tested and recognised product is permitted. A list of the current disinfectants is available from the Robert Koch Institute at <http://www.rki.de>. Always wear rubber gloves when using disinfectant and wash your hands thoroughly when finished.

Troubleshooting Guide

This table is a guide to fault finding. The fault may be a simple fix, but if you have any doubts phone your service provider:-

Symptom	Solution
<ul style="list-style-type: none"> • UNIT DOES NOT MOVE. Check: Does the battery level indicator work when the ignition is switched on? 	<ul style="list-style-type: none"> • Freewheel is engaged (check the dash display on page 8) • The Battery is flat– check level
<ul style="list-style-type: none"> • STEERING IS LOOSE OR WOBBLY WHEN DRIVEN. Check: Have you hit a kerb or obstacle hard? Are the handlebars straight when riding in a straight line? 	<ul style="list-style-type: none"> • Check for tyre damage • Damaged steering – contact service provider • Is the seat loose – contact service provider
<ul style="list-style-type: none"> • VEHICLE BEHAVES ERRATICALLY WHEN DRIVEN. Check: Does the vehicle judder or cut out? 	<ul style="list-style-type: none"> • Possible electronic problem - contact service provider. • Binding front wheels • Binding rear wheels – Emergency brake – Switch into freewheel and the vehicle should move easily (if not contact the service provider).
<ul style="list-style-type: none"> • VEHICLE WILL NOT CLIMB OR DESCEND THE DOCKING STATION. Check: Are the wheels slipping? 	<ul style="list-style-type: none"> • The Flyte is fitted with bespoke tyres, these may need replacing. Only fit 'Quingo Flyte ultra-grip rear tyres'.
<ul style="list-style-type: none"> • SHORT RANGE Check: If the red charging lamp stays on after all night charging it may be a defective or worn out battery? 	<ul style="list-style-type: none"> • Check tyre pressures – should be 30psi all round (not the small outer wheels)

Scooter Fault Indicators

There are 3 stages when reporting a fault.

Remember that the Service Provider is there to help you. They will ask you specific questions that need to be answered honestly. This will allow the service engineer to be equipped with the correct part when visiting you.

Before phoning the Service Provider

Check what is wrong with the scooter: If there is a spanner and a number flashing on the tiller display (Page 13) you may be able to correct the problem. The list below shows you which problems you can fix yourself and the others you have to phone the Service Provider for them to fix.

Fault on display

Spanner 1: Battery needs recharging
 Spanner 2: Voltage low
 Spanner 3: Voltage too high
 Spanner 4: Ignition sleep mode
 Spanner 5: Brake fault or freewheel engaged
 Spanner 6: Lever Mechanism fault
 Spanner 7: Speed Pot error
 Spanner 8: Motor error
 Spanner 9: Other error

What to do

Charge the batteries*
 Charge the batteries
 Phone Service Provider
 Turn ignition off, then on
 Check free wheel (Page 12)
 Phone Service Provider
 Phone Service Provider
 Phone Service Provider
 Phone Service Provider

If you phone the service provider, inform them of the number showing on the tiller display.

* Make sure the battery charger is completing its full charge, if not, inform the Service Provider.

Important Note

If you report a problem and there is found to be no genuine fault or the problem is user error you will be charged for the call out, so please check the above first before phoning.

<p>Call Service Provider</p>

Common Questions

How do I clean the vehicle?

- Only use a damp cloth and gentle detergent
- Do not use any abrasive or scouring liquids
- Do not allow water near or direct contact with water
- Do not use high-pressure cleaning devices

I want to modify my scooter, is this ok?

No, any modification will invalidate your warranty. This is because it changes the specification of the product and the manufacturer has to abide by the CE approval marking.

Can I fit weatherproofing such as a canopy?

No, as the Flyte is transportable and is required to be folded to transport, a fixed canopy cannot be fitted.

How long will my batteries last and what range can I expect?

This is a very difficult question and not one that has a straight answer. It depends on many factors but a rough guide to batteries is:

- Keep them charged, do not let the batteries run completely flat. If they are flat charge them up.
- The life of a battery depends upon the number of cycles the battery goes through.
- If you carry out these simple instructions your batteries will have longer life.

Range can be affected by many things such as:

- **Worn batteries:** *As they get older the range decreases*
- **Faulty or worn drive train:** *Uncommon but will be checked by the engineer during service.*
- **Binding brakes:** *If your vehicle is fitted with a front emergency brake is could be sticking, the engineer will check this during service*
- **Low air pressure in the tyres:** *Common fault with low range, always keep the tyre pressures correct*
- **Cold weather:** *Battery performance decreases as the temperature drops*
- **Incorrect charging:** *Part charging will eventually damage the batteries, always fully charge your batteries after use*
- **Weight:** *The heavier the weight carried on the vehicle, the lower the range.*
- **The type of terrain:** *For example if the vehicle is constantly used on grass, shingle or generally soft ground the power consumption doubles. This means your range will decrease by 50%*

Can I leave my scooter outside in the open as I do not have anywhere to store it?

How can I guard against damage or corrosion?

Always keep the vehicle in a dry area. Do not leave it outside in the elements. If you do not have an area to store the vehicle, cover it with a full, waterproof cover.

Reporting a fault and Servicing Information

Breakdown (UK) – Phone 01582 430900

If your vehicle breaks down please do not instruct a 3rd party (a dealer, garage or friend) to fix the problem. Phone the Service Department immediately as failure to do so will invalidate your warranty.

When phoning the Service Department with a fault

Do:

- Please be as clear as possible when explaining your problem (worthwhile writing your problem down before calling)
- Listen to the Service Operators as they will ask you a series of questions. Please answer them as precisely as possible. This helps to determine the problem so the Service Engineer can bring out the correct parts.

Remember:

- When your vehicle is under warranty there are certain situations where it will not be covered such as tyres or damage. Make sure you understand what you are covered by.
- Before you book an engineer for a possible fault make sure there is a problem. If the engineer does not find anything wrong you will be charged for a call out.

Servicing (UK)- Phone 01582 430900

- This vehicle is designed for minimum maintenance but it is essential that a qualified engineer services the vehicle once a year. If the vehicle is used constantly we recommend twice-yearly maintenance.
- Make sure the engineer fills in the handbook on completion for all servicing carried out on your vehicle.
- Keep all receipts for servicing and repairs with this handbook. This may add value if/when selling your vehicle and may be required in the event of a warranty claim.
- On completion of the service, test the vehicle before the engineer leaves and make sure you are satisfied with the work carried out.

Service Check List (for the Quingo Engineer)

(Please Tick Box)

- Check page 27 for fault codes
- Initial diagnostic road test
- Wheel bearings wear and lubricate
- Wheel alignment (3 front wheels), must be a negative toe in 1 to 5 degrees
- Steering and tilting mechanism. Check that it locks under pressure
- Wear or damage to tyres or wheels
- Bodywork fixtures
- Throttle play and adjustment. Check for full and free movement
- Bodywork, wheel clearance, lights secure
- Steering bearing for wear. Check for backwards and forwards movement
- Transaxle mountings are tight
- Handlebar alignment, check for damage
- Motor brush wear
- Motor speed check
- Transaxle play
- Electromagnetic brake operation
- Freewheel operation, Check the fault indicator on the display
- Check brake holding on slope
- Frame for damage, cracks or corrosion
- General corrosion
- All operational controls work correctly
- Battery condition and charger operation
- Tighten all nuts & bolts
- Check tie rod bolts
- Final road test
- Clean vehicle
- Customer road test & sign off

Service Log (For the Quingo Engineer)

1st service
Engineers Name
Engineers Signature

2nd service
Engineers Name
Engineers Signature

3rd service
Engineers Name
Engineers Signature

4th service
Engineers Name
Engineers Signature

5th service
Engineers Name
Engineers Signature

Staple additional pages as required. This page must be filled in. Add additional repairs.

Technical Information Regarding EMI

Important Technical Information regarding Electromagnetic Interference (EMI)

The intensity of interference from electromagnetic energy is measured in volts per metre (v/m), which refers to the strength of the electrical source (voltage) as it relates to the distance away from the object being considered (in metres). Resistance of a scooter/ wheelchair to certain EMI intensity is commonly called “immunity level”.

20 volts/ metre is a generally achievable and a useful immunity level against interference from radio wave sources (the higher the immunity level, the greater protection).

Your scooter had been tested and found to meet the required immunity level from Electromagnetic Interference (20v/m): the intensity of interference from electromagnetic energy.



Caution: Even with the immunity level of 20 volts per meter, certain precautions must be followed to ensure your scooter/ wheelchair will not be affected by outside electromagnetic sources.

See Page 5 of this manual for additional information.

Guarantee & Warranty

Warranty Statement. Important information for the owner

The period of warranty varies from country to country ranging from 1 year to 3 years. Please see your purchase order for full details.

In accordance with the warranty conditions for new vehicles the warranty is active from the date of delivery.

1. Should any part of the vehicle require repair or replacement as a result of a specific manufacturing or material defect within the warranty period from the date on which possession of the vehicle was transferred to the original purchaser and subject to it remaining within that ownership, the part or parts will be repaired or replaced free of charge if the vehicle is returned to the seller.
2. Any repaired or replaced part will benefit from any arrangements for the balance of the warranty period remaining.
3. Items of a consumable nature, tyres, tubes, motor brushes, bulbs, batteries, upholstery will not be covered during the warranty period, unless such items have clearly suffered undue wear as a direct result of an original manufacturing defect.
4. Batteries are covered against a specific manufacturing or material defect. Batteries are consumable items and any battery requiring replacement during the warranty period due to normal use will not be considered defective and therefore not replaced free of charge. Batteries found to be damaged due to incorrect charging or maintenance will not be covered by the warranty.
5. To apply the warranty conditions should your vehicle require attention, under these arrangements, notify Quingo's UK Authorised service provider Forever Active immediately, giving full information about the nature of the defect. Forever Active will arrange for work under the warranty conditions to be carried out by an authorised Forever Active engineer.
6. No responsibility will be accepted for repairs or replacements arising as a result of:
 - a. The vehicle or part not being maintained in accordance with the manufacturers recommendations.
 - b. The vehicle or part having been damaged by neglect, accident, overloading, mis-use or the vehicle being used in a manner which exceeds the designed parameters.
 - c. The vehicle or parts having been altered from the manufacturer's specification or repairs carried out by an unauthorised repairer.
 - d. The vehicle is part fitted with unauthorised extras or alterations to the design.
 - e. Any repairs or servicing carried out by unauthorised engineers.

The vehicle should be serviced at least once over a 12-month period. If you are a hard user we recommend a twice-yearly service. If your warranty is greater than one year a once yearly service is mandatory.

Failure to service your vehicle annually will invalidate your warranty.

The warranty is offered in addition to and does not detract from the contractible rights you have under statute or common law.

Quingo Flyte & Docking Station Technical Specification

Flyte

Class Type	Classified according to EN12184 as class B mobility unit
Speed	6kph (4mph)
Length (without basket)	110cm (43.3")
Length (with basket)	126cm (49.6")
Width	59cm (23.2")
Height (ground to top of seat)	101cm (39.8")
Height (ground to top of tiller)	105cm (41.4")
Height (transportation/ folded)	51.5cm (20.3")
Wheelbase	77cm (30.3")
Seat Width (between armrest)	43-58.5cm (16.9-23")
Seat Depth Actual	38cm (15")
Seat Depth to ISO 7176.7	28cm (11")
Backrest Height	36cm (14.2")
Seat height (from ground level)	71cm (30")
Total Unladen Weight	116.5Kg (256lbs)
Weight of each battery	6Kg
Tyre type/ Pressure	Pneumatic/ pressure 30psi/ 2.1bar
Motor	250-watt 2-pole
Battery Capacity Quingo	12V 22Ah x 4 off (6 off optional)
Maximum Carrying Capacity	160Kg (25.0st) (352lbs)
Range (standard 4 batteries)	37Km (23miles) see notes regarding range
Range (optional 6 batteries)	54Km (34miles) see notes regarding range
Turning Radius	102cm (40.2")
Safe climbing angle	6 degrees
Maximum loading angle	30 degrees
Kerb Climbing	7.5cm (3") *

Docking Station

Overall Weight (must be lifted in sections)	37.9Kg (83.6lbs)
Side Ramp Weight (each side)	12.6Kg (27.8lbs)
Centre Ramp Weight	2.7Kg (6lbs)
Frame Weight (including side support arms)	10Kg (22lbs)
Overall Length (with supports)	135cm (53.2")
Folded Length	123cm (48.5")
Overall Width	77cm (30.3")
Height	19cm (7.5")

*Measured as a safe maximum kerb height

Note on range: To measure accurately, the range of the vehicle is an estimate based on the following:

- New batteries
- Ambient temperature during test @ 60 degrees
- A 100Kg/16st/220lb person loaded on the vehicle
- Flat ground test with stop/ start (average motor loading)

Quingo Flyte & Docking Station Technical Specification

Range: Up to 23 miles (37km) with standard battery configuration.

The range can be increased up to 34 miles (54km) with the optional 2 x 22Ah batteries which can be fitted into the rear lockable box.

The above range figures are theoretical, produced in accordance with ISO 7176-4. ISO 7176-4 specifies a method for determining the theoretical distance range of electrically powered wheelchairs and scooters by measuring energy consumed over a specified distance. It is applicable to electrically powered wheelchairs and scooters with a maximum speed not greater than 15 km/h, intended to provide indoor and/or outdoor mobility for one disabled person whose mass is within the range presented by ISO 7176-11.

The distance range of an electrically powered wheelchair is affected by energy consumption and battery condition. Energy consumption is affected by a number of factors such as ambient temperature, total weight and weight distribution of the user, topography, surface characteristics, and tyres. Battery condition is affected by factors such as temperature, age, charging history and discharging history. Hence the result obtained from the test specified in this part of ISO 7176-4 cannot be used to derive an accurate range estimate for a particular wheelchair (or scooter) and user. However, it can be used to give a basis for comparison between different wheelchairs or scooters under similar test conditions.

Note regarding speed: The maximum speed and performance criteria are set as per specification and cannot be changed in any way by the customer. This can only be changed by a qualified engineer equipped with a suitable electronic programmer.

Note: Specifications are correct when going to press. Advanced Vehicle Concepts Ltd retains the right to change specifications without prior notice.



Part 2

Quingo Docking Station.

How to 'load the Quingo Flyte

The Quingo Flyte and Docking Station is a unique product to the mobility market. It is essential to have a full understanding of how the product works, with its ease of use and that no lifting of heavy scooter parts are required.

The Step-by-step guide will allow you to have a good understanding of how easy this product is to operate with minimal effort. It is important that you understand the complete operation before use (please refer to the DVD that comes with the handbook for visual aids).

Step 1- Park your car appropriately.

- a) Always park your car on a hard, flat surface.



- b) Apply the handbrake.



- c) Allow 3 metres (10ft) of space behind your car for loading & unloading.

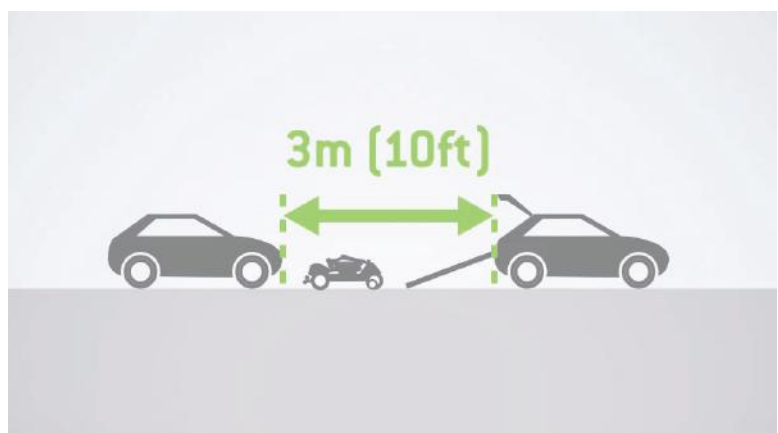

Step 2- Slide out the docking station ramps.

- a) Fully lift your tailgate.

The Docking Station will be fully assembled and secured in position by your engineer, you should still carry out a few safety checks yourself on a daily basis to ensure the Docking Station is still secure.



- b) Release the locking latch and at the same time, slowly pull the ramps approximately 5cm or 2 inches away from the docking station.

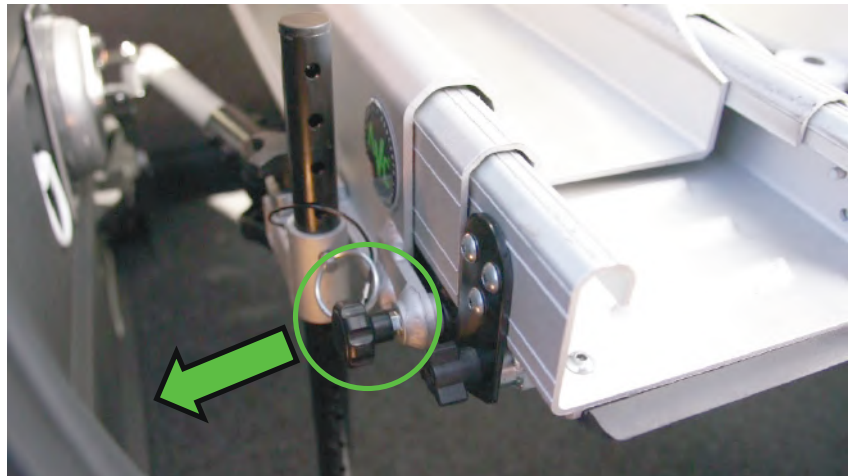

- c) Now grip both the left and right green ramp handles and fully extend the ramps. Two sets of OK labels will be displayed when fully extended. Lower the ramps to the floor- you can use the assisting cane to avoid bending (see page 39).



ALWAYS use both hands to hold the green handles when sliding the ramp sections in and out.

Step 2- (c)

Photograph to show the ramps being lowered using the assisting Cane.



- d) Check that the ramp maximum angle indicator is showing green only and is not in the red (which indicates the angle is too steep)



Step 3- Position and prepare the Flyte for loading.

- a) Position the Flyte to the centre ramp using the front bumper alignment arrows and stop the Flyte before making contact with the ramp.

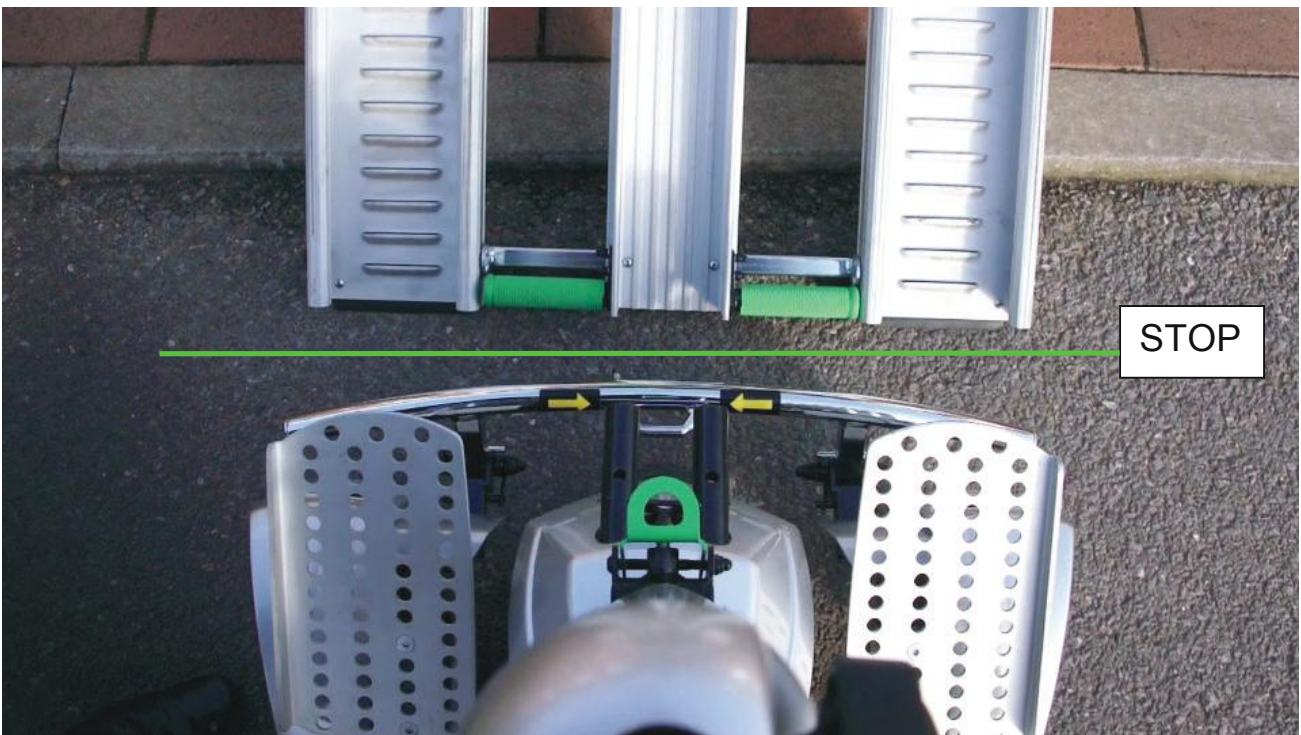
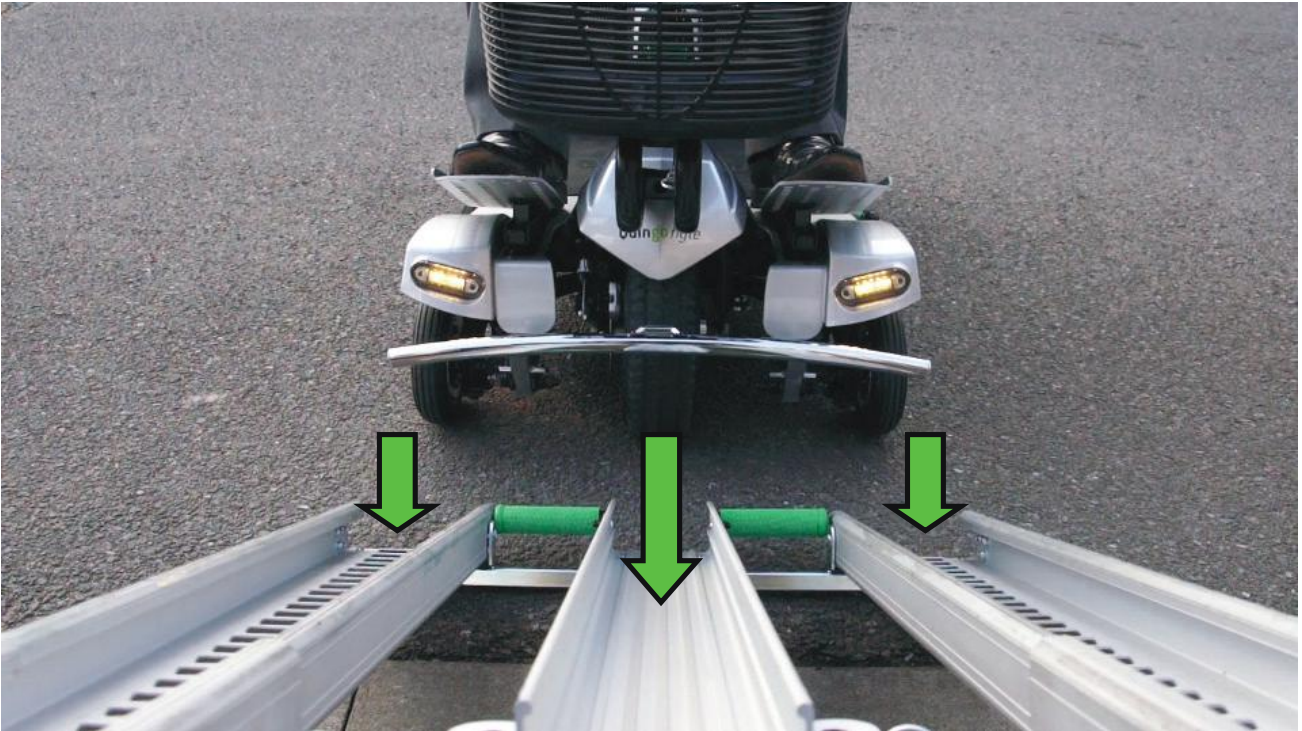

The 2 Yellow Arrow stickers can be seen from your seated position. Please note these are only to be used as a guide, caution must be taken when approaching the Docking Station. **DO NOT DRIVE UP THE RAMP.**

Step 3.

- b) Ensure that the seat is pushed back to its furthest position (the Flyte will become more compact and provide more clearance when being transported)

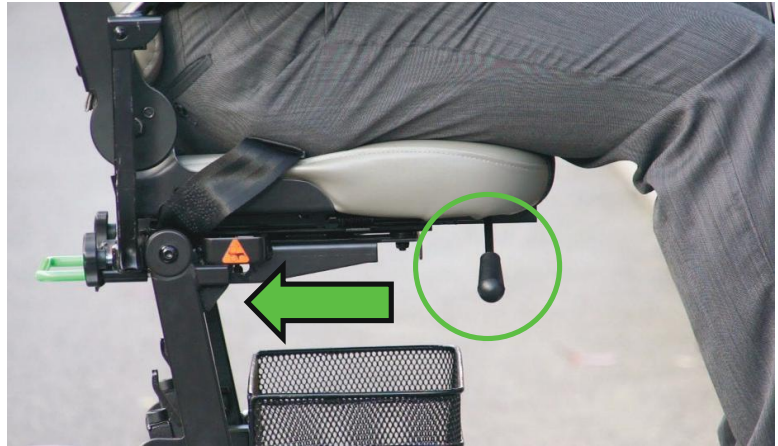

- c) Remove the key from the ignition.



- d) Remove the front basket by releasing the locking pin.



The centre basket is removed by pulling away from the magnetic retainers.



Step 3

- e) Release the armrest thumb screws and remove both armrests. Place these items underneath or to the side of the docking station; ensure they do not obstruct the ramps.



Step 4- The Flyte folding sequence.

A Useful Tip - Try and let the product do the work; do not force any parts throughout the folding process.

- a) Fold the back support down flat.



Step 4.

- b) Push the green seat release lever and tilt the front of the seat upwards and over until the seat unlocks for folding.



- c) Now push the seat assembly forward where it will lower the Flyte's deck.



- d) Release the Tiller locking lever and lower the tiller onto the seat's velcro fastening.



The Flyte is now fully folded.

A Useful Tip - Practise folding and unfolding the Flyte numerous times to get familiar with the above steps.

Step 5- Engage the 'Flyte-mode' levers.

For the following step, you may choose to use the 'Assisting Cane' to avoid unnecessary bending if you require.

- a) The rear green lever must be set to Flyte mode. Push down on the lever, the rear and front lights will now flash rapidly - Rapid flashing means another step is necessary.

WITHOUT 'ASSISTING CANE'



WITH 'ASSISTING CANE'



The 2 photographs below are to show the position of the lights which flash when you activate the rear lever to Flyte mode.



Step 5

- b) Next pull the side lever up to the red 'Flyte Mode' position; the lights should now flash once a second - the Flyte is now ready to load. If the lights flash at a high speed you have 1 further operation, repeat step 5.

WITHOUT 'ASSISTING CANE'

WITH 'ASSISTING CANE'

Step 6- Using the remote to load the Flyte.

- a) Use the ignition key to unlock the remote from the rear lockable box.



Step 6.

- b) Ensure the remote cable is full extended and tangle free, be careful not to trap or pull on the cable.



- c) For your safety, never stand directly behind the vehicle. It is very important to stand to one side of the ramps before loading.



- d) Press the silver 'UP' button continuously until the Flyte is fully inside the car where it will automatically power down.



- e) Replace the remote into the lockable box.



NEVER stand directly behind the vehicle. It is very important to stand to one side of the ramps before loading.
Keep the remote control away from water. When finished with the remote place in the lockable box.

Step 7- Return the ramps to the docking station.

For the following step, you may choose to use the 'Assisting Cane' to avoid any unnecessary bending.

- a) Lift the green grips of the ramps to bring them horizontal. (Place the cane in the centre ramp and hold both green handles)



- b) Slowly walk the ramps towards the car until the locking latch engages. Check the ramps are secure and close the tailgate.



Note: The ramps should not pull outwards when locked.

- c) Check the ramps are secure and close the tailgate.

Note: The ramps should not pull outwards when locked.



Do not activate the guide roller levers once the Flyte has been loaded onto the Docking Station.



How to 'Unload' the Quingo Flyte

The Quingo Flyte and Docking Station is a unique product to the mobility market. It is essential to have a full understanding of how the product works, with its ease of use and that no lifting of heavy scooter parts is required.

The Step-by-step guide will allow you to have a good understanding of how easy this product is to operate with minimal effort. It is important that you understand the complete operation before use (please refer to the DVD that comes with the handbook for visual aids).

Step 1- Park your car appropriately.

- a) Always park your car on a hard, flat surface.



- b) Apply the handbrake.



- c) Allow 3 metres (10ft) of space behind your car for loading & unloading.

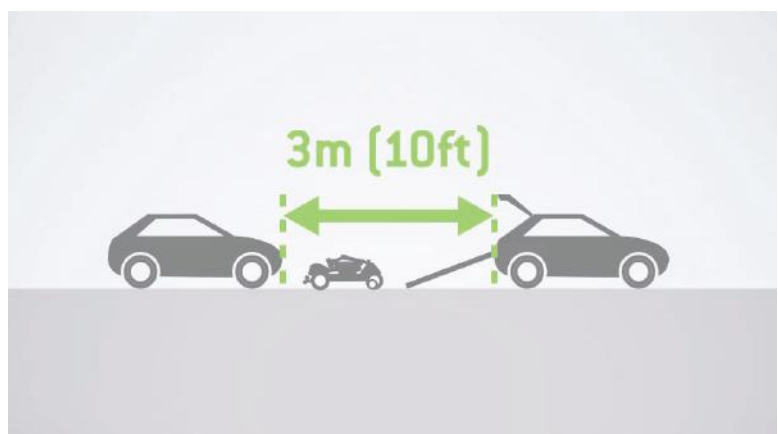

Step 2.

a) Fully lift your tailgate.

The Docking Station will be fully assembled and secured in position by your engineer, you should still carry out a few safety checks yourself on a daily basis to ensure the Docking Station is still secure.



b) Release the locking latch and at the same time, slowly pull the ramps approximately 5cm or 2 inches away from the Docking Station.



c) Now grip both the left and right green ramp handles and fully extend the ramps. Two sets of OK labels will be displayed when fully extended.



When lowering the ramp sections to the floor you can use the 'assisting cane' to avoid bending over (see page 39).



ALWAYS use both hands to hold the green handles when sliding the ramp sections in and out.

Step 2.

- d) Check that the ramp maximum angle indicator is showing green only and is not in the red (which indicates the angle is too steep)



Step 3.

- a) Use the ignition key to unlock the remote from the rear lockable box.



Step 3.

- b) Ensure the remote cable is full extended and tangle free, be careful to not trap or pull on the cable.
- c) For your safety, never stand directly behind the vehicle. It is very important to stand to one side of the ramps before loading.



- d) Press the silver 'DOWN' button continuously until the Flyte is fully clear of the ramps. Allow 1 meter of space between the Flyte and the ramps.



NEVER stand directly behind the vehicle. It is very important to stand to one side of the ramps before unloading.

Keep the remote control away from water. Place the remote control in the lockable box when you have finished the manoeuvre.

Step 3.

- e) Replace the remote into the lockable box. The lights on the scooter should be flashing with a 1 second interval, this is normal.



Step 4- Return the ramps to the docking station.

For the following step, you may choose to use the 'Assisting Cane' to avoid unnecessary bending.

- a) Lift the green grips of the ramps to bring them horizontal. (Place the cane in the centre ramp and hold both green handles)



Step 4.

- b) Slowly walk the ramps towards the car until the locking latch engages. Check the ramps are secure.

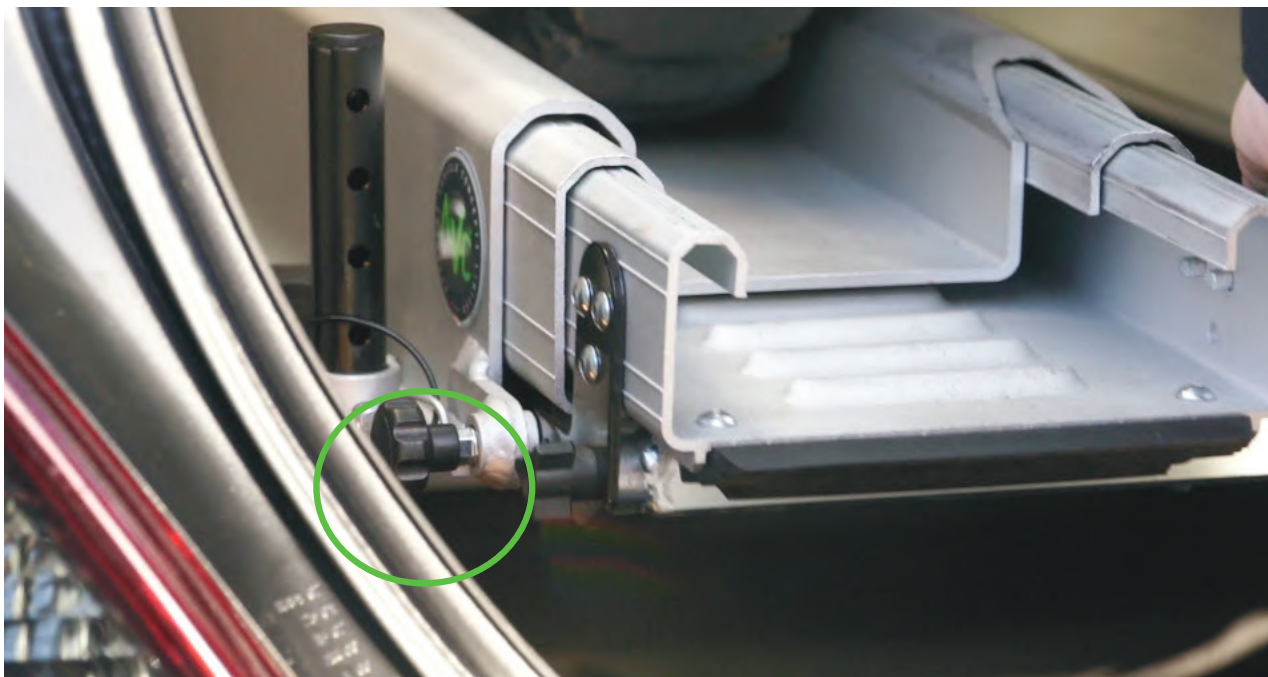

Step 5- The Flyte Unfolding Sequence.

- a) Release the Tiller from the velcro fastening and lift the Tiller until it locks into position.



Step 5.

- b) Now lift the seat assembly upwards keeping the seat base level until it locks into place.



You MUST check the seat is fully located and locked into position. (You may wish to use the Assisting Cane to avoid bending when lifting the seat)



- c) Lift the back support into driving position.



Step 6- Disengage the 'Flyte mode' levers.

For the following step, you may choose to use the 'Assisting Cane' to avoid unnecessary bending.

- a) The rear green lever must be set to 'Drive' mode. Pull the lever up, the rear and front lights will now flash rapidly - Rapid flashing means another step is necessary.

WITHOUT 'ASSISTING CANE'

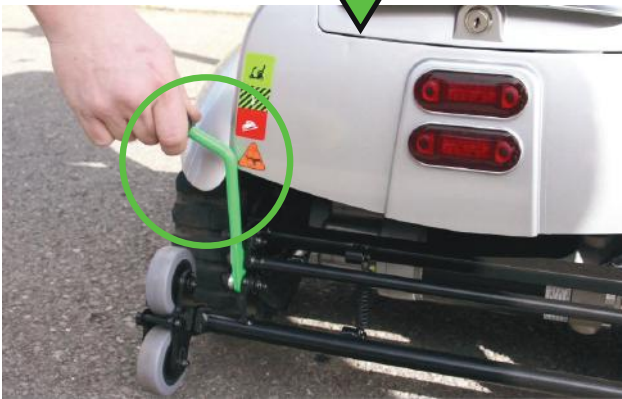
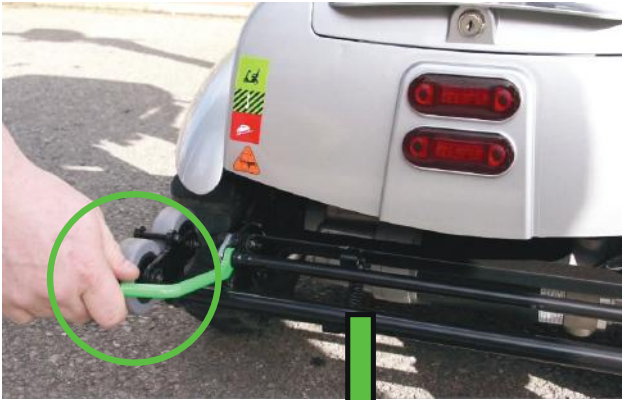

WITH 'ASSISTING CANE'



The 2 photographs below are to show the position of the lights which flash when you activate the rear lever to 'drive mode'.



Step 6.

- b) Next push the side lever forward to the green 'Drive' position; the lights should now go out.

WITHOUT 'ASSISTING CANE'



WITH 'ASSISTING CANE'

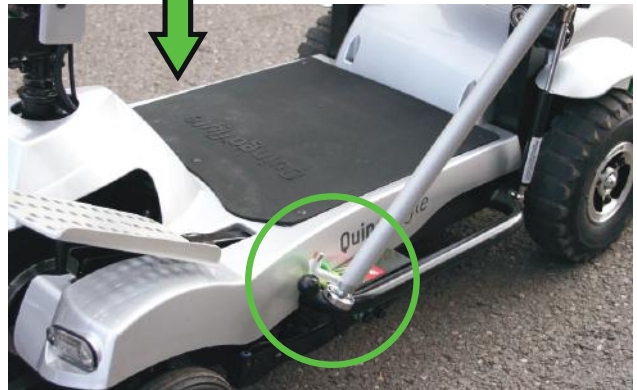

Step 7- Prepare Flyte for 'Drive mode'

- a) Attach the front basket with the locking pin.



Step 7- Prepare Flyte for 'Drive mode'

- a) Attach the centre basket to its magnetic retainers.



Step 7.

- b) Attach the armrests and tighten them using the thumb screws.



- c) Return assisting cane to the car and close the tailgate.



- d) Return the key to the ignition switch and your Quingo Flyte is now ready to drive.



How to Install the Quingo Docking Station

Lifting Caution Heavy Components: We advise you to seek assistance when lifting Docking Station components. It is highly recommended that the accompanying DVD is viewed prior to fitting.

It is essential the Docking Station is fitted safely.

Step 1- Preparing the Car for Installation.

- a) Clear the car of all articles and obstructions and ensure it is free of grit and dirt.
- b) Remove the back parcel shelf and fold the rear seats as flat as possible. (Headrests may need to be removed)



- c) Adjust the front passenger and driver seat sliders to a comfortable driving position. These must not be moved, once set. Note: The backrest angle can be adjusted at any time.



Step 2- Positioning the Frame Within the Car.

- a) Position the Docking Station frame into the back of the car. The rear stop bar should be located against the car's boot lip and should be be centred left and right.



Step 3- Engage the leg support suction clamps.

- a) Place the 4 base plates under each of the suction clamps, making sure the complete suction clamps are on the plate. Once in position push down on each suction clamp to secure the clamps of the Docking Station to the base plates.

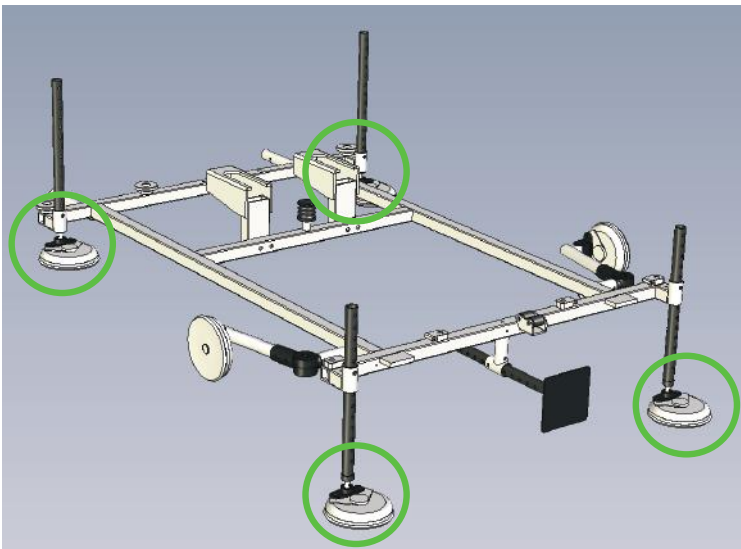

Step 4- Adjusting the lateral support arms.

- a) Attach and activate the two remaining base plates to the lateral support arms, making sure the complete suction clamps are on the plate. Loosen the thumb screws on each of the support arms and manoeuvre them into position so that they are pressed against the base plate, and then tighten the thumb screw.

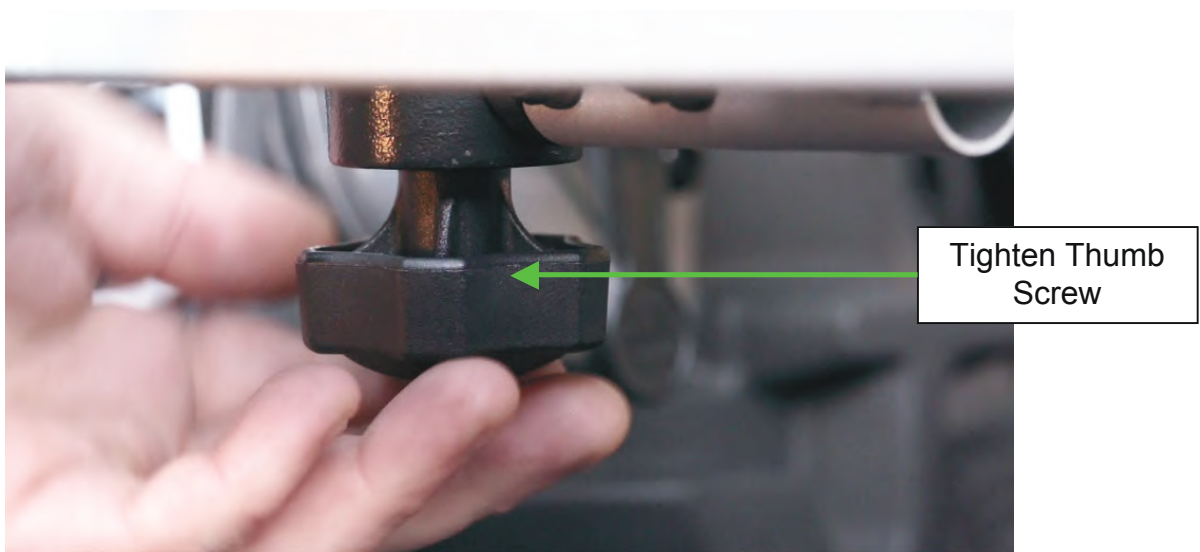

Step 5 - Adjusting the Front Seat Support Arms.

- a) Tilt the cars backrests forward. Do not move the forward/ rear adjustment once this is set.
- b) Attach each of the front seat-support arms to the Docking Station frame and secure with the locking pins.



- c) Loosen the thumbscrews and adjust the angle of the arms so the plates locate under the base of the front seats. Re-tighten the thumb screws. The angle set should allow the seat-back to return to a normal driving position.

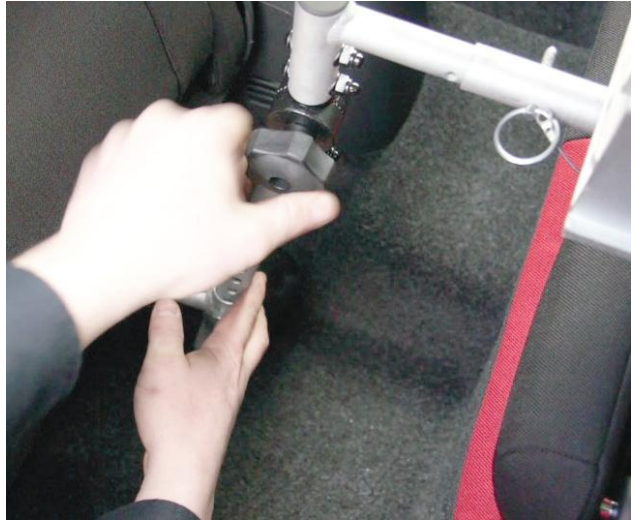

It is very important the support arms are adjusted correctly and fully secured into position. Ensure all 6 suction cups are located correctly. These items must be checked daily before the car is driven.

Step 6- Fitting the Left & Right Ramp Assemblies.

(Caution: When lifting ramp assemblies always carry them horizontally to avoid the ramps from sliding out unexpectedly) - Read the Warning Label

- a) Identify the left ramp assembly which has the box section as circled below. Slide this ramp assembly onto the Docking Station frame and under the locating discs so that the yellow arrows are aligned.



Step 6.

- b) Loosen the 2 left hand thumbscrews and twist the holding brackets through 90 degrees. Tighten the thumbscrews to secure.



- c) Next, slide the right ramp assembly onto the Docking Station frame and under the locating discs and again so that the yellow arrows are aligned. Loosen the 2 left hand thumbscrews and twist the holding brackets through 90 degrees. Tighten the thumbscrews to secure. Use the photographs in step a) and b) to assist with the fastenings on the right hand ramp assembly.



Caution: Ramp extending during fitting/ removal.

When fitting or removing the ramps to and from the base frame use extreme caution at all times.

Place one hand over the end of the ramp that extends outwards and hold the assembly horizontal as it may extend during removal.

Step 7- Fitting the centre ramp assembly & check.

- a) To fit the centre ramp assembly first slide both ramps out so they are clear of the vehicle.



- b) Pick up the guide roller assembly (a) and with the arrow facing towards the car position the roller assembly between the left and right ramp assembly.

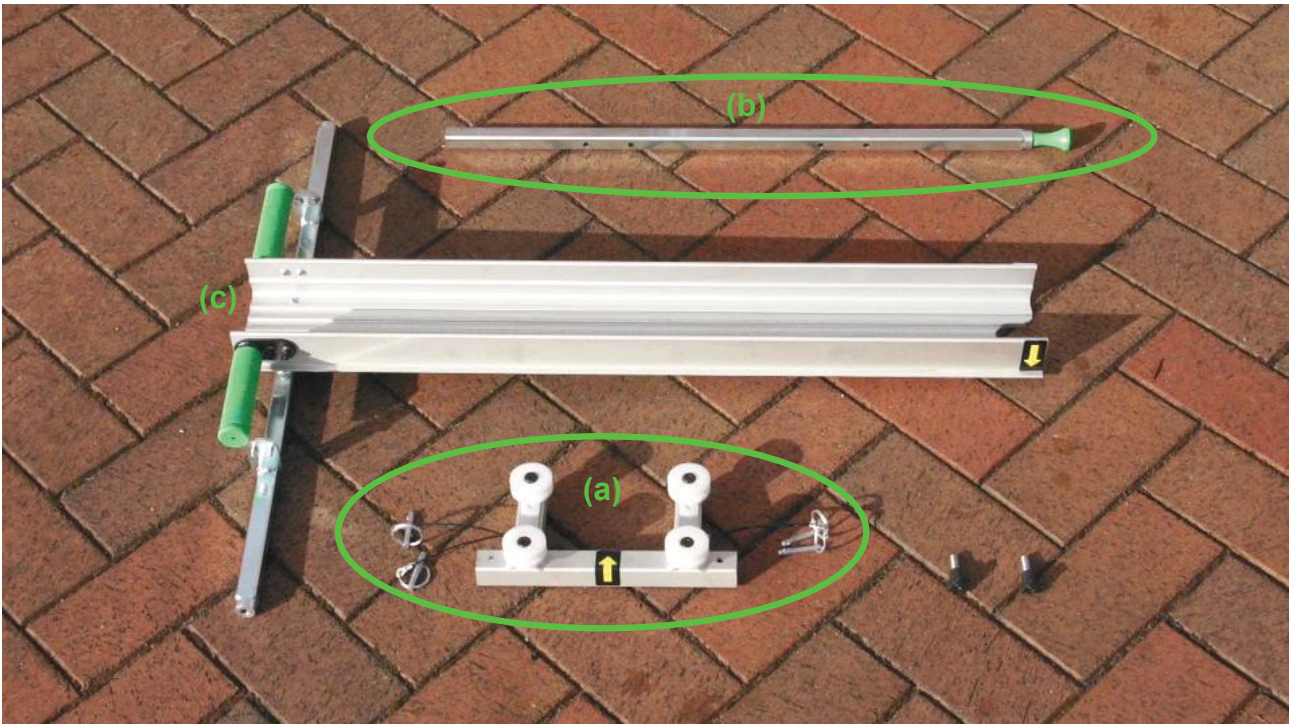

- c) Next insert the guide support bar (b) with the holes facing up, through all 3 components (guide roller assembly and the left and right hand ramps) until all are held together.

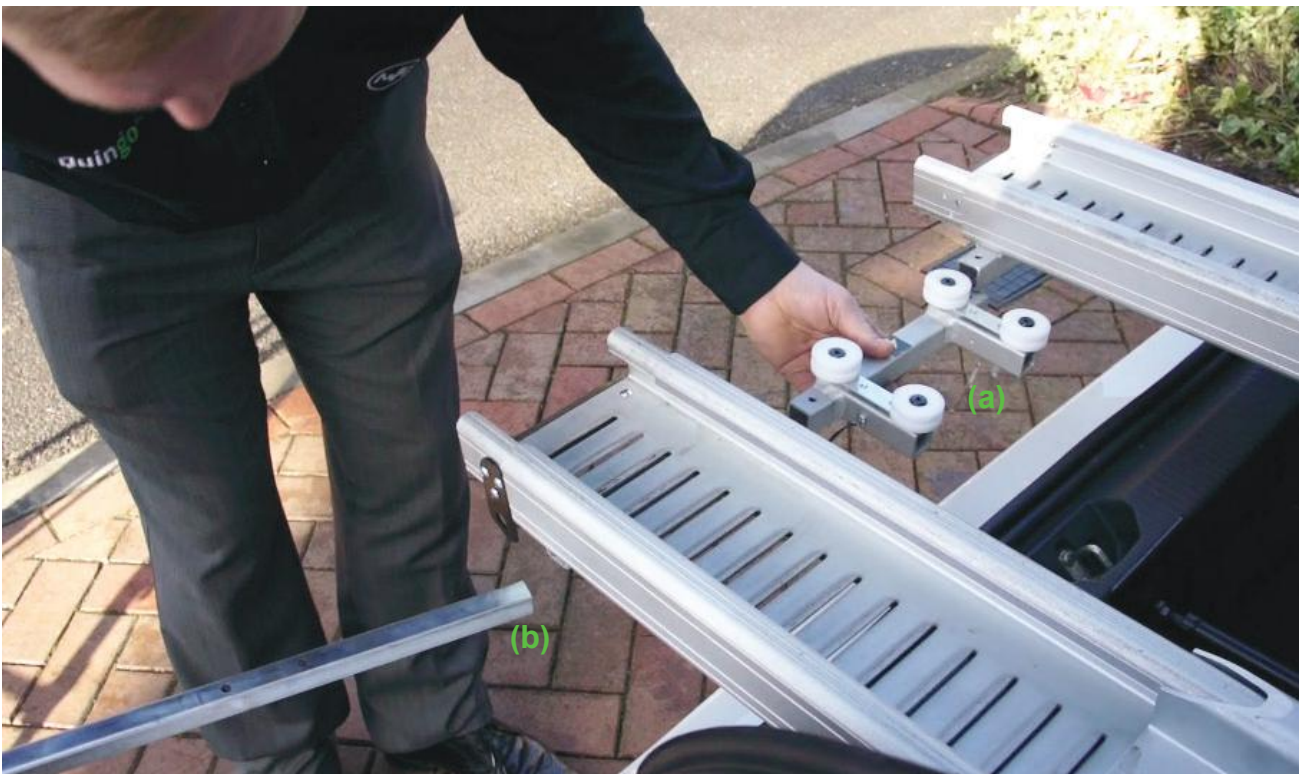

- d) Ensure all 4 locating holes line-up and insert the 4 locating pins to secure the ramps into position.



- e) Next insert the central ramp (c) between the 2 sets of white rollers so that the end of the ramp is 2.5cm (1") past the second set.



- f) Pull the left and right ramps out to meet the centre ramp (c) and locate the double pins into their respective holes (as circled).



- g) Tighten the mini thumbscrews, fully; ensuring the body of the thumbscrew locates through the bracket.

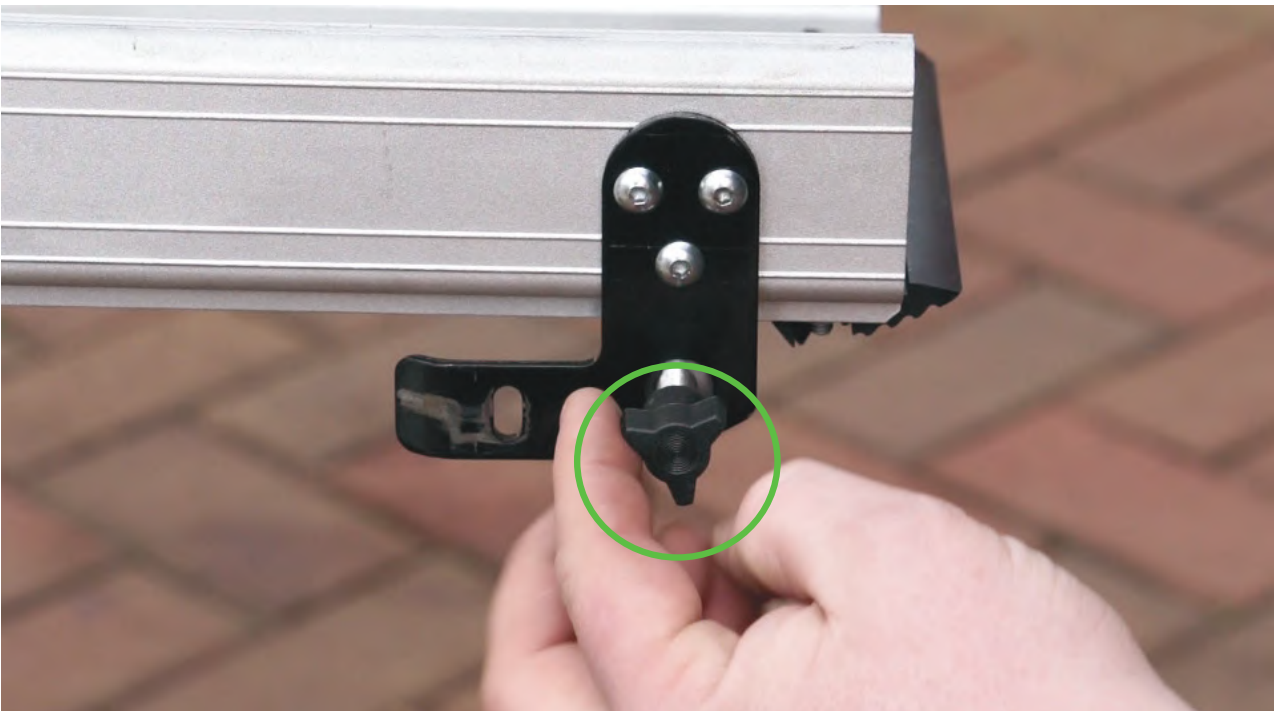

- h) Finally check that the Docking Station ramps operate correctly.



It is important that the small thumb screws are fully fastened into the bracket on each side (this includes the shoulder of the thumb screw).

How to Remove the Quingo Docking Station

Lifting caution: We advise you to seek assistance when lifting Docking Station components.

Step 1- Removing the Centre Ramp Assembly.

a) Pull the ramps out of the Docking Station halfway



b) Remove the mini thumbscrews from the end of the ramps

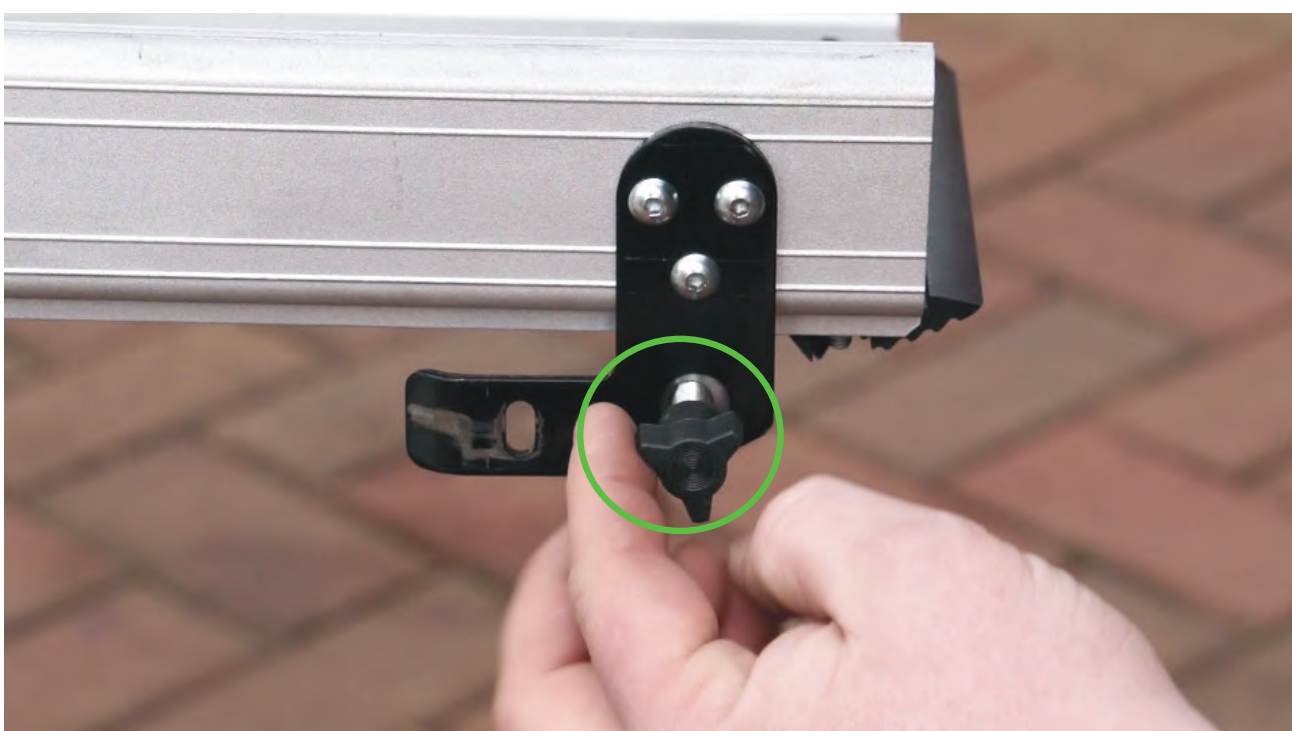

c) Pull the left and right ramps outwards to slide out the centre ramp.



d) Pull the ramps away from the vehicle further so the centre bar can slide out freely.



e) Release the guide roller assembly locating pins. and slide out the guide roller bar.



f) Slide out the guide roller bar.



Step 2- Remove the Left/ Right Ramp Assemblies.

a) Push the ramps back fully into the Docking Station as photograph below.



Step 2 - continued

- b) Loosen the ramps thumb screws and twist the holding brackets through 90 degrees to release both the ramp assemblies.



- c) Slide the left and right ramp assemblies away from the Docking Station frame.



Caution: Ramp extending during fitting/ removal.
When fitting or removing the ramps to and from the base frame use extreme caution at all times.
Place one hand over the end of the ramp that extends outwards and hold the assembly horizontal as it may extend during removal.

Step 3- Remove the Front Seat Support Arms.

- a) Tilt the cars backrests forward.
- b) Loosen the thumb screws to release the front seat support arms, remove the locking pins and detach the arms from the Docking Station frame.

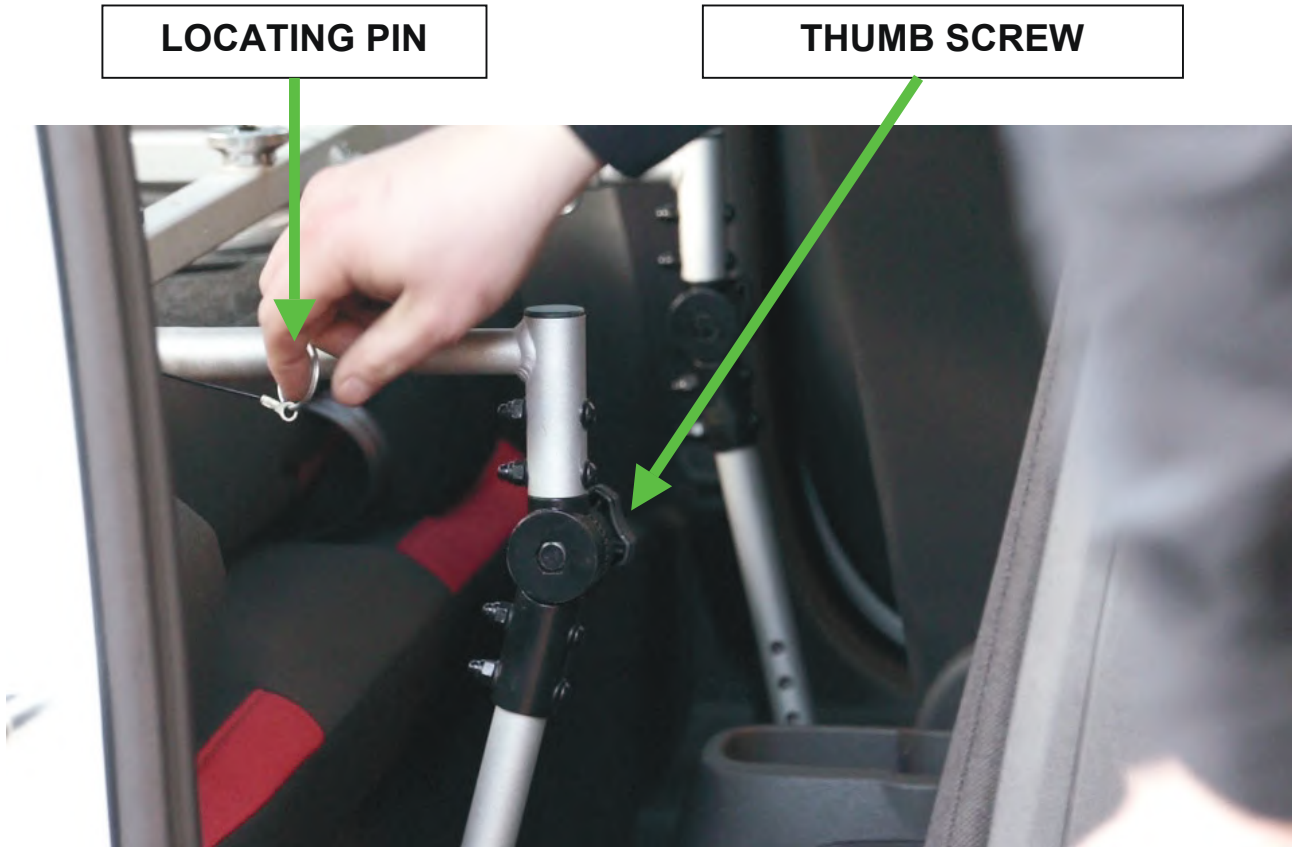

Step 4-Loosen the lateral support arms.

- a) Release the suction clamps from both lateral support arms.
- b) Loosen the thumb screws on each of the support arms and manoeuvre them back towards the frame, and then tighten the thumb screws. You may optionally remove the base plates or leave them fixed to the car for next time.



Step 5- Release the Leg Support Suction Clamps.

- a) Release each of the suction clamps on the 4 leg supports. You may optionally remove the base plates or leave them fixed to the car for next time.



Step 6- Remove the Frame from Within the Car.

- a) Carefully lift and remove the Docking Station frame from the car.



Step 7- Pack and Store the Docking Station.

- a) Store all Docking Station components in a dry dust free environment.

If you are unsure of any of the procedures in this handbook or on the DVD please contact your service provider.

Additional Information for the Noise reduction wedges.

The Quingo Docking Station is supplied with some noise reduction wedges. You can place 4 off wedges in the docking station, as indicated below, which will reduce the noise when travelling.

2 off wedges are to be placed at the boot end of the Docking station between the ramps.

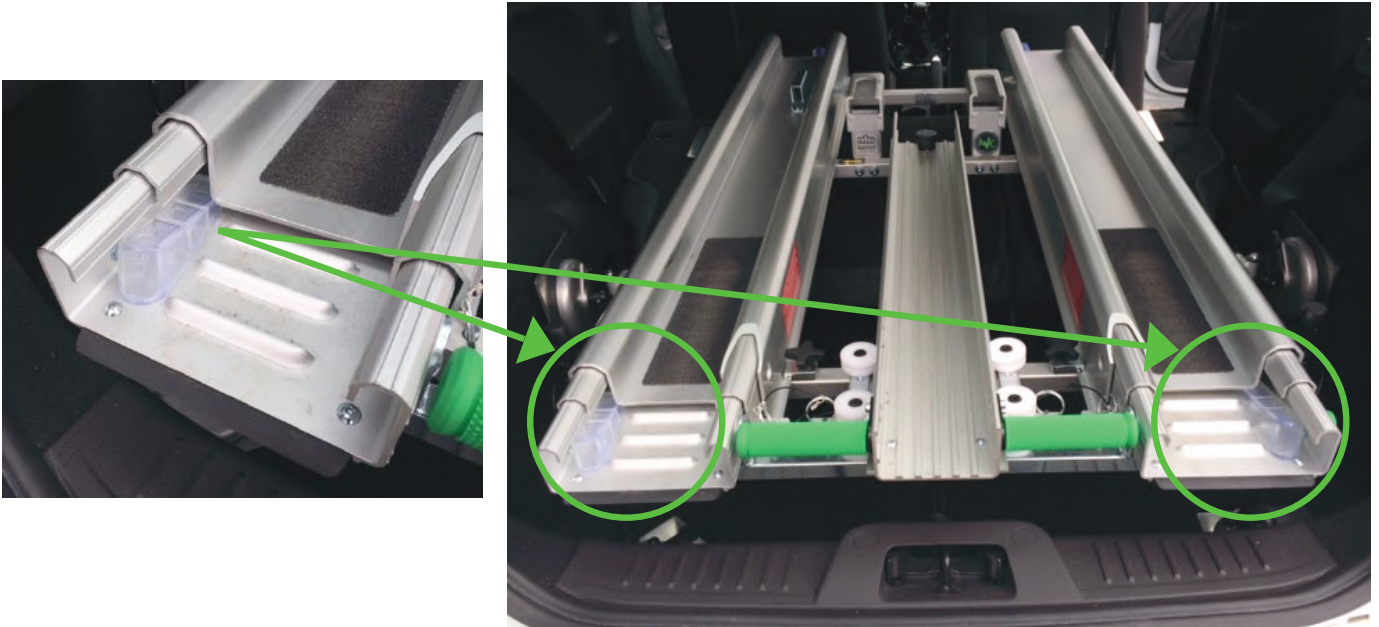

2 off wedges are to be placed at the front seat end of the Docking station between the ramps and carriage section.

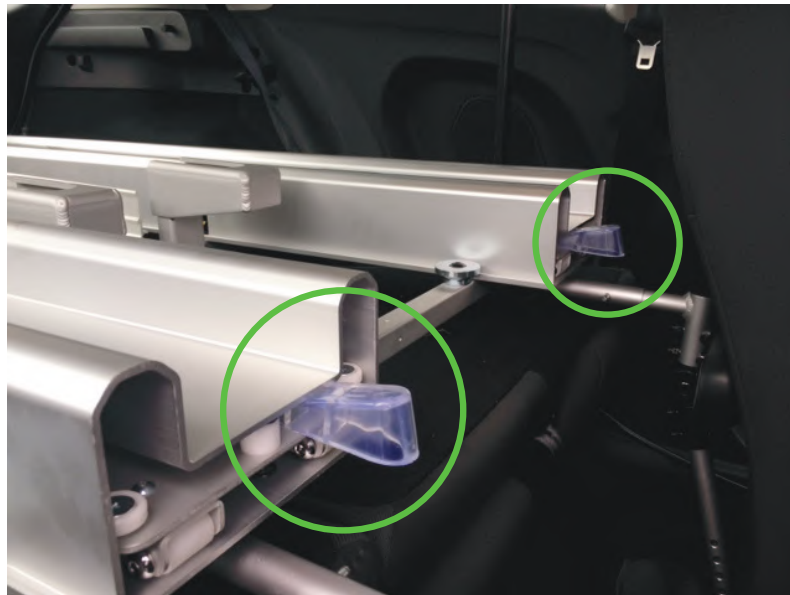

Please Note:-

The Noise reduction wedges must be removed before loading and unloading the Flyte onto the Docking Station to prevent the ramps from becoming stuck and not closing completely.

All Suction Clamp fittings, Seat Support Clamps & Thumb Screws to be checked daily for security.

Quingo Flyte & Docking Station

USER GUIDE DVD

For Customer Services call:

01582 430900

