

STORZ HYDRANT CONVERTERS



Specifications

Storz Hydrant Converter: SZMC Low Profile, Hydrant Nut Cap Hardcoat Anodized

5" Storz Metal Face X 4 1/2" NH Female, (3) Set Screws, Hi-visibility Reflective Tape, With Low Profile Hydrant Nut Storz Cap
 PART #: SZMC5045-3

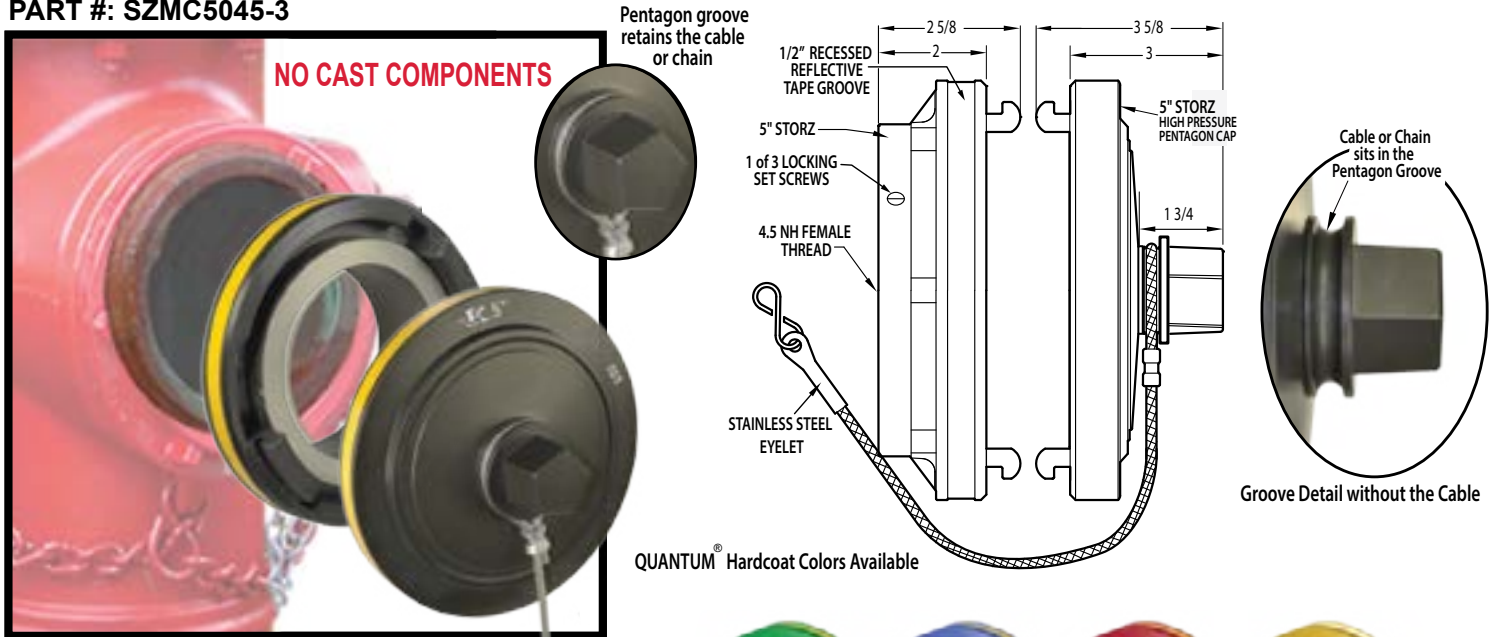

FEATURES:

- Aluminum Alloy 6061-T6 extruded forging only.
- (3) Stainless steel set screws for mounting.
- The converter is hard anodized aluminum metal face seal and hard anodized aluminum Storz ramp and lugs.
- The NH thread female adapter contains a flat rubber gasket which seals against the male hydrant nozzle.
- The head has a 1/2" relief machine cut around the outside creating a recess for the insertion of highly visible yellow reflective tape.

STORZ CAP AND CABLE CONSTRUCTION:

- **ASSEMBLY:** Both the center cap and the outer ring containing the Storz ramps and lugs is Aluminum alloy 6061-T6 forged extrusion. The outer ring has a 1/2" wide relief machine cut around the outside creating a recess for the insertion of the reflective tape. The cap has a high torque Hydrant Nut and can be removed with a Standard Hydrant Wrench.
- **CABLE:** 3/32", (7 x 7) Stainless steel aircraft cable w/ stainless steel eyelet end is supplied with the cap.
- **GASKETS:** Commercial grade neoprene and molded SBR rubber
- **SCREWS:** 304 stainless steel socket head screws.
- **FINISH:** All parts are aluminum. Storz Assembly is Hardcoat Anodized meeting Mil-A-8625-F, dark grey, Type III, Class I spec. Color is available with our Quantum® Hardcoat Anodizing which meets Mil spec 8625 Type III Class II
- **ALL COMPONENTS:** Meet or Exceed NFPA Specifications
- **REFLECTIVE TAPE:** Commercial grade reflective urethane film, LS-300c Refl 1, class 1, FP85 type 2, AFTM d4956-94 type 1, 7 year durability, 5.5 mil thickness

Specifications

Storz Hydrant Converter: SZMC Low Profile, Hydrant Nut Cap

Micalox® Hardcoat Anodized

5" Storz Metal Face X 4 1/2" NH Female, (3) Set Screws, Hi-visibility Reflective Tape, With Low Profile Hydrant Nut Storz Cap

PART #: SZMC5045-3

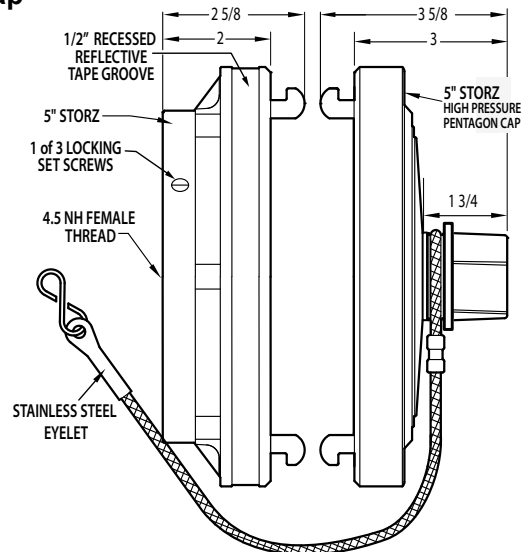

Other MICRALOX Hardcoat Colors Available



FEATURES:

- Aluminum Alloy 6061-T6 extruded forging only.
- (3) Stainless steel set screws for mounting.
- The converter is hard anodized aluminum metal face seal and hard anodized aluminum Storz ramp and lugs.
- The NH thread female adapter contains a flat rubber gasket which seals against the male hydrant nozzle.
- The head has a 1/2" relief machine cut around the outside creating a recess for the insertion of highly visible yellow reflective tape.

STORZ CAP AND CABLE CONSTRUCTION:

- **ASSEMBLY:** Both the center cap and the outer ring containing the Storz ramps and lugs is Aluminum alloy 6061-T6 forged extrusion. The outer ring has a 1/2" wide relief machine cut around the outside creating a recess for the insertion of the reflective tape. The cap has a high torque Hydrant Nut and can be removed with a Standard Hydrant Wrench.
- **CABLE:** 3/32", (7 x 7) Stainless steel aircraft cable w/ stainless steel eyelet end is supplied with the cap.
- **GASKETS:** Commercial grade neoprene and molded SBR rubber
- **SCREWS:** 304 stainless steel socket head screws.
- **FINISH:** All parts are aluminum. Storz Assembly is Micalox® Hardcoat Anodized blue, yellow, green, orange or red meeting Mil-A-8625-F, Type III, Class II spec. Other colors are available.
- **ALL COMPONENTS:** Meet or Exceed NFPA Specifications
- **REFLECTIVE TAPE:** Commercial grade reflective urethane film, LS-300c Refl 1, class 1, FP85 type 2, AFTM d4956-94 type 1, 7 year durability, 5.5 mil thickness.

Specifications

Storz Hydrant Converter: SZMC Low Profile, Hydrant Nut Cap Quantum® Hardcoat Anodized

5" Storz Metal Face X 4 1/2" NH Female, (3) Set Screws, Hi-visibility Reflective Tape, With Low Profile Hydrant Nut Storz Cap

PART #: SZMC5045-3

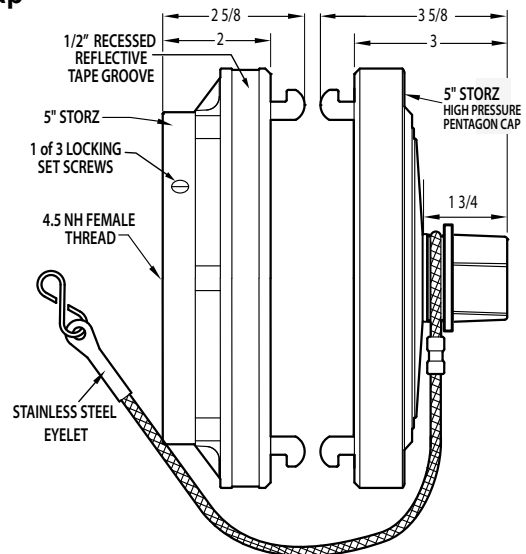

Other QUANTUM Hardcoat Colors Available



FEATURES:

- Aluminum Alloy 6061-T6 extruded forging only.
- (3) Stainless steel set screws for mounting.
- The converter is hard anodized aluminum metal face seal and hard anodized aluminum Storz ramp and lugs.
- The NH thread female adapter contains a flat rubber gasket which seals against the male hydrant nozzle.
- The head has a 1/2" relief machine cut around the outside creating a recess for the insertion of highly visible yellow reflective tape.

STORZ CAP AND CABLE CONSTRUCTION:

- **ASSEMBLY:** Both the center cap and the outer ring containing the Storz ramps and lugs is Aluminum alloy 6061-T6 forged extrusion. The outer ring has a 1/2" wide relief machine cut around the outside creating a recess for the insertion of the reflective tape. The cap has a high torque Hydrant Nut and can be removed with a Standard Hydrant Wrench.
- **CABLE:** 3/32", (7 x 7) Stainless steel aircraft cable w/ stainless steel eyelet end is supplied with the cap.
- **GASKETS:** Commercial grade neoprene and molded SBR rubber
- **SCREWS:** 304 stainless steel socket head screws.
- **FINISH:** All parts are aluminum. Storz Assembly is Quantum® Hardcoat Anodized blue, yellow, green, orange or red meeting Mil-A-8625-F, Type III, Class II spec. Other colors are available.
- **ALL COMPONENTS:** Meet or Exceed NFPA Specifications
- **REFLECTIVE TAPE:** Commercial grade reflective urethane film, LS-300c Refl 1, class 1, FP85 type 2, AFTM d4956-94 type 1, 7 year durability, 5.5 mil thickness.

Specifications

Storz Hydrant Converter: SZMC Low Profile, Hydrant Nut Cap Powder Coat

5" STORZ METAL FACE X 4 1/2" NH FEMALE, (3) SET SCREWS, HI-VISIBILITY REFLECTIVE TAPE,
WITH LOW PROFILE HYDRANT NUT STORZ CAP

PART #: SZMC5045-3-Y

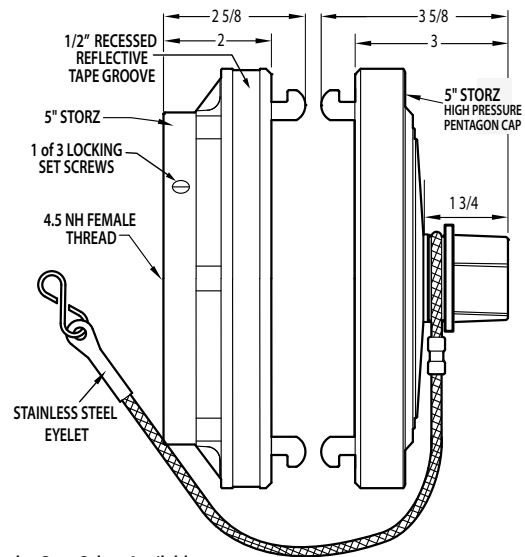

Other Powder Coat Colors Available



FEATURES:

- Aluminum Alloy 6061-T6 extruded forging only.
- (3) Stainless steel set screws for mounting.
- The converter is a powder coated aluminum metal face seal and powder coated aluminum Storz ramp and lugs.
- The NH thread female adapter contains a flat rubber gasket which seals against the male hydrant nozzle.
- The head has a 1/2" relief machine cut around the outside creating a recess for the insertion of highly visible yellow reflective tape.

STORZ CAP AND CABLE CONSTRUCTION:

- **ASSEMBLY:** Both the center cap and the outer ring containing the Storz ramps and lugs is Aluminum alloy 6061-T6 forged extrusion. The outer ring has a 1/2" wide relief machine cut around the outside creating a recess for the insertion of the reflective tape. The cap has a high torque Hydrant Nut and can be removed with a Standard Hydrant Wrench.
- **CABLE:** 3/32", (7 x 7) Stainless steel aircraft cable w/ stainless steel eyelet end is supplied with the cap.
- **GASKETS:** Commercial grade neoprene and molded SBR rubber
- **SCREWS:** 304 stainless steel socket head screws.
- **FINISH:** All parts are aluminum. Storz Assembly is fire engine red, evergreen, safety yellow, safety orange and dark blue Powder Coat.
- **REFLECTIVE TAPE:** Commercial grade reflective urethane film, LS-300c Refl 1, class 1, FP85 type 2, AFTM d4956-94 type 1, 7 year durability, 5.5 mil thickness.
- **ALL COMPONENTS:** Meet or Exceed NFPA 1963

Specifications

Storz Hydrant Converter: *SZMC Storz Standard Style*

Hardcoat Anodized - Natural Grey

5" Storz X NH Thread Hydrant Converter With Locking Set Screws

PART #: SZMC5045-7

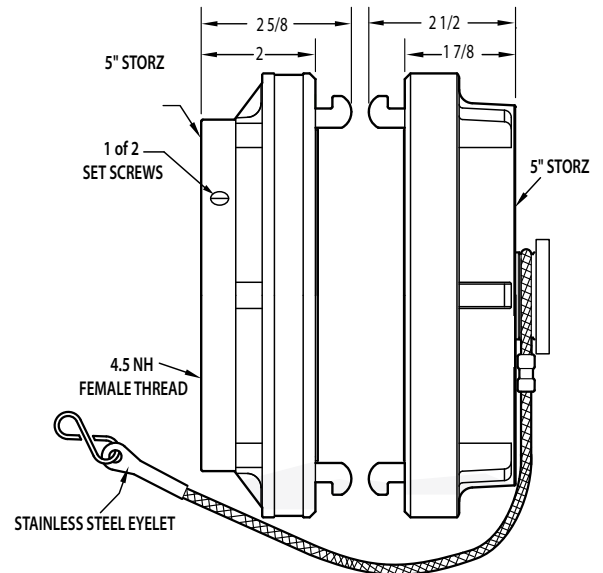
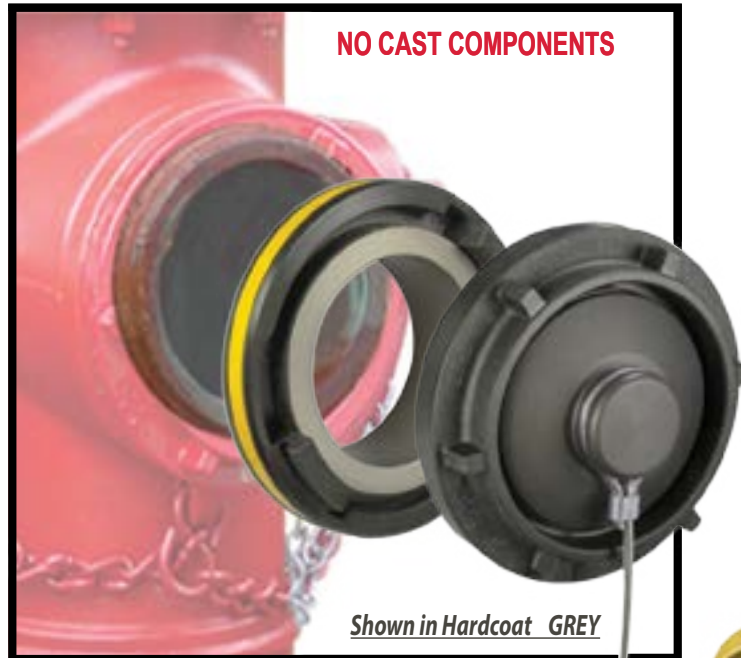

Other MICRALOX Hardcoat Colors Available

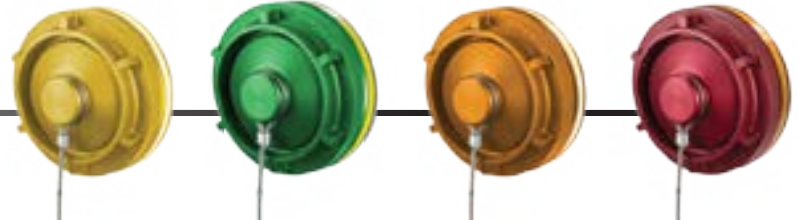

FEATURES:

- Aluminum Alloy 6061-T6 extruded forging only.
- (2) Stainless steel set screws for mounting.
- Set screws must be mounted 180 degrees apart.
- The converter is hard anodized aluminum metal face seal and hard anodized aluminum Storz ramp and lugs.
- The NH thread female adapter contains a flat rubber gasket which seals against the male hydrant nozzle.
- The high torque, anti theft cap requires a Storz wrench for removal.

STORZ CAP CONSTRUCTION:

- **ASSEMBLY:** Both the center cap and the outer assembly containing the Storz ramps and lugs is Aluminum alloy 6061-T6 forged extrusion only. Cap is equipped with cable. Once installed, the Storz Hydrant Converter with cap extends less than 3" from the hydrant nozzle.
- **CABLE:** 3/32", (7 x 7) Stainless steel aircraft cable w/ stainless steel eyelet end is supplied with the cap.
- **GASKETS:** Commercial grade neoprene and molded SBR rubber
- **SCREWS:** 304 stainless steel socket head screws.
- **FINISH:** All parts are aluminum. Storz Assembly is Hardcoat Anodized meeting Mil-A-8625-F, dark grey, Type III, Class I spec. Color is available with our Quantum® Hardcoat Anodizing which meets Mil spec 8625 Type III Class II.
- **ALL COMPONENTS:** Meet or Exceed NFPA Specifications.
- **REFLECTIVE TAPE:** Commercial grade yellow, reflective urethane film, LS-300c Refl 1, class 1, FP85 type 2, AFTM d4956-94 type 1, 7 year durability, 5.5 mil thickness.

Specifications

Storz Hydrant Converter: SZMC Storz Standard Style

Micalox® Hardcoat

5" Storz X NH Thread Hydrant Converter With Locking Set Screws

PART #: SZMC5045-7



Available with
Laser Engraving

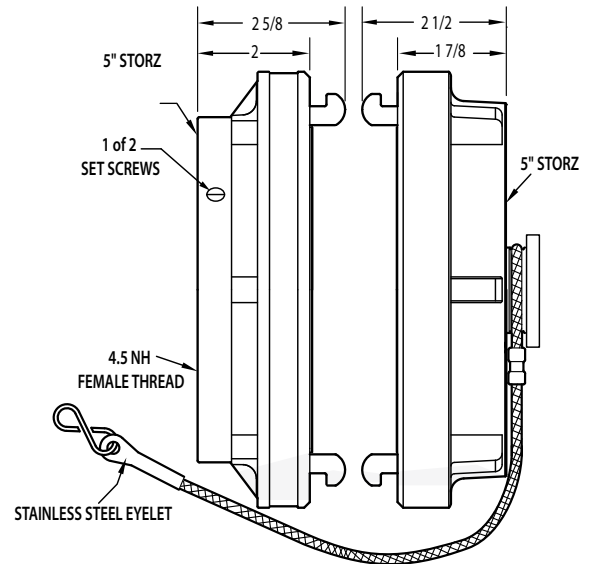

Other MICRALOX Hardcoat Colors Available

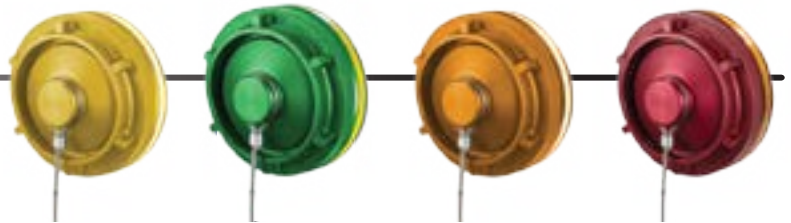

FEATURES:

- Aluminum Alloy 6061-T6 extruded forging only.
- (2) Stainless steel set screws for mounting.
- Set screws must be mounted 180 degrees apart.
- The converter is hard anodized aluminum metal face seal and hard anodized aluminum Storz ramp and lugs.
- The NH thread female adapter contains a flat rubber gasket which seals against the male hydrant nozzle.
- The high torque, anti theft cap requires a Storz wrench for removal.

STORZ CAP CONSTRUCTION:

- **ASSEMBLY:** Both the center cap and the outer assembly containing the Storz ramps and lugs is Aluminum alloy 6061-T6 forged extrusion only. Cap is equipped with cable. Once installed, the Storz Hydrant Converter with cap extends less than 3" from the hydrant nozzle.
- **CABLE:** 3/32", (7 x 7) Stainless steel aircraft cable w/ stainless steel eyelet end is supplied with the cap.
- **GASKETS:** Commercial grade neoprene and molded SBR rubber
- **SCREWS:** 304 stainless steel socket head screws.
- **FINISH:** All parts are aluminum. Storz Assembly is Micalox® Hardcoat Anodized in blue, yellow, green, orange, or red meeting Mil-A-8625-F, Type III, Class II spec. Other colors are available.
- **ALL COMPONENTS:** Per NFPA1142 ed. 2007
- **REFLECTIVE TAPE:** Commercial grade yellow, reflective urethane film, LS-300c Refl 1, class 1, FP85 type 2, AFTM d4956-94 type 1, 7 year durability, 5.5 mil thickness.

Specifications

Storz Hydrant Converter: SZMC Storz Standard Style

Quantum® Hardcoat

5" Storz X NH Thread Hydrant Converter With Locking Set Screws

PART #: SZMC5045-7

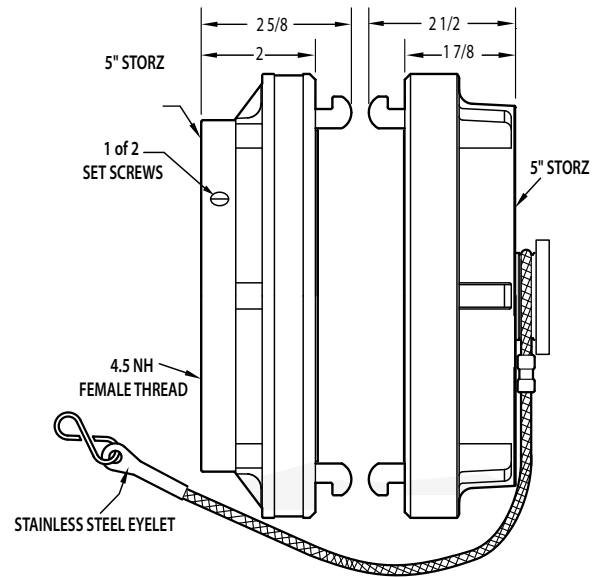

Other QUANTUM Hardcoat Colors Available

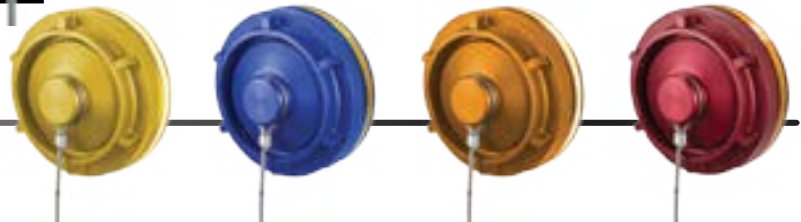

FEATURES:

- Aluminum Alloy 6061-T6 extruded forging only.
- (2) Stainless steel set screws for mounting.
- Set screws must be mounted 180 degrees apart.
- The converter is hard anodized aluminum metal face seal and hard anodized aluminum Storz ramp and lugs.
- The NH thread female adapter contains a flat rubber gasket which seals against the male hydrant nozzle.
- The high torque, anti theft cap requires a Storz wrench for removal.

STORZ CAP CONSTRUCTION:

- **ASSEMBLY:** Both the center cap and the outer assembly containing the Storz ramps and lugs is Aluminum alloy 6061-T6 forged extrusion only. Cap is equipped with cable. Once installed, the Storz Hydrant Converter with cap extends less than 3" from the hydrant nozzle.
- **CABLE:** 3/32", (7 x 7) Stainless steel aircraft cable w/ stainless steel eyelet end is supplied with the cap.
- **GASKETS:** Commercial grade neoprene and molded SBR rubber
- **SCREWS:** 304 stainless steel socket head screws.
- **FINISH:** All parts are aluminum. Storz Assembly is Quantum® Hardcoat Anodized in blue, yellow, green, orange, or red meeting Mil-A-8625-F, Type III, Class II spec. Other colors are available.
- **ALL COMPONENTS:** Per NFPA1142 ed. 2007
- **REFLECTIVE TAPE:** Commercial grade yellow, reflective urethane film, LS-300c Refl 1, class 1, FP85 type 2, AFTM d4956-94 type 1, 7 year durability, 5.5 mil thickness.

Storz Hydrant Converter

“Saves Time, Saves Lives”

Large Diameter Hose with Storz connections have quickly become a fire industry standard. The conversion of existing threaded fire hydrants to quick quarter turn Storz connections is becoming one of the first steps that communities are taking in a quest toward, quicker response time and interoperability.

Kocheck, the United States leader in Storz connections is proud to offer you our line of Storz Hydrant Converters.

ONE INSTALLATION PROVIDES THOUSANDS OF QUICK, LIFE SAVING CONNECTIONS!

Installation Steps:

1. Remove the existing Hydrant Cap
2. Thread our quality forged Storz Connector, & tighten the set screws
3. Install the Cap and Cable



Connection Steps:

1. Remove the Storz Cap with a simple quarter turn
 2. Attach the hose with a quick quarter turn
- OPTIONAL:** Hydrant Nut Cap (Shown)



Now *one* wrench can open and close the Hydrant as well as **REMOVE** the cap!

Specifications

Storz Hydrant Converter: SZMC Storz Standard Style

5" STORZ X NH THREAD HYDRANT CONVERTER WITH LOCKING SET SCREWS

Hardcoat

PART #: SZMC5045-2

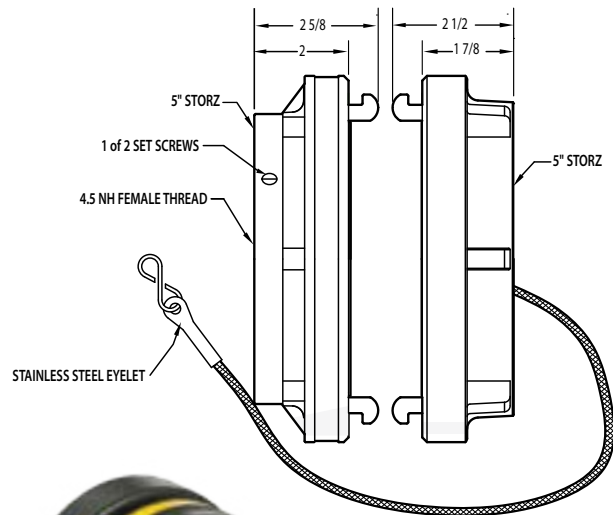

4 Inch Style

FEATURES:

- Aluminum Alloy 6061-T6 extruded forging only.
- (2) Stainless steel set screws for mounting.
- Set screws must be mounted 180 degrees apart.
- The converter is hard anodized aluminum metal face seal and hard anodized aluminum Storz ramp and lugs.
- The NH thread female adapter contains a flat rubber gasket which seals against the male hydrant nozzle.
- The high torque, anti theft cap requires a Storz wrench for removal.

STORZ CAP AND CABLE CONSTRUCTION:

- **ASSEMBLY:** Both the center cap and the outer assembly containing the Storz ramps and lugs is Aluminum alloy 6061-T6 forged extrusion only.
- **CABLE:** 3/32", (7 x 7) Stainless steel aircraft cable w/ stainless steel eyelet end is supplied with the cap. Once installed, the Storz Hydrant Converter with cap extends less than 3" from the hydrant nozzle.
- **GASKETS:** Commercial grade neoprene and molded SBR rubber
- **SCREWS:** 304 stainless steel socket head screws.
- **FINISH:** All aluminum parts Hardcoat Anodized to Mil-A-8625-F, dark grey, Type III, Class I spec.
- **ALL COMPONENTS:** Meet or Exceed NFPA Specifications.
- **REFLECTIVE TAPE:** Commercial grade reflective urethane film, LS-300c Refl 1, class 1, FP85 type 2, AFTM d4956-94 type 1, 7 year durability, 5.5 mil thickness.

Specifications

Storz Hydrant Converter: SZMC Storz Standard Style Micralox® Hardcoat

5" Storz X NH Thread Hydrant Converter With Locking Set Screws

PART #: SZMC5045-2

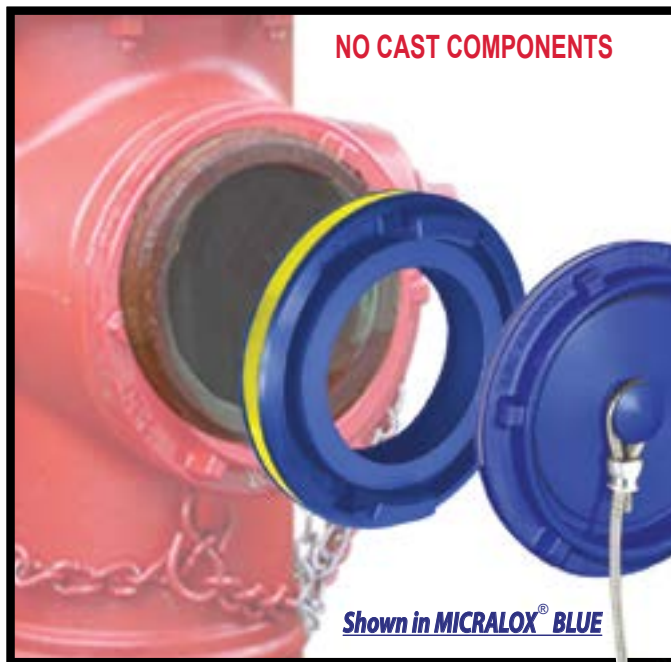

Available with
Laser Engraving

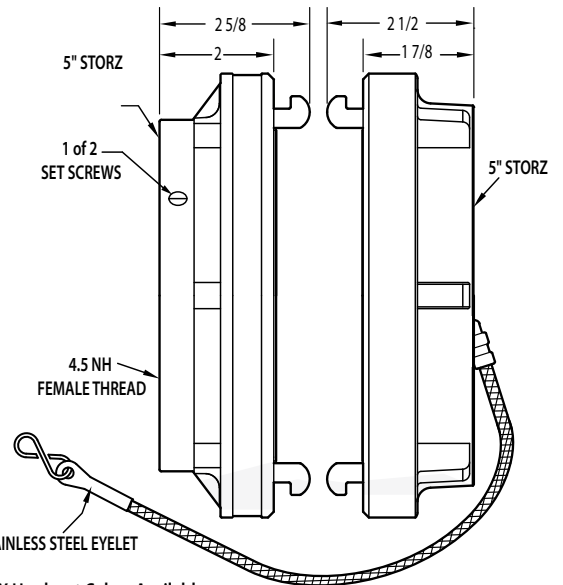

Other MICRALOX Hardcoat Colors Available



FEATURES:

- Aluminum Alloy 6061-T6 extruded forging only.
- (2) Stainless steel set screws for mounting.
- Set screws must be mounted 180 degrees apart.
- The converter is hard anodized aluminum metal face seal and hard anodized aluminum Storz ramp and lugs.
- The NH thread female adapter contains a flat rubber gasket which seals against the male hydrant nozzle.
- The high torque, anti theft cap requires a Storz wrench for removal.

STORZ CAP CONSTRUCTION:

- **ASSEMBLY:** Both the center cap and the outer assembly containing the Storz ramps and lugs is Aluminum alloy 6061-T6 forged extrusion only. Cap is equipped with cable. Once installed, the Storz Hydrant Converter with cap extends less than 3" from the hydrant nozzle.
- **CABLE:** 3/32", (7 x 7) Stainless steel aircraft cable w/ stainless steel eyelet end is supplied with the cap.
- **GASKETS:** Commercial grade neoprene and molded SBR rubber
- **SCREWS:** 304 stainless steel socket head screws.
- **FINISH:** All parts are aluminum. Storz Assembly is Micralox® Hardcoat Anodized in blue, yellow, green, orange, or red meeting Mil-A-8625-F, Type III, Class II spec. Other colors are available.
- **ALL COMPONENTS:** Per NFPA1142 ed. 2007
- **REFLECTIVE TAPE:** Commercial grade yellow, reflective urethane film, LS-300c Refl 1, class 1, FP85 type 2, AFTM d4956-94 type 1, 7 year durability, 5.5 mil thickness.

Specifications

Storz Hydrant Converter: SZMC Storz Standard Style

Quantum® Hardcoat

5" Storz X NH Thread Hydrant Converter With Locking Set Screws

PART #: SZMC5045-2



Available with
Laser Engraving

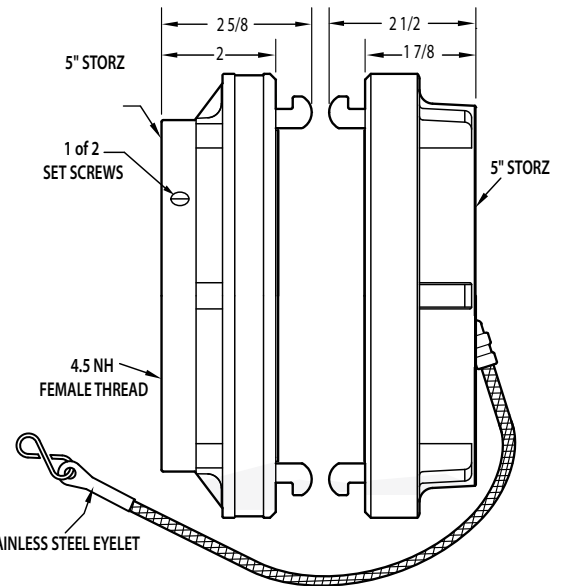

Other QUANTUM Hardcoat Colors Available



FEATURES:

- Aluminum Alloy 6061-T6 extruded forging only.
- (2) Stainless steel set screws for mounting.
- Set screws must be mounted 180 degrees apart.
- The converter is hard anodized aluminum metal face seal and hard anodized aluminum Storz ramp and lugs.
- The NH thread female adapter contains a flat rubber gasket which seals against the male hydrant nozzle.
- The high torque, anti theft cap requires a Storz wrench for removal.

STORZ CAP CONSTRUCTION:

- **ASSEMBLY:** Both the center cap and the outer assembly containing the Storz ramps and lugs is Aluminum alloy 6061-T6 forged extrusion only. Cap is equipped with cable. Once installed, the Storz Hydrant Converter with cap extends less than 3" from the hydrant nozzle.
- **CABLE:** 3/32", (7 x 7) Stainless steel aircraft cable w/ stainless steel eyelet end is supplied with the cap.
- **GASKETS:** Commercial grade neoprene and molded SBR rubber
- **SCREWS:** 304 stainless steel socket head screws.
- **FINISH:** All parts are aluminum. Storz Assembly is Quantum® Hardcoat Anodized in blue, yellow, green, orange, or red meeting Mil-A-8625-F, Type III, Class II spec. Other colors are available.
- **ALL COMPONENTS:** Per NFPA1142 ed. 2007
- **REFLECTIVE TAPE:** Commercial grade yellow, reflective urethane film, LS-300c Refl 1, class 1, FP85 type 2, AFTM d4956-94 type 1, 7 year durability, 5.5 mil thickness.

Specifications

Storz Hydrant Converter: SZMC Storz Standard Style Hardcoat Combination

5" STORZ X NH THREAD HYDRANT CONVERTER WITH LOCKING SET SCREWS

PART #: SZMC5045-2

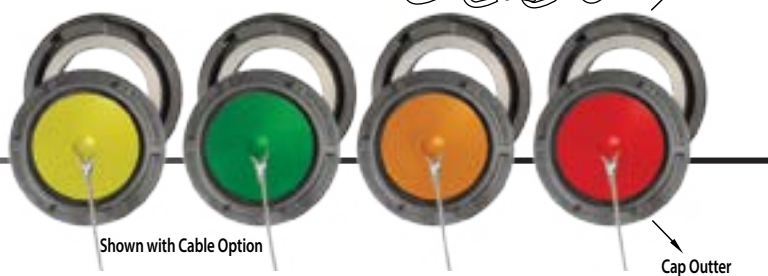
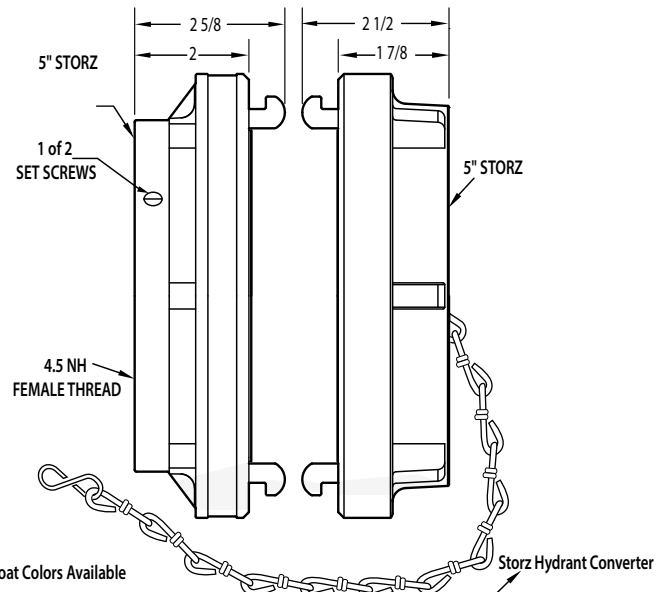
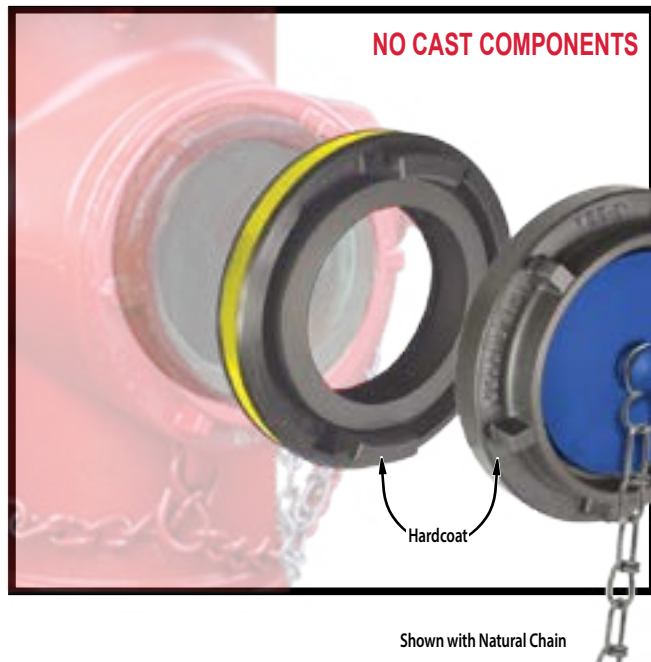

FEATURES:

- Aluminum Alloy 6061-T6 extruded forging only.
- (2) Stainless steel set screws for mounting.
- Set screws must be mounted 180 degrees apart.
- The converter is hard anodized aluminum metal face seal and hard anodized aluminum Storz ramp and lugs.
- The NH thread female adapter contains a flat rubber gasket which seals against the male hydrant nozzle.
- The high torque, anti theft cap requires a Storz wrench for removal.

STORZ CAP CONSTRUCTION:

- **ASSEMBLY:** Both the center cap and the outer assembly containing the Storz ramps and lugs is Aluminum alloy 6061-T6 forged extrusion only. Cap is equipped with a chain. Once installed, the Storz Hydrant Converter with cap extends less than 3" from the hydrant nozzle.
- **GASKETS:** Commercial grade neoprene and molded SBR rubber
- **SCREWS:** 304 stainless steel socket head screws.
- **FINISH:** All are aluminum parts. Storz Hydrant Converter and Cap Outer are Hardcoat Anodized to Mil-A-8625-F, Type III, Class I—dark grey. Cap Inner is Micalox® Hardcoat in blue, yellow, green, orange or red meeting Mil-A-8625-F, Type III, Class II spec. Other colors are available.
- **ALL COMPONENTS:** Per NFPA1142 ed. 2007

OPTIONAL

- **REFLECTIVE TAPE:** Commercial grade yellow, reflective urethane film, LS-300c Refl 1, class 1, FP85 type 2, AFTM d4956-94 type 1, 7 year durability, 5.5 mil thickness.

Storz Hydrant Adapter SZMC Style

Hardcoat Anodized

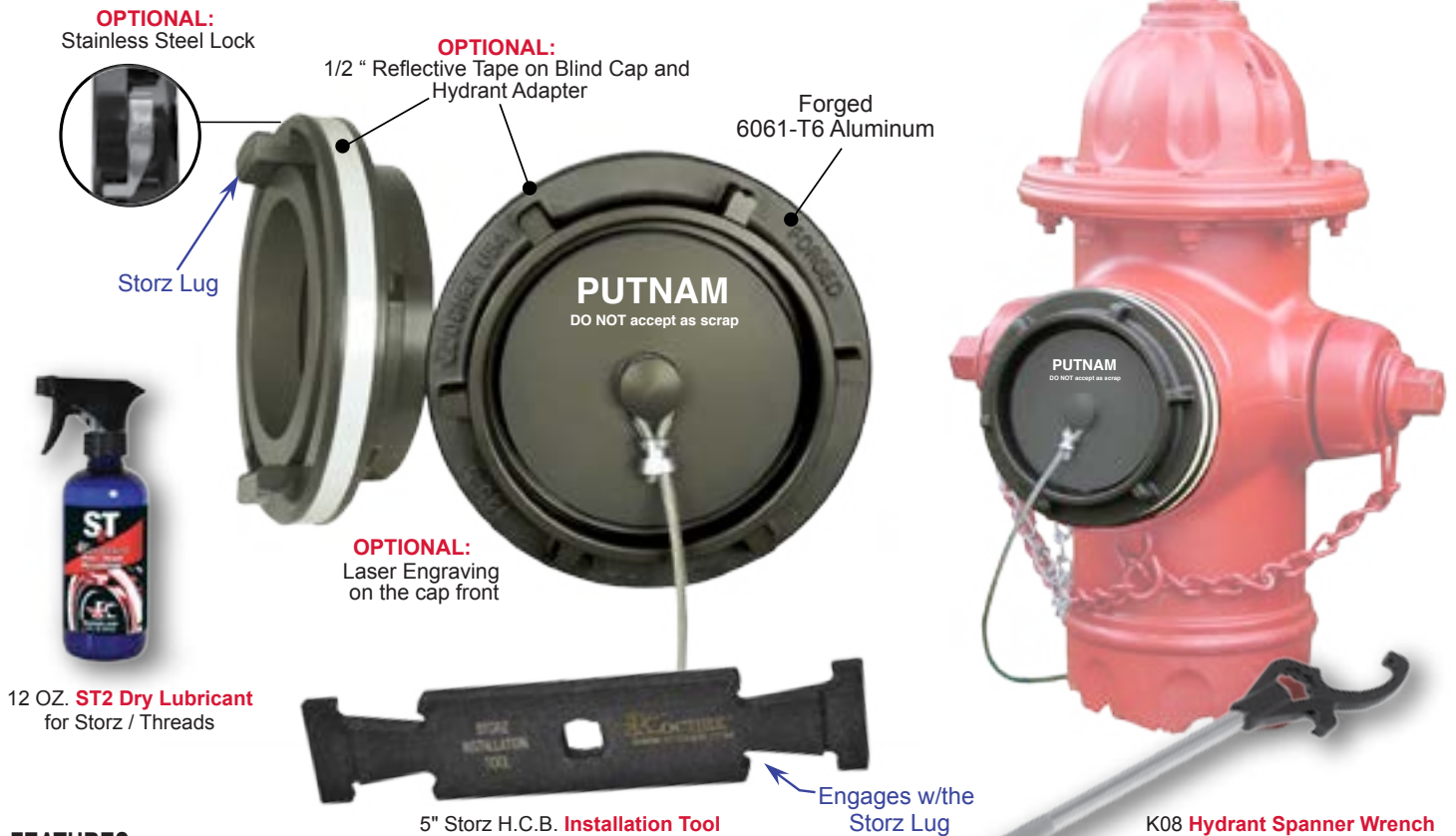

12 OZ. **ST2 Dry Lubricant**
for Storz / Threads

FEATURES:

- Aluminum Alloy 6061-T6 extruded forging only.
- (2) Stainless steel set screws for mounting.
- Set screws must be mounted 180 degrees apart.
- The converter is hard anodized aluminum metal face seal and hard anodized aluminum Storz ramp and lugs.
- The NH thread female adapter contains a flat rubber gasket which seals against the male hydrant nozzle.
- The high torque, anti theft cap requires a Storz wrench for removal.

STORZ CAP AND CABLE CONSTRUCTION:

- **ASSEMBLY:** Both the center cap and the outer assembly containing the Storz ramps and lugs is Aluminum alloy 6061-T6 forged extrusion only.
- **CABLE:** 3/32", (7 x 7) Stainless steel aircraft cable w/ stainless steel eyelet end is supplied with the cap. Once installed, the Storz Hydrant Converter with cap extends less than 3" from the hydrant nozzle.
- **GASKETS:** Commercial grade neoprene and molded SBR rubber
- **SCREWS:** 304 stainless steel socket head screws.
- **FINISH:** All parts are aluminum. Hardcoat Anodized to Mil-A-8625-F, dark grey, Type III, Class I spec.
- **ALL COMPONENTS:** Meet or Exceed NFPA Specifications.
- **REFLECTIVE TAPE:** Commercial grade reflective urethane film, LS-300c Refl 1, class 1, FP85 type 2, AFTM d4956-94 type 1, 7 year durability, 5.5 mil thickness.

4" and 5" Storz Security Lock

PART #'S **SSMSL4 / SSMSL5**

PATENT PENDING

The **STORZ SECURITY LOCK** is a stainless steel device that can be installed on "any 4" or 5" storz fitting" to safely secure and lock Caps, Valves, or Hoses. When installed on Fire Sprinkler Storz Connections we recommend using a "Break Away" lock.

APPLICATIONS

- Protect Fire Hydrant Waterways
- Deter Theft of Caps
- Prevent Entry of Obstructions to Fire Sprinkler Systems Connections
- Secure Temporary or Emergency Hose Lines and Valves
- Use to Tag/Lock Out "out of service hydrants"

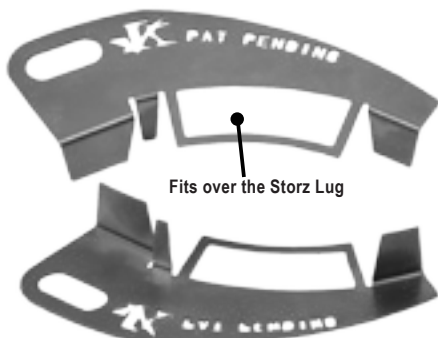

• 1 Set Per Package

- Stainless Steel
- Patent Pending

• Installation Instructions



BUILDING CONNECTIONS

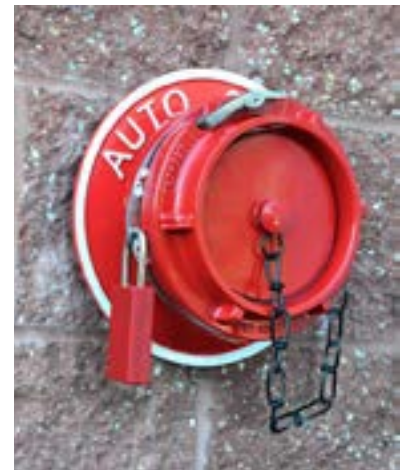

HYDRANTS



DRY HYDRANT CONNECTIONS



OTHER STORZ CONNECTIONS

