

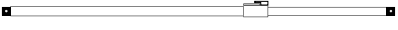

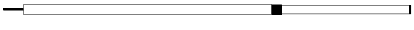

INCLUDED IN KIT:

- 4x  Ground Pegs
- 3x  Spreader Bar
- 4x  9ft Pole
- 1x  C-Clip Rafter
- 6x  Sprung Guy Ropes
- 1x  Canopy

STEP 1

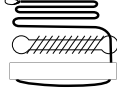
Fully extend your awning so the sail track groove in the awning barrel is in the 3 o'clock position and attach the anti-flap kit.

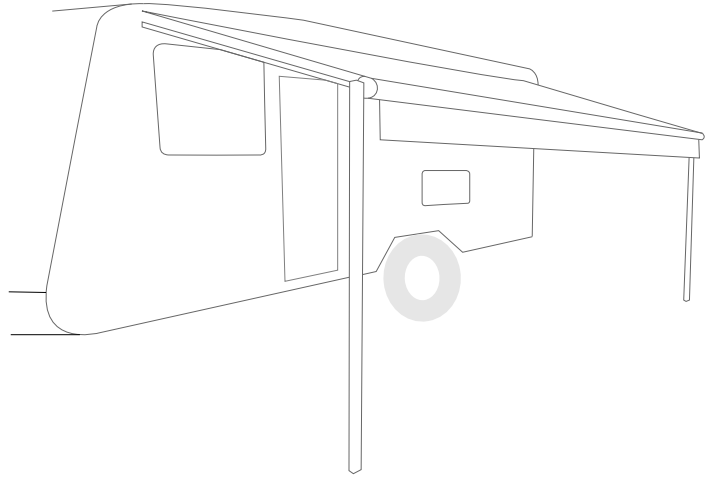

STEP 2

Slide the canopy into the sail track on the anti-flap kit.

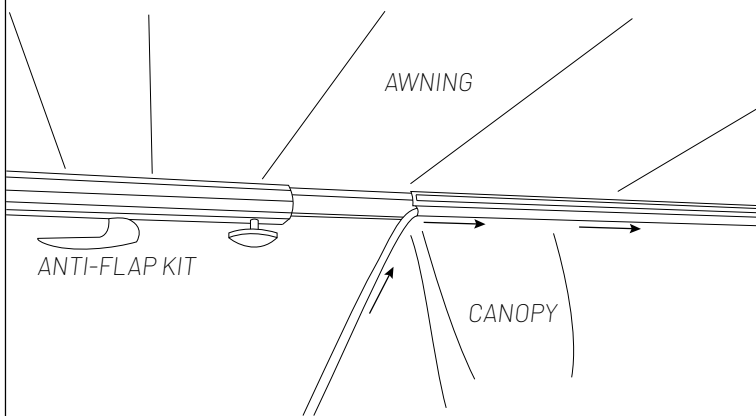

STEP 3

Feed the canopy into the sail track on the other side of the anti-flap kit.

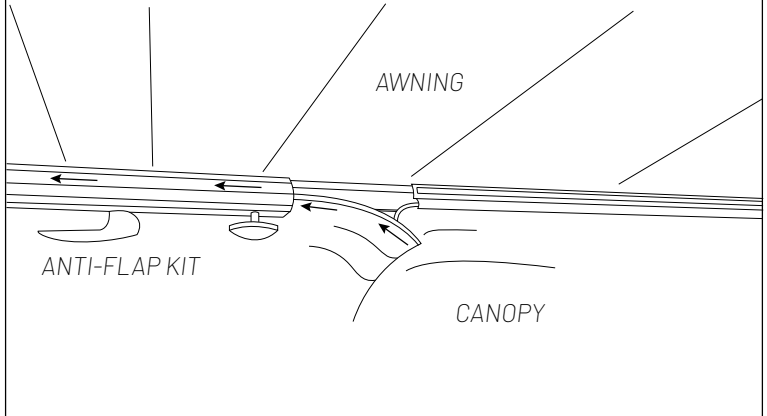

STEP 4

Measure out and extend the spreader bars to fit the awning canopy holes.

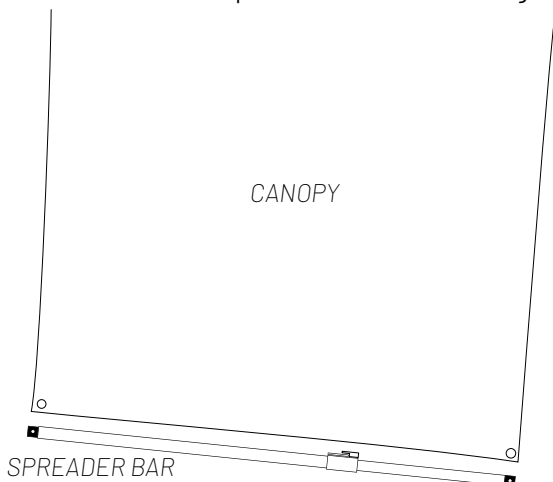

STEP 5

Feed the spreader bars (x3) into the pockets on the underside of the canopy.

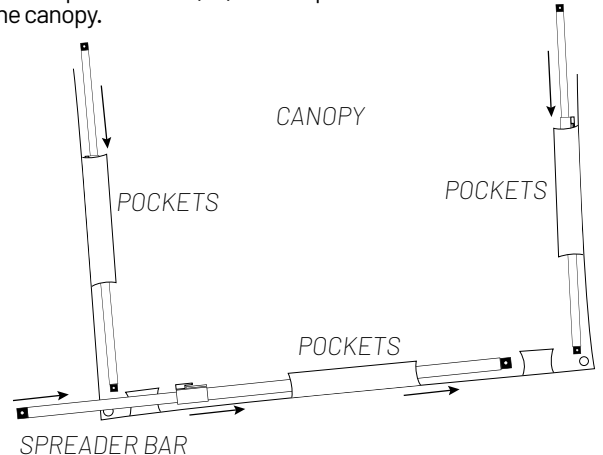

Porch

STEP 6

Adjust 4x 9ft poles to the same height as the rear of the anti-flap kit, and front of the anti-flap kit.

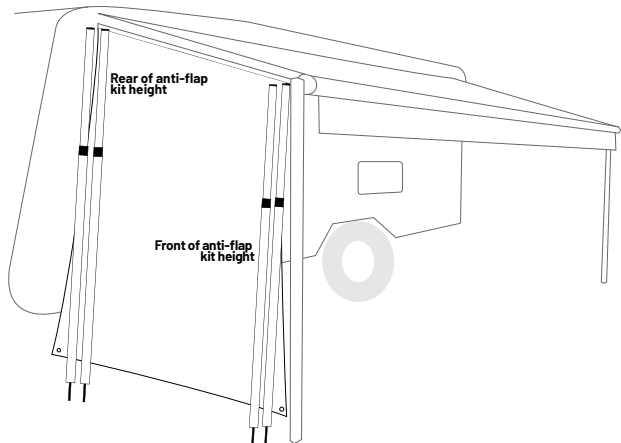

STEP 7

Insert the 9ft pole spigot through the eyelets on the two spreader bars and through the canopy corner eyelet. Repeat for all bars.

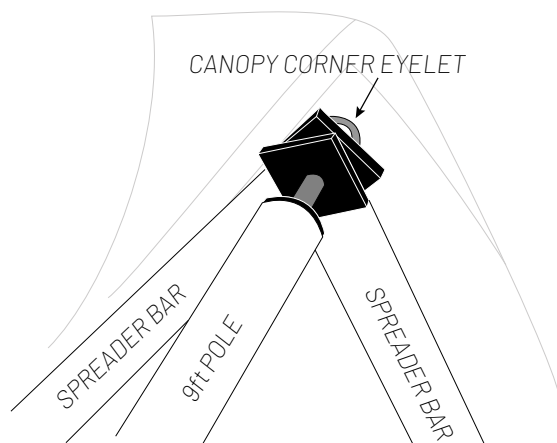

STEP 8

Raise the porch and adjust the poles and spreader bars until all are tight.

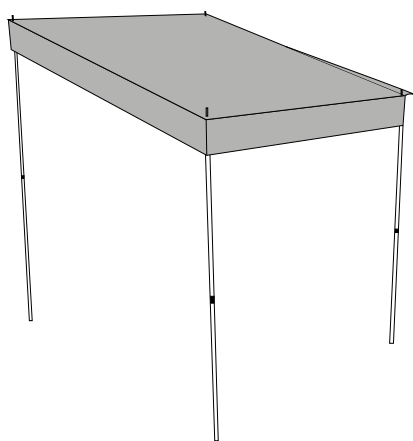

STEP 9

Secure the springs to the ground with pegs and attach rope loops over 9ft pole spigots on the top of your porch. Tighten by pulling the wooden handle.

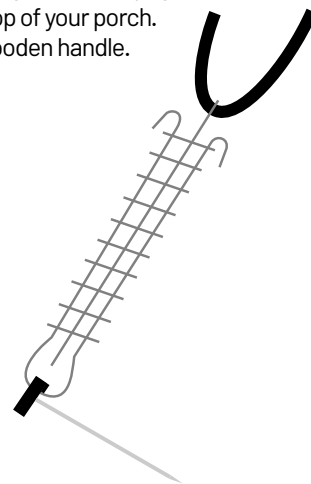

STEP 10

Attach C-Clip rafter between the front and rear spreader bars, and adjust the length using the handle on the C-Clip rafter.

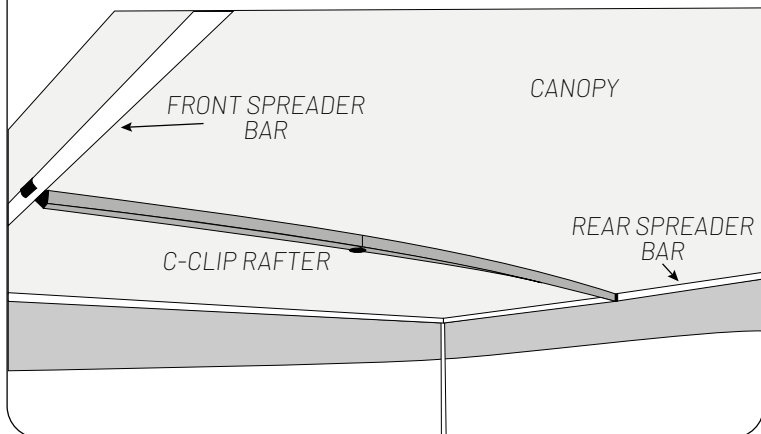

Your porch is now ready to use.

