

APPLITEC

# TOOLING-Line

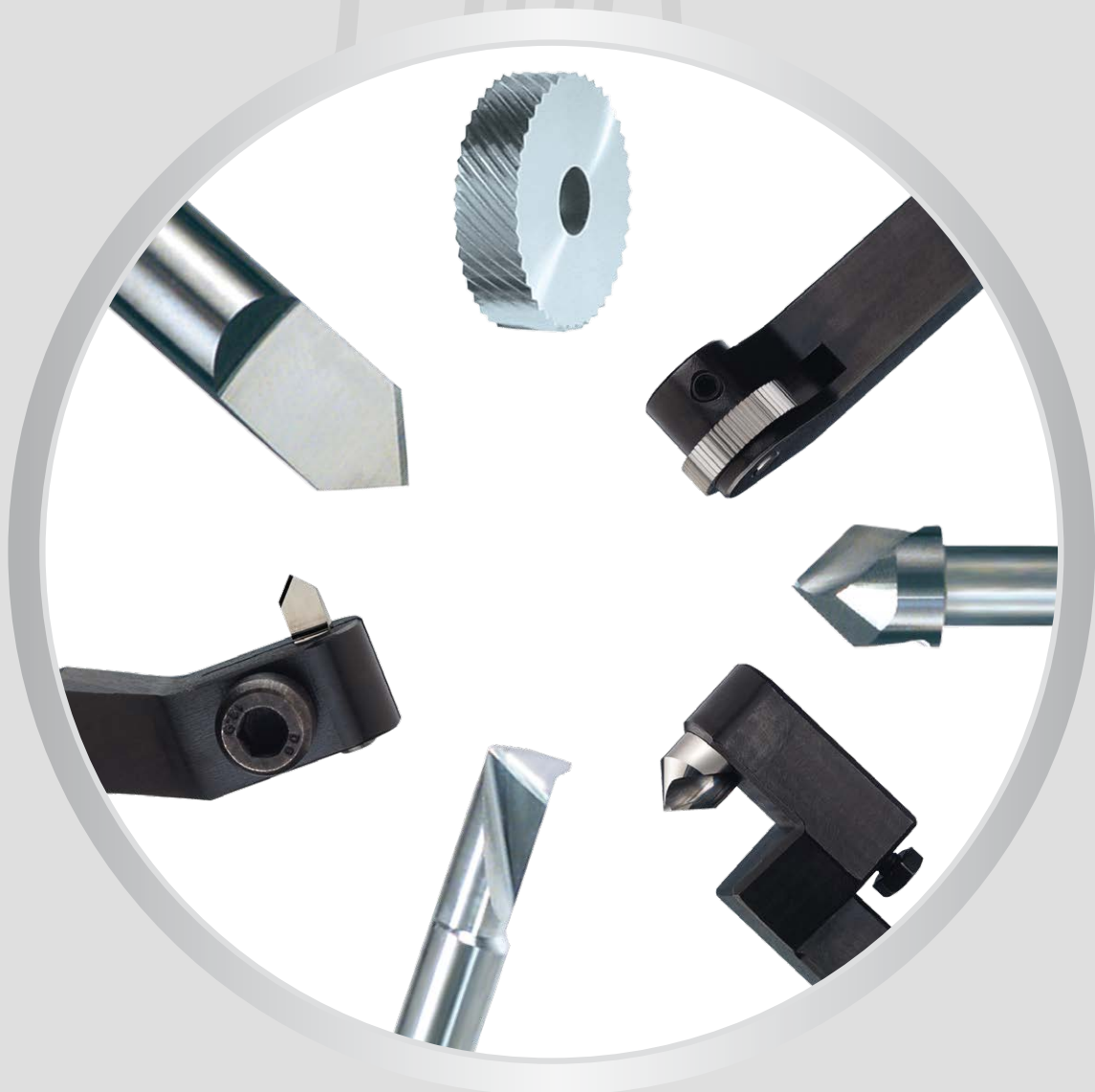

APPLITEC  
SWISS TOOLING

## Outils et porte-outils traditionnels pour le décolletage et la mécanique de précision

- Porte-outils
- Forets à centrer
- Burins intérieurs
- Porte-molettes
- Molettes MD

## Übliche Werkzeuge und Halter für Decolletage und Präzisionsmechanik

- Werkzeughalter
- Zentrierbohrer
- Innendrehwerkzeuge
- Rändelhalter
- Rändelrädchen

## Usual tools and tool holders for automatic lathes and precision mechanics

- Toolholder
- Centring drills
- Internal turning tools
- Knurl holders
- Knurling wheels



## Index

Porte-outils  
Werkzeughalter  
Tool holders

**Type 14xx / 24xx**



> 2

Porte-outils monoblocs pour machines Tornos  
Monoblockwerkzeughalter für Tornos Maschinen  
Monobloc tool holders for Tornos machines

**Type 2435 / 2436**

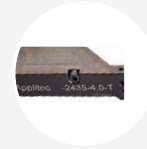

> 12

Forets à centrer plats  
Zentrierflachbohrer  
Centering flat drills

**Type 1200 / 2200**



> 14

Forets à centrer hélicoïdaux  
Zentrierspiralbohrer  
Centering twist drills

**Type 15xx / 25xx**



> 15

Burins intérieurs en métal dur  
Vollhartmetall Innendrehwerkzeuge  
Solid carbide internal turning tools

**Type 16xx / 26xx**



> 16

Porte-molettes  
Rändelhalter  
Knurl holders

**Type 1402 / 2402**



> 18

Molettes en métal dur  
Vollhartmetall Rändelrädchen  
Solid carbide knurling wheels

**Type 1107**



> 19

# TOOLING-Line

Porte-outils

Werkzeughalter

Tool holders

1400-J / 2400-J

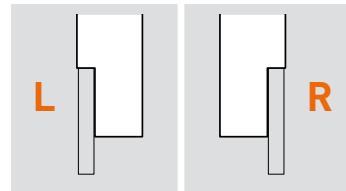
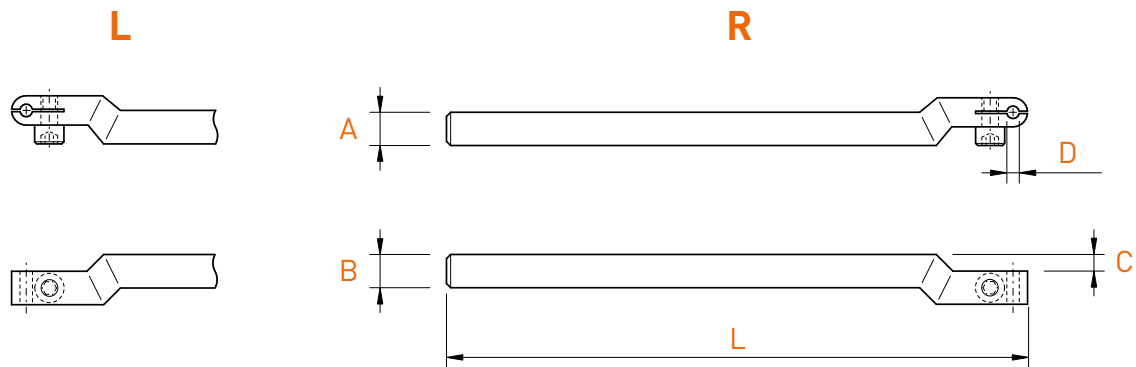

A x B	L	C	D	Art. N°	Art. N°
6 x 6	132	3	1.5	1400-J-615	2400-J-615
6 x 6	132	3	2.0	1400-J-620	2400-J-620
6 x 6	132	3	3.0	1400-J-630	2400-J-630
7 x 7	140	3	1.5	1400-J-715	2400-J-715
7 x 7	140	3	2.0	1400-J-720	2400-J-720
7 x 7	140	3	3.0	1400-J-730	2400-J-730
8 x 8	140	4	1.5	1400-J-815	2400-J-815
8 x 8	140	4	2.0	1400-J-820	2400-J-820
8 x 8	140	4	3.0	1400-J-830	2400-J-830

Porte-outils  
Werkzeughalter  
Tool holders

1401-K / 2401-K

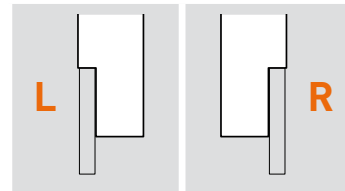
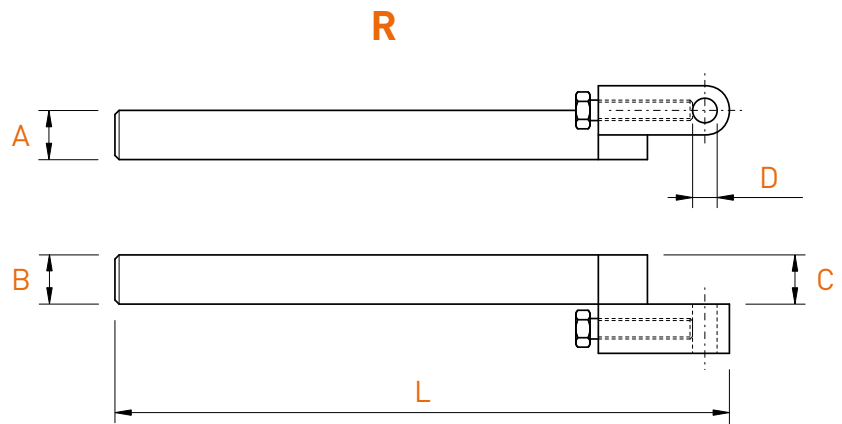
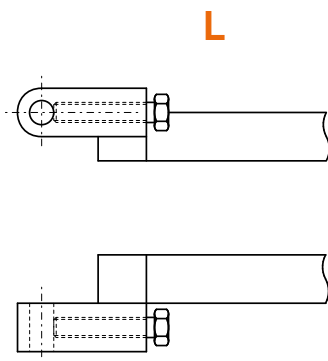

A x B	L	C	D	Art. N°	Art. N°
7 x 7	146	7	2.0	1401-K-720	-
7 x 7	146	7	3.0	1401-K-730	2401-K-730
7 x 7	146	7	4.0	1401-K-740	2401-K-740
8 x 8	146	8	2.0	1401-K-820	-
8 x 8	146	8	3.0	1401-K-830	2401-K-830
8 x 8	146	8	4.0	1401-K-840	2401-K-840
8 x 8	146	8	5.0	1401-K-850	2401-K-850
8 x 8	146	8	6.0	1401-K-860	2401-K-860
10 x 10	150	10	3.0	-	2401-K-1030
10 x 10	150	10	4.0	1401-K-1040	2401-K-1040
10 x 10	150	10	5.0	1401-K-1050	2401-K-1050
10 x 10	150	10	6.0	1401-K-1060	2401-K-1060
10 x 10	150	10	7.0	1401-K-1070	2401-K-1070
12 x 12	150	12	3.0	-	2401-K-1230
12 x 12	150	12	4.0	1401-K-1240	2401-K-1240
12 x 12	150	12	5.0	1401-K-1250	2401-K-1250
12 x 12	150	12	6.0	1401-K-1260	2401-K-1260
12 x 12	150	12	8.0	1401-K-1280	2401-K-1280
14 x 14	150	14	4.0	1401-K-1440	2401-K-1440
14 x 14	150	14	6.0	1401-K-1460	2401-K-1460
14 x 14	150	14	8.0	1401-K-1480	2401-K-1480

# TOOLING-Line

Porte-outils

Werkzeughalter

Tool holders

1420 / 2420

L

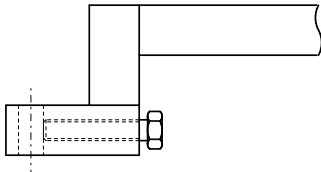
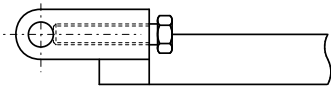

R

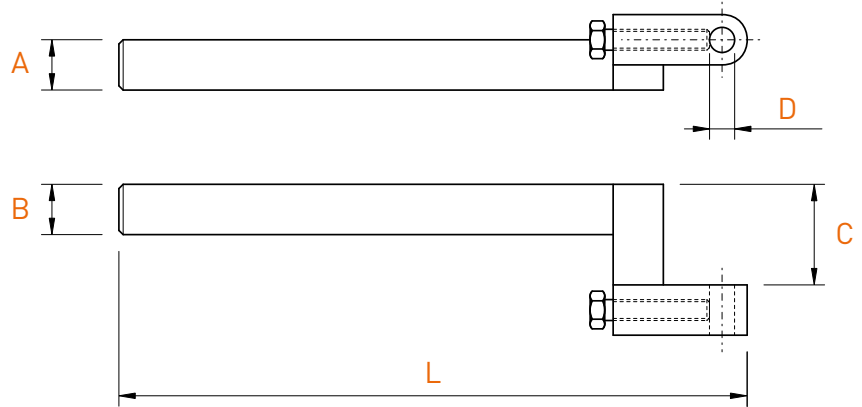

L

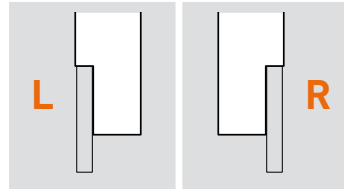

R

A x B	L	C	D	Art. N°	Art. N°
7 x 7	146	12	4.0	1420-7124	2420-7124
8 x 8	146	12	4.0	1420-8124	2420-8124
8 x 8	146	14	3.0	1420-8143	2420-8143
8 x 8	146	15	5.0	1420-8155	2420-8155
8 x 8	146	20	5.0	1420-8205	2420-8205
10 x 10	150	20	6.0	1420-10206	2420-10206
12 x 12	150	18	6.0	1420-12186	2420-12186
12 x 12	150	18	8.0	1420-12188	-
12 x 12	150	24	8.0	1420-12248	2420-12248
14 x 14	150	20	8.0	1420-14208	2420-14208
14 x 14	150	24	8.0	1420-14248	2420-14248

Porte-outils

Werkzeughalter

Tool holders

∅ 12 x 12

1460

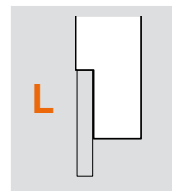
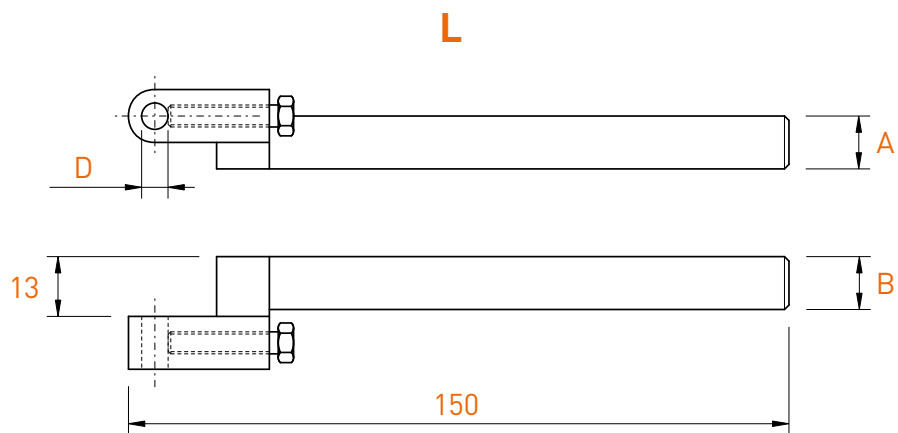

A x B	D	Art. N°
12 x 12	4.0	1460-4
12 x 12	5.0	1460-5
12 x 12	6.0	1460-6
12 x 12	8.0	1460-8

# TOOLING-Line

Porte-outils

Werkzeughalter

Tool holders

∅ 10 x 10

2450-SP

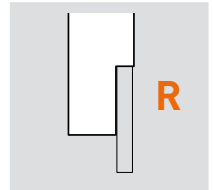
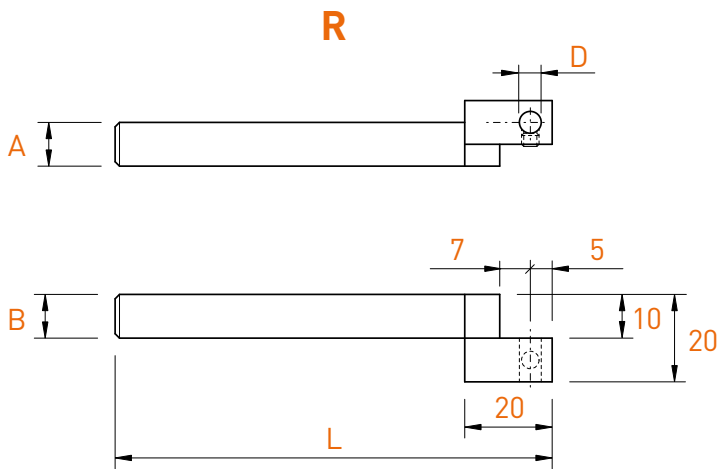

A x B	L	D	Art. N°
10 x 10	100	3.0	2450-SP-3
10 x 10	100	4.0	2450-SP-4
10 x 10	100	5.0	2450-SP-5
10 x 10	100	6.0	2450-SP-6
10 x 10	120	3.0	2450-SP-3-120
10 x 10	120	4.0	2450-SP-4-120
10 x 10	120	5.0	2450-SP-5-120
10 x 10	120	6.0	2450-SP-6-120

Porte-outils

Werkzeughalter

Tool holders

∅ 10 x 10

2470

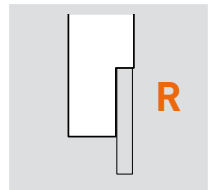
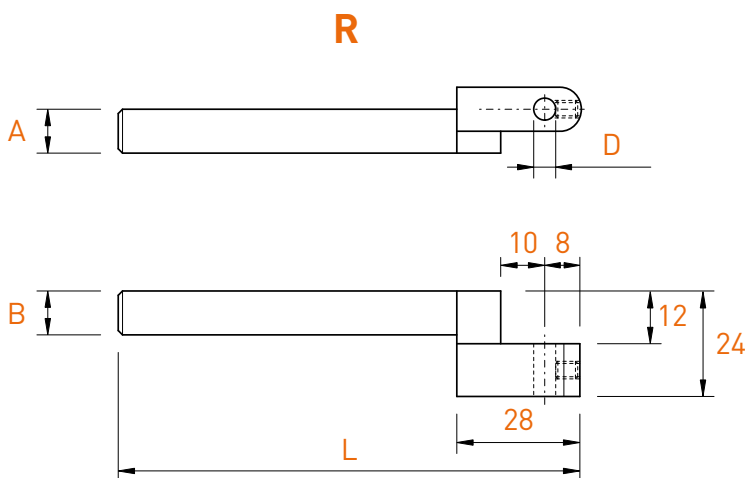

A x B	L	D	Art. N°
10 x 10	105	3.0	2470-3
10 x 10	105	4.0	2470-4
10 x 10	105	5.0	2470-5
10 x 10	105	6.0	2470-6
10 x 10	105	7.0	2470-7



Porte-outils  
Werkzeughalter  
Tool holders

∅ 12 x 12

2450

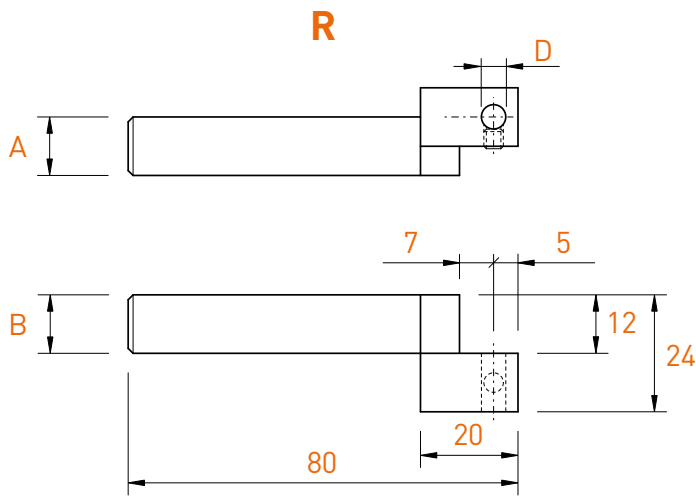

A x B	D	Art. N°
12 x 12	3.0	2450-3
12 x 12	4.0	2450-4
12 x 12	5.0	2450-5
12 x 12	6.0	2450-6
12 x 12	8.0	2450-8

Porte-outils  
Werkzeughalter  
Tool holders

∅ 12 x 12

2460

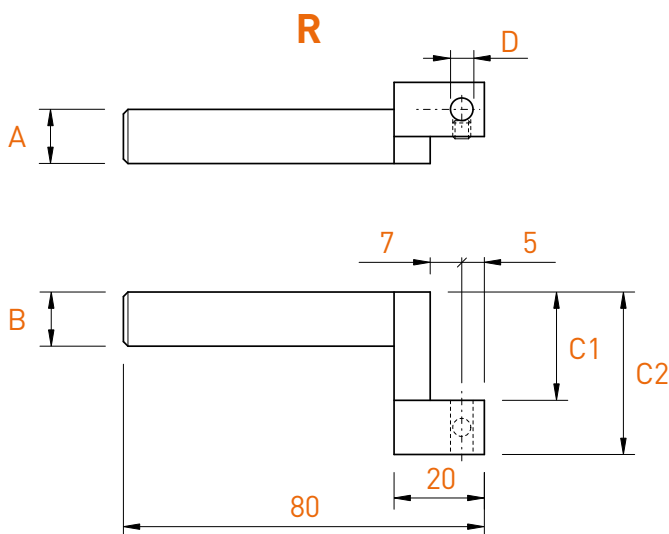

A x B	C1	C2	D	Art. N°
12 x 12	16	28	4.0	2460-284
12 x 12	16	28	6.0	2460-286
12 x 12	16	28	8.0	2460-288
12 x 12	20	32	4.0	2460-324
12 x 12	20	32	6.0	2460-326
12 x 12	20	32	8.0	2460-328
12 x 12	24	36	4.0	2460-364
12 x 12	24	36	6.0	2460-366
12 x 12	24	36	8.0	2460-368

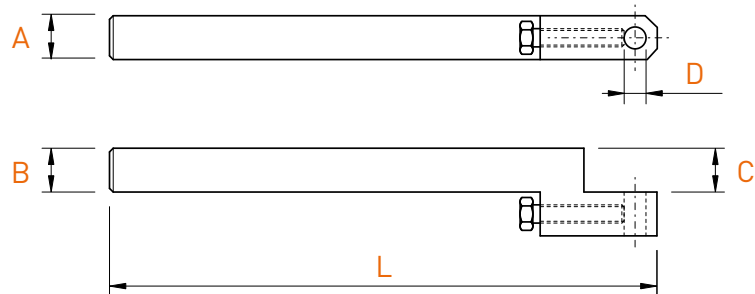

A x B	L	C	D	Art. N°
8 x 8	120	8	3.0	<b>2405-K-830</b>
8 x 8	120	8	4.0	<b>2405-K-840</b>
8 x 8	120	8	5.0	<b>2405-K-850</b>
8 x 8	120	8	6.0	<b>2405-K-860</b>
10 x 10	100	10	4.0	<b>2405-K-1040</b>
10 x 10	100	10	5.0	<b>2405-K-1050</b>
10 x 10	100	10	6.0	<b>2405-K-1060</b>
12 x 12	150	12	4.0	<b>2405-K-1240</b>
12 x 12	150	12	6.0	<b>2405-K-1260</b>
12 x 12	150	12	8.0	<b>2405-K-1280</b>

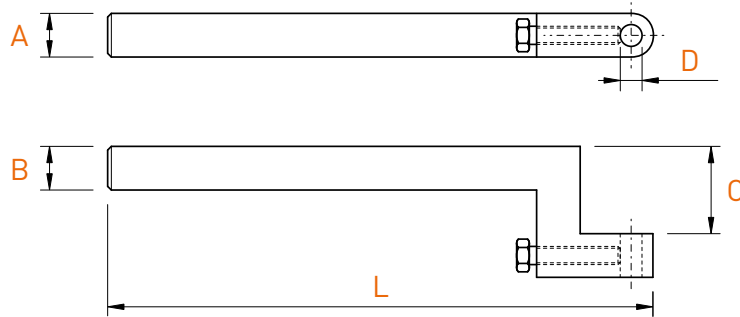

A x B	L	C	D	Art. N°
8 x 8	120	12	4.0	<b>2425-8124</b>
8 x 8	120	15	5.0	<b>2425-8155</b>
8 x 8	120	20	5.0	<b>2425-8205</b>
10 x 10	100	15	6.0	<b>2425-10156</b>
10 x 10	100	20	6.0	<b>2425-10206</b>
12 x 12	150	18	6.0	<b>2425-12186</b>
12 x 12	150	24	8.0	<b>2425-12248</b>

# TOOLING-Line

Porte-outils

Werkzeughalter

Tool holders

12 x 16

2441

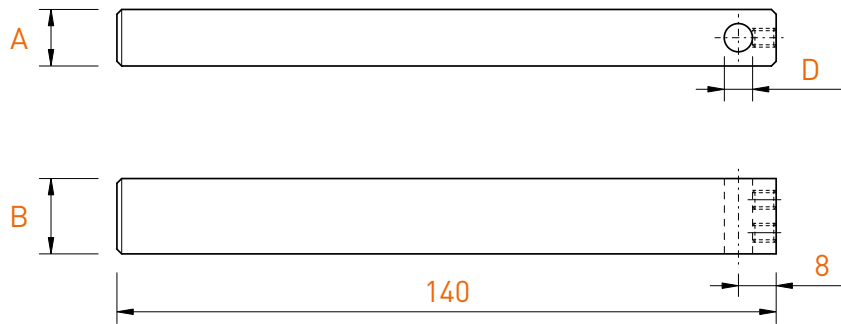

A x B	D	Art. N°
12 x 16	3.0	2441-0-3
12 x 16	4.0	2441-0-4
12 x 16	5.0	2441-0-5
12 x 16	6.0	2441-0-6

Porte-outils

Werkzeughalter

Tool holders

∅ 16 x 16

2440-0

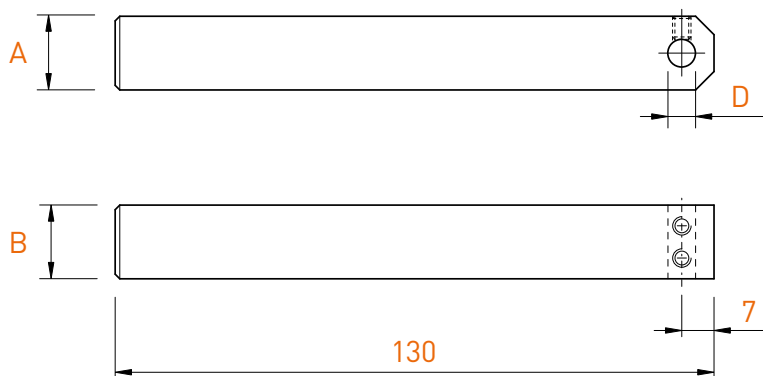

A x B	D	Art. N°
16 x 16	3.0	2440-0-3
16 x 16	4.0	2440-0-4
16 x 16	5.0	2440-0-5
16 x 16	6.0	2440-0-6

Porte-outils

Werkzeughalter

Tool holders

∅ 16 x 16

2440-8 / 2440-12

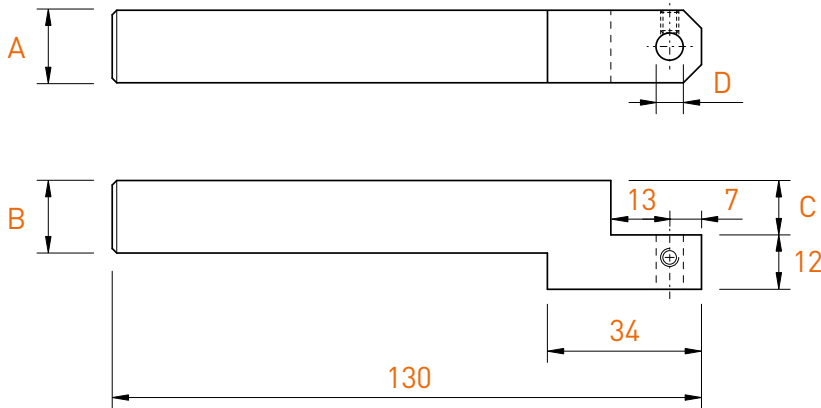

A x B	C	D	Art. N°
16 x 16	8	3.0	2440-8-3
16 x 16	8	4.0	2440-8-4
16 x 16	8	5.0	2440-8-5
16 x 16	8	6.0	2440-8-6
16 x 16	8	8.0	2440-8-8
16 x 16	12	3.0	2440-12-3
16 x 16	12	4.0	2440-12-4
16 x 16	12	5.0	2440-12-5
16 x 16	12	6.0	2440-12-6
16 x 16	12	8.0	2440-12-8

Porte-outils

Werkzeughalter

Tool holders

∅ 16 x 16

2440-18 / 2440-26

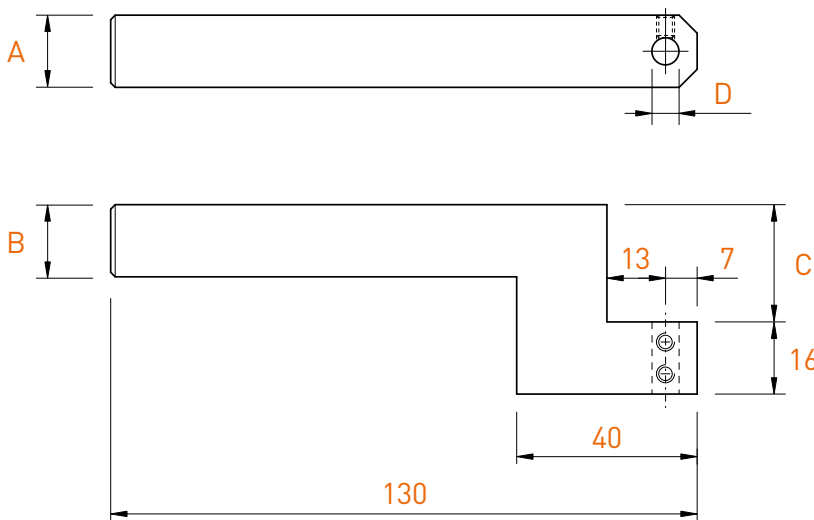

A x B	C	D	Art. N°
16 x 16	18	4.0	2440-18-4
16 x 16	18	5.0	2440-18-5
16 x 16	18	6.0	2440-18-6
16 x 16	18	8.0	2440-18-8
16 x 16	26	4.0	2440-26-4
16 x 16	26	5.0	2440-26-5
16 x 16	26	6.0	2440-26-6
16 x 16	26	8.0	2440-26-8

# TOOLING-Line

Porte-outils pour machines Tornos DECO 7/10

Werkzeughalter für Tornos DECO 7/10 Maschinen

Tool holders for Tornos DECO 7/10 machines

2435 / 2435-T

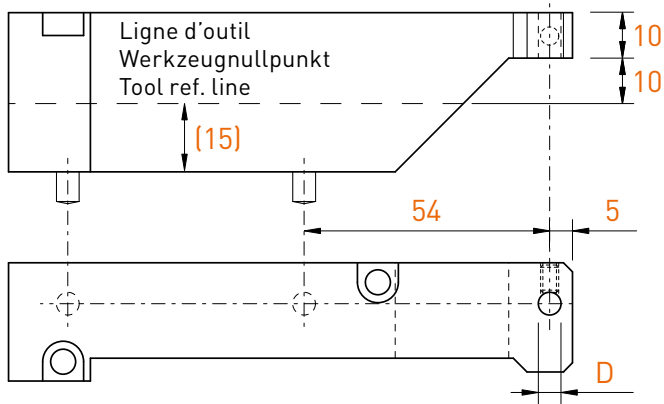

D	Art. N°
3.0	2435-3
4.0	2435-4
5.0	2435-5
6.0	2435-6

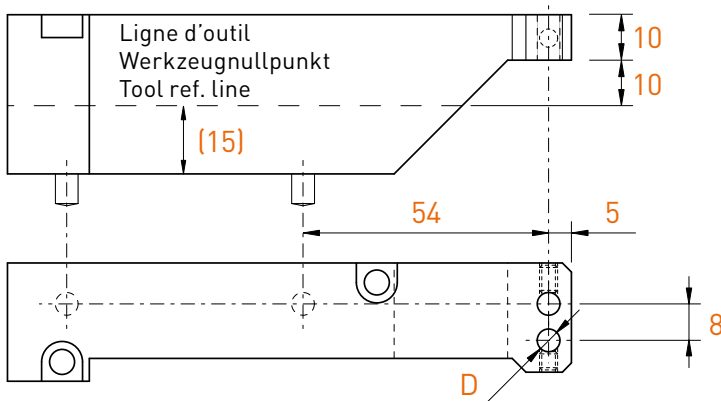

D (2x)	Art. N°
3.0	2435-3-T
4.0	2435-4-T
5.0	2435-5-T
6.0	2435-6-T

Porte-outils pour machines Tornos DECO 13 / EvoDECO 16

Werkzeughalter für Tornos DECO 13 / EvoDECO 16 Maschinen

Tool holders for Tornos DECO 13 / EvoDECO 16 machines

## 2436 / 2436-T

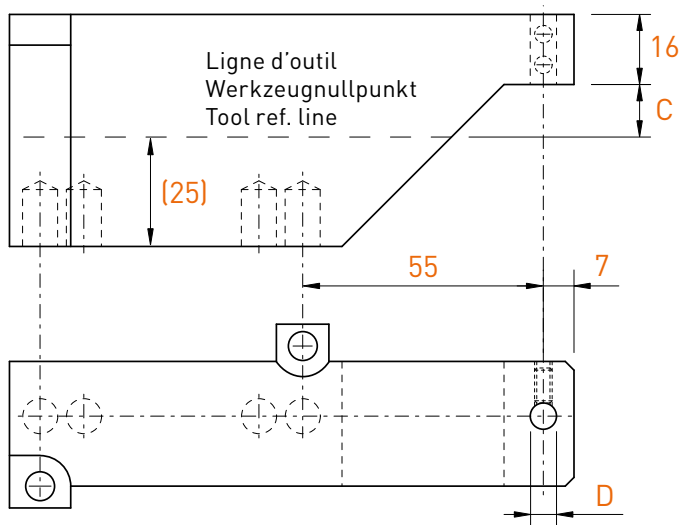

C	D	Art. N°
12	3.0	2436-12-3
12	4.0	2436-12-4
12	5.0	2436-12-5
12	6.0	2436-12-6
12	8.0	2436-12-8
18	3.0	2436-18-3
18	4.0	2436-18-4
18	5.0	2436-18-5
18	6.0	2436-18-6
18	8.0	2436-18-8

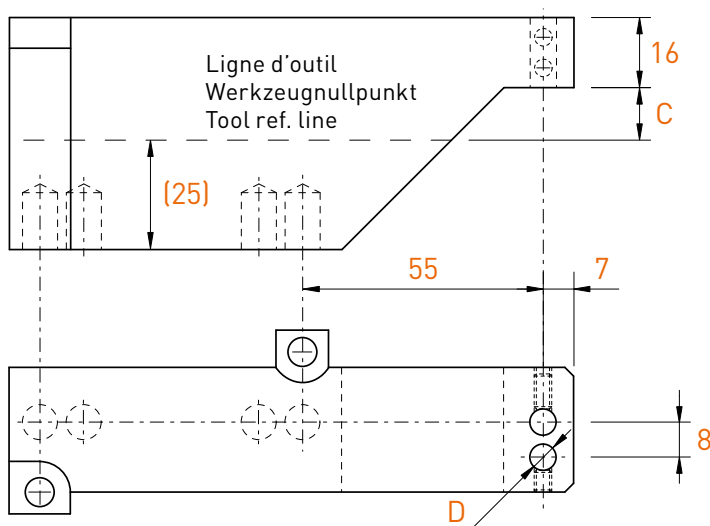

C	D (2x)	Art. N°
12	3.0	2436T-12-3
12	4.0	2436T-12-4
12	5.0	2436T-12-5
12	6.0	2436T-12-6
18	3.0	2436T-18-3
18	4.0	2436T-18-4
18	5.0	2436T-18-5
18	6.0	2436T-18-6

Entretoise

Erhöhungplatte

Spacer

## 2436-S12

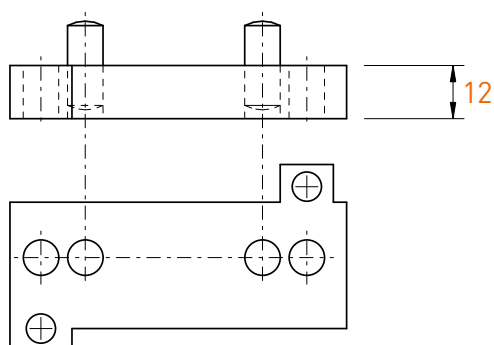

Art. N°

2436-S12

# TOOLING-Line

Forets à centrer plats

Zentrierflachbohrer

Centering flat drills

90°

1200 / 2200

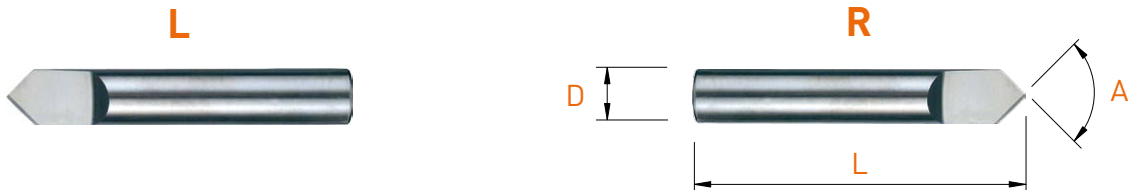

MD VHM HM			L	R
A	D	L	Art. N°	Art. N°
90°	3	17	1200-317	2200-317
90°	3	38	1200-338	2200-338
90°	4	40	1200-440	2200-440
90°	5	50	1200-550	2200-550
90°	6	50	1200-650	2200-650
90°	8	58	1200-858	2200-858
90°	10	66	1200-1066	2200-1066
90°	12	73	1200-1273	2200-1273



Forets à centrer hélicoïdaux

Zentrierspiralbohrer

Centering twist drills

90°

1500 / 2520

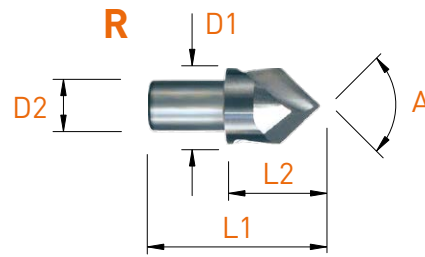

					HSS		MD / VHM / HM	
					L	R	L	R
A	D1	D2	L1	L2	Art. N°	Art. N°	Art. N°	Art. N°
90°	5	4	17	8	1500-5-HSS	2520-5-HSS	1500-5	2520-5
90°	7	5	17	8	1500-7-HSS	2520-7-HSS	1500-7	2520-7
90°	10	6	22	10	1500-10-HSS	2520-10-HSS	1500-10	2520-10
90°	12	8	26	12	1500-12-HSS	2520-12-HSS	1500-12	2520-12

Forets à centrer hélicoïdaux

Zentrierspiralbohrer

Centering twist drills

120°

1510 / 2530

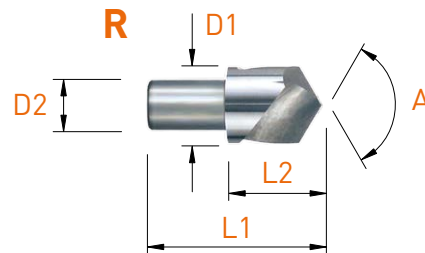

					MD VHM HM		L	R
A	D1	D2	L1	L2	Art. N°	Art. N°		
120°	5	4	17	8	1510-5	2530-5		
120°	7	5	17	8	1510-7	2530-7		
120°	10	6	22	10	1510-10	2530-10		
120°	12	8	26	12	1510-12	2530-12		

# TOOLING-Line

Burins intérieurs en métal dur

Vollhartmetall Innendrehwerkzeuge

Solid carbide internal turning tools

1600 / 2620

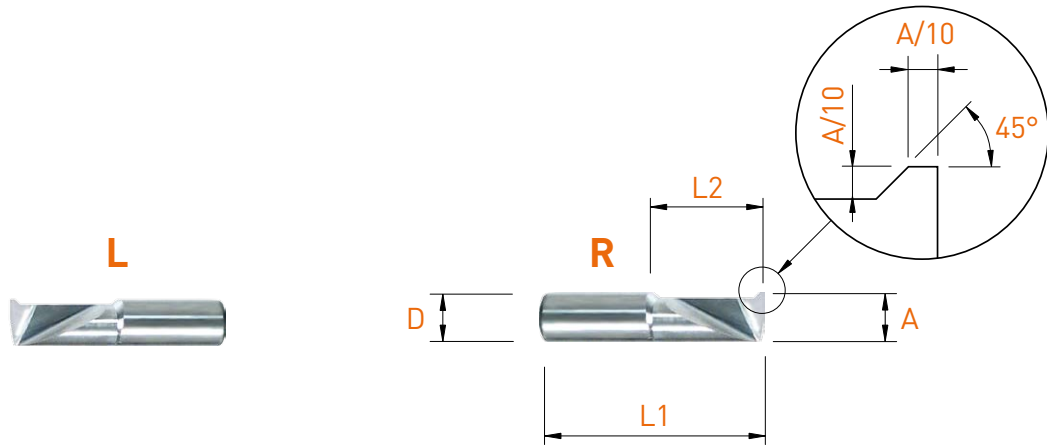

MD VHM HM				L	R
A -0.05	D	L1	L2	Art. N°	Art. N°
2	3	13	4	1600-2-4	2620-2-4
3	3	15	6	1600-3-6	2620-3-6
4	4	17	8	1600-4-8	2620-4-8
4	4	21	12	1600-4-12	2620-4-12
5	5	21	10	1600-5-10	2620-5-10
5	5	26	15	1600-5-15	2620-5-15
6	6	25	12	1600-6-12	2620-6-12
6	6	31	18	1600-6-18	2620-6-18
8	8	32	16	1600-8-16	2620-8-16
8	8	40	24	1600-8-24	2620-8-24

**Burins intérieurs en métal dur**  
**Vollhartmetall Innendrehwerkzeuge**  
**Solid carbide internal turning tools**

**1610 / 2630**

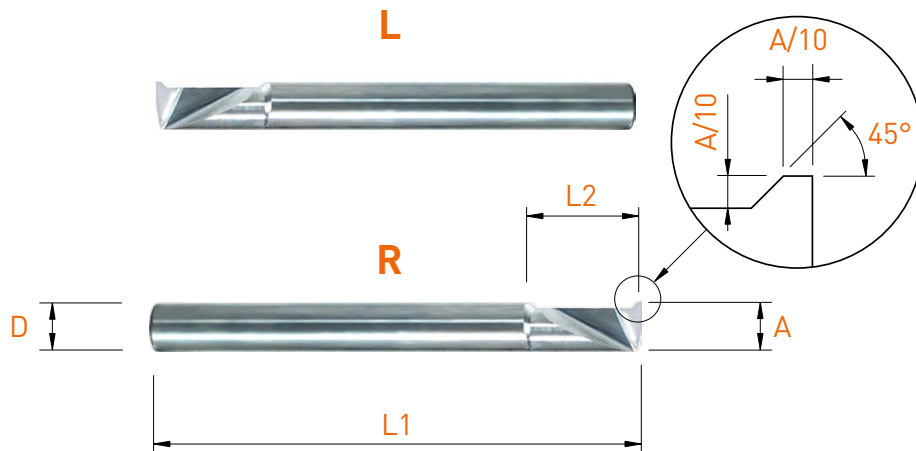

MD VHM HM				L	R
A -0.05	D	L1	L2	Art. N°	Art. N°
2	3	38	4	<b>1610-2-4</b>	<b>2630-2-4</b>
3	3	38	6	<b>1610-3-6</b>	<b>2630-3-6</b>
4	4	40	8	<b>1610-4-8</b>	<b>2630-4-8</b>
4	4	40	12	<b>1610-4-12</b>	<b>2630-4-12</b>
5	5	50	10	<b>1610-5-10</b>	<b>2630-5-10</b>
5	5	54	15	<b>1610-5-15</b>	<b>2630-5-15</b>
6	6	50	12	<b>1610-6-12</b>	<b>2630-6-12</b>
6	6	57	18	<b>1610-6-18</b>	<b>2630-6-18</b>
8	8	58	16	<b>1610-8-16</b>	<b>2630-8-16</b>
8	8	63	24	<b>1610-8-24</b>	<b>2630-8-24</b>
10	10	72	30	-	<b>2630-10-30</b>
12	12	83	36	-	<b>2630-12-36</b>

# TOOLING-Line

Porte-molettes

Rändelhalter

Knurl holders

1402 / 2402

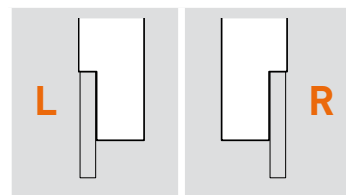
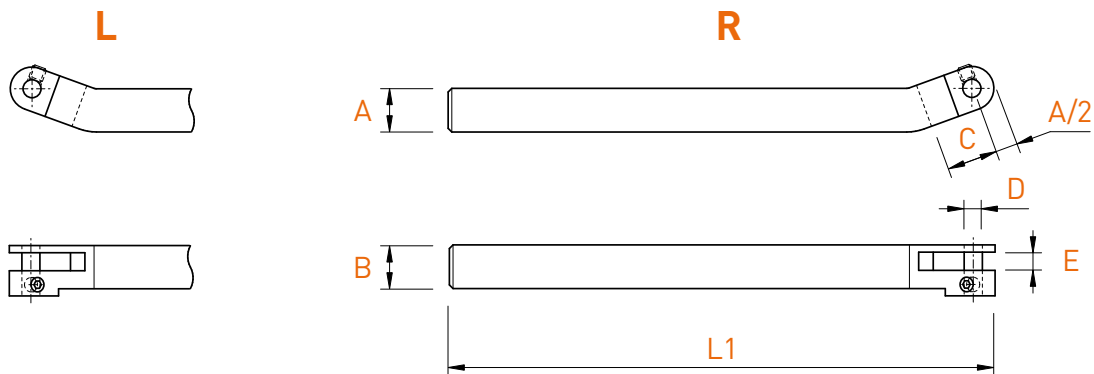

A x B	L	E	D	C	A/2	Art. N°	Art. N°
6 x 6	132	2	3	10	3	1402-623	2402-623
6 x 6	132	3	3	10	3	1402-633	2402-633
7 x 7	140	2	3	10	3.5	1402-723	2402-723
7 x 7	140	3	3	10	3.5	1402-733	2402-733
7 x 7	140	4	3	10	3.5	1402-743	2402-743
7 x 7	140	2	4	10	3.5	1402-724	2402-724
7 x 7	140	3	4	10	3.5	1402-734	2402-734
7 x 7	140	4	4	10	3.5	1402-744	2402-744
8 x 8	140	2	3	10	4	1402-823	2402-823
8 x 8	140	3	3	10	4	1402-833	2402-833
8 x 8	140	4	3	10	4	1402-843	2402-843
8 x 8	140	2	4	10	4	1402-824	2402-824
8 x 8	140	3	4	10	4	1402-834	2402-834
8 x 8	140	4	4	10	4	1402-844	2402-844
10 x 10	150	3	3	10	5	1402-1033	2402-1033
10 x 10	150	4	3	10	5	1402-1043	2402-1043
10 x 10	150	3	4	10	5	1402-1034	2402-1034
10 x 10	150	4	4	10	5	1402-1044	2402-1044
10 x 10	150	5	4	10	5	1402-1054	-
12 x 12	150	4	4	12	6	1402-1244	2402-1244
12 x 12	150	5	4	12	6	1402-1254	2402-1254
12 x 12	150	4	5	12	6	1402-1245	2402-1245
12 x 12	150	5	5	12	6	1402-1255	2402-1255
16 x 16	150	4	4	12	8	1402-1644	2402-1644
16 x 16	150	4	5	12	8	-	2402-1645
16 x 16	150	5	5	12	8	-	2402-1655
16 x 16	150	6	4	12	8	-	2402-1664
16 x 16	150	6	6	12	8	-	2402-1666
16 x 16	150	8	6	12	8	-	2402-1686

Molettes en métal dur

Vollhartmetall Rändelrädchen

Solid carbide knurling wheels

1107

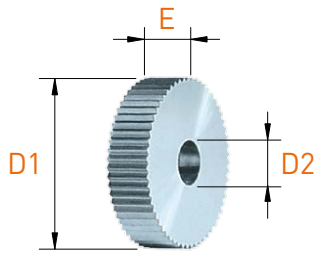

AA

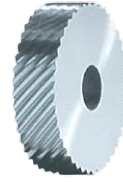

BL

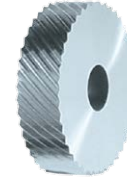

BR

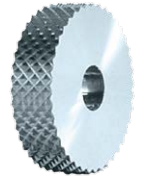

GE

Molettes standards Standard Rändelrädchen Standard knurls	D1	E	D2	Pas (tous les 0.1 mm) Teilung (alle 0.1 mm) Pitch (every 0.1 mm)	
AA (0°)	8	2	3	0.2 - 0.6	
	8	2	4	0.2 - 0.6	
	8	3	3	0.2 - 0.6	
	8	3	4	0.2 - 0.6	
	8	4	3	0.2 - 0.6	
	8	4	4	0.2 - 0.6	
	10	2	3	0.2 - 0.8	
	10	2	4	0.2 - 0.8	
	10	3	3	0.2 - 0.8	
	BL 15° / BR 15° BL 30° / BR 30° BL 45° / BR 45°	10	3	4	0.2 - 0.8
		10	4	3	0.2 - 0.8
		10	4	4	0.2 - 0.8
	GE 30° GE 45°	12	4	4	0.3 - 1.0
		15	4	4	0.4 - 1.0
		15	4	5	0.4 - 1.0
		15	5	4	0.4 - 1.0
		15	5	5	0.4 - 1.0
		20	4	5	0.5 - 1.2
20		5	5	0.5 - 1.2	
20		6	6	0.5 - 1.2	
20	8	6	0.5 - 1.2		

Molettes "Quick" "Quick"-Rändelrädchen "Quick"-knurling wheels	D1	E	D2	Pas (tous les 0.1 mm) Teilung (alle 0.1 mm) Pitch (every 0.1 mm)
AA (0°)	8.9	2.5	4	0.2 - 0.8
BL 15° / BR 15°	14.5	3	5	0.4 - 1.0
BL 30° / BR 30°	21.5	5	8	0.5 - 1.2

Exécutions spéciales sur demande  
Sonderausführungen auf Anfrage  
Special executions on request

# MICRO-Line

Micro-fraises de précision  
Micropräzisionsfräser  
Precision micro end mills

Fraises en bout de finition  
Schlicht Schaftfräser  
Finishing end mills

Fraises à graver  
Gravierfräser  
Engraving mills

Micro-forets et centreurs  
Microbohrer und Zentrierbohrer  
Micro drills and centering drills



# CIRCO-Line

Fraises circulaires MD et tasseaux  
VHM-Kreissägen und Fräsdorne  
Solid carbide slitting saws and arbors

BROCHURES DE NOS GAMMES DE PRODUITS  
BROSCHÜREN VON UNSEREN PRODUKTREIHEN  
BROCHURES OF OUR PRODUCTS LINES



**TOP-Line**



**TOP-Watch**

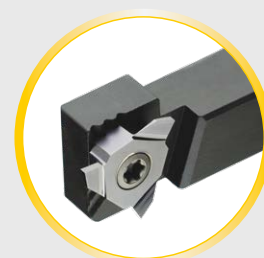

**TRIO-Line**

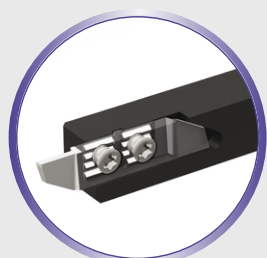

**PRO-Line**



**ECO-Line**



**ISO-Line**



**CUT-Line**



**TURN-Line**



**MODU-Line**



**IN-Line**



**MICRO-Line**



**CIRCO-Line**



PERFORMANCE | PRECISION | RIGIDITY



SWISS MADE



**APPLITEC**  
SWISS TOOLING

**Applitec Moutier S.A.**  
Ch. Nicolas-Junker 2  
CH-2740 Moutier

Tél. +41 32 494 60 20  
Fax +41 32 493 42 60  
[www.applitec-tools.com](http://www.applitec-tools.com)