

HOME OF CLAMPING



2023/2024
ZERO-POINT-SYSTEMS

WE GENERATE EXCITEMENT.

Since the foundation of the company in 1890 until today the goal has remained the same: the highest quality in products and services. Nevertheless, the circumstances, tasks and challenges have changed, of course. By focussing on our core areas of expertise, we have long set new standards for innovative clamping technology - driven by our own development, the greatest possible flexibility and passion for individual solutions.

All this is only possible with committed and contented employees. Respectful interaction with others, personal development and measures for the wellbeing of each individual are therefore values that matter to us.



Company Management:
Wolfgang Balle, Johannes Maier (CEO), Jürgen Förster

OUR COMPANY HISTORY

- 1890 Company founded as a lock manufacturer by Andreas Maier.
- 1920 Product range extended to include spanners.
- 1928 Production line assembly of FELLBACH LOCKS.
- 1951 Introduces clamping elements and diversifies into workpiece and tool clamping technology.
- 1965 Toggle clamps extend the AMF product range, AMF catalogues are now printed in ten languages.
- 1975 Further specialisation into hydraulic clamping technology.
- 1982 Clamping and fixture systems round off AMF's clamping expertise.
- 1996 AMF team organisation in all sectors of the business, Quality management with certification to ISO 9001.
- 2001 AMF Service Guarantee for all products.
- 2004 Introduction of the ZPS zero-point clamping system.
- 2007 The magnetic clamping technology extends the AMF product range.
- 2009 Development and marketing of AMF Vacuum clamping technology.
- 2012 LOW-COST AUTOMATION gripping, clamping, marking and cleaning.
- 2014 AMF presents the most extensive product range of automation solution in zero-point clamping technology.
- 2017 Wireless sensing systems extend the expertise into Industry 4.0 and blends seamlessly into the AMF product range.

PLEDGES THAT COUNT IN EVERYDAY LIFE

For this reason, we have a few principles that we follow by conviction and which always apply..

INDIVIDUAL DEVELOPMENT

Even if the product you need does not even exist yet, we will find the right solution with you: from special designs to new developments, everything is possible.

WARRANTY

If, despite our high quality standard, there is a complaint, this is dealt with quickly and unbureaucratically, even beyond the warranty period.

HIGHEST QUALITY STANDARDS

Careful manufacturing based on tradition since 1890, and naturally with a modern quality management system according to ISO 9001 for many years.

SHORT DELIVERY TIME

With over 5,000 articles in our warehouse, you can expect your order to be dispatched on the same day.

COMPETENT SERVICE FROM EXPERTS

Your local retail partner or the specialists in our team will find the right solution for every task.

MADE IN GERMANY

Our entire product range is developed and manufactured exclusively by our employees in Germany.

INSTALLATION CLAMPING MODULES

14 - 30



SURFACE-MOUNTING CLAMPING MODULES

31 - 35



AUTOMATION MODULES

36 - 53



MECHANICAL CLAMPING MODULES

54 - 61



MODULAR ZERO-POINT CLAMPING SYSTEM

62 - 93



CLAMPING STATION AND CLAMPING BRACKET QUICK-CHANGE PALLETS

94 - 121

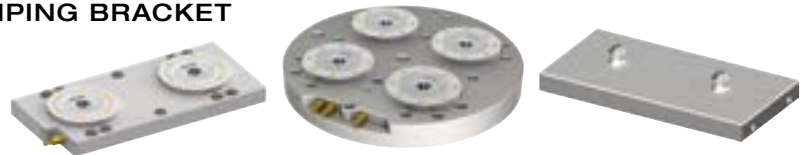

PULL-STUDS AND ENGAGEMENT SCREWS

122 - 137



ACCESSOIRES

138 - 155

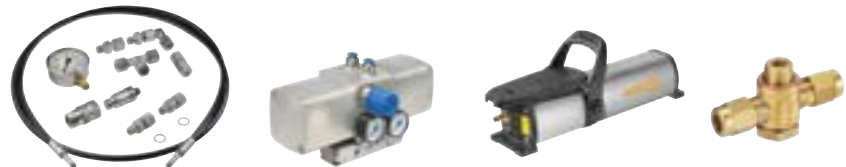

FIELD APPLICATIONS

156 - 199

CLAMPING MODULES GONZALES AND UNITOOL FOR CONVERSION OF EXISTING CLAMPING SYSTEMS

200 - 206



NEW!

INSERTION TOOL

For sizes SP140 and SP150.
No. 6203ZMW, page 138



NEW!

ZERO-POINT CLAMPING SLEEVE

No. 6214ZN-250-03, page 123



NEW!

CLAMPING MODULE WITH LOCKING FUNCTION, MECHANICAL, SCREW-IN VERSION

No. 6214RM-251, page 55



NEW!

CLAMPING MODULE, SCREW-IN VERSION, SHORT DESIGN

No. 6215RP-251, page 16



NEW!

INSTALLATION CLAMPING MODULE, SCREW-IN VERSION

NEW! Size SP140
No. 6203SP, page 17



PULL-STUD SIZE 140

No. 6203ZN-140, page 125



NEW!

NEW!

INSERTION TOOL

For sizes KP5 and KH5.
No. 6370ZMW-5, page 138



**PULL-STUD FOR
ENGAGEMENT SCREW
WITHOUT FITTING COLLAR**

No. 6370ZNF-10 + 6370ZNF-20, page 133



NEW!

PROTECTIVE CAP

No. 6370ZSS-04, page 153

ENGAGEMENT SCREW

No. 6370ZNSF, page 133



NEW!

**ADAPTER WITH
STRAIGHT CLAMP**

No. 6210AGS, page 76



**INSTALLATION CLAMPING MODULE
FOR AUTOMATION SOLUTIONS,
SCREW-IN VERSION**

No. 6103LA-5, page 40



**INSTALLATION CLAMPING MODULE
FOR AUTOMATION SOLUTIONS**

No. 6108LA-XX-08, page 41
New size!



ECONOMICAL, PRECISE, QUICK - THE AMF ZERO-POINT SYSTEM

By using modern AMF zero-point systems, you optimize fixture and workpiece changeover in your production, correspondingly reduce set-up times on the machine and so save money!

The benefits of zero-point clamping technology are obvious:

- > Increase in machine run-time
- > Very fast workpiece or fixture changeover
- > High repeatability
- > A uniform interface for all machines
- > Positioning and clamping in a single step





> The pull-stud in our zero-point system is the interface between the machine table and the workpiece or fixture. It ensures exact positioning and secure clamping. The resulting work forces are transferred through the pull-stud to the clamping module.

> The precisely manufactured clamping modules of the AMF Zero-Point System ensure a secure and firm hold of the workpiece or fixture to be clamped. With the high pull-in, closing and holding forces, they are suitable for every application.



Subject to technical alterations.



LARGE INTAKE CATCHMENT

No laborious searching for the holes anymore - self-centring via the diagonal side surfaces of the engagement screw.



SWING-FREE

Swing-free run-in and run-out through the optimal contour of the pull-stud.



FORM FIT

The balls are optimally encapsulated on 3 sides. As a result, the pull-stud always remains firmly clamped in the module.

YOUR ADVANTAGES - THOUGHT THROUGH IN DETAIL

Experience a zero point clamping system that, through its innovative and forward-looking features, presents its strengths in use in an advanced way.

Numerous advantages speak for themselves and make the AMF zero-point system into a technology that revolutionizes the zero-point clamping technology market.



SIMPLE CLEANING

Our zero-point clamping systems can be blown out very simply with a commercially available compressed air cleaning pistol and do not require complicated suctioning out.



BLOW OUT

Our system has a pneumatic blow-out installed at the factory. As a result, chips and dirt inside are effectively blown out.



RUSTPROOF STAINLESS STEEL

High-alloy, hardened tool steel - and so no corrosion.



THREE-POINT PRINCIPLE

Power transmission by means of the three-point principle! This optimised force distribution prevents shearing load on the balls.



MEDIA FEED

Due to the lateral media feed, low pallet thicknesses are possible and fewer feed holes are necessary.



NO BALL CAGE

The balls lie freely in the ball canal. This freedom of movement enables the balls to continuously re-position themselves.



LARGE BALL DIAMETER

Ball surface is 784% greater than with traditional ball systems.



SAFETY SYSTEM

Process reliability - Clamping module always opens. A piston blockade is thus impossible.

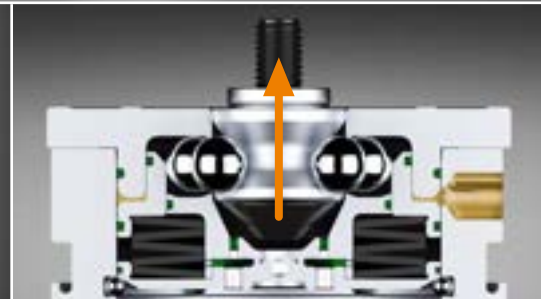

GOOD HOLDING, PULL-IN AND LOCKING FORCES

Holding force of up to 105 kN*. Pull-in and locking force of up to 40 kN.

* Please observe the installation instructions.

Subject to technical alterations.

FAQS ABOUT ZERO-POINT CLAMPS AND THE AMF ZERO-POINT SYSTEM

ARE SUBJECT TO THE AMF ZERO-POINT CLAMPING MODULE DEFINED IN STANDARD DIN EN ISO 13849?

- > Yes, the AMF zero-point clamping modules in sizes KP, KH and BM were designed using the fundamental and proven safety principles defined in EN ISO 13849-2, Table A.1 and A.2 or B.1 and B.2, or Table C.1 and C.2. The user is obliged to comply with these safety principles during the implementation and operation of our products.

WHAT IS PULL-IN FORCE / HOLDING FORCE?

- > The pull-in force describes the force with which the stud is pulled in and clamped with positive interlocking in the clamping module. The holding force, in contrast, specifies the maximum permissible pull force of the engagement screw.

WHAT IS REPEATABILITY?

- > The repeatability specifies the tolerance range within which the recorded reference points on the workpiece lie after removal and reclamping of the same workpiece. The repeatability, also called repetition accuracy, is below 0.005mm.

WHAT ADVANTAGES RESULT FROM THE USE OF ZERO-POINT, TIMING AND UNDERSIZE PULL-STUDS?

- > These different types of pull-studs offset the spacing tolerances of pull-studs and clamping modules. The fixed reference point is achieved through the zero-point pull-stud; the slit pull-stud serves to compensate for the still-free axis. The under size pull-stud does not have a centring function, but only a clamping and holding function.



CAN I INSERT THE PULL-STUD DIRECTLY INTO THE WORKPIECE FOR MACHINE PROCESSING?

- > The high costs for chucking fixtures and workpiece clamping can be effectively saved here if the pull-studs are mounted in the workpiece, which is clamped directly using the clamping modules. As a result, a complete 5-sided processing of the workpiece is possible in one chucking. With the different stud sizes (attaching thread M6 to M16), workpieces of different sizes can be clamped.

HOW DOES THE SYSTEM COMPENSATE FOR HEAT, SUCH AS FROM METAL CUTTING?

- > Through the different pull-stud designs, the system can compensate for temperature differences between the workpiece and the clamping module easily and controllably. For a graphic depiction of the stud array, see page 124 of the catalogue. If you have other technical questions, please contact us at any time.



WHAT SHOULD BE THE SPACING TOLERANCE OF THE PULL-STUDS AND THE CLAMPING MODULES IF SELF-PRODUCED?

- > The permissible spacing tolerance of pull-studs and clamping modules is +/- 0.01 mm.

WHERE CAN I GET AN INSTALLATION DIAGRAM OR INSTALLATION MANUAL?

- > We are happy to send them immediately when customers request them by e-mail.

IS THE CLAMPING MODULE SUITABLE FOR ERODING?

- > The module is optimally suited for all normal processes, such as eroding, grinding, cutting and turning. Through the complete sealing, the clamping module can be used in liquids and under rough ambient conditions.

IS THE CLAMPING MODULE SUITABLE FOR USE ON INJECTION MOULDING MACHINES?

- > Especially when injection moulds are changed frequently, the costs for a zero-point solution are amortized within the shortest of times for such machines. Unlike with mechanical clamps, clamping takes place quickly and easily just by pressing a button.

HOW HIGH IS THE MAX. OPERATING TEMPERATURE OF THE CLAMPING MODULES?

- > The maximum processing temperature is 80°C in the standard design. Clamping modules for use at higher temperatures can be requested at any time.

WHAT IS BLOW-OUT AND HOW DOES IT WORK?

- > Blow-out using compressed air is guided through the floor of the clamping module and blows out contamination, such as chips, coolant or the like from the central opening and from the sphere space of the module.

WHEN DO I USE THE HYDRAULIC PRESSURE INTENSIFIER AND WHEN THE PNEUMATIC PRESSURE INTENSIFIER?

- > Hydraulic pressure intensifier: This transforms the pneumatic into hydraulic pressure in a ratio of 1:8 to open hydraulic modules. Pneumatic pressure intensifier: This is used to intensify the pneumatic pressure in the ratio of 1:2 for pneumatic clamping modules and compensates for pressure fluctuations in the supply line.

HOW DOES THE PATENTED SAFETY SYSTEM WORK IN THE HYDRAULIC CLAMPING MODULE AND WHEN IS IT USED?

- > If the piston seal begins to leak, the spring space quickly fills with oil. The result is: The piston blocks and the module can no longer be opened. Destruction of the clamped fixture of the of clamping module would then be unavoidable. Here, the patented safety system ensures that the oil in the spring space can escape and the piston can be operated.

ARE YOU PRODUCING YET OR STILL SETTING UP?

THE CALCULATION IS VERY SIMPLE!

It has been shown that you can reduce your set-up times by over 90% through the use of the AMF Zero-Point System. High machine standstill times are avoided, set-up times minimized and cash saved...

Take the time to calculate your savings potential with the AMF Zero-Point System very simply.

SAMPLE CALCULATION OF A CUSTOMER BEFORE AND AFTER USE OF THE ZERO-POINT SYSTEM

Procedure	Without zero-point clamping system	With the AMF Zero Point System
Machine costs	€100/h	€100/h
Number of set-ups per shift (8h)	4 x	4 x
Set-up time per procedure	30 mins.	2 mins.
Set-up time per shift (8h)	120 mins. (2 h)	8 mins. (0,13 h)
Set-up costs per shift (8h)	€ 200	€ 13
Set-up costs per shift each year (250 working days)	€ 50.000	€ 3.250
Annual savings per shift (8h)	€46.750	

DRASTICALLY REDUCED SET-UP TIMES GUARANTEE YOU WILL EXPERIENCE A RAPID RATIONALISATION EFFECT

If previously 120 mins had to be invested in four tooling procedures in a shift, the use of the AMF Zero Point System will reduce this to only 8 mins. Rapid switching of equipment and workpieces as well as tooling in parallel with operating time outside of the machine results in the rationalisation effect described.

The savings in our customer example of €140.250 per year, for three-shift production utilisation, guarantees rapid amortisation of the invested amounts of approx. €3,750 for a 4-capacity clamping station including accessories.

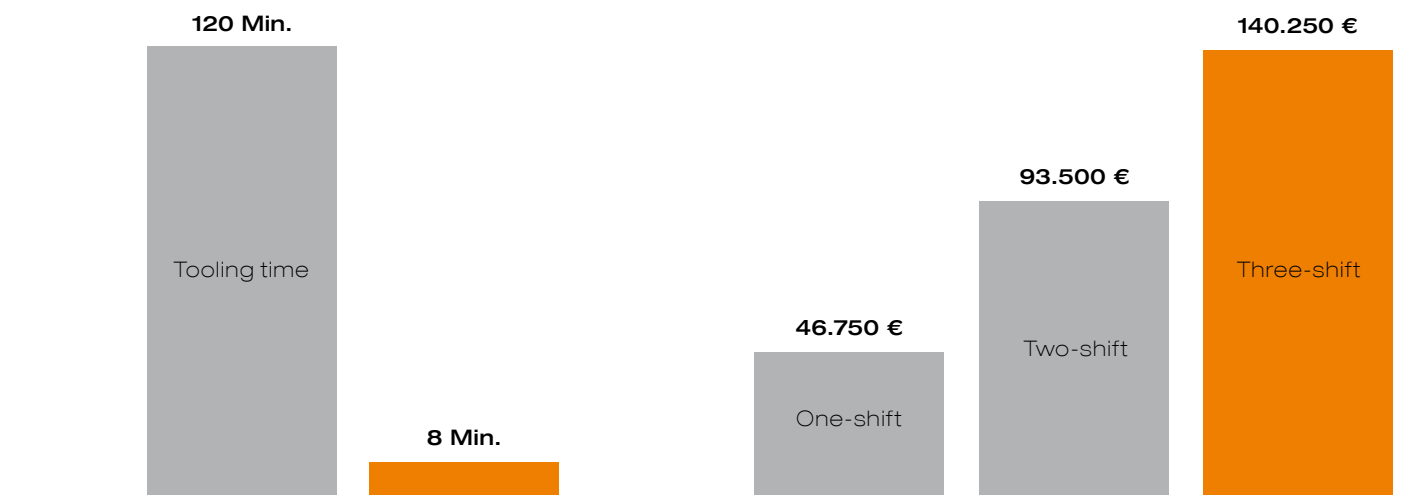

Tooling times drastically reduced from 120 mins to 8 mins - through the use of the AMF Zero Point System.

Whether one, two or three-shift operation - the savings from the AMF Zero Point System speak for themselves!

COLOUR CODING SYSTEM FOR HYDRAULIC AND PNEUMATIC CLAMPING MODULES.

Table portion with bright ORANGE background: Open hydraulically!

Table portion with bright BLUE background: Open pneumatically!

	RP250 RP251	SP140	SP150	KH5	KP5	KP5.3	KH10	KP10	KH10.2	KP10.3
	pneum.	pneum.	pneum.	hydr.	pneum.	pneum.	hydr.	pneum.	hydr.	pneum.
Pull-in/locking force in the system up to [kN]	0,1	0,07	0,23	5,0	1,5	1,5	10,0	8,5	10,0	10,0
Holding force* [kN]	1,0	0,5	6,0	13,0	13,0	13,0	25,0	25,0	25,0	25,0
Service according to ... clamping cycles* [St]	2.000.000	100.000	2.500.000	250.000	2.000.000	4.000.000	2.500.000	400.000	2.500.000	4.000.000
Min./max. operating pressure for opening [bar]	5 / 12	6 / 12	6 / 14	50 / 60	8 / 12	5 / 12	50 / 60	8 / 12	50 / 60	5 / 12
Min./max. operating pressure for reclamping [bar]	-	-	-	-	5 / 6	-	-	5 / 6	-	-
Opening volume [cm³]	0,5	0,2	1,0	1,5	1,5	5,0	3,0	3,0	3,0	17,0
Pre-positioning [mm]	1,0	1,0	1,0	4,0	4,0	4,0	6,5	6,5	6,5	6,5
Repeatability [mm]	< 0,1	< 0,02	< 0,02	< 0,005	< 0,005	< 0,005	< 0,005	< 0,005	< 0,005	< 0,005

	KH20	KP20	KP20.3	KH20.3	KH40	KP40	Horizontal KH20	Horizontal KH40	Kompakt KH10
	hydr.	pneum.	pneum.	hydr.	hydr.	pneum.	hydr.	hydr.	hydr.
Pull-in/locking force in the system up to [kN]	20,0	17,0	17,0	30,0	40,0	30,0	20	40	1,3
Holding force* [kN]	55,0	55,0	55,0	55,0	105,0	105,0	55	105	25
Service according to ... clamping cycles* [St]	1.500.000	150.000	4.000.000	1.000.000	100.000	150.000	1.500.000	100.000	150.000
Min./max. operating pressure for opening [bar]	50 / 60	8 / 12	4,5 / 12,0	60 / 70	50 / 60	8 / 12	50 / 60	50 / 60	50 / 60
Min./max. operating pressure for reclamping [bar]	-	5 / 6	-	-	-	5 / 6	-	-	-
Opening volume [cm³]	10,0	10,0	37,0	10,0	27,0	27,0	10,0	27,0	3,5
Pre-positioning [mm]	12,0	12,0	12,0	12,0	12,0	12,0	11,0	11,0	4,0
Repeatability [mm]	< 0,005	< 0,005	< 0,005	< 0,005	< 0,005	< 0,005	< 0,005	< 0,005	< 0,005

* Please observe the installation instructions.

Subject to technical alterations.



INSTALLATION CLAMPING MODULES

The AMF installation clamping modules are used with low space requirement and low overall height. For installation in pallets, machine tables, clamping brackets and cubes. Usable when cutting, grinding, eroding and on plastic-processing machines as well as for fixture construction with mounting fixtures and handling systems. The AMF clamping modules can be installed in all positions. Whether vertical or overhead - mounting works completely without assembly tools.

Installation clamping modules come in 13 different sizes:

- > **Clamping modules RP250** - Ø 22 mm
Insertion/locking force up to 0,1 kN - holding force 1 kN*
- > **Clamping modules RP251** - Ø 22,4 mm
Insertion/locking force up to 0,1 kN - holding force 1 kN*
- > **Clamping modules SP140** - Ø 15 mm
Insertion/locking force up to 70 N - holding force 500 N*
- > **Clamping modules SP150** - Ø 22 mm
Insertion/locking force up to 0,23 kN - holding force 6 kN*
- > **Clamping modules KP5 / KH5** - Ø 45 mm
Insertion/locking force up to 5 kN - holding force 13 kN*
- > **Clamping modules KP5.3** - Ø 78 mm
Insertion/locking force up to 1,3 kN - holding force 13 kN*
- > **Clamping modules KP10 / KH10** - Ø 78 mm
Insertion/locking force up to 10 kN - holding force 25 kN*
- > **Clamping modules KH10.2** - Ø 112 mm
Insertion/locking force up to 10 kN - holding force 25 kN*
- > **Clamping modules KP10.3** - Ø 112 mm
Insertion/locking force up to 10 kN - holding force 25 kN*
- > **Clamping modules KH20 / KP20** - Ø 112 mm
Insertion/locking force up to 20 kN - holding force 55 kN*
- > **Clamping modules KP20.3** - Ø 138 mm
Insertion/locking force up to 17 kN - holding force 55 kN*
- > **Clamping modules KP20.4** - Ø 112 mm
Insertion/locking force up to 30 kN - holding force 55 kN*
- > **Clamping modules KP40 / KH40** - Ø 148 mm
Insertion/locking force up to 40 kN - holding force 105 kN*



* Please observe the installation instructions.

Subject to technical alterations.

No. 6215RP-250

Clamping module, screw-in version

Pneumatic opening.
Opening operating pressure: min. 5 bar - max. 12 bar.
Housing and piston hardened.
Repetition accuracy < 0.1 mm.

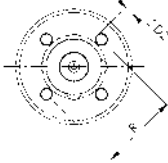
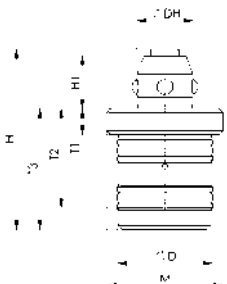

Order no.	Size	Pull-in/locking force up to	Holding force*	Weight
		[N]	[N]	[g]
561989	RP250	100	1000	40

Application:

Pneumatic zero point clamping system for set-up-time-optimised clamping during non-cutting machining.
Ideally suited for applications in the transfer automation range because no interference contour is present underneath the interchangeable pallet.

Note:

The zero-point clamping system is opened (1) pneumatically and locked mechanically by spring force. Subsequent uncoupling of the pressure line is possible at any time (zero-point clamping system is clamped at normal pressure).
The base plate serves as the contact surface, into which the zero-point clamping system is screwed. A suitable mounting tool is available under the order no. 559439.
* Please observe the installation instructions.

On request:

- Installation drawings

Dimensions:

Order no.	Size	dia. D	dia. D2	ØDH	H	H1	M	R	T1	T2	T3
561989	RP250	18	2,2	10,6	34,3	10	M22 x 1	14,75	4,95	19	23

No. 6215RP-251

Clamping module, screw-in version, short design

Pneumatic opening.
Operating pressure for opening: min. 5 bar - max. 12 bar.
Housing and piston hardened.
Repetition accuracy < 0.1 mm.

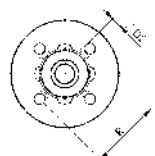
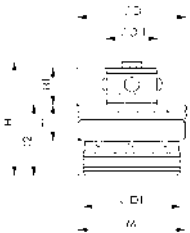

NEW!

Order no.	Size	Pull-in/locking force up to	Holding force*	Weight
		[N]	[N]	[g]
567134	RP251	100	1000	32

Application:

Pneumatic zero point clamping system for set-up-time-optimised clamping during non-cutting machining.
Ideally suited for applications in the transfer automation range because no interference contour is present underneath the interchangeable pallet.

Note:

The zero-point clamping system is opened (1) pneumatically and locked mechanically by spring force. Subsequent uncoupling of the pressure line is possible at any time (zero-point clamping system is clamped at normal pressure). Venting is performed via a connection (5).
The base plate serves as the contact surface, into which the zero-point clamping system is screwed. A suitable mounting tool is available under the order no. 559439.
* Please observe the installation instructions.

On request:

- Installation diagrams

Dimensions:

Order no.	Size	dia. D	dia. D1	dia. D2	ØDH	H	H1	M	R	T1	T2
567134	RP251	22,4	20	2,2	10,6	23,4	7,6	M22 x 1	14,75	7,5	14,5

Subject to technical alterations.

No. 6203SP

Installation clamping module, screw-in version

Pneumatic opening.
Opening operating pressure: min. 6 bar - max. 12 bar.
Cover and piston hardened.
Repeatability < 0.02 mm.

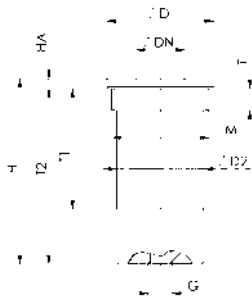

NEW!

Order no.	Size	Pull-in/locking force up to	Holding force*	Weight
		[N]	[N]	[g]
564839	SP140	70	500	12
427286	SP150	235	6000	48

Application:

Zero-point clamping system for set-up-time-optimised clamping during cutting and non-cutting machining.

Note:

The installation clamping module has high holding, pull-in and locking forces. This is opened pneumatically (1) and locked mechanically through spring force. Subsequent uncoupling of the pressure lines is possible at any time (module is clamped pressure-free).

The clamping module has one connection:

1x pneum. Open (1).

For ease of installation, we recommend the size 140 installation tool Order no. 564843 and the size 150 installation tool Order no. 565395.

* Please observe the installation instructions.

On request:

- Installation diagrams

Dimensions:

Order no.	Size	dia. D	dia. DN	dia. D2	G	H	HA	M	T	T1	T2
564839	SP140	15	7	12	M3	20,0	1,00	M13 x 0,5	3,5	-	19,00
427286	SP150	22	10	18	M5	38,5	2,05	M20 x 1,5	4,5	25	36,45

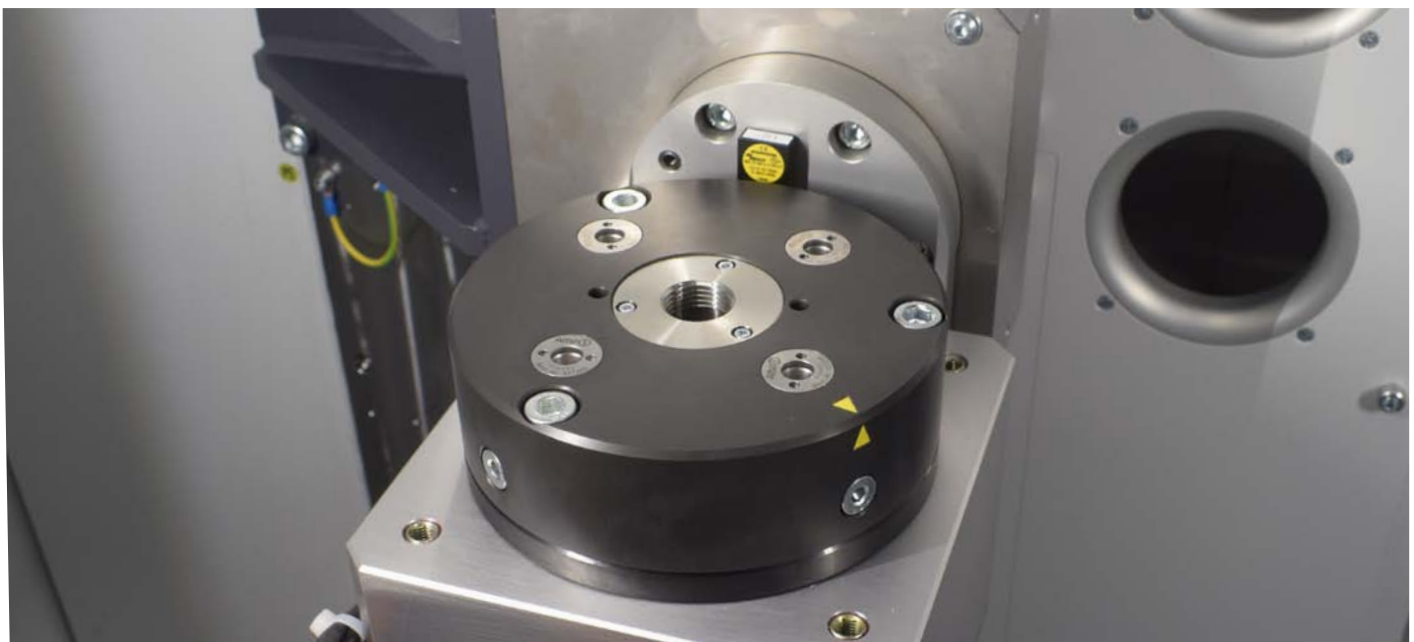

Subject to technical alterations.

No. 6370EARH

Installation clamping module, screw-in version

Hydraulic opening.
Opening operating pressure: min. 50 bar - max. 60 bar.
Cover and piston hardened.
Repeatability < 0.005 mm.

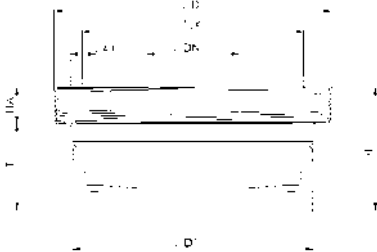
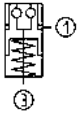

Order no.	Size	Pull-in/locking force up to	Holding force*	Blow out	Weight
		[kN]	[kN]		[g]
305953	KH5	5	13	●	150

Application:

Zero-point clamping system for set-up-time-optimised clamping during cutting and non-cutting machining. With small space requirement and low installation height.

Note:

The installation clamping module has high holding, pull-in and locking forces. This is opened hydraulically (1) and mechanically locked through spring force. Subsequent uncoupling of the pressure lines is possible at all times (module is tensioned pressure-free). The contact surface serves as the upper housing surface. The clamping module with blow-out has two connections: 1x hydr. opening (1), 1x pneum. Blow-out and support control (3). (The pneumatic blow-out and support control can optionally be connected.) The suitable installation tool is available under the AMF order no. 41046.
* Please observe the installation instructions.

On request:

- Installation diagrams

Dimensions:

Order no.	Size	dia. D	dia. DN	dia. D1	H	HA	dia. LK	T
305953	KH5	M45 x 1	15	39	19,8	5,8	36	14

No. 6370EARL

Installation clamping module, screw-in version

Pneumatic opening.
Opening operating pressure: min. 8 bar - max. 12 bar.
Retensioning operating pressure (turbo): min. 5 bar - max. 6 bar.
Cover and piston hardened.
Repeatability < 0.005 mm.

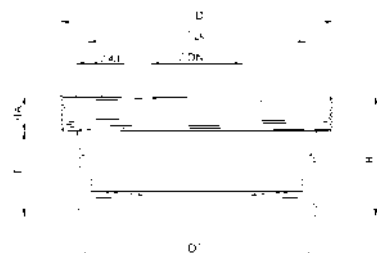
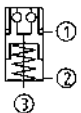

Order no.	Size	Pull-in/locking force up to	Holding force*	Blow out	Weight
		[kN]	[kN]		[g]
563900	KP5	1,5	13	●	150

Application:

Zero-point clamping system for set-up-time-optimised clamping during cutting and non-cutting machining. With small space requirement and low installation height.

Note:

The installation clamping module has high holding, pull-in and locking forces. This is opened pneumatically (1) and locked mechanically through spring force. To achieve the specified pull-in and locking forces, it must be briefly retensioned pneumatically (turbo) (2). Subsequent uncoupling of the pressure lines is possible at any time (module is clamped pressure-free). The contact surface is the upper surface of the housing. It is recommended to use the pneumatic pressure booster no. 6370ZVL. The clamping module with blow-out has three connections: 1x pneum. Opening (1), 1x pneum. Retensioning (turbo) (2), 1x pneum. Blow-out and support control (3). (The pneumatic blow-out and support control can optionally be connected.) The suitable installation tool is available under the AMF order no. 41046.
* Please observe the installation instructions.

On request:

- Installation diagrams

Dimensions:

Order no.	Size	dia. D	dia. DN	dia. D1	H	HA	dia. LK	T
563900	KP5	M45 x 1	15	39	19,8	5,8	36	14



Subject to technical alterations.

No. 6204HA

Installation clamping module

Hydraulic opening.
Pneumatic blow-out.
Opening operating pressure: min. 50 bar - max. 60 bar.
Cover and piston hardened.
Repeatability < 0.005 mm.

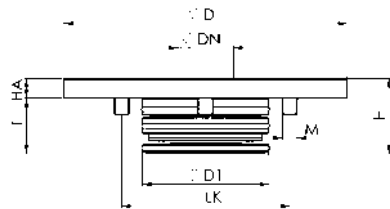
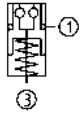

Order no.	Size	Pull-in/locking force up to [kN]	Holding force* [kN]	Blow out	Weight [Kg]
427369	KH10.2	10	25	●	0.6

Application:

Zero-point clamping system for set-up-time-optimised clamping during cutting and non-cutting machining.

Note:

The installation clamping module KH10.2 is opened with the air-hydraulic pump, order no. 426569, with 5 bar pneumatic input pressure.
The clamping module has high holding, pull-in and locking forces. It is opened hydraulically (1) and mechanically locked through spring force. Subsequent uncoupling of the pressure lines is possible at all times (module is tensioned pressure-free).
The clamping module with blow-out and support control has two connections: 1x hydr. opening (1) / 1x pneum. blow-out and support control (3). (The pneumatic blow-out and support control can optionally be connected.)
* Please observe the installation instructions.

On request:

- Installation diagrams

CAD



Dimensions:

Order no.	Size	dia. D	dia. DN	dia. D1	H	HA	dia. LK	M	T
427369	KH10.2	112	22	50	30	8	77	M6	22

No. 6204IHA

Installation clamping module with indexing

Hydraulic opening.
Pneumatic blow-out.
Opening operating pressure: min. 50 bar - max. 60 bar.
Cover and piston hardened.
Repeatability < 0.005 mm.

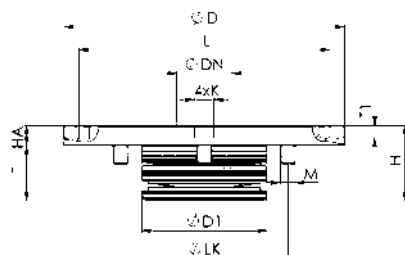
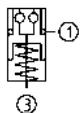

Order no.	Size	Pull-in/locking force up to [kN]	Holding force* [kN]	Blow out	Weight [Kg]
428490	KH10.2	10	25	●	0.6

Application:

Zero-point clamping system for set-up-time-optimised clamping during cutting and non-cutting machining.

The indexing function of the clamping module prevents the pallet from twisting, enabling exact positioning every 90°.

Note:

The installation clamping module KH10.2 with 4-way indexing is opened with the air-hydraulic pump, order no. 426569, with 5 bar pneumatic input pressure.
The clamping module has high holding, pull-in and locking forces. It is opened hydraulically (1) and mechanically locked through spring force. Subsequent uncoupling of the pressure lines is possible at all times (module is tensioned pressure-free).
The clamping module with blow-out and support control has two connections: 1x hydr. opening (1) / 1x pneum. blow-out and support control (3). (The pneumatic blow-out and support control can optionally be connected.)
* Please observe the installation instructions.

On request:

- Installation diagrams

CAD



Dimensions:

Order no.	Size	dia. D	dia. DN	dia. D1	H	HA	K F6	L	dia. LK	M	T	T1
428490	KH10.2	112	22	50	30	8	8	100	77	M6	22	5

Subject to technical alterations.

No. 6370EARHA

Installation clamping module

Hydraulic opening.
Pneumatic blow-out.
Opening operating pressure: min. 50 bar - max. 60 bar.
Cover and piston hardened.
Repeatability < 0.005 mm.



INOX
STAINLESS STEEL

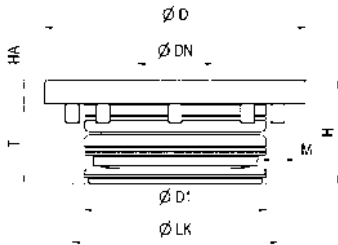
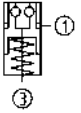

Order no.	Size	Pull-in/locking force up to	Holding force*	Blow out	Weight
		[kN]	[kN]		[Kg]
428680	KH10	10	25	●	0,45
427971	KH20	20	55	●	1,40
429845	KH40	40	105	●	3,40

Application:

Zero-point clamping system for set-up-time-optimised clamping during cutting and non-cutting machining.

Note:

The installation clamping module has high holding, pull-in and locking forces. This is opened hydraulically (1) and mechanically locked through spring force. Subsequent uncoupling of the pressure lines is possible at all times (module is tensioned pressure-free). The clamping module with blow-out and support control has two connections: 1x hydr. opening (1) / 1x pneum. blow-out and support control (3). (The pneumatic blow-out and support control can optionally be connected.)

Installation clamping module in flange version for simplified installation, see 6151HA.

* Please observe the installation instructions.

On request:

- Installation diagrams

CAD



Dimensions:

Order no.	Size	dia. D	dia. DN	dia. D1	H	HA	dia. LK	M	T
428680	KH10	78	22	50	30	7	60	M5	23
427971	KH20	112	32	78	44	10	88	M6	34
429845	KH40	148	40	102	57	15	118	M8	42

No. 6370EARLA

Installation clamping module

Pneumatic opening.
Pneumatic blow-out.
Opening operating pressure: min. 8 bar - max. 12 bar.
Retensioning operating pressure (turbo): min. 5 bar - max. 6 bar.
Cover and piston hardened.
Repeatability < 0.005 mm.



INOX
STAINLESS STEEL

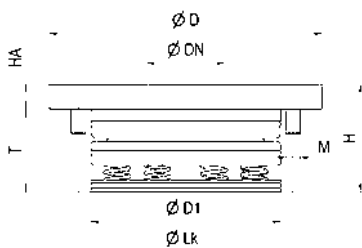
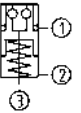

Order no.	Size	Pull-in/locking force up to	Holding force*	Blow out	Weight
		[kN]	[kN]		[Kg]
305375	KP10	8	25	●	0,45
303016	KP20	17	55	●	1,40
303057	KP40	30	105	●	3,40

Application:

Zero-point clamping system for set-up-time-optimised clamping during cutting and non-cutting machining.

Note:

The installation clamping module has high holding, pull-in and locking forces. This is opened pneumatically (1) and locked mechanically through spring force. To achieve the specified pull-in and locking forces, it must be briefly retensioned pneumatically (turbo) (2). Subsequent uncoupling of the pressure lines is possible at any time (module is clamped pressure-free). Use of the pneumatic pressure booster no. 6370ZVL is recommended.

The clamping module with blow-out and support control has three connections: 1x pneum. Opening (1) / 1x pneum. Retensioning (turbo) (2), 1x pneum. Blow-out and support control (3). (The pneumatic blow-out and support control can optionally be connected.)

* Please observe the installation instructions.

On request:

- Installation diagrams

CAD



Dimensions:

Order no.	Size	dia. D	dia. DN	dia. D1	H	HA	dia. LK	M	T
305375	KP10	78	22	50	30	7	60	M5	23
303016	KP20	112	32	78	44	10	88	M6	34
303057	KP40	148	40	102	57	15	118	M8	42

Subject to technical alterations.

No. 6370EAIHA

Installation clamping module with indexing

Hydraulic opening.
Pneumatic blow-out.
Opening operating pressure: min. 50 bar - max. 60 bar.
Cover and piston hardened.
Repeatability < 0.005 mm.

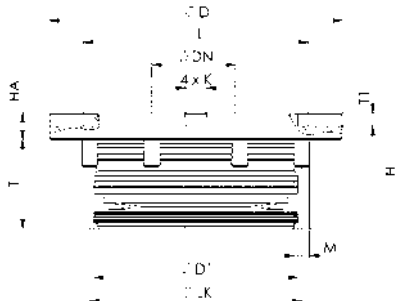
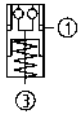

Order no.	Size	Pull-in/locking force up to	Holding force*	Blow out	Weight [Kg]
		[kN]	[kN]		
428425	KH20	20	55	●	1,4

Application:

Zero-point clamping system for set-up-time-optimised clamping during cutting and non-cutting machining.
The indexing function of the clamping module prevents the pallet from twisting, enabling exact positioning every 90°.

Note:

The installation clamping module has high holding, pull-in and locking forces. This is opened hydraulically (1) and mechanically locked through spring force. Subsequent uncoupling of the pressure lines is possible at all times (module is tensioned pressure-free).
The clamping module with blow-out and support control has two connections: 1x hydr. opening (1) / 1x pneum. blow-out and support control (3). (The pneumatic blow-out and support control can optionally be connected.)

* Please observe the installation instructions.

On request:

- Installation diagrams

CAD



Dimensions:

Order no.	Size	dia. D	dia. DN	dia. D1	H	HA	K F6	L	dia. LK	M	T	T1
428425	KH20	112	32	78	44	10	8	86	88	M6	34	5

No. 6370EAILA

Installation clamping module with indexing

Pneumatic opening.
Pneumatic blow-out.
Opening operating pressure: min. 8 bar - max. 12 bar.
Retensioning operating pressure (turbo): min. 5 bar - max. 6 bar.
Cover and piston hardened.
Repeatability < 0.005 mm.

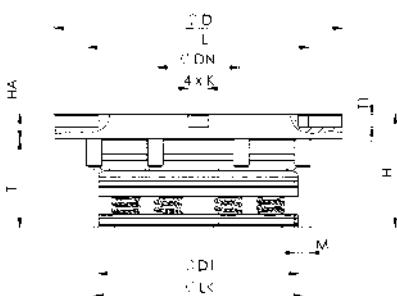
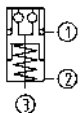

Order no.	Size	Pull-in/locking force up to	Holding force*	Blow out	Weight [Kg]
		[kN]	[kN]		
428441	KP20	17	55	●	1,4

Application:

Zero-point clamping system for set-up-time-optimised clamping during cutting and non-cutting machining.
The indexing function of the clamping module prevents the pallet from twisting, enabling exact positioning every 90°.

Note:

The installation clamping module has high holding, pull-in and locking forces. This is opened pneumatically (1) and mechanically locked through spring force. To achieve the specified pull-in and locking forces, it must be briefly retensioned pneumatically (turbo) (2). Subsequent uncoupling of the pressure lines is possible at all times (module is tensioned pressure-free). Use of the pneumatic pressure booster 6370ZVL is recommended.

The clamping module with blow-out and support control has three connections: 1x pneum. opening (1) / 1x pneum. retensioning (turbo) (2), 1x pneum. blow-out and support control (3). (The pneumatic blow-out and support control can optionally be connected.)

* Please observe the installation instructions.

On request:

- Installation diagrams

CAD



Dimensions:

Order no.	Size	dia. D	dia. DN	dia. D1	H	HA	K F6	L	dia. LK	M	T	T1
428441	KP20	112	32	78	44	10	8	86	88	M6	34	5

Subject to technical alterations.

No. 6217EARHA20

Installation clamping module

Hydraulic opening.
 Pneumatic blow-out.
 Opening operating pressure: min. 60 - max. 70 bar
 Cover and piston hardened.
 Repetition accuracy < 0.005 mm.

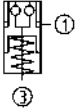

Order no.	Size	Pull-in/locking force up to	Holding force*	Blow out	Weight
		[kN]	[kN]		
561990	KH20.4	30	55	●	1,7

Design:

Zero-point clamping system with increased pull-in/locking force and centric blow-out.

Application:

Zero-point clamping system for set-up-time-optimised clamping during cutting and non-cutting machining.

Note:

The installation clamping module has high holding, pull-in and locking forces. This is opened hydraulically (1) and mechanically locked through spring force. Subsequent uncoupling of the pressure lines is possible at any time (module is clamped pressure-free).

The clamping module with blow-out and support control has two connections: 1x hydr. opening (1), 1x pneum. Blow-out and support control (3). (The pneumatic blow-out and support control can optionally be connected.)

* Please observe the installation instructions.

On request:

- Installation drawings

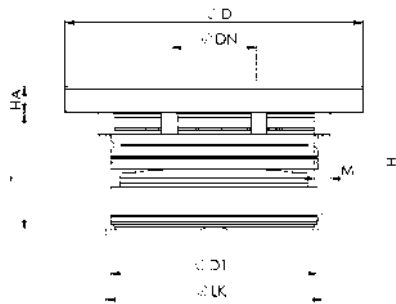

Dimensions:

Order no.	Size	dia. D	dia. DN	dia. D1	H	HA	dia. LK	M	T
561990	KH20.4	112	32	78	54	10	88	M6	44





No. 6206LA

Installation clamping module

Pneumatic opening.
 Pneumatic blow-out.
 Opening operating pressure:
 KP5.3 min. 5 bar - max. 12 bar.
 KP10.3 min. 5 bar - max. 12 bar.
 KP20.3 min. 4.5 bar - max. 12 bar.
 Cover and piston hardened.
 Repeat accuracy < 0.005 mm.

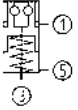

**ZERO-POINT CLAMPING
FROM 4.5 BAR**

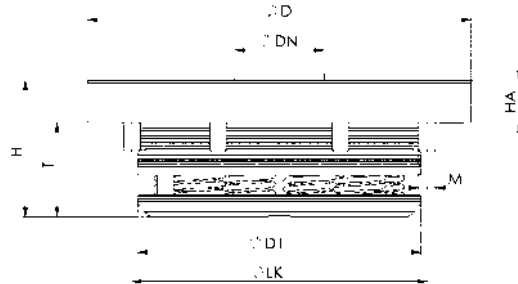

Order no.	Size	Pull-in/locking force up to	Holding force*	Blow out	Weight
		[kN]	[kN]		[Kg]
553152	KP5.3	1,5	13	●	0,5
428730	KP10.3	10,0	25	●	1,4
428755	KP20.3	17,0	55	●	2,6

Application:

Zero-point clamping system for set-up-time-optimised clamping during cutting and non-cutting machining.

Note:

The installation clamping module has high holding, pull-in and locking forces. This is opened pneumatically (1) and mechanically locked through spring force. Subsequent uncoupling of the pressure lines is possible at all times (module is tensioned pressure-free).
 The clamping module with blow-out and support control has two connections:
 1x pneum. opening (1), 1x pneum. blow-out and support control (3). (The pneumatic blow-out and support control can optionally be connected.)
 * Please observe the installation instructions.

On request:

- Installation diagrams

Dimensions:

Order no.	Size	dia. D	dia. DN	dia. D1	H	HA	dia. LK	M	T
553152	KP5.3	78	15	54,5	29	8	62	M4	21
428730	KP10.3	112	22	78,0	35	10	88	M6	25
428755	KP20.3	138	32	102,0	49	15	115	M6	34



No. 6206ILA

Installation clamping module with indexing

Pneumatic opening.
Pneumatic blow-out.

Opening operating pressure:

KP10.3 min. 5 bar - max. 12 bar.

KP20.3 min. 4.5 bar - max. 12 bar.

Retensioning operating pressure > min. 5 bar / max. 6 bar.

Cover and piston hardened.

Repetition accuracy < 0.005 mm.

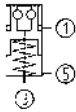

KP10.3

KP20.3

Order no.	Size	Pull-in/locking force up to [kN]	Holding force* [kN]	Blow out	Weight [Kg]
428771	KP10.3	10	25	●	1,4
428797	KP20.3	17	55	●	2,6

Application:

Zero-point clamping system for set-up-time-optimised clamping during cutting and non-cutting machining.

The indexing function of the clamping module prevents the pallet from twisting, enabling exact positioning every 90°.

Note:

The installation clamping module has high holding, pull-in and locking forces. This is opened pneumatically (1) and mechanically locked through spring force. Subsequent uncoupling of the pressure lines is possible at all times (module is tensioned pressure-free).

The clamping module with blow-out and support control has two connections:

1x opening (1), 1x pneum. blow-out and support control (3). (The pneumatic blow-out and support control can optionally be connected.)

* Please observe the installation instructions.

On request:

- Installation diagrams

**ZERO-POINT CLAMPING
FROM 4.5 BAR**

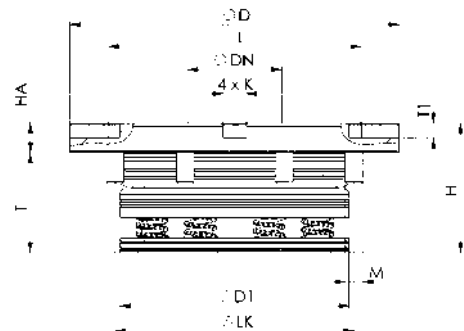

Dimensions:

Order no.	Size	dia. D	dia. DN	dia. D1	H	HA	K F6	L	dia. LK	M	T	T1
428771	KP10.3	112	22	78	35	10	8	100	88	M6	25	5
428797	KP20.3	138	32	102	49	15	10	108	115	M6	34	5





SIMPLIFIED INSTALLATION IN THE BODY - THE INSTALLATION CLAMPING MODULE AS FLANGE VERSION

The flange version of the installation clamping module has a centring ring on the underside. This allows simplified and precisely positioned installation of the module in the body. Through the low depth of the required mounting hole for the centring ring, existing fixtures and be easily and inexpensively refitted with the AMF Zero-Point System. The clamping module can be operated from the outside via a tube connection or from the bottom via an O-ring connection.



Subject to technical alterations.

No. 6151HA

Installation clamping module, flange version

Hydraulic opening.
Pneumatic blow-out.
Opening operating pressure: min. 50 bar - max. 60 bar.
Cover and piston hardened.
Repeatability < 0.005 mm.

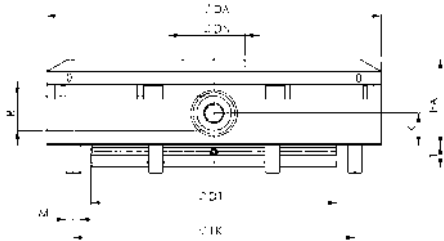
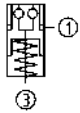

Order no.	Size	Pull-in/locking force up to	Holding force*	Blow out	Weight [Kg]
		[kN]	[kN]		
424085	KH10	10	25	●	1,35
423962	KH20	20	55	●	3,75
424143	KH40	40	105	●	4,97

Application:

Zero-point clamping system for set-up-time-optimised clamping during cutting and non-cutting machining.

Note:

The flange version permits a simplified installation in the body. This is exactly positioned via the centring function. The clamping module can be operated from the outside via a tube connection or from the bottom via an O-ring connection.

This is opened hydraulically (1) and mechanically locked through spring force. Subsequent uncoupling of the pressure lines is possible at all times (module is tensioned pressure-free).

The clamping module with blow-out and support control has two connections:

1x hydr. opening (1) / 1x pneum. blow-out and support control (3). (The pneumatic blow-out and support control can optionally be connected.)

* Please observe the installation instructions.

CAD



Dimensions:

Order no.	Size	dia. DA	dia. DN	dia. D1	HA	K	dia. LK	M	R	T
424085	KH10	100	22	67	24	9	90	M5	G1/8	5,9
423962	KH20	136	32	100	35	13	124	M6	G1/8	8,9
424143	KH40	180	40	125	45	15	163	M8	G1/4	11,9

No. 6151L

Installation clamping module, flange version

Pneumatic opening.
Opening operating pressure: min. 8 bar - max. 12 bar.
Retensioning operating pressure (turbo): min. 5 bar - max. 6 bar.
Cover and piston hardened.
Repeatability < 0.005 mm.

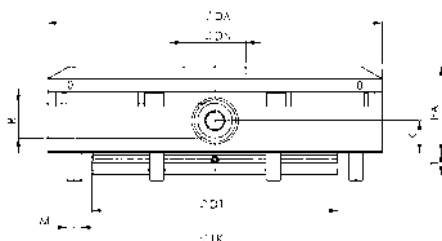

Order no.	Size	Pull-in/locking force up to	Holding force*	Weight [Kg]
		[kN]	[kN]	
424101	KP10	8	25	1,35
423988	KP20	17	55	3,75
424168	KP40	30	105	4,97

Application:

Zero-point clamping system for set-up-time-optimised clamping during cutting and non-cutting machining.

Note:

The flange version permits a simplified installation in the body. This is exactly positioned via the centring function. This is opened pneumatically (1) and mechanically locked through spring force.

To achieve the specified pull-in and locking forces, this must be briefly retensioned pneumatically (turbo) (2). Subsequent uncoupling of the pressure lines is possible at all times (module is tensioned pressure-free).

Use of the pneumatic pressure booster 6370ZVL is recommended.

The clamping module has two connections:

1x pneum. opening (1) / 1x pneum. retensioning (turbo) (2).

* Please observe the installation instructions.

CAD



Dimensions:

Order no.	Size	dia. DA	dia. DN	dia. D1	HA	K	dia. LK	M	R	T
424101	KP10	100	22	67	24	9	90	M5	G1/8	5,9
423988	KP20	136	32	100	35	13	124	M6	G1/8	8,9
424168	KP40	180	40	125	45	15	163	M8	G1/4	11,9

Subject to technical alterations.

No. 6370HARH

Horizontal rapid-clamping cylinder

Hydraulic opening.
Opening operating pressure: min. 50 bar - max. 60 bar.
Cover and piston hardened.
Repeatability < 0.005 mm.

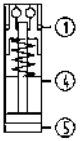
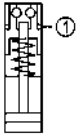

Order no.	Size	Pull-in/locking force up to [kN]	Holding force* [kN]	Advance motion, hydr. suspension piston	max. weight per suspension piston [kN]	Weight [Kg]
303065	KH20	20	55	-	5	2,1
306217	KH20	20	55	●	5	2,1
303107	KH40	40	105	-	8	5,2
306258	KH40	40	105	●	8	5,2

Design:

As standard, there is a manual (hand power) or hydraulic run-out and run-in movements of the suspension piston.

- Cylinder has one connection: 1x hydr. opening (1),
- Cylinder with hydraulic advance motion has three connections: 1x hydr. opening (1), Run out 1x hydr. suspension piston opening (5), run in 1x hydr. suspension piston opening (4).

Application:

Zero-point clamping system for set-up-time-optimised clamping during cutting and non-cutting machining. For installation in clamping profiles, cubes and towers. The horizontal toggle clamp cylinder is used to change fixtures quickly and easily by means of the suspension piston with hand force, hydraulic or handling device.

Note:

The horizontal rapid-clamping cylinder has high holding, pull-in and locking forces. This is opened hydraulically (1) and mechanically locked through spring force. Subsequent uncoupling of the pressure lines is possible at all times (module is tensioned pressure-free). The maximum weight per suspension piston must not exceed 5 kN at KH20 and 8 kN at KH40.

* Please observe the installation instructions.

On request:

- Installation diagrams

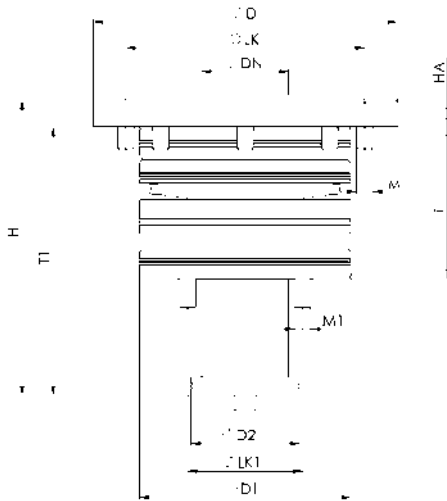

Dimensions:

Order no.	Size	dia. D	dia. DN	dia. D1	dia. D2	H	HA	dia. LK	dia. LK1	M	M1	T	T1
303065	KH20	112	32	78	40	109	10	88	60	M6	M6	56,5	99
306217	KH20	112	32	78	40	109	10	88	60	M6	M6	56,5	99
303107	KH40	148	40	102	48	144	15	118	76	M8	M8	73,0	129
306258	KH40	148	40	102	48	144	15	118	76	M8	M8	73,0	129

No. 6370ZMSH

Mounting key for horizontal rapid-clamping cylinder

Suitable for 6370HARH.



Order no.	Size	Weight [g]
424556	20	520
426866	40	940

Application:

The mounting key is needed for installation of the threaded sleeve of the horizontal rapid-clamping cylinder.

HORIZONTAL RAPID-CLAMPING CYLINDER

This is how to make vertical palletization quick and uncomplicated:

- > No searching for the holes
- > No hydraulic or pneumatic pre-tensioning
- > No damage from zero-point hole and pull-stud
- > No risk of injury
- > Reduced set-up times and thus cost savings

Flexibly usable in clamping towers, clamping brackets, automated handling devices or in general machine building.



> Whether by hand, with crane, handling device or robot: Horizontal rapid-clamping cylinders offer maximum protection and comfort.



> After the pallet has been mounted, it can easily be pushed in and out. This process can be automated, if desired.

No. 6370KARH

Compact cylinder

Hydraulic opening.
 Opening operating pressure: min. 50 bar - max. 60 bar.
 Cover and piston hardened.
 Repeatability < 0.005 mm.

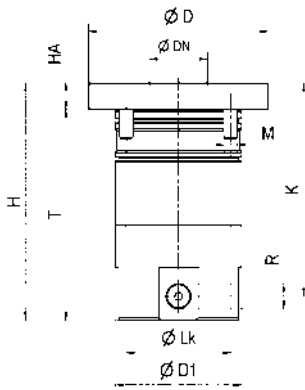

Order no.	Size	Pull-in/locking force up to	Holding force*	Weight
		[kN]	[kN]	[Kg]
303503	KH10	1,3	25	2,5

Application:

For retrofitting to modular profiles, columns, tombstones and cubes. Can be used with thin wall sections.

Note:

There are six standard connection options. Four connections are located on the side of the lateral surface at 90° intervals. Seals on the external diameter make it possible to connect a deep-hole drill bore in the base plate. Connection is also possible on the floor surface of the compact cylinder.
 * Please observe the installation instructions.

On request:

- Installation diagrams

Dimensions:

Order no.	Size	dia. D	dia. DN	dia. D1	H	HA	K	dia. LK	M	R	T
303503	KH10	68	22	48	90	10	81	4x56	M6	G1/8	80

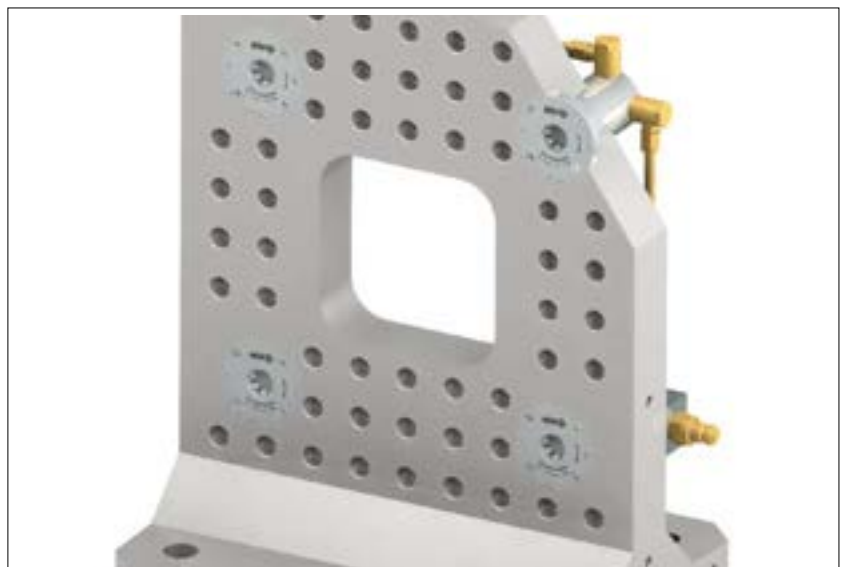

Subject to technical alterations.



SURFACE-MOUNTED CLAMPING MODULES

The AMF surface-mounted clamping modules are installed on pallets, machine tables, clamping brackets and cubes. Usable when cutting, grinding, eroding and on plastic-processing machines as well as for fixture construction with mounting fixtures and handling systems.

The AMF clamping modules can be installed in all positions. Whether vertical or overhead - mounting works completely without assembly tools.

Surface-mounted clamping modules are available in four different sizes:

- > **Clamping modules KH5 / KP5** - dia. 62 mm - pull-in/locking force up to 5 kN - holding force 13 kN*
- > **Clamping modules KH10 / KP10** - dia. 78 mm - pull-in/locking force up to 10 kN - holding force 25 kN*
- > **Clamping modules KH20 / KP20** - dia. 112 mm - pull-in/locking force up to 20 kN - holding force 55 kN*
- > **Clamping modules KH40 / KP40** - dia. 148 mm - pull-in/locking force up to 40 kN - holding force 105 kN*



* Please observe the installation instructions.

Subject to technical alterations.

No. 6370AARH

Surface-mounted clamping module

Hydraulic opening.
Opening operating pressure: min. 50 bar - max. 60 bar.
Cover and piston hardened.
Repeatability < 0.005 mm.

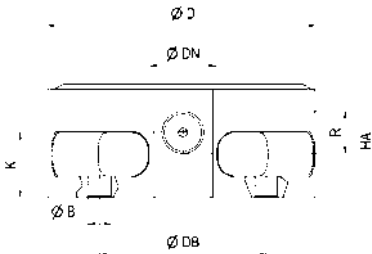

Order no.	Size	Pull-in/locking force up to	Holding force*	Weight
		[kN]	[kN]	[g]
306159	KH5	5	13	300

Application:

Zero-point clamping system for set-up-time-optimised clamping during cutting and non-cutting machining.

Note:

The surface-mounted clamping module has high holding, pull-in and locking forces. This is opened hydraulically (1) and mechanically locked through spring force. Subsequent uncoupling of the pressure lines is possible at all times (module is tensioned pressure-free). The contact surface is the upper surface of the housing. The clamping module has one connection: 1x hydr. opening (1).
* Please observe the installation instructions.

On request:

- Individual housing



Dimensions:

Order no.	Size	dia. B	dia. D	dia. DB	dia. DN	HA	K	R
306159	KH5	5,8	62	54	15	26	15	G1/8

No. 6370AARL

Surface-mounted clamping module

Pneumatic opening.
Opening operating pressure: min. 8 bar - max. 12 bar.
Retensioning operating pressure (turbo): min. 5 bar - max. 6 bar.
Cover and piston hardened.
Repeatability < 0.005 mm.

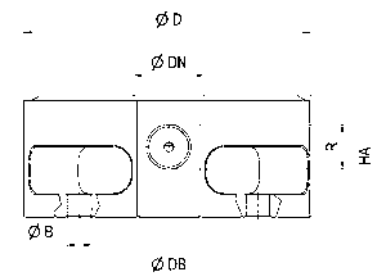

Order no.	Size	Pull-in/locking force up to	Holding force*	Weight
		[kN]	[kN]	[g]
306175	KP5	1,5	13	300

Application:

Zero-point clamping system for set-up-time-optimised clamping during cutting and non-cutting machining.

Note:

The surface-mounted clamping module has high holding, pull-in and locking forces. This is opened pneumatically (1) and mechanically locked through spring force. To achieve the specified pull-in and locking forces, it must be briefly retensioned pneumatically (turbo) (2). Subsequent uncoupling of the pressure lines is possible at all times (module is tensioned pressure-free). The contact surface is the upper surface of the housing. Use of the pneumatic pressure booster 6370ZVL is recommended. The clamping module has two connections: 1x pneum. opening (1) / 1x pneum. retensioning (turbo) (2).
* Please observe the installation instructions.

On request:

- Individual housing



Dimensions:

Order no.	Size	dia. B	dia. D	dia. DB	dia. DN	HA	K	R
306175	KP5	5,8	62	54	15	26	15	G1/8

Subject to technical alterations.

No. 6370AARHA

Surface-mounted clamping module

Hydraulic opening.
Pneumatic blow-out.
Opening operating pressure: min. 50 bar - max. 60 bar.
Cover and piston hardened.
Repeatability < 0.005 mm.

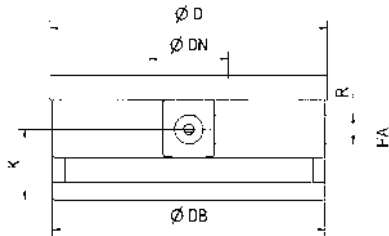
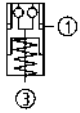

Order no.	Size	Pull-in/locking force up to	Holding force*	Blow out	Weight
		[kN]	[kN]		[Kg]
303545	KH10	10	25	●	0,9
302836	KH20	20	55	●	2,7
302877	KH40	40	105	●	6,6

Application:

Zero-point clamping system in combination with hook clamping flange 63707B for set-up-time-optimised clamping during cutting and non-cutting machining.

Note:

The surface-mounted clamping module has high holding, pull-in and locking forces. This is opened hydraulically (1) and mechanically locked through spring force. Subsequent uncoupling of the pressure lines is possible at all times (module is tensioned pressure-free).

The clamping module with blow-out and support control has two connections: 1x hydr. opening (1) / 1x pneum. blow-out and support control (3). (The pneumatic blow-out and support control can optionally be connected.)

* Please observe the installation instructions.

On request:

- Individual housing

CAD



Dimensions:

Order no.	Size	dia. D	dia. DB	dia. DN	HA	K	R
303545	KH10	78	77,5	22	32	16,50	G1/8
302836	KH20	112	110,0	32	50	28,25	G1/4
302877	KH40	148	146,0	40	62	32,50	G1/4

No. 6370AARLA

Surface-mounted clamping module

Pneumatic opening.
Pneumatic blow-out.
Opening operating pressure: min. 8 bar - max. 12 bar.
Retensioning operating pressure (turbo): min. 5 bar - max. 6 bar.
Cover and piston hardened.
Repeatability < 0.005 mm.

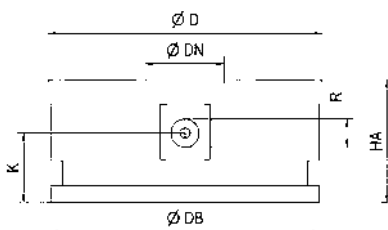
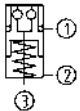

Order no.	Size	Pull-in/locking force up to	Holding force*	Blow out	Weight
		[kN]	[kN]		[Kg]
305193	KP10	8	25	●	0,9
302851	KP20	17	55	●	2,6
302893	KP40	30	105	●	6,6

Application:

Zero-point clamping system in combination with hook clamping flange 63707B for set-up-time-optimised clamping during cutting and non-cutting machining.

Note:

The surface-mounted clamping module has high holding, pull-in and locking forces. This is opened pneumatically (1) and mechanically locked through spring force. To achieve the specified pull-in and locking forces, it must be briefly retensioned pneumatically (turbo) (2). Subsequent uncoupling of the pressure lines is possible at all times (module is tensioned pressure-free).

Use of the pneumatic pressure booster 6370ZVL is recommended.

The clamping module with blow-out and support control has three connections:

1x pneum. opening (1) / 1x pneum. retensioning (turbo) (2), 1x pneum. blow-out and support control (3). (The pneumatic blow-out and support control can optionally be connected.)

* Please observe the installation instructions.

On request:

- Individual housing

CAD



Dimensions:

Order no.	Size	dia. D	dia. DB	dia. DN	HA	K	R
305193	KP10	78	77,5	22	32	16,50	G1/8
302851	KP20	112	110,0	32	50	28,25	G1/4
302893	KP40	148	146,0	40	62	32,50	G1/4

No. 6370ZB

Clamping flange, Set

Consisting of two single-clamp buckles, nitrided.

Order no.	Size	Set contents [St]	dia. D	dia. DB	H	dia. LK	M	Weight [g]
426825	10	2	114	77,5	7,75	94	8,5	360
426833	20	2	164	110,0	13,00	136	11,0	800
426841	40	2	202	146,0	16,00	172	13,0	1100

Application:

Clamping flanges are used to fasten surface-mounted clamping modules on the machine table.

On request:

- Special clamping flanges for various T-slot tables
- Clamping flange and housing manufactured as a single piece

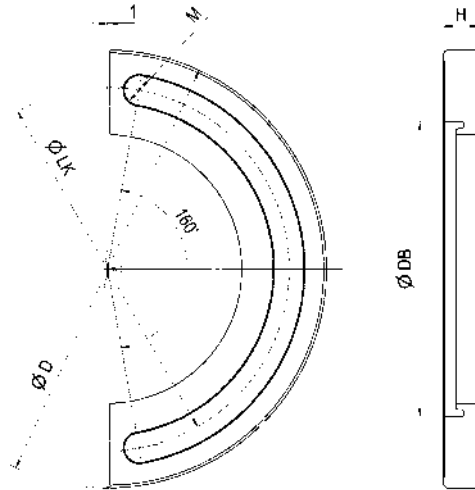

Examples of machine-table mounting:

K10 - Groove distance 50 mm

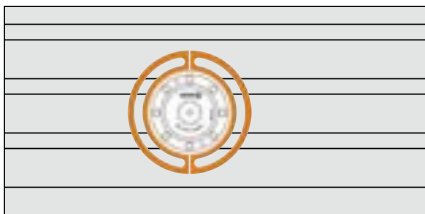

Groove distance 63 mm

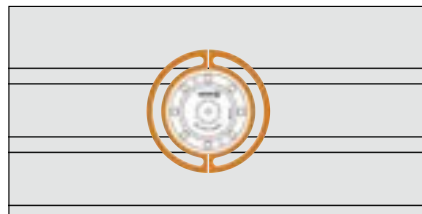

Groove distance 80 mm

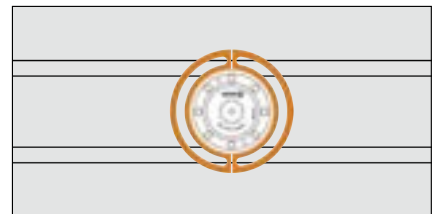

K20 - Groove distance 50 mm

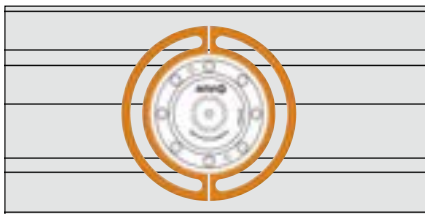

Groove distance 63 mm

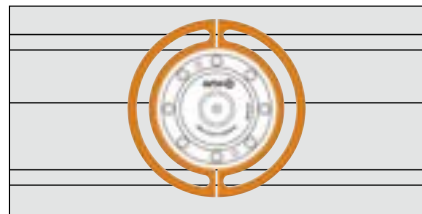

Groove distance 80 mm

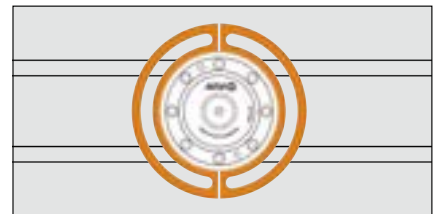

K40 - Groove distance 50 mm

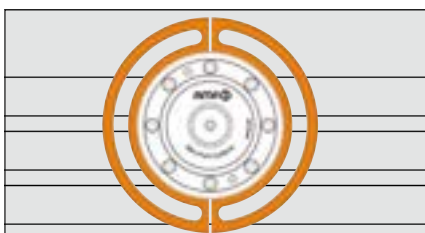

Groove distance 63 mm

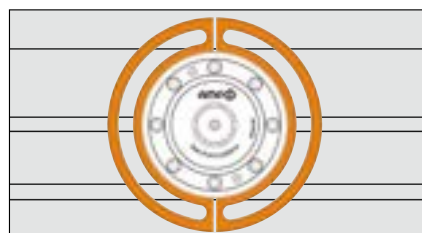

Groove distance 80 mm

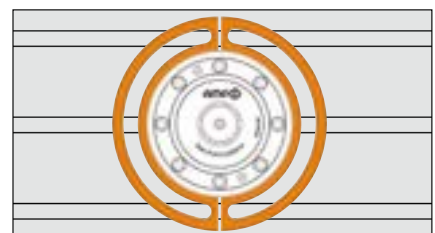

Subject to technical alterations.



ZERO-POINT SYSTEMS FROM AMF - THE UNIFORM INTERFACE IN ADDITIVE MANUFACTURING



- + Designed for the special requirements of additive manufacturing
- + A uniform interface in 3D printing and post-processing
- + Drastic reduction of your set-up times
- + Integrated blow-out of the clamping modules

PLEASE ASK US!

Subject to technical alterations.

AUTOMATION SOLUTIONS FROM AMF

The enormous capability and flexibility of use of modern processing machines is undisputed. To be able to use these capabilities in reality requires more than just fast machines. An automation solution consists today of a number of multiply linked, versatile products and technologies.

Through the possibility of a fully automatic and process-sure machine configuration, our automation solutions meet the requirements for seamless integration into the automation system. Numerous sensing options, optional media ducts and blow-out and blow-off of the modules speak for themselves!

Persuade yourself of the automation potential of the AMF zero-point clamping modules!

1. OPENING CONTROL



IS THE MODULE OPEN?

Through the direct monitoring of the piston position (opened) by means of pneumatic back pressure, the position can be sensed by means of a differential pressure switch.

5. LOCKING CONTROL

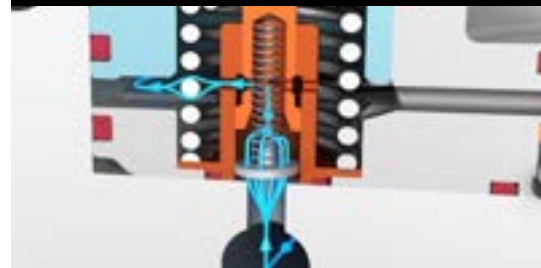

IS THE MODULE LOCKED?

With an open module, the integrated stop valve creates a pneumatic static pressure, which is sensed via a differential pressure switch.

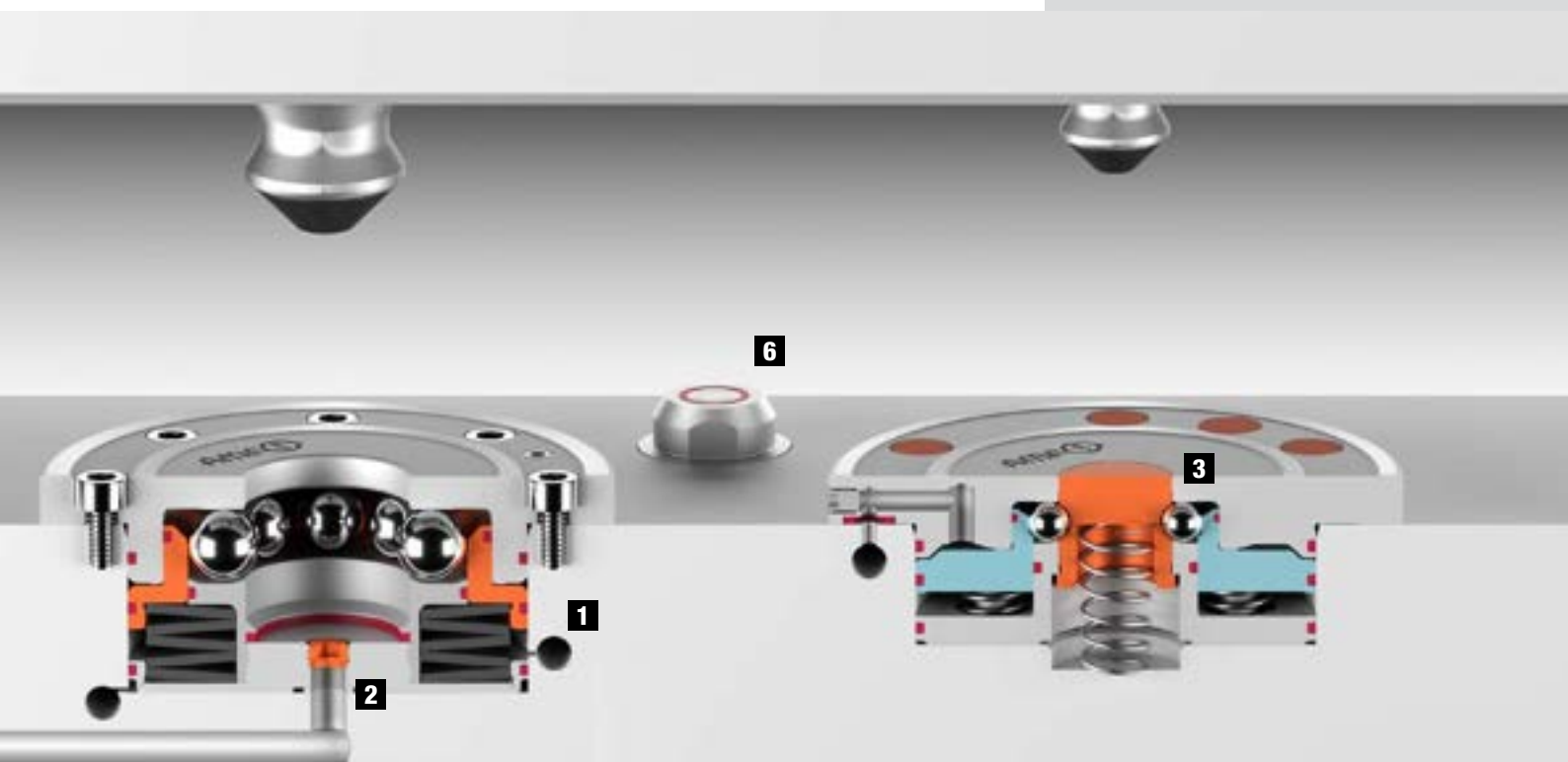

2. INTERNAL BLOW-OUT



DIRT AND CHIPS IN THE CLAMPING MODULE?

Blowing out with compressed air cleans the inside from all dirt and chips and can be used simultaneously for workpiece support control by means of a differential pressure sensor.

3. CENTRAL LOCK

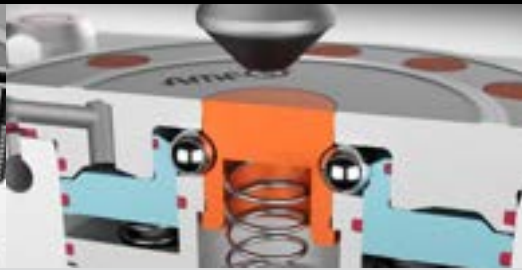

DIRT AND CHIPS UNWELCOME IN THE MODULE?

The lagging central lock prevents penetration of dirt and chips when the pull-stud is being run out. The central lock replaces the previously required protection pull-stud.

4. STUD SENSING



IS THE PULL-STUD PRESENT ON THE FIXTURE?

The retracting stud actuates a stop valve, which eliminates the pneumatic or hydraulic static pressure. This condition is sensed via a differential pressure switch.

6. MEDIA DUCTS



ARE MEDIA DUCTS TO A FIXTURE NECESSARY?

Oil, compressed air, water, etc. can be run through our couplings without leaks.

7. BLOW-OFF/SUPPORT CONTROL



CHIPS AND DIRT? IS A WORKPIECE LYING WITHOUT GAP OR NOT?

The blow-out function with compressed air cleans the support surfaces and can be used simultaneously for workpiece support control by means of a differential pressure sensor.

8. ELECTRICAL SENSING



IS THE MODULE OPEN OR CLOSED?

The integrated inductive sensor can sense the piston position (open/closed) of the clamping module.

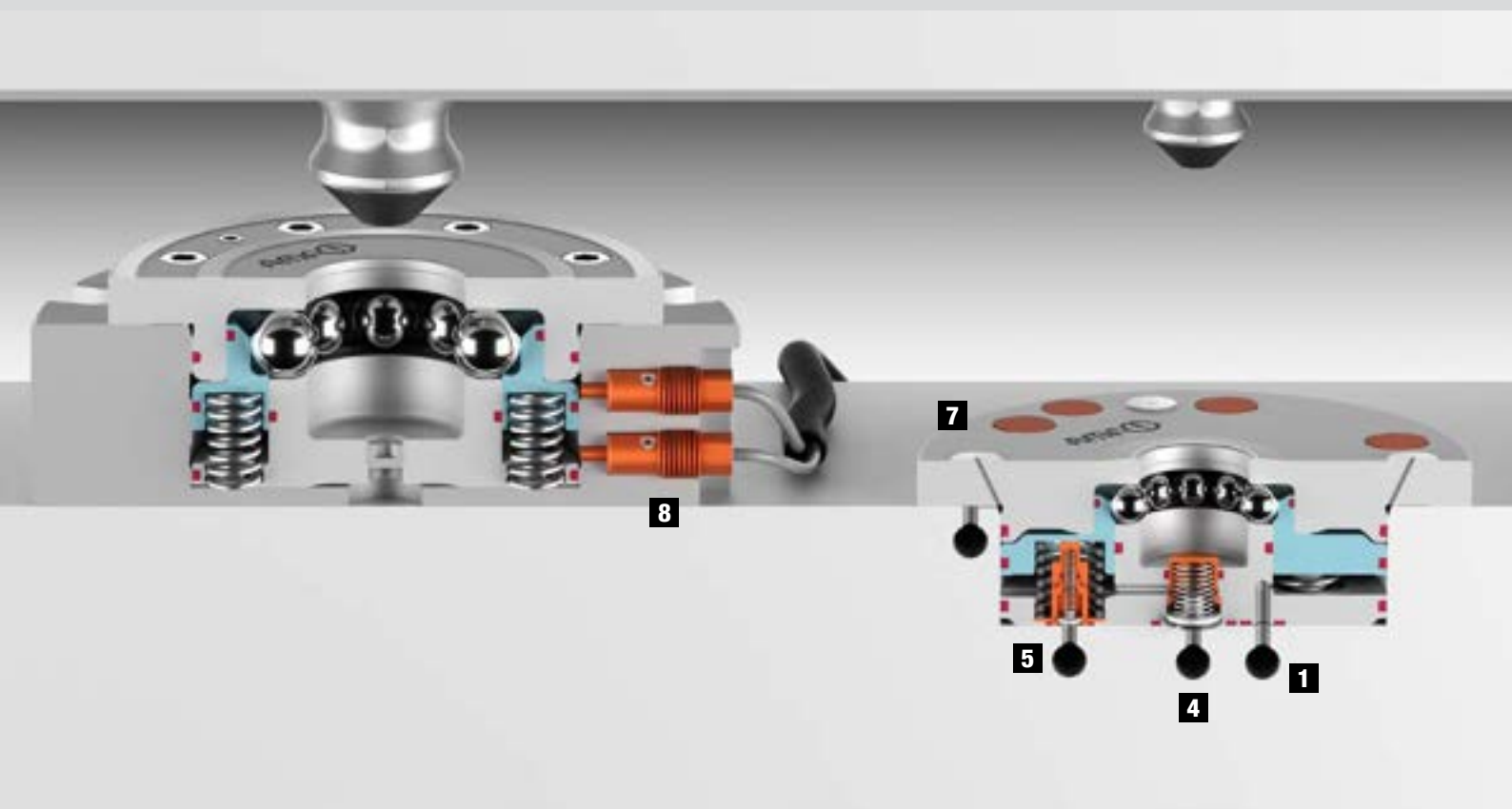

Subject to technical alterations.

OUR AUTOMATION SOLUTIONS - THE RIGHT CLAMPING MODULE FOR EVERY APPLICATION

	SP150	KP5	KP5.3	KP10	KP10.3	KP10.3	KP10.3	KP10.3	KP10.3	KP10.3
	Order no. 559089	Order no. 561992	Order no. 558051	Order no. 552963	Order no. 559390	Order no. 552967	Order no. 559391	Order no. 550257	Order no. 550259	Order no. 550261
	pneum.	pneum.	pneum.	pneum.	pneum.	pneum.	pneum.	pneum.	pneum.	pneum.
Support diameter max. [mm]	22	45	78	78	112	112	112	112	112	-
Raised supports with discharge and support control										●
Pull-in/locking force in the system up to [kN]	235 N	1,5	1,5	8	10	10	10	10	10	10
Holding force* [kN]	6	13	13	25	25	25	25	25	25	25
Operating pressure for pneum. opening min. - max. [bar]	6 - 14	8 - 12	5 - 12	8 - 12	5 - 12	5 - 12	5 - 12	5 - 12	5 - 12	5 - 12
Operating pressure for pneum. re-clamping min. - max. [bar]		5 - 6		5 - 6						
Operating pressure for hydr. opening min. - max. [bar]										
Pneum. blow-out		●			●		●	●	●	●
Pneum. support control		●			●		●	●	●	●
Pneum. locking control		●					●	●	●	●
Opening control pneum.		●					●	●	●	●
Hydr. locking control										
Opening control hydr.									●	●
Pneum. pull-stud sensing										
Sensor monitor opened	●		●	●		●				
Sensor monitor closed	●		●	●		●				
Central lock					●		●			
Central lock with pneum. blow-out										

* Please observe the installation instructions.

KH20 Order no. 428409	KH20 Order no. 427161	KH20 Order no. 550279	KP20 Order no. 552964	KP20.3 Order no. 552968	KP20.3 Order no. 550258	KP20.3 Order no. 550260	KP20.3 Order no. 550262	KP40 Order no. 552965	
hydr.	hydr.	hydr.	pneum.	pneum.	pneum.	pneum.	pneum.	pneum.	
112	-	112	112	138	138	138	-	148	Support diameter max. [mm]
	●						●		Raised supports with discharge and support control
20	20	20	17	17	17	17	17	30	Pull-in/locking force in the system up to [kN]
55	55	55	55	55	55	55	55	105	Holding force* [kN]
			8 - 12	4,5 - 12,0	4,5 - 12,0	4,5 - 12,0	4,5 - 12,0	8 - 12	Operating pressure for pneum. opening min. - max. [bar]
			5 - 6					5 - 6	Operating pressure for pneum. re-clamping min. - max. [bar]
60 - 70	50 - 60	60 - 70							Operating pressure for hydr. opening min. - max. [bar]
●		●			●	●	●		Pneum. blow-out
●	●	●			●	●	●		Pneum. support control
					●	●	●		Pneum. locking control
●	●	●			●	●	●		Opening control pneum.
	●								Hydr. locking control
	●					●	●		Opening control hydr.
	●								Pneum. pull-stud sensing
			●	●				●	Sensor monitor opened
			●	●				●	Sensor monitor closed
									Central lock
		●							Central lock with pneum. blow-out

* Please observe the installation instructions.

Subject to technical alterations.

No. 6103LA-5

Installation clamping module for automation solutions, screw-in version

Pneumatic opening.
Pneumatic blow-out.

Opening operating pressure: min. 8 bar - max. 12 bar.
Retensioning operating pressure (turbo): min. 5 - max. 6 bar
Cover and piston hardened.
Repetition accuracy < 0,005 mm.
With locking control (pneum.), opening control (pneum.) and support control (pneum.).

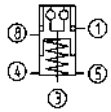

Order no.	Size	Pull-in/locking force up to	Holding force*	Blow out	Weight
		[kN]	[kN]		
561992	KP5	1,5	13	●	175

Design:

Centric blow-out, support control, opening and locking control.

Application:

Zero-point clamping system for automation solutions for set-up-time-optimised clamping during cutting and non-cutting machining.

Note:

Locking control: Dynamic pressure with locked clamping module, flow-through with opened clamping module.

Opening control: Dynamic pressure with opened clamping module, flow-through with locked clamping module.

The installation clamping module is opened pneumatically and locked mechanically by spring force. To achieve the specified pull-in and locking forces, it must be briefly retensioned pneumatically (turbo) (5).

Subsequent uncoupling of the pressure line is possible at any time (module is clamped at normal pressure).

The contact surface is the upper surface of the housing. It is recommended to use a pneumatic pressure booster no. 6370ZVL. Matching mounting tool is available under the AMF order no. 41046.

The clamping module has five connections:

- 1 = pneum. Opening
- 3 = pneum. Blow-out
- 4 = pneum. Opening control inlet
- 5 = pneum. Retensioning and venting
- 8 = pneum. Inlet locking control

* Please observe the installation instructions.

On request:

- Installation drawings

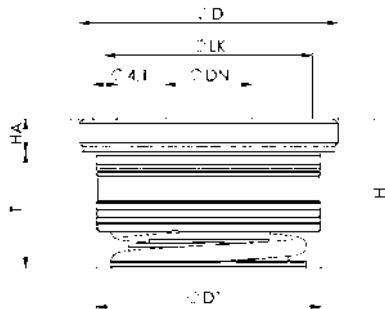

Dimensions:

Order no.	Size	dia. D	dia. DN	dia. D1	H	HA	dia. LK	T
561992	KP5	M45 x 1	15	39	25,8	5,8	36	20



No. 6108LA-XX-08

Installation clamping module for automation solutions

Pneumatic opening.
 Pneumatic blow-out.
 Operating pressure for opening:
 KP5.3 min. 5 bar - max. 12 bar.
 KP10.3 min. 5 bar - max. 12 bar.
 KP20.3 min. 4.5 bar - max. 12 bar.
 Cover and piston hardened.
 Repetition accuracy < 0.005 mm.
 With locking control (pneum.), opening control (pneum.) and support control (pneum.).

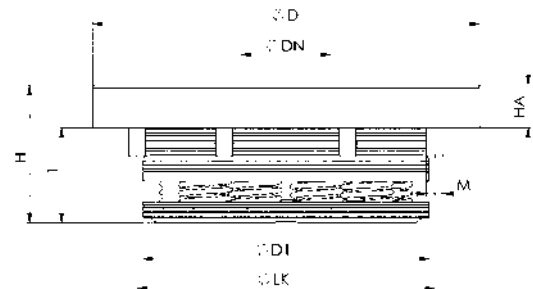
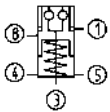

NEW!

Order no.	Size	Pull-in/locking force up to [kN]	Holding force* [kN]	Blow out	Weight [Kg]
561991	KP5.3	1,5	13	●	0,5
550257	KP10.3	10	25	●	1,4
550258	KP20.3	17	55	●	2,6

Design:

Centric blow-out, support control and opening and locking control.

Application:

Zero-point clamping system for automation solutions for set-up-time-optimised clamping during cutting and non-cutting machining.

Note:

Locking control: Dynamic pressure with locked clamping module, flow-through with opened clamping module.

Opening control: Dynamic pressure with opened clamping module, flow-through with locked clamping module. Support control via the blow-out function: Dynamic pressure with supported interchangeable pallet.

The installation clamping module is opened pneumatically and locked mechanically by spring force. Subsequent uncoupling of the pressure line is possible at any time (module is clamped at normal pressure).

The clamping module has five connections:

- 1 = pneum. Opening
- 3 = pneum. Blow-out
- 4 = pneum. Opening control inlet
- 5 = venting
- 8 = pneum. Locking control inlet

* Please observe the installation instructions.

On request:

- Installation diagrams

Dimensions:

Order no.	Size	dia. D	dia. DN	dia. D1	H	HA	dia. LK	M	T
561991	KP5.3	78	15	54,5	29	8	62	M4	21
550257	KP10.3	112	22	78,0	35	10	88	M6	25
550258	KP20.3	138	32	102,0	49	15	115	M6	34



No. 6108LA-XX-09

Installation clamping module for automation solutions

Pneumatic opening.
Pneumatic blow-out.

Operating pressure for opening:
KP10.3 min. 5 bar - max. 12 bar.
KP20.3 min. 4.5 bar - max. 12 bar.

Cover and piston hardened.

Repetition accuracy < 0.005 mm.

With locking control (pneum.), opening control (pneum.), support control (pneum.) and pull-stud sensing (pneum.).

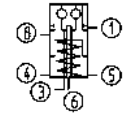

Order no.	Size	Pull-in/locking force up to	Holding force*	Blow out	Weight
		[kN]	[kN]		
550259	KP10.3	10	25	●	1,4
550260	KP20.3	17	55	●	2,6

Design:

Centric blow-out, support control and opening and locking control and pull-stud sensing.

Application:

Zero-point clamping system for automation solutions for set-up-time-optimised clamping during cutting and non-cutting machining.

Note:

Locking control: Dynamic pressure with locked clamping module, flow-through with opened clamping module.

Opening control: Dynamic pressure with opened clamping module, flow-through with locked clamping module.

Pull-stud sensing: Dynamic pressure with pull-stud present, flow-through if pull-stud is not present.

Support control via the blow-out function: Dynamic pressure with supported interchangeable pallet.

The installation clamping module is opened pneumatically and locked mechanically by spring force.

Subsequent uncoupling of the pressure line is possible at any time (module is clamped at normal pressure).

The clamping module has six connections:

- 1 = pneum. opening
- 3 = pneum. blow-out
- 4 = pneum. opening control inlet
- 5 = vent
- 6 = pneum. pull-stud control, inlet
- 8 = pneum. locking control, inlet

* Please observe the installation instructions.

On request:

- Installation diagrams



KP10.3

KP20.3

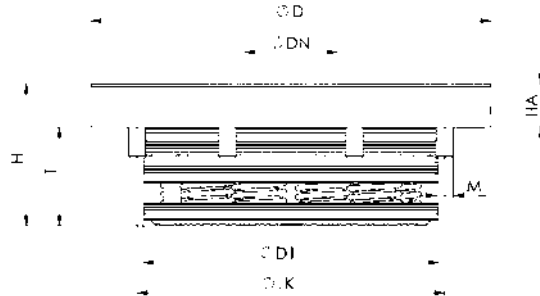

Dimensions:

Order no.	Size	dia. D	dia. DN	dia. D1	H	HA	dia. LK	M	T
550259	KP10.3	112	22	78	35	10	88	M6	25
550260	KP20.3	138	32	102	49	15	115	M6	34



Subject to technical alterations.

No. 6108LA-XX-10

Installation clamping module for automation solutions

Pneumatic opening.

Pneumatic blow-out.

Operating pressure for opening:

KP10.3 min. 5 bar - max. 12 bar.

KP20.3 min. 4.5 bar - max. 12 bar.

Cover and piston hardened.

Repetition accuracy < 0.005 mm.

With locking control (pneum.), opening control (pneum.), support control (pneum.) and pull-stud sensing (pneum.) and insular support.

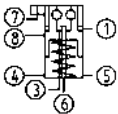

Order no.	Size	Pull-in/locking force up to [kN]	Holding force* [kN]	Blow out	Weight [Kg]
550261	KP10.3	10	25	●	1,4
550262	KP20.3	17	55	●	2,6

Design:

Contact surfaces as isolated design with integrated blow-out, centric blow-out, support control, locking control and pull-stud sensing.

Application:

Zero-point clamping system for automation solutions for set-up-time-optimised clamping during cutting and non-cutting machining.

Note:

Locking control: Dynamic pressure with locked clamping module, flow-through with opened clamping module.

Opening control: Dynamic pressure with opened clamping module, flow-through with locked clamping module.

Pull-stud sensing: Dynamic pressure with pull-stud present, flow-through if pull-stud is not present.

Support control: Dynamic pressure with supported interchangeable pallet.

The installation clamping module is opened pneumatically and locked mechanically by spring force. Subsequent uncoupling of the pressure line is possible at any time (module is clamped at normal pressure).

The clamping module has seven connections:

- 1 = pneum. opening
- 3 = pneum. blow-out
- 4 = pneum. opening control inlet
- 5 = vent
- 6 = pneum. pull-stud control, inlet
- 7 = pneum. support control
- 8 = pneum. locking control, inlet

* Please observe the installation instructions.

On request:

- Installation diagrams

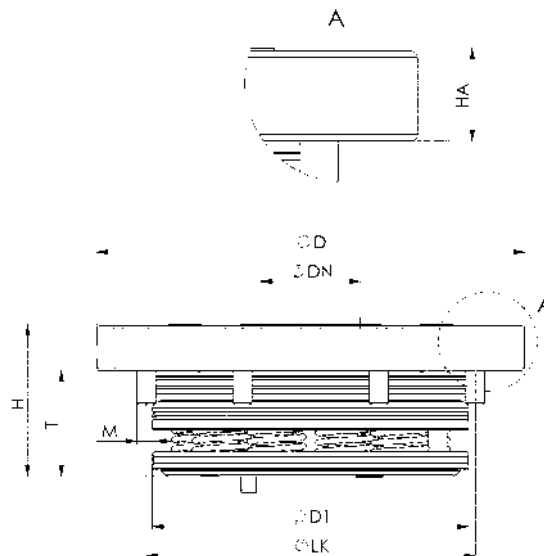

Dimensions:

Order no.	Size	dia. D	dia. DN	dia. D1	H	HA	dia. LK	M	T
550261	KP10.3	112	22	78	35	10	88	M6	25
550262	KP20.3	138	32	102	49	15	115	M6	34



No. 6111LA-10-01

Installation clamping module with central lock for automation solutions

Pneumatic opening.
 Pneumatic blow-out.
 Opening operating pressure: min. 5 bar - max. 12 bar.
 Cover and piston hardened.
 Repetition accuracy < 0.005 mm.

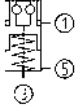

Order no.	Size	Pull-in/locking force up to [kN]	Holding force* [kN]	Blow out	Weight [Kg]
559390	KP10.3	10	25	●	1,4

Application:

Zero-point clamping system for automation solutions for set-up-time-optimised clamping during cutting and non-cutting machining.

Note:

The central lock actuated by spring force for protection of the clamping module. The pull-stud is fastened and installed using an M8 DIN ISO countersunk head screw. Support control via the blow-out function: Dynamic pressure with supported interchangeable pallet. The clamping module is opened pneumatically and locked mechanically by spring force. Subsequent disconnection of the pressure line is possible at any time (clamping module is clamped without pressure).

The clamping module has three connections:

- 1 = pneum. Opening
- 3 = pneum. Blow-out
- 5 = venting

* Please observe the installation instructions.

On request:

- Installation diagrams

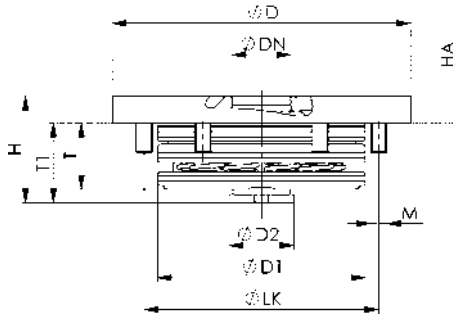

Dimensions:

Order no.	Size	dia. D	dia. DN	dia. D1	dia. D2	H	HA	dia. LK	M	T	T1
559390	KP10.3	112	22	78	25	40	10	88	M6	25	30



No. 6111LA-10-05

Installation clamping module with central lock for automation solutions

Pneumatic opening.
 Pneumatic blow-out.
 Opening operating pressure: min. 5 bar - max. 12 bar.
 Cover and piston hardened.
 Repetition accuracy < 0.005 mm.
 With locking control (pneum.), opening control (pneum.) and support control (pneum.).

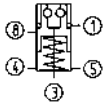

Order no.	Size	Pull-in/locking force up to [kN]	Holding force* [kN]	Blow out	Weight [Kg]
559391	KP10.3	10	25	●	1,4

Application:

Zero-point clamping system for automation solutions for set-up-time-optimised clamping during cutting and non-cutting machining.

Note:

The central lock actuated by spring force for protection of the clamping module. The pull-stud is fastened and installed with a DIN ISO countersunk head screw M8.
 Locking control: Dynamic pressure with locked clamping module, flow-through with opened clamping module.
 Opening control: Dynamic pressure with opened clamping module, flow-through with locked clamping module. Support control via the blow-out function: Dynamic pressure with supported interchangeable pallet. The clamping module is opened pneumatically and locked mechanically by spring force. Subsequent uncoupling of the pressure line is possible at any time (clamping module is clamped at normal pressure).

The clamping module has five connections:

- 1 = pneum. opening
- 3 = pneum. blow-out
- 4 = pneum. opening control inlet
- 5 = vent
- 8 = pneum. locking control, inlet

* Please observe the installation instructions.

On request:

- Installation diagrams

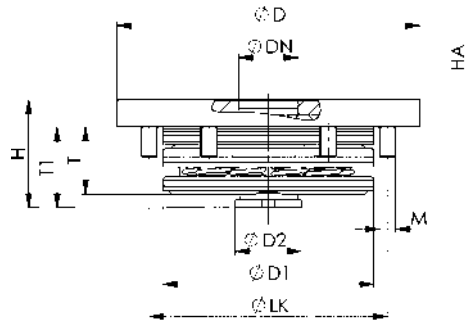

Dimensions:

Order no.	Size	dia. D	dia. DN	dia. D1	dia. D2	H	HA	dia. LK	M	T	T1
559391	KP10.3	112	22	78	25	40	10	88	M6	25	30



No. 6103HA-20-05

Installation clamping module for automation solutions

Hydraulic opening.
 Pneumatic blow-out.
 Opening operating pressure: min. 60 bar - max. 70 bar.
 Cover and piston hardened.
 Repetition accuracy < 0.005 mm.
 With opening control (pneum.) and support control (pneum.).

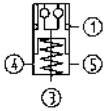

Order no.	Size	Pull-in/locking force up to	Holding force*	Blow out	Weight
		[kN]	[kN]		
428409	KH20	20	55	●	1,4

Design:

Centric blow-out, support control and opening control.

Application:

Zero-point clamping system for automation solutions for set-up-time-optimised clamping during cutting and non-cutting machining.

Note:

Opening control: Dynamic pressure with opened clamping module, flow-through with locked clamping module.

Support control via the blow-out function: Dynamic pressure with supported interchangeable pallet. The installation clamping module is opened hydraulically (1) and mechanically locked through spring force. Subsequent uncoupling of the pressure lines is possible at any time (module is clamped pressure-free).

The clamping module has four connections:

- 1 = hydr. opening
- 3 = pneum. Blow-out and support control
- 4 = pneum. Opening control inlet
- 5 = pneum. Opening control outlet

* Please observe the installation instructions.

On request:

- Installation diagrams

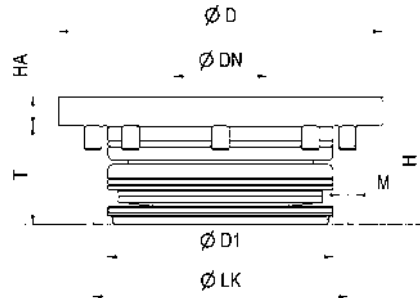

Dimensions:

Order no.	Size	dia. D	dia. DN	dia. D1	H	HA	M	dia. LK	T
428409	KH20	112	32	78	44	10	M6	88	34



No. 6107HA-20-07

Installation clamping module with central lock for automation solutions

Hydraulic opening.
 Pneumatic blow-out.
 Operating pressure: 60 bar - 70 bar.
 Cover and piston hardened.
 Repetition accuracy < 0.005 mm.
 With opening control (pneum.) and support control (pneum.).

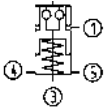

Order no.	Size	Pull-in/locking force up to [kN]	Holding force* [kN]	Blow out	Weight [Kg]
550279	KH20	20	55	●	1,4

Design:

With central lock, blow-out, support control and opening control.

Application:

Zero-point clamping system for automation solutions for set-up-time-optimised clamping during cutting and non-cutting machining.

Note:

Central lock with pneum. cleaning function of support surfaces.
 Fastening and installation of the pull-stud by means of DIN ISO countersunk head screw M12.
 Opening control: Dynamic pressure with opened clamping module, flow-through with locked clamping module.
 Support control via the blow-out function: Dynamic pressure with supported interchangeable pallet.
 The installation clamping module is opened hydraulically and mechanically locked through spring force. Subsequent uncoupling of the pressure line is possible at any time (module is clamped at normal pressure).

The clamping module has four connections:

- 1 = hydr. opening
- 3 = pneum. Blow-out and support control
- 4 = pneum. Opening control inlet
- 5 = pneum. Opening control outlet

* Please observe the installation instructions.

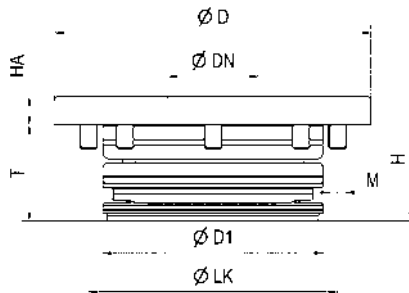

Dimensions:

Order no.	Size	dia. D	dia. DN	dia. D1	H	HA	dia. LK	M	T
550279	KH20	112	32	78	44	10	88	M6	34



No. 6370ZSA-02

Pneumatic sensor unit, Control and sensor module

Operating pressure 4-7 bar.

Order no.	A	B	dia. B1	C	E	H	H1	K	L	M	N	P	dia. Q	S	Weight [g]
553182	95	20,5	5,5	75	68,5	83	78,5	18	115,5	M12 x 1	10,2	17,4	6	50	510

Design:

Pneumatic sensor unit with a control module, preassembled sensor module with integrated LCD display for displaying the operating status and two connecting cables each 5 meters in length and one open end.

Technical data per sensor module:
 Distance measuring range: 0.02 - 0.2 mm
 Pneumatic connection: Q6 Plug connection 6 mm
 Electrical output: 2 switch outputs PNP
 Electrical connection: M12 plug, A-coded

Application:

Pneumatic sensor unit for querying and condition monitoring of the AMF zero-point clamping system for the automation. The switchpoints of the sensor modules are applied directly in the teach-in process and can then be finely adjusted and adapted manually to the individual requirements.

Note:

A maximum of four sensor modules can be mounted and connected per control module.
 Observe the maximum line length.

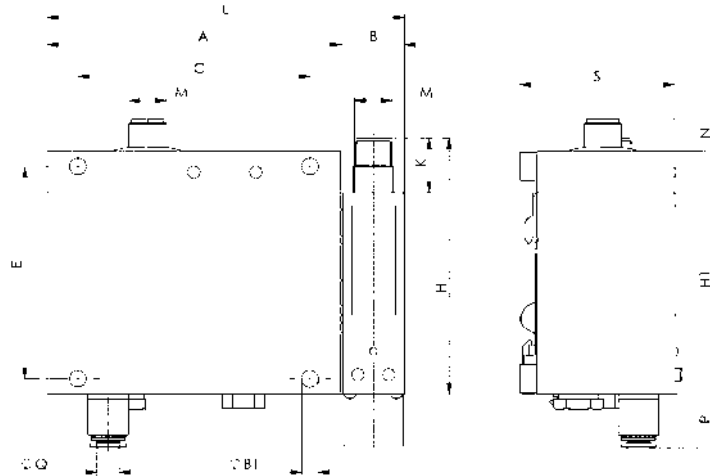

CAD

Subject to technical alterations.

No. 6370ZSA-03

Sensor module for pneumatic sensor unit

Operating pressure 4-7 bar.



Order no.	B	H	K	M	dia. Q	S	Weight [g]
553183	20,5	83	18	M12 x 1	6	50	60

Design:

Sensor module as extension module for the pneumatic sensor unit with integrated LCD display for displaying the operating status and one connecting cable with 5 meters in length and one open end.

Technical data:

Distance measuring range: 0.02 - 0.2 mm

Pneumatic connection: Q6 Plug connection 6 mm

Electrical output: 2 switch outputs PNP

Electrical connection: M12 plug, A-coded

Application:

Sensor module for querying and condition monitoring of the AMF zero-point clamping system for the automation. The switchpoints of the sensor modules are applied directly in the teach-in process and can then be finely adjusted and adapted manually to the individual requirements.

Note:

A maximum of four sensor modules can be mounted and connected per control module.

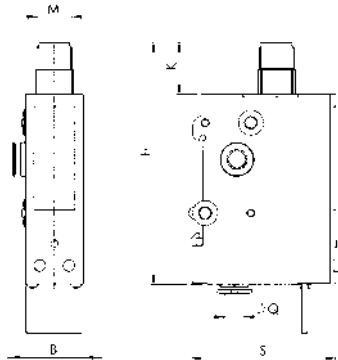

No. 6370ZSA-01

Flow meter

Hydraulic.



Order no.	A	B	C	G	H	H1	K1	M	Nominal bore [NW]	Weight [g]	Q [l/min]
553154	55	55	41	M6	128	90	15,5	M12 x 1	8	700	0,02-2

Design:

Flow meter for hydraulic volume flow of 0.02 - 2.0 l/min incl. 5-metre connecting cable.

Technical data:

Nominal diameter: DN008

Connection: Internal thread G1/4

Compressive strength: PN 200

Measurement range: 0.02 - 2.0 l/min

Medium temperature: - 25 .. + 80 °C

Ambient temperature: - 20 .. + 70 °C

Programming: via adjusting ring POM

Electrical connection: Round plug M12 x 1.5-polig

Power supply: 18 .. 30 V DC

Protection class: IP 67

Hysteresis: adjustable

Display: LCD Display + LED

Application:

Through the very exact measurement resolution of this unit, it is possible to check and monitor whether the zero-point clamping system is in an opened or closed state.

The gearwheel flow meter measures the hydraulic flow in the connection lines of the AMF zero-point clamping system for automation and emits an output signal when the preset threshold value is reached.

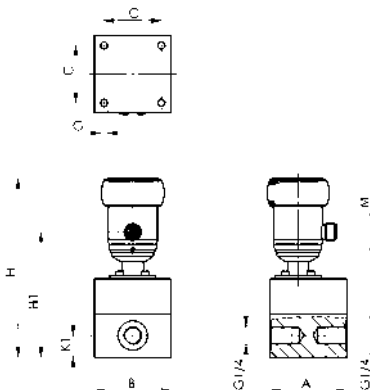

No. 6109SP-150

Installation clamping module with sensor query for opening and interlock

Pneumatic opening.
 Opening operating pressure: min. 6 bar - max. 14 bar.
 Cover and piston hardened.
 Case: Aluminium.
 Repetition accuracy < 0.02 mm.

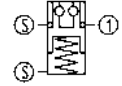

Order no.	Size	Pull-in/locking force up to	Holding force*	Weight
		[N]	[N]	[g]
559089	SP150	235	6000	51

Application:

Zero-point clamping system for automation solutions for set-up-time-optimised clamping during cutting and non-cutting machining.

Note:

The installation clamping module has high holding, pull-in and locking forces. This is opened pneumatically (1) and locked mechanically through spring force. Subsequent uncoupling of the pressure lines is possible at any time (module is clamped pressure-free).

The clamping module has one connection:

1 = pneum. opening

The installation clamping module with sensor query contains the fastening kit order no. 559403. It has two reed sensors with connection cables (Ø 0.75 mm, cable length 100 mm) for status check opened / locked and a fastening clamp.

For simple installation of the installation clamping module, we recommend the AMF pin wrench, order no. 50914.

* Please observe the installation instructions.

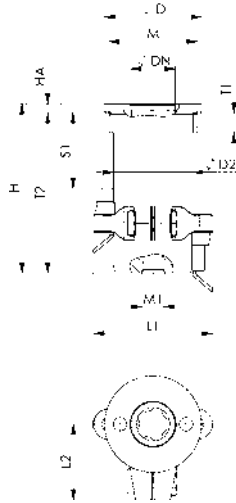

Dimensions:

Order no.	Size	dia. D	dia. DN	dia. D2	H	HA	L1	L2	M	M1	S1	T1	T2
559089	SP150	22	10	18	38,5	2,05	27	17,2	M20x1,5	M5	17	4,5	36,45

No. 6109ZB-150

Fastening kit with sensors

Suitable for installation clamping module SP150 with sensor query.

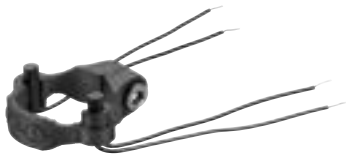

Order no.	Size	dia. D	H	L1	L2	Weight [g]
559403	150	18	16	27	17,2	4

Note:

The fastening kit contains two reed sensors with connection cables (Ø 0.75 mm, cable length 100 mm) for status check opened / locked and a fastening clamp. This kit can be fastened to the clamping module SP150 with sensor query.

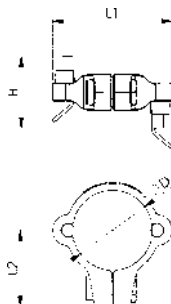

No. 6104L

Clamping module with sensor query for opening and interlock

Pneumatic opening.
 Operating pressure for opening:
 KP5.3 min. 5 bar - max. 12 bar.
 KP10.3 min. 5 bar - max. 12 bar.
 KP12.3 min. 4.5 bar - max. 12 bar.
 Cover and piston hardened.
 Flange housing: aluminium.
 Repetition accuracy < 0.005 mm.

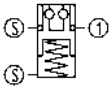

Order no.	Size	Pull-in/locking force up to	Holding force*	Weight
		[kN]	[kN]	[Kg]
558051	KP5.3	1,5	13	1,2
552967	KP10.3	10	25	2,6
552968	KP20.3	17	55	5,0

Application:

Zero-point clamping system for automation solutions for set-up-time-optimised clamping during cutting and non-cutting machining.

Note:

The clamping module with sensor query has two inductive sensors (connection type: plug S8, cable length 150 mm) for the status check (opened / locked). This is opened pneumatically (1) and locked mechanically through spring force. Subsequent uncoupling of the pressure line is possible at any time (module is clamped at normal pressure).

The clamping module has one connection:
 1 = pneum. opening

* Please observe the installation instructions.

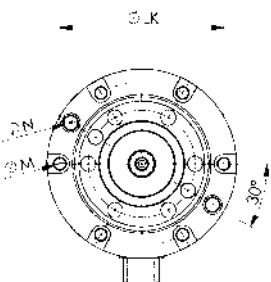
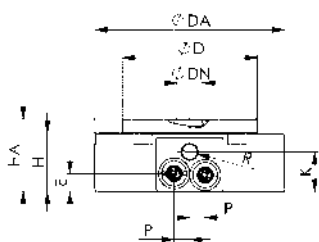

KP5.3

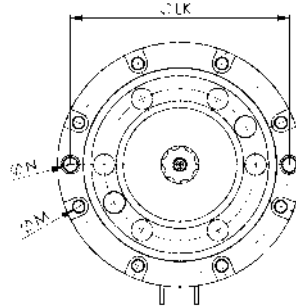
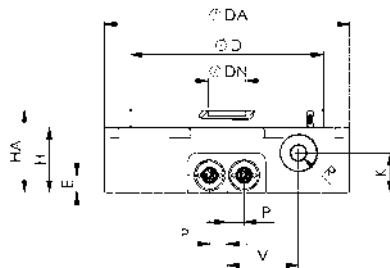

KP10.3

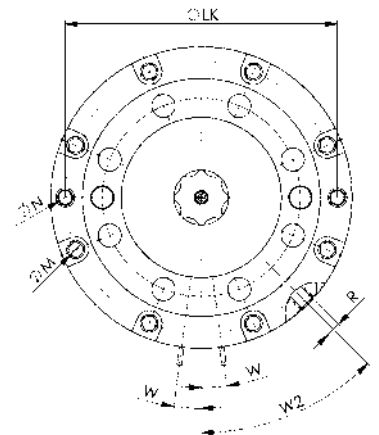
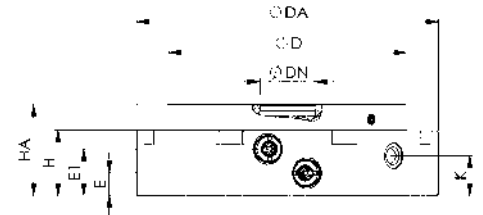

KP20.3

Dimensions:

Order no.	Size	dia. D	dia. DA	dia. DN	E	E1	H	HA	K	dia. LK	dia. M	dia. N H7	P	R	V	W	W2
558051	KP5.3	78	110	15	10,5	-	34	42	23	95	6,6	8	9	G1/8	-	-	-
552967	KP10.3	112	142	22	10	-	38	48	23	127	6,6	8	10	G1/8	41,5	-	-
552968	KP20.3	138	175	32	13	27	38	53	23	158	8,4	8	-	G1/8	-	7,5°	45°



No. 6101L

Clamping module with sensor query for opening and interlock

Pneumatic opening.
 Opening operating pressure: min. 8 bar - max. 12 bar.
 Re-clamping operating pressure (turbo): min. 5 bar - max. 6 bar.
 Cover and piston hardened.
 Flange housing: Stainless steel
 Repetition accuracy < 0.005 mm.

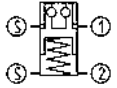

Order no.	Size	Pull-in/locking force up to	Holding force*	Weight
		[kN]	[kN]	[Kg]
552963	KP10	8	25	2,4
552964	KP20	17	55	6,9
552965	KP40	30	105	11,0

Application:

Zero-point clamping system for automation solutions for set-up-time-optimised clamping during cutting and non-cutting machining.

Note:

The installation clamping module with sensor query contains 2 inductive sensors (connection type: S8 plug, cable length: 150 mm) for status check (opened / locked). This is pneumatically opened (1) and mechanically locked through spring force. To achieve the specified pull-in and locking forces, it must be briefly retensioned pneumatically (turbo) (2). Subsequent uncoupling of the pressure lines is possible at any time (module is clamped pressure-free). Use of the pneumatic pressure booster no. 6370ZVL is recommended.

The clamping module has two connections:

- 1 = pneum. opening
- 2 = pneum. retensioning (turbo)

* Please observe the installation instructions.

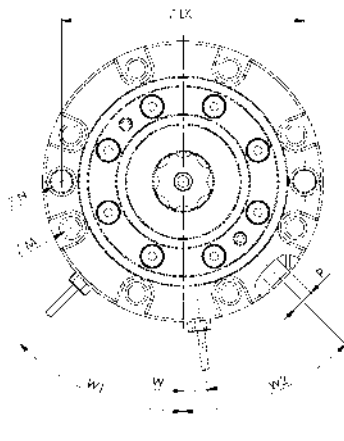
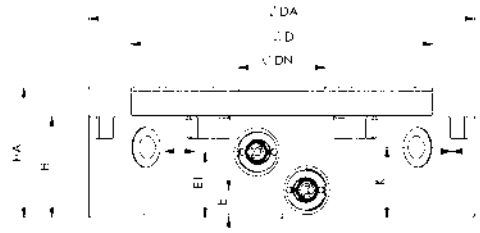
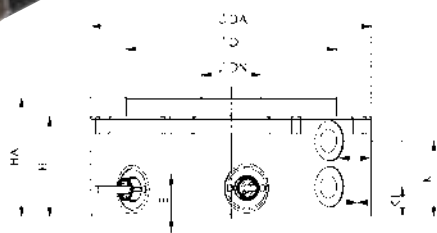

KP10

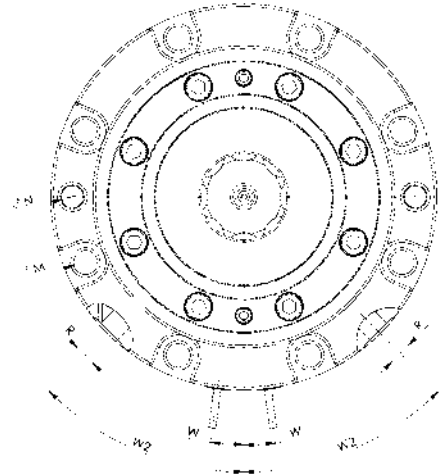

KP20, KP40

Dimensions:

Order no.	Size	dia. D	dia. DA	dia. DN	E	E1	H	HA	K	K1	dia. LK	dia. M	dia. N H7	R	W	W1	W2
		552963	KP10	78	104	22	10,0	-	37	44	28	11	90	6,6	8	G1/8	6,4°
552964	KP20	112	143	32	10,0	24	38	48	26	-	127	9,0	8	G1/8	7,5°	-	45°
552965	KP40	148	188	40	13,6	31	47	62	32	-	168	11,0	10	G1/8	5,0°	-	45°



CAD

Subject to technical alterations.



No. 6214RM-250

Clamping module, mechanical, screw-in version

Mechanical opening.
Housing and piston hardened.
Repetition accuracy < 0.1 mm.

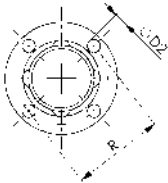
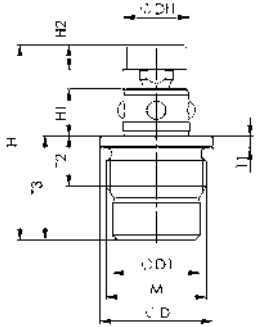

Order no.	Size	Pull-in/locking force up to	Holding force*	Weight
		[N]	[N]	[g]
559090	RM250	100	1000	26

Application:

Mechanical zero point clamping system for set-up-time-optimised clamping during non-cutting machining.

Note:

The mechanical zero-point clamping system is opened by pressing the actuator knob with hand force. Interlock is achieved mechanically via spring force. A tool is not required for this. The base plate serves as the contact surface, into which the clamping module is screwed. An extended actuating pin with a height of 20 mm is available under the order no. 561391. A suitable mounting tool is available under the order no. 559439. Order numbers of the clamping sleeves: 559092 and 559093.

* Please observe the installation instructions.

On request:

- Installation diagrams

Dimensions:

Order no.	Size	dia. D	dia. D1	dia. D2	ØDH	H	H1	H2	M	R	T1	T2	T3
559090	RM250	18	14	2,1	10,6	28,2 - 31,3	7,6	4	M16 x 1	14,75	1,95	8	16,7



Subject to technical alterations.

No. 6214RM-251

Clamping module with locking function, mechanical, screw-in version

Mechanical opening.
Housing and piston hardened.
Repetition accuracy < 0.1 mm.



NEW!

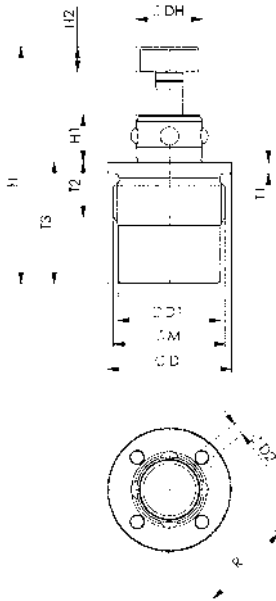

Order no.	Size	Pull-in/locking force up to	Holding force*	Weight
		[N]	[N]	[g]
567133	RM251	100	1000	28

Application:

Mechanical zero point clamping system with detent function for set-up-time-optimised clamping during non-cutting machining. Very suitable for clamping smaller fixtures, e.g. in assembly.

Note:

The mechanical zero-point clamping system is opened by pressing the actuator knob with hand force and it remains in this position. Locking involves pressing the actuator knob again mechanically using spring force. A tool is not required for this. The base plate serves as the contact surface, into which the clamping module is screwed. An extended actuating pin with a height of 20 mm is available under the order no. 561391. A suitable mounting tool is available under the order no. 559439.

* Please observe the installation instructions.

On request:

- Installation diagrams

Dimensions:

Order no.	Size	dia. D	dia. D1	dia. D2	ØDH	H	H1	H2	M	R	T1	T2	T3
567133	RM251	20	16,5	2,1	10,6	31,2 - 38,8	7,6	4	M18 x 1	14,75	1,95	9	19,7

No. 6208M

Clamping module, mechanical

Mechanical opening and closing.
Tempered steel, plasma-nitrided and burnished.
Repetition accuracy < 0.01 mm.

Order no.	Size	Pull-in/locking force up to [kN]	Holding force* [kN]	Tightening torque [Nm]	Weight [g]
559678	BM10	6	25	30	1064
562354	BM20	10	55	30	3330

Application:

Mechanical zero point clamping system for time-optimised clamping during cutting and non-cutting machining. Especially suitable for the modular design of clamping solutions via zero point clamping system.

Note:

The mechanical assembly clamping module has high holding, pull-in and locking forces. The clamping module can be positioned on the machine table and fastened with standard clamping elements at the circumferential clamping rim. The positioning bore for stop sleeves and a through-hole for fastening onto grid plates with countersunk head screws are present underneath (observe the max. permitted screw force). The mounting bore for the 20 pull-stud is also in the module.

Pull-stud: The zero point, timing or undersize pull-stud (without colour coding) can be used, depending on the application. The BM10 clamping module can only be used with the size 10 pull-studs in the M8 version, BM20 only with the size 20 pull-studs in the M12 version.

The fastening bolts are supplied as standard.

This clamping module can be used at ambient temperatures of up to max. 200°C.

* Please observe the installation instructions.

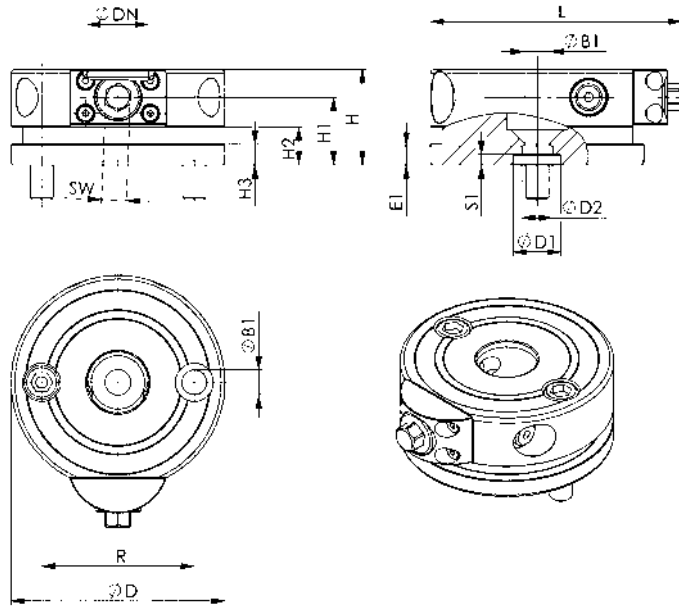

Dimensions:

Order no.	Size	dia. B1	dia. D	dia. D1 0/+0,01	dia. D2 F7	dia. DN	E1	H ±0.01	H1	H2	H3	L	R	S1	SW
559678	BM10	9,0	78	15	15	22	4,5	32	22,0	-	-	93	50	-	10
562354	BM20	13,5	112	25	16	32	10	50	35,5	20	11	132	80	5,5	13

CAD



Subject to technical alterations.

No. 6208IM

Clamping module, mechanical, with indexing

Mechanical opening and closing.
Tempered steel, plasma-nitrided and burnished.
Repetition accuracy < 0.01 mm.



Order no.	Size	Pull-in/locking force up to	Holding force*	Tightening torque	Weight
		[kN]	[kN]	[Nm]	[g]
559680	BM10	6	25	30	1031
562355	BM20	10	55	30	3295

Application:

Mechanical zero point clamping system with indexing grooves offset by 90° for time-optimised clamping during cutting and non-cutting machining.
Especially suitable for the modular design of clamping solutions via zero point clamping system.

Note:

The mechanical assembly clamping module with indexing notches offset by 90° has high holding, pull-in and locking forces.
The clamping module can be positioned on the machine table and fastened with standard clamping elements at the circumferential clamping rim.

The positioning bore for stop sleeves and a through-hole for fastening onto grid plates with countersunk head screws are present underneath (observe the max. permitted screw force). The mounting bore for the 20 pull-stud is also in the module.

Pull-stud: The zero point, timing or undersize pull-stud (without colour coding) can be used, depending on the application. The BM10 clamping module can only be used with the size 10 pull-studs in the M8 version, BM20 only with the size 20 pull-studs in the M12 version.

A cylinder pin, as well as fastening bolts for use with the support elements (6210S) or for use on a fixture, are supplied as standard.

This clamping module can be used at ambient temperatures of up to max. 200°C.
* Please observe the installation instructions.

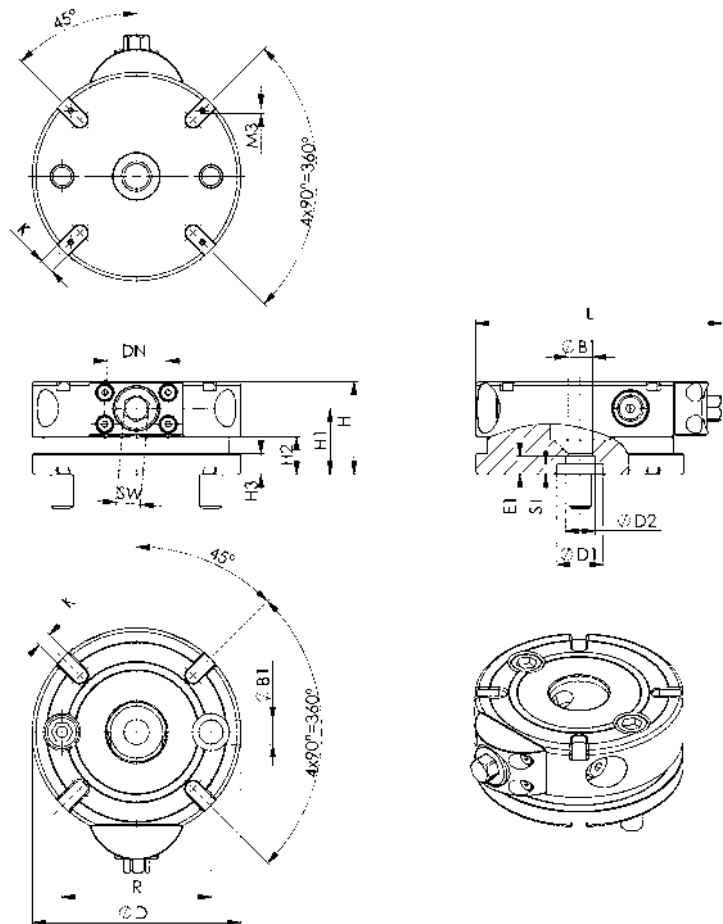

Dimensions:

Order no.	Size	dia. B1	dia. D	dia. D1 0/+0,01	dia. D2 F7	dia. DN	E1	H ±0.01	H1	H2	H3	K F6	L	R	S1	SW
559680	BM10	9,0	78	15	-	22	4,5	32	22,0	-	-	8	93	50	-	10
562355	BM20	13,5	112	25	16	32	10,0	50	35,5	20	11	8	132	80	5,5	13



No. 6208MD

Double clamping module, mechanical

Mechanical opening and closing.
Tempered steel, plasma-nitrided and burnished.
Repetition accuracy < 0.01 mm.

Order no.	Size	Pull-in/locking force up to	Holding force*	Tightening torque	Weight
		[kN]	[kN]	[Nm]	[Kg]
559681	BM10	6	25	30	1,6
562356	BM20	10	55	30	5,1

Application:

Mechanical „double clamping module“ for setting time-optimised clamping during cutting and non-cutting machining. Especially suitable for the modular design of clamping solutions via zero point clamping system.

Note:

This clamping system combines two separately operable mechanical zero-point clamping systems. In conjunction with the pull-stud for T-slots, this clamping module is simply and quickly fastened to the machine table via clamping slots. Additional height adapters, workpieces or fixtures can be fastened to the top with pull-studs.

Pull-stud: The zero point, timing or undersize pull-stud (without colour coding) can be used, depending on the application. The BM10 clamping module can only be used with the size 10 pull-studs in the M8 version, BM20 only with the size 20 pull-studs in the M12 version.

The fastening bolts are supplied as standard.

This clamping module can be used at ambient temperatures of up to max. 200°C.

* Please observe the installation instructions.

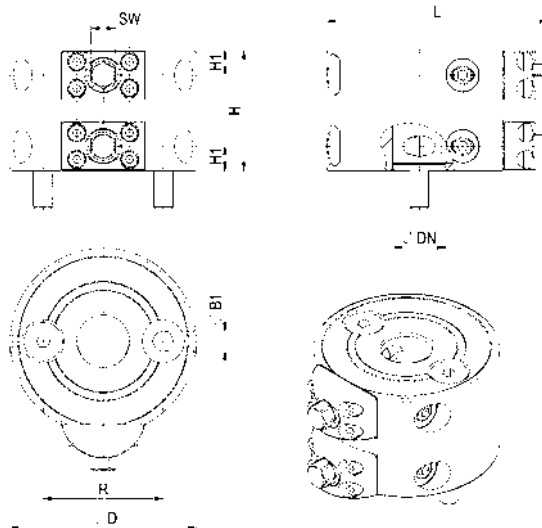

Dimensions:

Order no.	Size	dia. B1	dia. D	dia. DN	H ±0.01	H1	L	R	SW
559681	BM10	9,0	77,5	22	50	10,2	92	50	10
562356	BM20	13,5	112,0	32	80	15,0	132	80	13

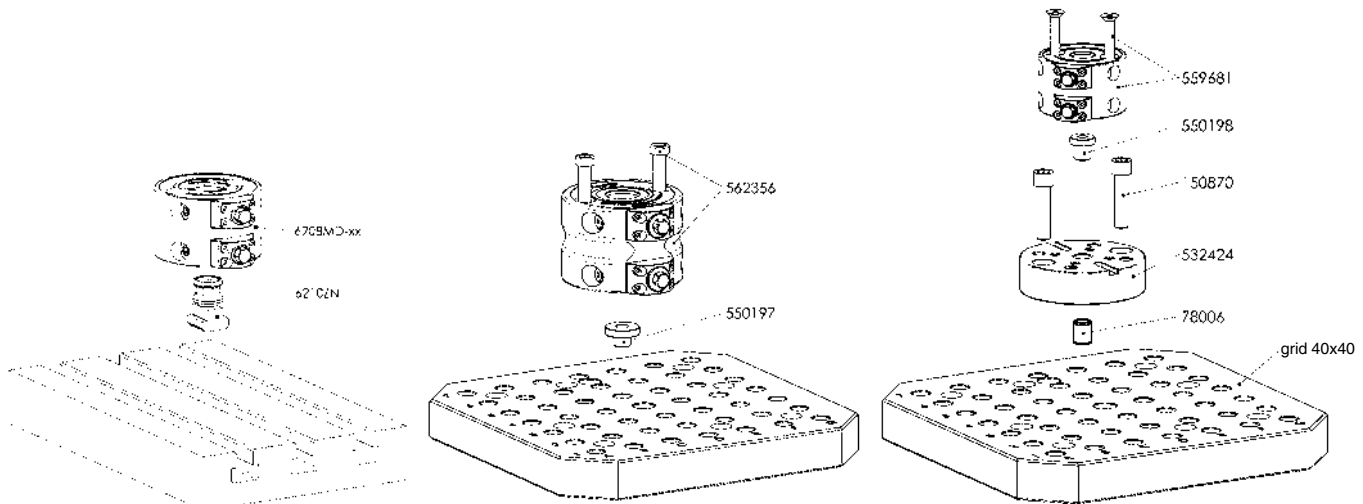

Subject to technical alterations.

No. 6210ZN

Pull-stud for T-slots

Order no.	Size	A	dia. DN	G	H	L	Weight [g]
550438	10	10	22	M8	16	30	48
550439	10	12	22	M8	16	35	51
550440	10	14	22	M8	16	35	54
550441	20	14	32	M12	23	45	143
550442	20	16	32	M12	23	45	147
550443	20	18	32	M12	23	50	157

Application:

The pull-stud for T-slots enables the AMF zero-point clamping system to be positioned and clamped directly to the machine table by means of clamping slots.

These pull-studs can be used for pneumatic, hydraulic and mechanical clamping modules, and also for mechanical double clamping modules.

Advantage:

Simple, quick and flexible clamping of workpieces on the machine table with varying clearances of the pull-stud bores.

Note:

Supplied as standard is, as shown:

- zero point pull-studs with slot (dimension A)
- T-nut
- countersunk head screw (strength class 10.9)

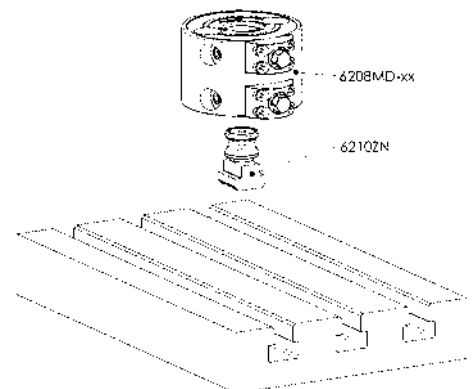
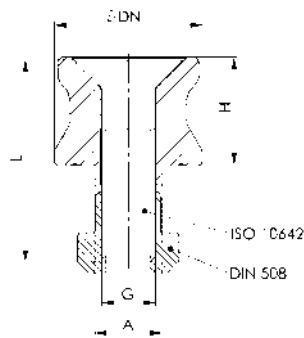

Subject to technical alterations.



No. 6212M

Clamping module, mechanical

Open and close mechanically.
Tool steel, hardened.
Repetition accuracy < 0.01 mm.



Order no.	Size	Pull-in/locking force up to	Holding force*	Weight
		[kN]	[kN]	[g]
553405	BM10	10	17	360
559094	BM20	20	43	1330

Application:

Mechanical zero point clamping system for setting time-optimised clamping during cutting or non-cutting machining. Particularly suitable for the modular design of clamping solutions via zero point clamping system.

Note:

The mechanical zero-point clamping system has high holding, pull-in and locking forces. The B10 clamping module is fastened centrally with an M8 flat-head screw, the BM20 clamping module with an M12 cylinder screw.

The BM20 clamping module can only be used with the B20 pull-studs in the M12 version.

To open and close the clamping modules, we recommend the following AMF hook spanner:

- size 10= order no. 54940
- size 20= order no. 54973

A cylinder pin is supplied as standard. In addition, fastening bolts for use with the support elements (order no. 532390, 532374) and for use on a fixture are included.

* Please observe the installation instructions.

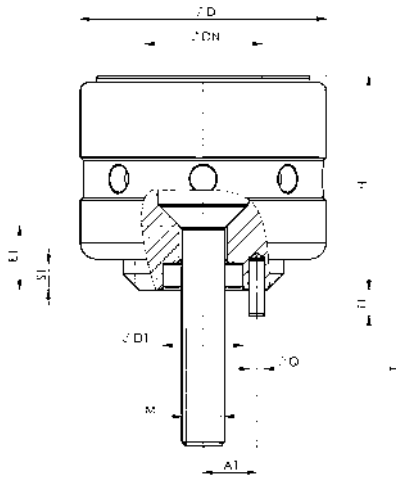

Dimensions:

Order no.	Size	A1	dia. D	dia. D1 0/+0,01	dia. DN	E1	H ±0.01	M	dia. Q	S1	T	T1
553405	BM10	10	46	15	22	12	40	M8	3	5,0	29	4,9
559094	BM20	16	70	25	32	14	60	M12	4	5,5	16	5,2

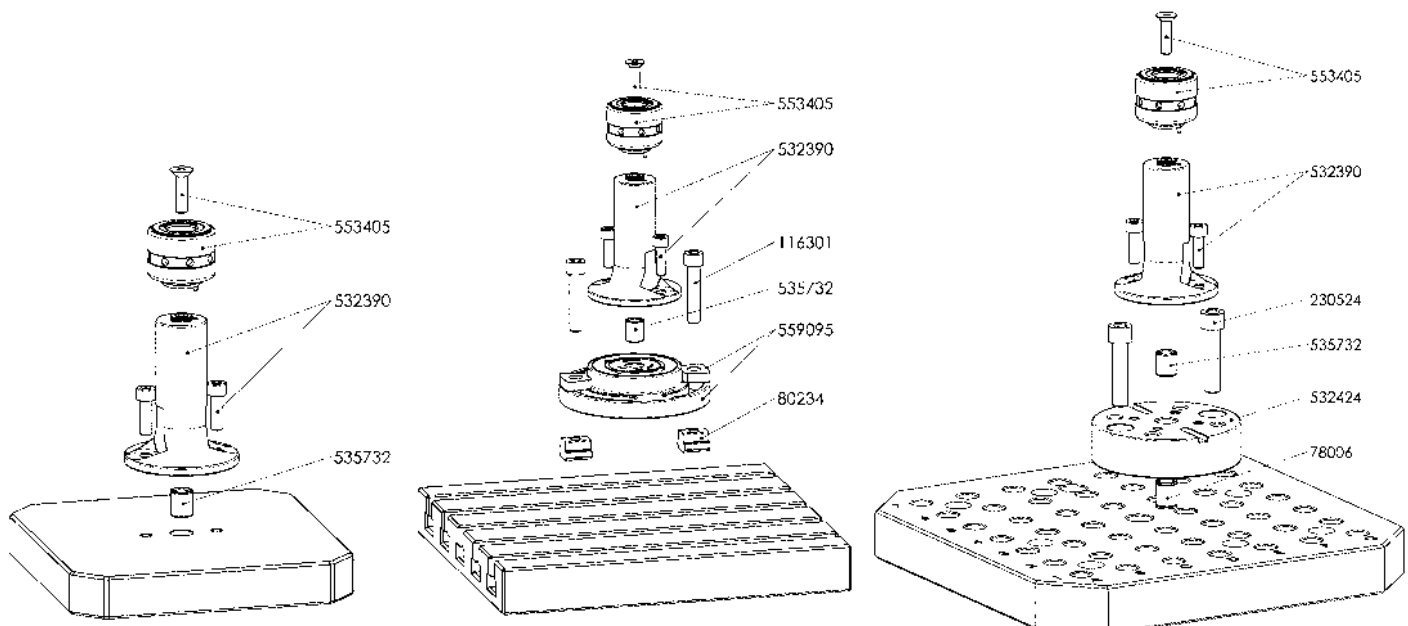

Subject to technical alterations.



SIMPLY CLEVER COMBINATIONS - MODULAR HEIGHT ADAPTER FOR YOUR FLEXIBLE PRODUCTION

With the new modular height adapters from AMF, your production becomes even more flexible and economical. Cleverly combined, you now have an efficient opportunity to adapt your production process more simply, flexibly and quickly to constantly changing requirements.

ASSEMBLY ELEMENT



INTERMEDIATE ELEMENTS



FOOT ELEMENTS



BASE ELEMENTS



The modular height adapters consist of three levels. The foot elements form the interface to the existing machine table. Building on this and with the use of intermediate elements, every clamping height can be achieved and, by combining different sizes, adapted flexibly to the contour of the workpiece.

Assembly elements with integrated zero point clamping modules of the AMF Zero Point system complete the adapters. Through this, the workpiece is clamped in a process-reliable way.

THE ADVANTAGES:

- > Simple direct clamping of the workpiece
- > Convenient 5-sided processing
- > Flexibly adaptable to every workpiece size and thickness
- > Freely selectable standard dimension



No. 6210H-10-05

Adapter clamping module B10 to BH5, hydr.

Housing: tempered steel, gas-nitrided and oxidised.
Clamping module: cover and piston hardened.



Order no.	Size	Pull-in/locking force up to	Holding force*	Weight
		[kN]	[kN]	[g]
534776	BH5	5	13	2328

Application:

The adapter element is used to reduce the intermediate element size B10 to the hydraulic clamping module BH5. Workpieces or fixtures can be clamped with repetition accuracy directly onto the hydraulic clamping module BH5 using pull-studs.

This clamping system can be used to move workpieces to the required machining height in the machine for 5-sided machining, or for the safe and quick clamping of workpieces with ledges and different clamping heights on the machine table.

Advantage:

Simple, quick and flexible clamping of complex workpiece contours on the machine table. Especially suitable for levelling workpieces or clamping fixtures at the necessary machine heights in the machine tool and for the reliable clamping of same.

Note:

Order no. for the centering sleeve \varnothing 15 mm: 535732

The hydr. quick-release coupling, connector version, and the fastening screws are supplied as standard.

* Please observe the installation instructions.

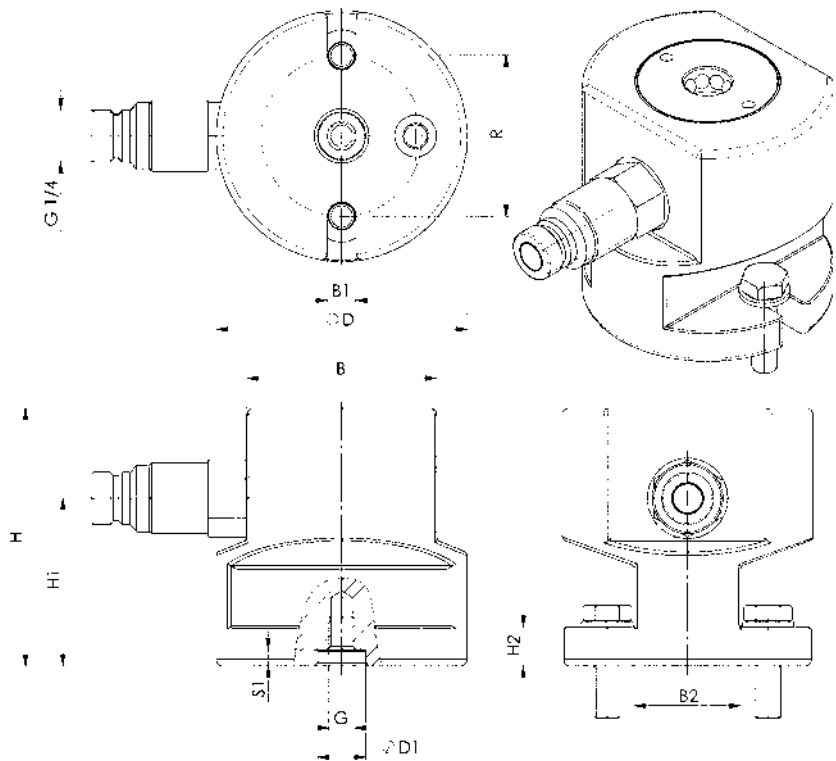

Dimensions:

Order no.	Size	B	B1	B2	dia. D	\varnothing D1 F7	G	H ± 0.01	H1	H2	R	S1
534776	BH5	59	9	33	78	15	M8	80	52	12	50	5



No. 6210IH-10-05

Adapter clamping module B10 to BH5, hydr. with indexing

Housing: tempered steel, gas-nitrided and oxidised.
Clamping module: cover and piston hardened.



Order no.	Size	Pull-in/locking force up to	Holding force*	Weight
		[kN]	[kN]	[g]
534719	BH5	5	13	2318

Application:

The adapter element is used to reduce the intermediate element size B10 to the hydraulic clamping module BH5. Workpieces or fixtures can be clamped with repetition accuracy directly onto the hydraulic clamping module BH5 using pull-studs.

This clamping system can be used to move workpieces to the required machining height in the machine for 5-sided machining, or for the safe and quick clamping of workpieces with ledges and different clamping heights on the machine table.

Thanks to the indexing option, workpieces under large machining forces can be secured to prevent radial distortion.

Advantage:

Simple, quick and flexible clamping of complex workpiece contours on the machine table. Especially suitable for levelling workpieces or clamping fixtures at the necessary machine heights in the machine tool and for the reliable clamping of same.

Note:

Order no. for the centering sleeve \varnothing 15 mm: 535732

Order no. for the slot nuts: 430264

The hydr. quick-release coupling, connector version, and the fastening screws are supplied as standard.

* Please observe the installation instructions.

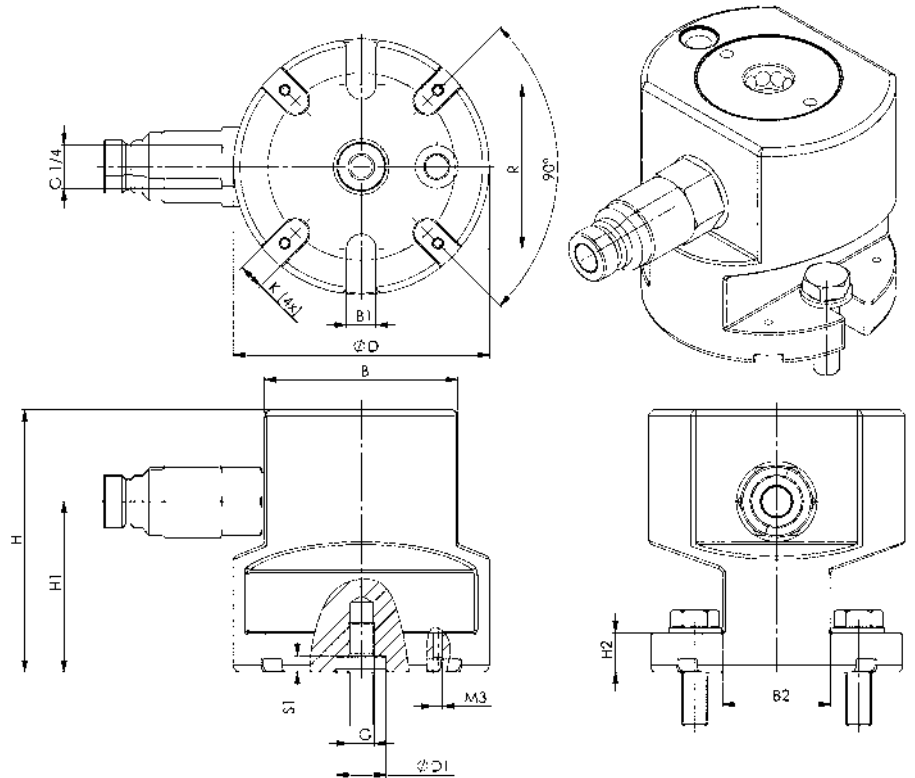

Dimensions:

Order no.	Size	B	B1	B2	dia. D	\varnothing D1 F7	G	H ± 0.01	H1	H2	K F6	R	S1
534719	BH5	59	9	33	78	15	M8	80	52	12	8	50	5



No. 6210L-10-05

Adapter clamping module B10 to BP5, pneum.

Housing: tempered steel, gas-nitrided and oxidised.
Clamping module: cover and piston hardened.

Order no.	Size	Pull-in/locking force up to	Holding force*	Weight
		[kN]	[kN]	[g]
534768	BP5	1,5	13	2272

Application:

The adapter element is used to reduce the intermediate element size B10 to the pneumatic clamping module BP5. Workpieces or fixtures can be clamped with repetition accuracy directly onto the pneumatic clamping module BP5 using pull-studs.

This clamping system can be used to move workpieces to the required machining height in the machine for 5-sided machining, or for the safe and quick clamping of workpieces with ledges and different clamping heights on the machine table.

Advantage:

Simple, quick and flexible clamping of complex workpiece contours on the machine table. Especially suitable for levelling workpieces or clamping fixtures at the necessary machine heights in the machine tool and for the reliable clamping of same.

Note:

Order no. for the centering sleeve \varnothing 15 mm: 535732

The pneum. quick-release coupling, connector version, and the fastening screws are supplied as standard.

* Please observe the installation instructions.

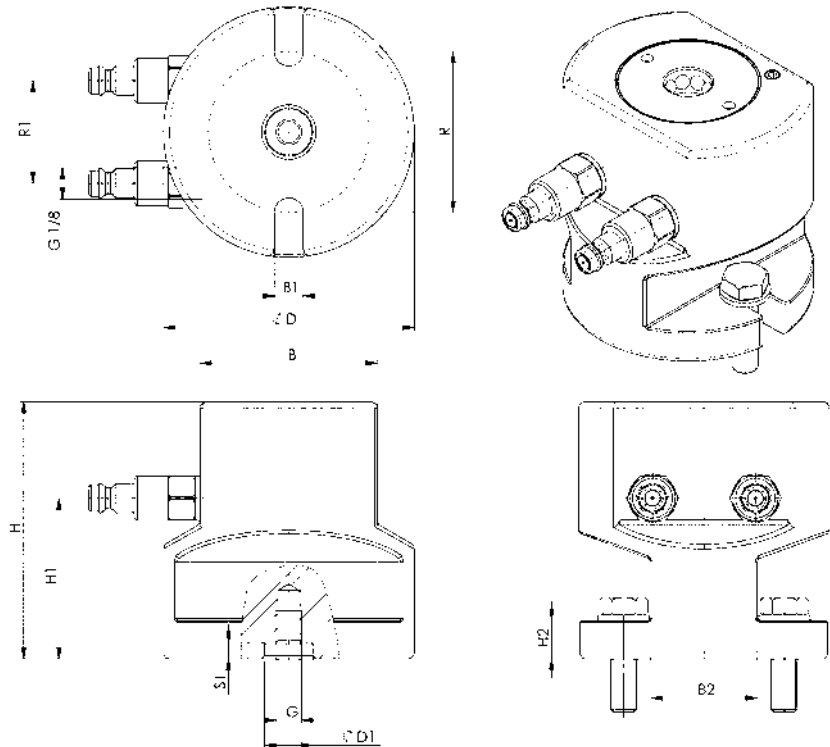

Dimensions:

Order no.	Size	B	B1	B2	dia. D	\varnothing D1 F7	G	H ± 0.01	H1	H2	R	R1	S1
534768	BP5	59	9	33	78	15	M8	80	52	12	50	32	5



No. 6210IL-10-05

Adapter clamping module B10 to BP5, pneum. with indexing

Housing: tempered steel, gas-nitrided and oxidised.
Clamping module: cover and piston hardened.



Order no.	Size	Pull-in/locking force up to	Holding force*	Weight
		[kN]	[kN]	[g]
532853	BP5	1,5	13	2248

Application:

The adapter element is used to reduce the intermediate element size B10 to the pneumatic clamping module BP5. Workpieces or fixtures can be clamped with repetition accuracy directly onto the pneumatic clamping module BP5 using pull-studs.

This clamping system can be used to move workpieces to the required machining height in the machine for 5-sided machining, or for the safe and quick clamping of workpieces with ledges and different clamping heights on the machine table.

Thanks to the indexing option, workpieces under large machining forces can be secured to prevent radial distortion.

Advantage:

Simple, quick and flexible clamping of complex workpiece contours on the machine table. Especially suitable for levelling workpieces or clamping fixtures at the necessary machine heights in the machine tool and for the reliable clamping of same.

Note:

Order no. for the centering sleeve $\varnothing 15$ mm: 535732

Order no. for the slot nuts: 430264

The pneum. quick-release coupling, connector version, and the fastening screws are supplied as standard.

* Please observe the installation instructions.

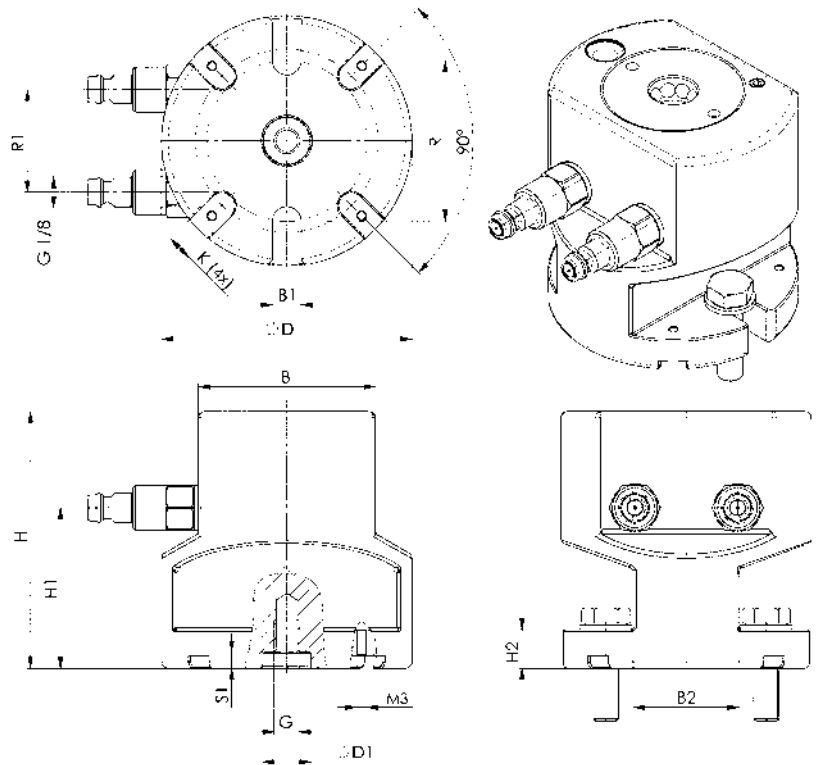

Dimensions:

Order no.	Size	B	B1	B2	dia. D	$\varnothing D1$ F7	G	H ± 0.01	H1	H2	K F6	R	R1	S1
532853	BP5	59	9	33	78	15	M8	80	52	12	8	50	32	5



CAD

No. 6210H

Assembly element BH10 and BH20, hydraulic

Housing: tempered steel, gas-nitrided and oxidised.
Clamping module: cover and piston hardened.

Order no.	Size	Pull-in/locking force up to	Holding force*	Weight
		[kN]	[kN]	[g]
534883	BH10	10	25	2835
534800	BH20	20	55	7311

Application:

The assembly element is used to clamp with repetition accuracy workpieces or fixtures directly onto the hydraulic clamping modules BH10 or BH20 via pull-studs.

This clamping system can be used to move workpieces to the required machining height in the machine for 5-sided machining, or for the safe and quick clamping of workpieces with ledges and different clamping heights on the machine table.

Advantage:

Simple, quick and flexible clamping of complex workpiece contours on the machine table. Especially suitable for levelling workpieces or clamping fixtures at the necessary machine heights in the machine tool and for the reliable clamping of same.

Note:

Order numbers for the centering sleeves

- Ø 15 mm: 535732

- Ø 16 mm: 78006

The hydr. quick-release coupling, connector version, and the fastening screw are supplied as standard.

* Please observe the installation instructions.

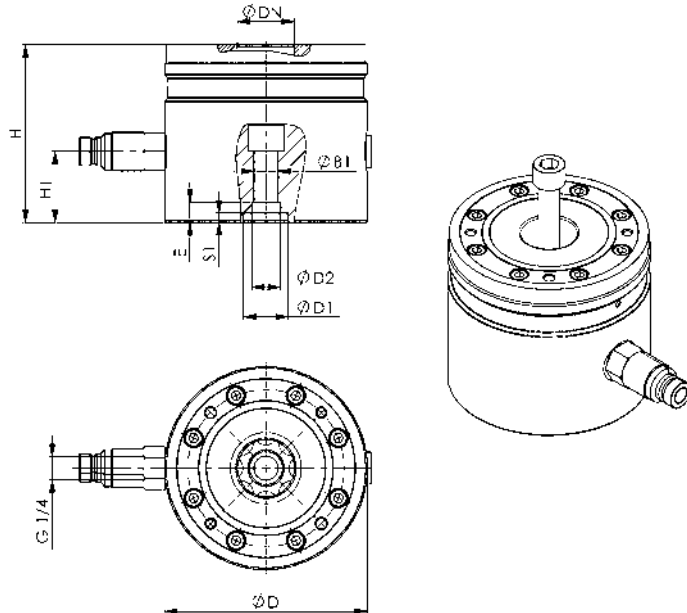

Dimensions:

Order no.	Size	dia. B1	dia. D	dia. D1 0/+0,01	dia. D2 F7	dia. DN	E	H ±0.01	H1	S1
534883	BH10	9,0	80	-	15	22	5,0	80	35	-
534800	BH20	13,5	114	25	16	32	11,25	100	40	5,5



CAD

Subject to technical alterations.

No. 6210IH

Assembly element BH20, hydraulic, with indexing

Housing: tempered steel, gas-nitrided and oxidised.
Clamping module: cover and piston hardened.



Order no.	Size	Pull-in/locking force up to	Holding force*	Weight
		[kN]	[kN]	[g]
534412	BH20	20	55	7154

Application:

The assembly element is used to clamp with repeat accuracy workpieces or fixtures directly onto the hydraulic clamping module BH20 with 4-point indexing via pull-studs.

This clamping system can be used to move workpieces to the required machining height in the machine for 5-sided machining, or for the safe and quick clamping of workpieces with ledges and different clamping heights on the machine table.

Advantage:

Simple, quick and flexible clamping of complex workpiece contours on the machine table. Especially suitable for levelling workpieces or clamping fixtures at the necessary machine heights in the machine tool and for the reliable clamping of same.

Note:

Order no. for the centering sleeve $\varnothing 16$ mm: 78006

Order no. for the slot nuts: 430264

The hydr. quick-release coupling, connector version, and the fastening screw are supplied as standard.

* Please observe the installation instructions.

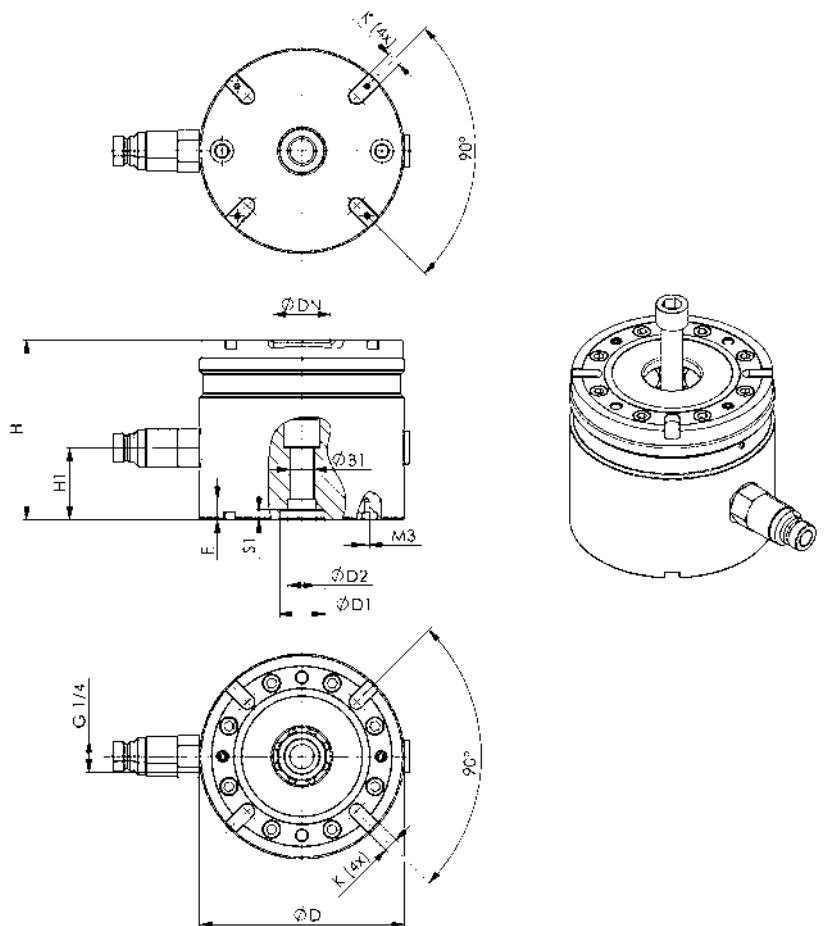

Dimensions:

Order no.	Size	dia. B1	dia. D	dia. D1 0/+0,01	dia. D2 F7	dia. DN	E	H ± 0.01	H1	K F6	S1
534412	BH20	13,5	114	25	16	32	11,25	100	40	8	5,5



No. 6370ZSZ-112

Collet attachment for clamping module KH20 and BH20, hydr.

Material: high-strength aluminium.

Order no.	dia. D	dia. D1	ØD2 0/+0.01	Clamping stroke Ø [mm]	H	H1	Weight [g]
550286	112	20	25	0,5	50	30	1133

Design:

The collet attachment with a diameter of 112 mm is suitable for the AMF zero-point hydraulic clamping modules KH20 (Order no. 428425) and BH20 (Order no. 534412) with indexing. The collet is made from anodised, high-strength aluminium.

Application:

The collet attachment is placed on the AMF Zero Point clamping system size KH20 or BH20 in the hydraulic version and guides the radial clamping force to the workpiece after the clamping module is closed. The workpiece contour is milled into the collet attachment with a minimum clamping depth of 2 mm. The collet attachment can be milled off to a height of H1, allowing new workpiece contours to be introduced. The maximum workpiece diameter is 100 mm.

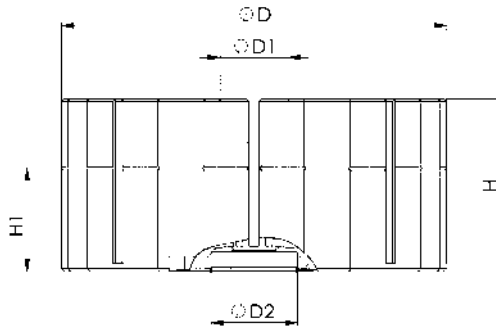
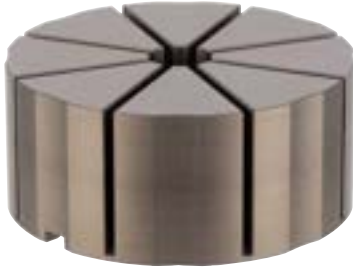

CAD



No. 6370ZSB

Mounting kit for collet attachment

for collet No. 6370ZSZ-112

Order no.	Size	Weight [g]
550287	20	190

Design:

The mounting set includes:

- 1 pull-stud size 20, design: sword
- 1 captive screw size 20
- 1 lock nut M12
- 2 indexing notches, width 8 mm

Application:

The mounting set is mounted with the collet attachment 112 mm, order no. 550286. After installation, the collet attachment can be securely and hydraulically clamped onto the AMF clamping modules, size 20.



CAD



Subject to technical alterations.

**Collet attachment for clamping
module KH20 and BH20, hydr.**
550286

**Mounting kit for collet
attachment**
550287

**Assembly element BH20,
hydraulic, with indexing**
534412



Subject to technical alterations.

No. 6210L

Assembly element BP10, BP10.3 and BP20, pneumatic

Housing: tempered steel, gas-nitrided and oxidised.
Clamping module: cover and piston hardened.

Order no.	Size	Pull-in/locking force up to	Holding force*	Weight
		[kN]	[kN]	[g]
534925	BP10	8	25	2720
534537	BP10.3	10	25	7708
534842	BP20	17	55	7185

Application:

The assembly element is used to clamp with repetition accuracy workpieces or fixtures directly onto the pneumatic clamping modules BP10, BP10.3 and BP20 via pull-studs.
This clamping system can be used to move workpieces to the required machining height in the machine for 5-sided machining, or for the safe and quick clamping of workpieces with ledges and different clamping heights on the machine table.

Advantage:

Simple, quick and flexible clamping of complex workpiece contours on the machine table. Especially suitable for levelling workpieces or clamping fixtures at the necessary machine heights in the machine tool and for the reliable clamping of same.

Note:

Order numbers for the centering sleeves

- Ø 15 mm: 535732
- Ø 16 mm: 78006

The pneum. quick-release coupling, connector version, and the fastening screw are supplied as standard.

* Please observe the installation instructions.

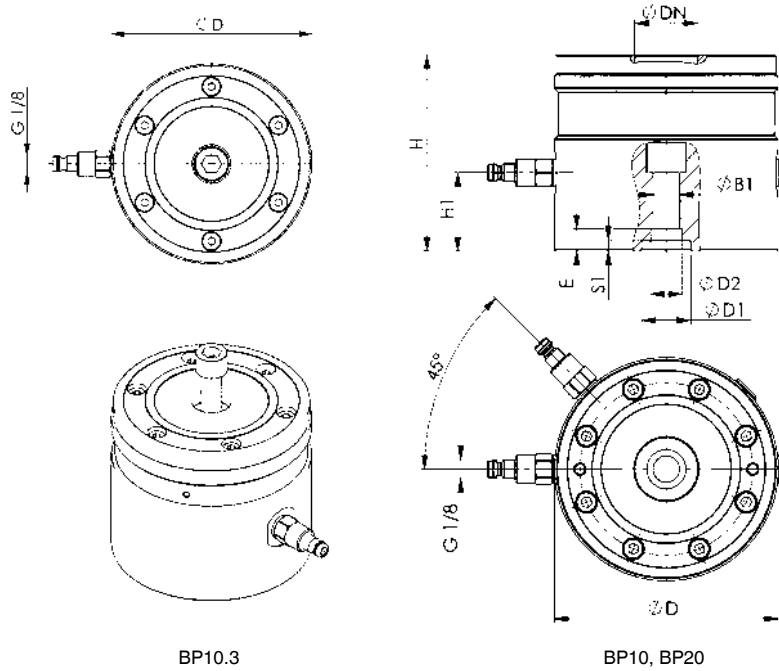

Dimensions:

Order no.	Size	dia. B1	dia. D	dia. D1 0/+0,01	dia. D2 F7	dia. DN	E	H ±0.01	H1	S1
534925	BP10	9,0	80	-	15	22	5,0	80	35	-
534537	BP10.3	13,5	114	25	16	22	11,25	100	40	5,5
534842	BP20	13,5	114	25	16	32	11,25	100	40	5,5



CAD

Subject to technical alterations.

No. 6210IL

Assembly element BP10.3 and BP20, pneumatic, with indexing

Housing: tempered steel, gas-nitrided and oxidised.
Clamping module: cover and piston hardened.



Order no.	Size	Pull-in/locking force up to	Holding force*	Weight
		[kN]	[kN]	[g]
534495	BP10.3	10	25	7668
534453	BP20	17	55	7162

Application:

The assembly element is used to clamp workpieces or fixtures with repetition accuracy directly onto the pneumatic clamping modules BP10.3 and BP20 using pull-studs.

This clamping system can be used to move workpieces to the required machining height in the machine for 5-sided machining, or for the safe and quick clamping of workpieces with ledges and different clamping heights on the machine table.

Thanks to the quadruple 90° indexing option, workpieces under large machining forces can be secured to prevent radial distortion.

Advantage:

Simple, quick and flexible clamping of complex workpiece contours on the machine table. Especially suitable for levelling workpieces or clamping fixtures at the necessary machine heights in the machine tool and for the reliable clamping of same.

Note:

Order no. for the centering sleeve \varnothing 16 mm: 78006

Order no. for the slot nuts: 430264

The pneum. quick-release coupling, connector version, and the fastening screw are supplied as standard.

* Please observe the installation instructions.

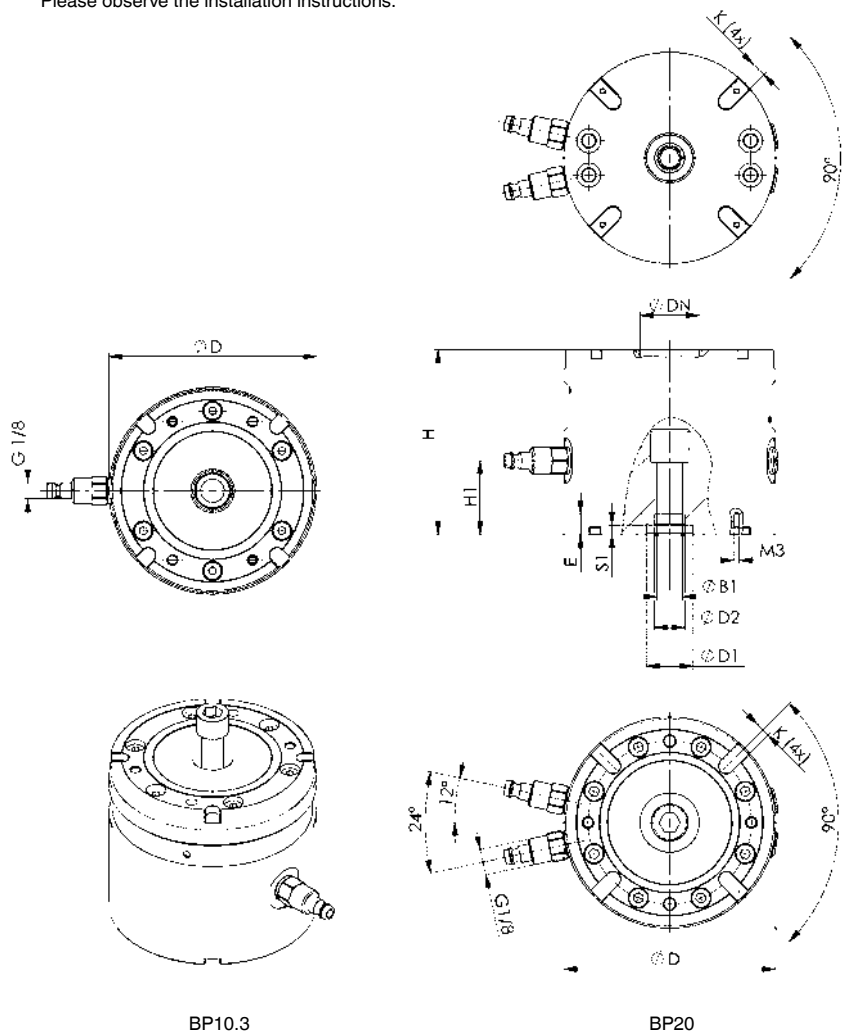

Dimensions:

Order no.	Size	dia. B1	dia. D	dia. D1 0/+0,01	dia. D2 F7	dia. DN	E	H ± 0.01	H1	K F6	S1
534495	BP10.3	13	114	25	16	22	11,25	100	40	8	5,5
534453	BP20	13	114	25	16	32	11,25	100	40	8	5,5



No. 6210S

Support element, fixed

Housing: tempered steel, gas-nitrided and oxidised.

Order no.	Size	H ±0.01	Weight [g]
532390	B10	100	995
532374	B20	100	1790

Application:

The support element enables workpieces to be received into the bore for the pull-stud, depending on size (10 or 20) and to be clamped to the main or the intermediate element.

This clamping system can be used to move workpieces to the required machining height in the machine for 5-sided machining, or for the safe and quick clamping of workpieces with ledges and different clamping heights on the machine table.

Advantage:

Simple, quick and flexible clamping of complex workpiece contours on the machine table. Especially suitable for levelling workpieces or clamping fixtures at the necessary machine heights in the machine tool and for the reliable clamping of same.

Note:

Two fastening bolts and a threaded stud are supplied as standard.

Order numbers of the centring sleeves

- Ø15: order no. 535732
- Ø16: order no. 78006
- Ø22: order no. 78238

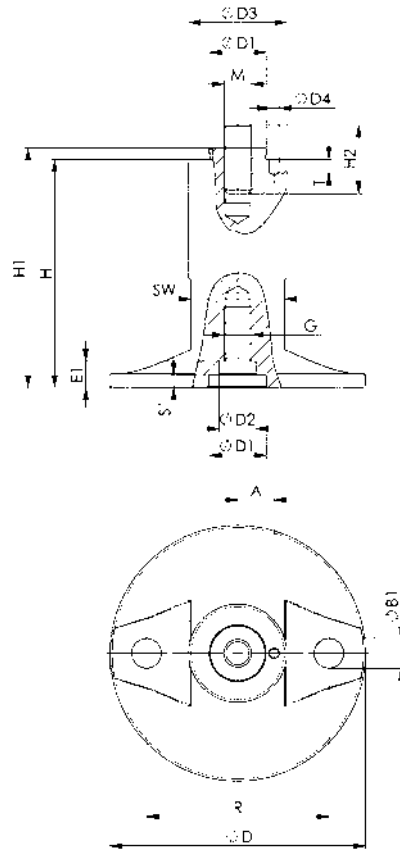

Dimensions:

Order no.	Size	A	dia. B1	dia. D	dia. D1 0/+0,01	dia. D2 F7	dia. D3	dia. D4	E1	G	H1	H2	M	R	S1	SW	T
532390	B10	10	9	78	-	15	35	3,1	-	M8	103	20	M8	50	5	30	6
532374	B20	16	13	112	25	16	43	4,1	12,0	M12	105	30	M12	80	6	41	6

CAD



Subject to technical alterations.

No. 6210S

Support element, adjustable ± 5 mm

Housing: tempered steel, gas-nitrided and oxidised.



Order no.	Size	H ± 0.01	Weight [g]
532416	B10	95-105	974
532432	B20	95-105	2020

Application:

The support element enables workpieces to be received into the bore for the pull-stud, depending on size (10 or 20) and to be clamped to the main or the intermediate element. Thanks to the adjustment and counter option, the support element can be steplessly adapted to the workpiece contour by ± 5 mm.

This clamping system can be used to move workpieces to the required machining height in the machine for 5-sided machining, or for the safe and quick clamping of workpieces with ledges and different clamping heights on the machine table.

Advantage:

Simple, quick and flexible clamping of complex workpiece contours on the machine table. Especially suitable for levelling workpieces or clamping fixtures at the necessary machine heights in the machine tool and for the reliable clamping of same.

Note:

Order numbers for the centering sleeves:

- $\varnothing 15$: Order no. 535732
- $\varnothing 16$: Order no. 78006
- $\varnothing 22$: Order no. 78238

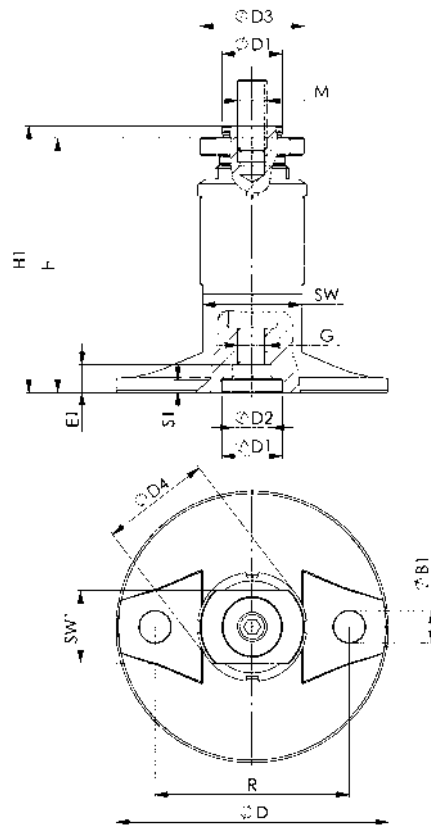

Dimensions:

Order no.	Size	dia. B1	dia. D	dia. D1 0/+0,01	dia. D2 F7	dia. D3	dia. D4	E1	G	H1	M	R	S1	SW	SW1
532416	B10	9	78	-	15	35	38	5,0	M8	98-108	M8	50	4,5	30	27
532432	B20	13	112	25	16	43	45	11,5	M12	100-110	M12	80	5,5	41	30



No. 6210AGS

Adapter with straight clamp

Adapter made from tempered steel, plasma-nitrided and burnished. Clamp burnished from tempered steel.

NEW!



Order no.	Size	H ±0,1	H1	Weight [g]
567136	B10	28	15 - 40	1225
567137	B20	40	15 - 45	3600

Application:

The adapter is used with a straight clamp to implement the first clamping of a workpiece by the AMF modular system. For this, the adapter can be clamped to basic or intermediate elements of sizes B10 and B20, or to clamping modules BH10, BP10, BH20, BP20.

The adapter has an integrated stop for the workpiece and a supporting spring element to hold the clamp in position which simplifies handling. The clamping height is variable and different compression pieces can be used to adapt to the clamp.

Advantage:

Simple, quick and flexible clamping of complex workpiece contours on the machine table. Especially suitable for moving workpieces into the required height for machining in the machine tool and to clamp it safely.

Note:

The fastening bolts are supplied as standard. Suitable compression pieces, e.g. 7110DIX-**xM** and 7110DKX-**xM** can be found in the AMF „Standard clamping elements“ catalogue.

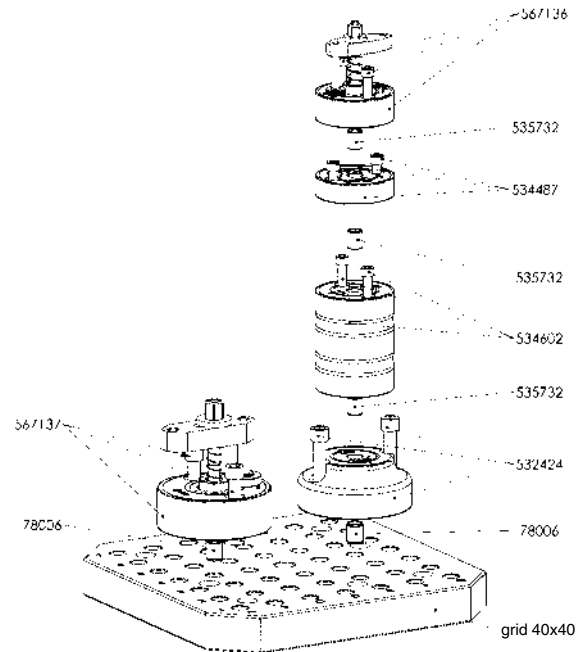
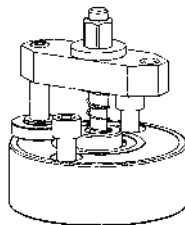
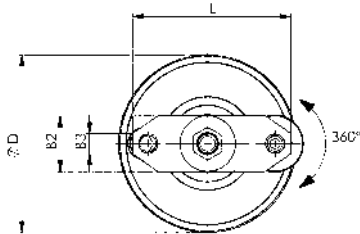
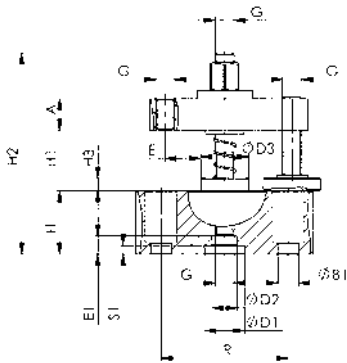

Dimensions:

Order no.	Size	A	dia. B1	B2	B3	dia. D	dia. D1 ±0.01	dia. D2 F7	dia. D3	E	E1	Cylinder screw ISO 4762	G	H2	H3	L	R	S1
567136	B10	12	9	25	8	78	-	15	24	10,0 - 20,0	5,0	M8 x 30	M8	9	8	70	50	-
567137	B20	20	13	35	13	112	25	16	30	15,5 - 32,0	11,5	M12 x 25, M12 x 50	M12	127	8	100	80	5,5

Subject to technical alterations.

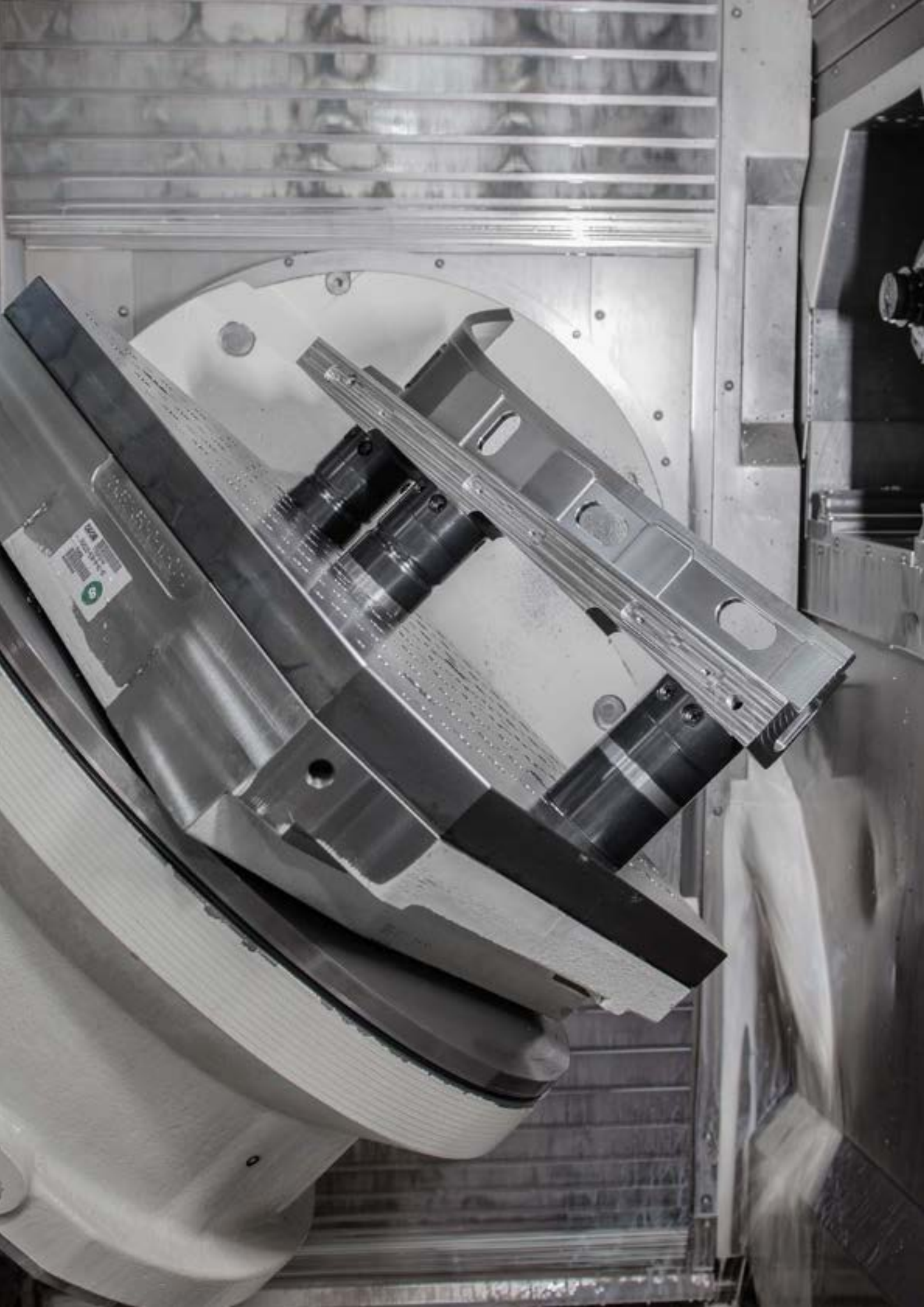

No. 6209MXY

Counterbalance element XY-plane

Mechanical opening and clamping.
Tempered steel, plasma-nitrided.

Order no.	Size	Shear force [kN]	XY counterbalance [mm]	Tightening torque Md max. [Nm]	Weight [Kg]
558905	B10	3	4	30	1300
558906	B20	7	4	40	3400

Application:

The counterbalance element can compensate for a position tolerance of up to 4 mm in the plane. It is used to compensate for distance tolerances of the pull-studs. The upper part can be pushed to the base in the opened condition and is clamped without twisting by actuating the clamping screw.

Advantage:

Simple, quick and flexible clamping on the machine table of complex workpiece contours with large pull-stud distance tolerances.

Note:

The fastening bolts are supplied as standard.



Dimensions:

Order no.	Size	dia. B1	dia. D	E1	G	H	H1	H2	L	ØR	SW	W
558905	B10	9,0	78	19,4	M8	40	17	28	93	50	10	30°
558906	B20	13,5	112	22,4	M12	50	20	35	132	80	13	45°

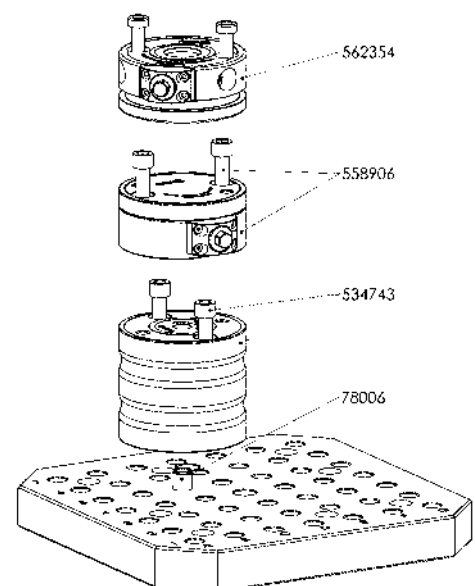
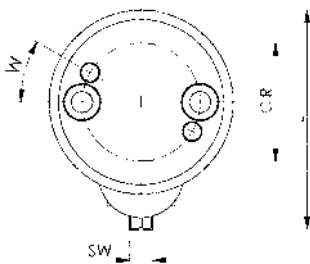
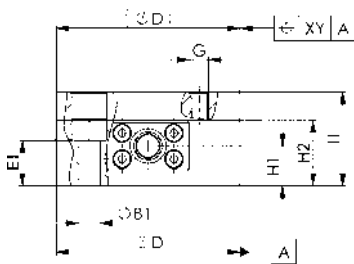

CAD

Subject to technical alterations.

No. 6209MZ

Height adjustment element

Mechanical clamping.
Tempered steel, plasma-nitrided.



Order no.	Size	Contact force F1	Support force F2	Tightening torque Md max.	Weight
		[N]	[kN]	[Nm]	[Kg]
554058	B10	44 - 52	12	30	3,5
558903	B20	100 - 122	20	30	6,9

Application:

The height counterbalance element is used to clamp a workpiece distortion-free, beginning with the fourth support point. The element attaches itself by spring force and is then fastened by turning the clamping screw. The height counterbalance element is normally extended.

This element can also be used as a support element to prevent bending and vibration of the workpieces.

Advantage:

Simple, quick and flexible clamping of complex workpiece contours on the machine table. Particularly suitable for levelling workpieces or clamping fixtures at the necessary machine heights in the machine tool for clamping these securely.

Note:

The fastening bolts are supplied as standard.

Order number of the centring sleeves:

- size B10: order no. 535732 and 430223

- size B20: order no. 78006

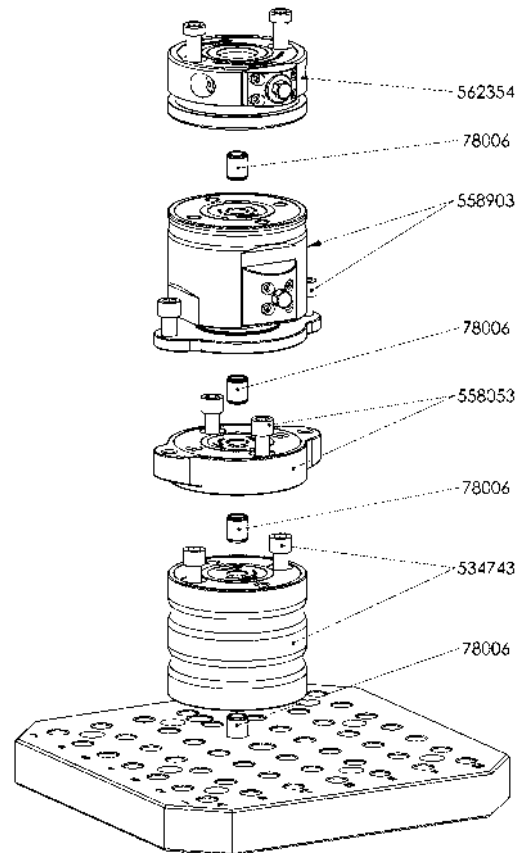
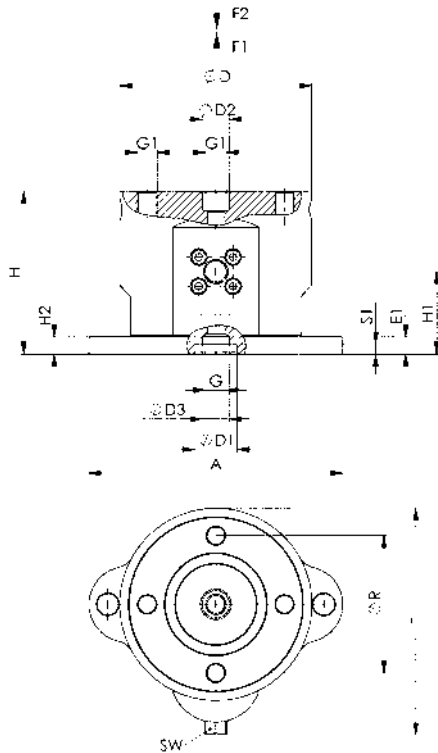

Dimensions:

Order no.	Size	A	dia. D	dia. D1 0/+0,01	dia. D2 F7	dia. D3	E1	G	G1	H	H1	H2	L	ØR	SW	S1
554058	B10	105	78	25	15	-	-	M12	M8	95-105	48	10	96	50	10	5,5
558903	B20	148	112	25	16	16	10	M12	M12	95-105	48	10	132	80	13	5,5

Subject to technical alterations.

No. 6210Z

Intermediate element

Tempered steel, plasma-nitrided and burnished.



height 20, 28 and 30 mm

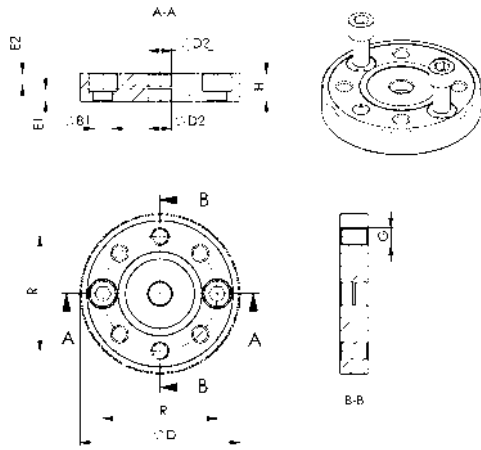

from height 40 mm

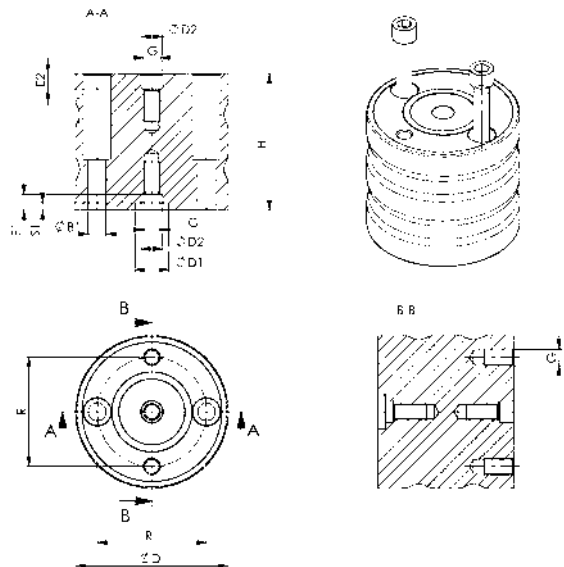

Order no.	Size	H ±0.01	Weight [g]
534487	B10	20	667
559683	B10	28	1000
534503	B10	30	1012
534529	B10	40	1353
534545	B10	50	1698
534560	B10	60	2043
534586	B10	80	2731
534602	B10	100	3443
534628	B20	20	1394
534644	B20	30	2092
534669	B20	40	2800
534685	B20	50	3508
534701	B20	60	4225
534727	B20	80	5661
534743	B20	100	7012

Application:

The intermediate elements are used as height adapters for workpieces and clamping fixtures, and are mounted to the main elements. Workpieces are clamped by means of assembly elements. This clamping system can be used to move workpieces to the required machining height in the machine for 5-sided machining, or for the safe and quick clamping of workpieces with ledges and different clamping heights on the machine table.

Advantage:

Simple, quick and flexible clamping of complex workpiece contours on the machine table. Especially suitable for levelling workpieces or clamping fixtures at the necessary machine heights in the machine tool and for the reliable clamping of same.

Note:

For the adaptation to zero point clamping modules, with the exception of the installation heights H20, 28 and 30, the mounting bore for the pull-studs, corresponding to sizes 10 and 20, is already made in the intermediate element.

If two or more intermediate elements are used, they can be axially aligned and then bolted using centring sleeves. The fastening bolts are supplied as standard.

When fastening to AMF grid plates, pay attention to bolt lengths!

Order numbers on the centring sleeves:

- size 10: Order no. 535732
- size 20: Order no. 78006

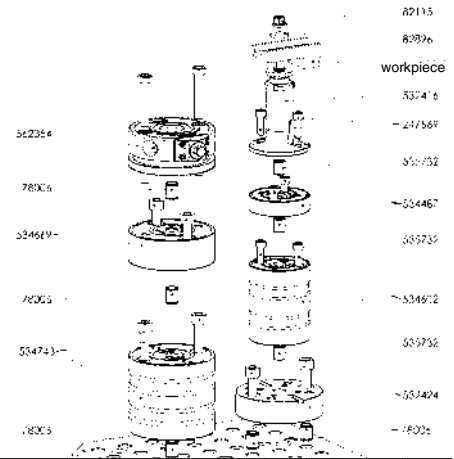

Dimensions:

Order no.	Size	dia. B1	dia. D	dia. D1 0/+0,01	dia. D2 F7	Screw DIN84 or ISO4762	E1	E2	G	R	S1
534487	B10	9	78	-	15	M8x30	5,0	13,0	M8	50	-
559683	B10	9	78	-	15	M8x30	5,0	13,0	M8	50	-
534503	B10	9	78	-	15	M8x30	5,0	13,0	M8	50	-
534529	B10	9	78	15	15	M8x30	5,0	13,0	M8	50	3,5
534545	B10	9	78	15	15	M8x45	5,0	13,0	M8	50	3,5
534560	B10	9	78	15	15	M8x50	5,0	13,0	M8	50	3,5
534586	B10	9	78	15	15	M8x50	5,0	13,0	M8	50	3,5
534602	B10	9	78	15	15	M8x50	5,0	13,0	M8	50	3,5
534628	B20	13	112	-	16	M12x25	9,0	9,0	M12	80	-
534644	B20	13	112	-	16	M12x25	11,5	11,25	M12	80	-
534669	B20	13	112	25	16	M12x25	11,5	11,25	M12	80	5,5
534685	B20	13	112	25	16	M12x55	11,5	11,25	M12	80	5,5
534701	B20	13	112	25	16	M12x55	11,5	11,25	M12	80	5,5
534727	B20	13	112	25	16	M12x55	11,5	11,25	M12	80	5,5
534743	B20	13	112	25	16	M12x55	11,5	11,25	M12	80	5,5

Subject to technical alterations.

No. 6210IZ

Intermediate element, with indexing

Tempered steel, plasma-nitrided and burnished.



height 20, 28 and 30 mm

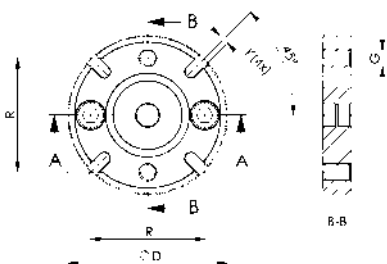
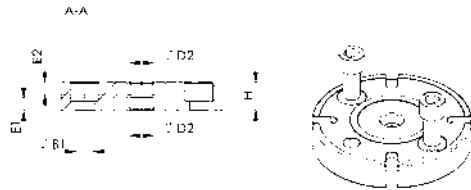

from height 40 mm

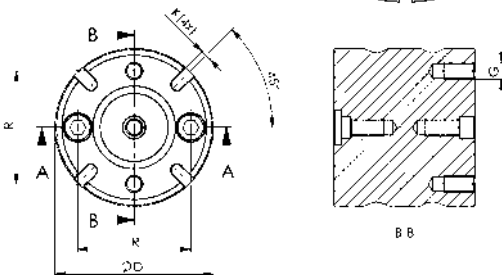
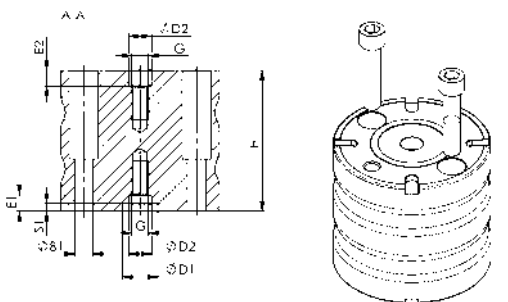

Order no.	Size	H ±0.01	Weight [g]
531996	B10	20	632
559684	B10	28	940
532010	B10	30	987
532036	B10	40	1327
532051	B10	50	1651
532077	B10	60	2001
532093	B10	80	2713
532119	B10	100	3429
532135	B20	20	1361
532150	B20	30	2087
532176	B20	40	2788
532192	B20	50	3439
532218	B20	60	4165
532234	B20	80	5632
532242	B20	100	6980

Application:

The intermediate elements with indexing are used as height adapters for workpieces and clamping fixtures, and are mounted to the main elements. Workpieces are clamped by means of assembly elements.

This clamping system can be used to move workpieces to the required machining height in the machine for 5-sided machining, or for the safe and quick clamping of workpieces with ledges and different clamping heights on the machine table.

Thanks to the 4-point 90° indexing option, workpieces under strong machining forces can be secured to prevent radial distortion.

Advantage:

Simple, quick and flexible clamping of complex workpiece contours on the machine table. Especially suitable for levelling workpieces or clamping fixtures at the necessary machine heights in the machine tool and for the reliable clamping of same.

Note:

For the adaptation to zero point clamping modules, with the exception of the installation heights H20, 28 and 30, the mounting bore for the pull-studs, corresponding to sizes 10 and 20, is already made in the intermediate element.

If two or more intermediate elements are used, they can be axially aligned and then bolted using centring sleeves. The fastening bolts are supplied as standard.

When fastening to AMF grid plates, pay attention to bolt lengths!

Order numbers of the centring sleeves:

- size 10: Order no. 535732

- size 20: Order no. 78006

Order number for the T-nuts: 430264

Dimensions:

Order no.	Size	dia. B1	dia. D	dia. D1 0/+0,01	dia. D2 F7	Screw DIN84 or ISO4762	E1	E2	G	K F6	R	S1
531996	B10	9	78	-	15	M8x30	5,0	13,0	M8	8	50	-
559684	B10	9	78	-	15	M8x30	5,0	13,0	M8	8	50	-
532010	B10	9	78	-	15	M8x30	5,0	13,0	M8	8	50	-
532036	B10	9	78	15	15	M8x30	5,0	13,0	M8	8	50	3,5
532051	B10	9	78	15	15	M8x45	5,0	13,0	M8	8	50	3,5
532077	B10	9	78	15	15	M8x50	5,0	13,0	M8	8	50	3,5
532093	B10	9	78	15	15	M8x50	5,0	13,0	M8	8	50	3,5
532119	B10	9	78	15	15	M8x50	5,0	13,0	M8	8	50	3,5
532135	B20	13	112	-	16	M12x25	9,0	9,0	M12	8	80	-
532150	B20	13	112	-	16	M12x25	11,5	11,25	M12	8	80	-
532176	B20	13	112	25	16	M12x25	11,5	11,25	M12	8	80	5,5
532192	B20	13	112	25	16	M12x55	11,5	11,25	M12	8	80	5,5
532218	B20	13	112	25	16	M12x55	11,5	11,25	M12	8	80	5,5
532234	B20	13	112	25	16	M12x55	11,5	11,25	M12	8	80	5,5
532242	B20	13	112	25	16	M12x55	11,5	11,25	M12	8	80	5,5

Subject to technical alterations.

No. 6210IFR

Base element, with indexing for grid plates

Tempered steel, plasma-nitrided and burnished.

Order no.	Size	H ±0.01	Weight [g]
532424	M12	30	2018
532440	M16	40	3881

Application:

The main element with indexing is positioned on grid plates M12 and M16 via a centering sleeve and then bolted. Intermediate elements or assembly elements can be adapted.

This clamping system can be used to move workpieces to the required machining height in the machine for 5-sided machining, or for the safe and quick clamping of workpieces with ledges and different clamping heights on the machine table.

Advantage:

Simple, quick and flexible clamping of complex workpiece contours on the machine table. Especially suitable for levelling workpieces or clamping fixtures at the necessary machine heights in the machine tool and for the reliable clamping of same.

Note:

Order numbers for the centering sleeves:

- Ø15: Order no. 535732
- Ø16: Order no. 78006
- Ø22: Order no. 78238



Dimensions:

Order no.	Size	dia. B1	dia. D	dia. D1	dia. D2 F7	dia. D3	E1	E2	E3	G	G1	K F6	R	R1	R2
532424	M12	13,5	112	16	16	15	9	11	14	M12	M8	8	80	80	50
532440	M16	17,5	133	22	16	15	13	11	14	M12	M8	8	100	80	50

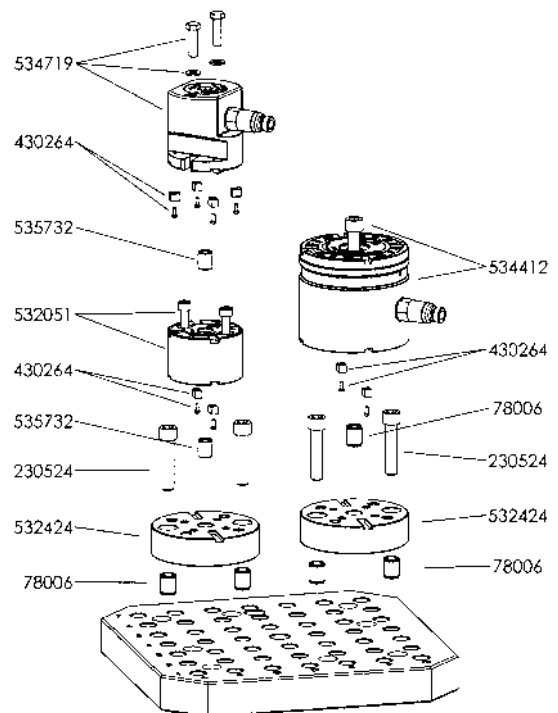
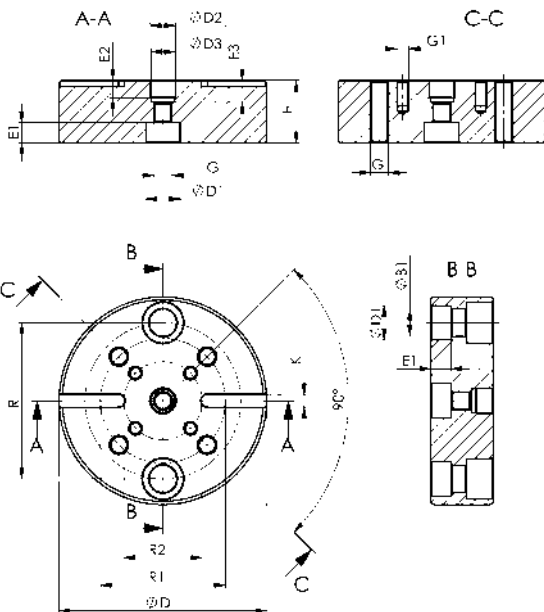

CAD

Subject to technical alterations.

No. 6210FNT

Base element, flat, for T-slot plate

Tempered steel, plasma-nitrided and burnished.

Order no.	Size	H ±0.01	Weight [g]
559097	B10	30	3861
559098	B20	30	6758

Application:

The main element can be freely positioned and fastened on the machine table with T-slots. Intermediate elements or assembly elements can be adapted. This clamping system can be used to move workpieces to the required machining height in the machine for 5-sided machining, or for the safe and quick clamping of workpieces with ledges and different clamping heights on the machine table with T-slots.

Advantage:

Through arrangement of the mounting slots, simple, quick and flexible clamping of complex workpiece contours on the machine table is possible with T-slots. Particularly suitable for levelling workpieces or clamping fixtures at the necessary machining heights in the machine tool and clamping these securely.

Note:

- Centring sleeves:
 - Ø15: order no. 535732
 - Ø16: order no. 78006



CAD



Dimensions:

Order no.	Size	A	A1	B1	B2	dia. D1	dia. D2 F7	E1	G	H1	L	R
559097	B10	136,5	100,5	13	17	79	15	13	M8	25	215,5	50
559098	B20	184,5	138,5	17	20	113	16	11	M12	25	259,5	80

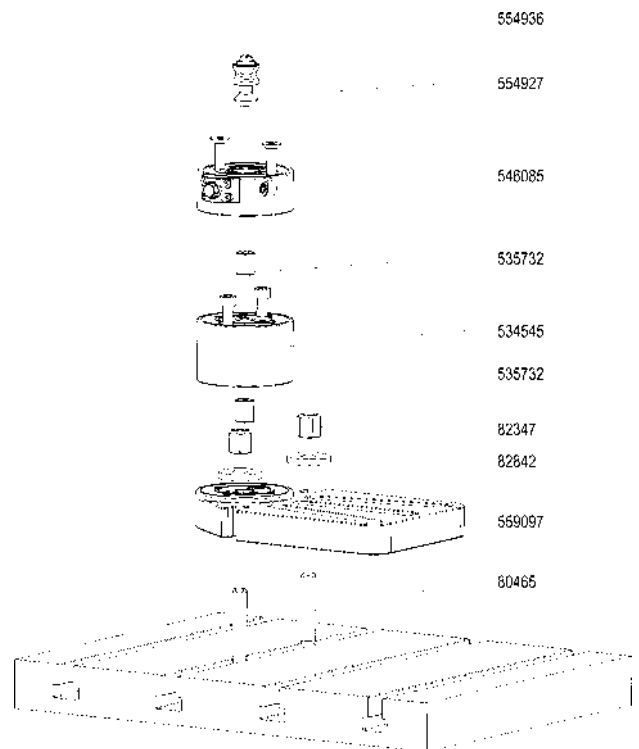
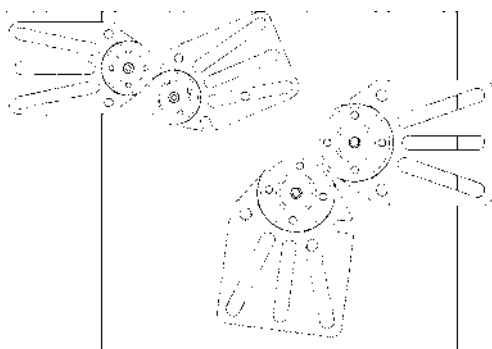
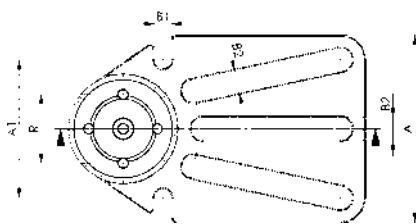
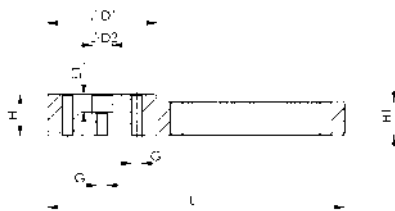

Subject to technical alterations.

No. 6210FN

Base element, round, for T-slot plate

Tempered steel, plasma-nitrided and burnished.

Order no.	Size	H ±0.01	Weight [g]
559095	B10	30	1554
559096	B20	30	3080

Application:

The main element can be freely positioned and fastened on the machine table with T-slots at the circumferential clamping rim. Intermediate elements or assembly elements can be adapted. This clamping system can be used to move workpieces to the required machining height in the machine for 5-sided machining, or for the safe and quick clamping of workpieces with ledges and different clamping heights on the machine table with T-slots.

Advantage:

Simple, quick and flexible clamping of complex workpiece contours on the machine table. Especially suitable for levelling workpieces or clamping fixtures at the necessary machine heights in the machine tool and for the reliable clamping of same.

Note:

Centring sleeves:

- Ø15: order no. 535732
- Ø16: order no. 78006

Spring washer

- order no. B10 = 559140
- order no. B20 = 535757.

T-nut no. 6322A with cylinder screws

ISO 4762-M6x10 can be used for positioning on a T-slot plate.



Dimensions:

Order no.	Size	dia. B1	dia. B2	B3	dia. D	dia. D1	ØD1 F7	E1	G	G1	H1	H2	dia. LK	R	R1
559095	B10	11,0	11,5	75	125	78	15	13,5	5 x M8	2 x M6	15	8	102	50	40
559096	B20	13,5	13,0	95	166	112	16	11,5	5 x M12	2 x M6	15	10	140	80	53

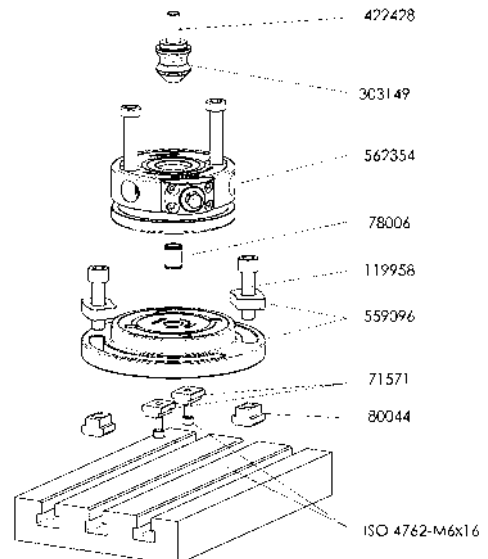
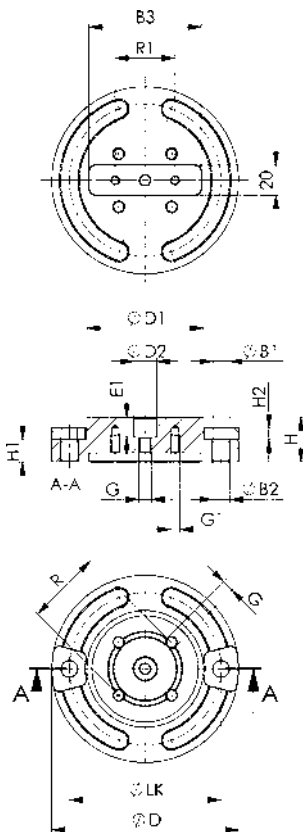

CAD



Subject to technical alterations.

No. 6210FN-10-2

Spring washer for base element, round

Tempered steel, hardened and burnished.

Order no.	Size	dia. B1	H2	L	L1	Weight [g]
559140	B10	11,0	8	22,5	30,5	31
535757	B20	13,5	10	26,0	41,0	62

Application:

The spring washer is used to securely fasten the base element for T-slot plates with cylinder-head screws onto the machine table.

Note:

Order no. 559140 suitable for base element, round order no. 559095,
order no. 535757 suitable for base element, round order no. 559096.

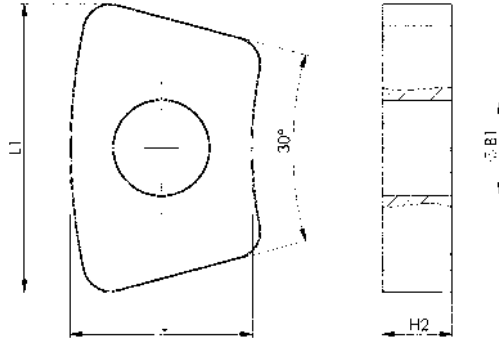

No. 6210A-20-10

Adapter reduction from KH20, KP20, KP10.3 to B10

Tempered steel, plasma-nitrided and burnished.

Order no.	Size	H ±0.01	Weight [g]
534750	B10	50	2923

Application:

The adapter element is used to reduce module sizes KH20, KP20 and KP10.3 to an intermediate element size B10. Intermediate elements or assembly elements can be adapted. This clamping system can be used to move workpieces to the required machining height in the machine for 5-sided machining, or for the safe and quick clamping of workpieces with ledges and different clamping heights on the machine table.

Advantage:

Simple, quick and flexible clamping of complex workpiece contours on the machine table. Especially suitable for levelling workpieces or clamping fixtures at the necessary machine heights in the machine tool and for the reliable clamping of same.

Note:

Order numbers for the centering sleeves:

- Ø15: Order no. 535732
- Ø16: Order no. 78006
- Ø22: Order no. 78238

The fastening screws are supplied as standard.

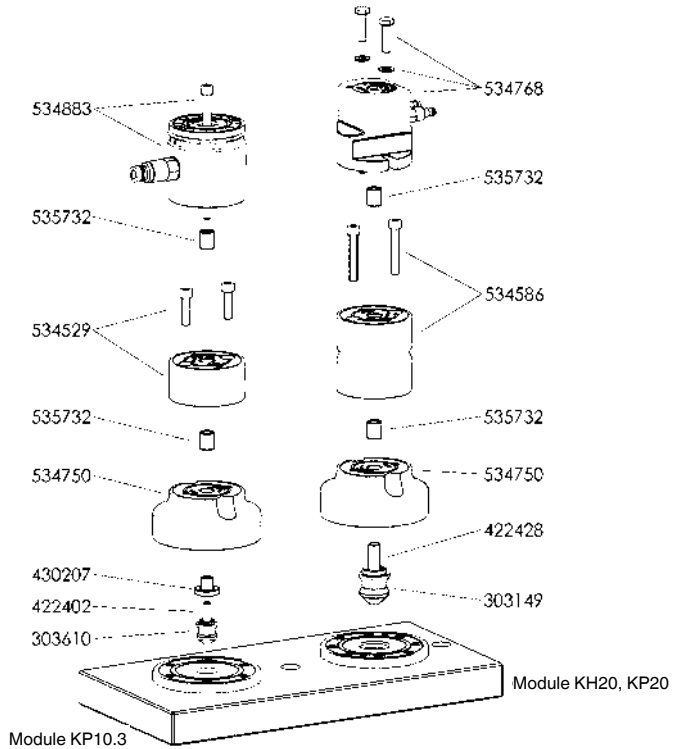
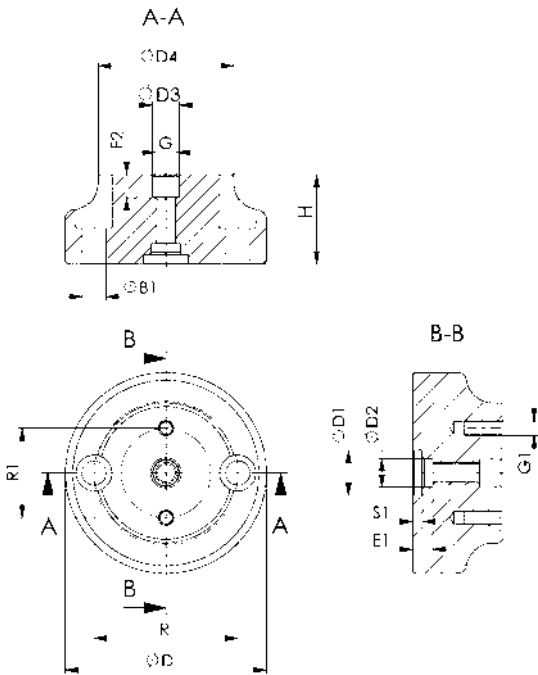

Dimensions:

Order no.	Size	dia. B1	dia. D	dia. D1 0/+0.01	dia. D2 F7	dia. D3	dia. D4	Screw DIN84 or ISO4762	E1	E2	G	G1	R	R1	S1
534750	B10	13,5	112	25	16	15	78	M12x50	11,5	13	M12	M8	80	50	5,5

Subject to technical alterations.

No. 6210IA-20-10

Adapter reduction from KH20, KP20, KP10.3 to K10, with indexing

Tempered steel, plasma-nitrided and burnished.

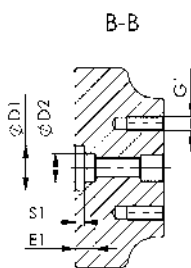
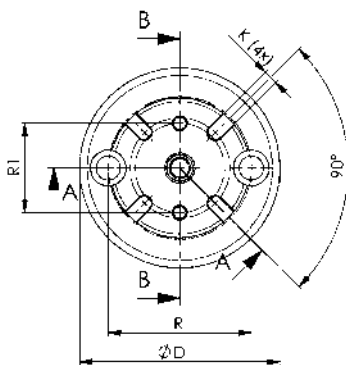
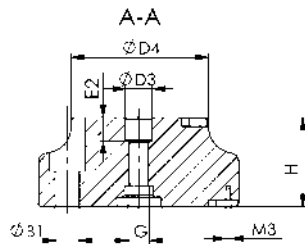
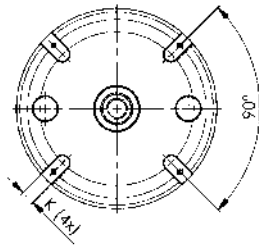

Application:

The adapter element is used to reduce module sizes KH20, KP20 and KP10.3 to an intermediate element size B10. Intermediate elements or assembly elements can be adapted. This clamping system can be used to move workpieces to the required machining height in the machine for 5-sided machining, or for the safe and quick clamping of workpieces with ledges and different clamping heights on the machine table. Thanks to the 4-point 90° indexing option, workpieces under strong machining forces can be secured to prevent radial distortion.

Advantage:

Simple, quick and flexible clamping of complex workpiece contours on the machine table. Especially suitable for levelling workpieces or clamping fixtures at the necessary machine heights in the machine tool and for the reliable clamping of same.

Note:

Order numbers for the centering sleeves:

- Ø15: Order no. 535732
- Ø16: Order no. 78006
- Ø22: Order no. 78238

Slot nuts: Order no. 430264.

The fastening screws are supplied as standard.



Dimensions:

Order no.	Size	dia. B1	dia. D	dia. D1 0/+0,01	dia. D2 F7	dia. D3	dia. D4	Screw DIN84 or ISO4762	E1	E2	G	G1	K F6	R	R1	S1
532499	B10	13,5	112	25	16	15	78	M12x50	9	13	M12	M8	8	80	50	5,5

Subject to technical alterations.

No. 6209MZA

Adapter for height compensation

Tempered steel, plasma-nitrided.

Order no.	Size	H ±0.01	Weight [g]
558052	B10	20	753
558053	B20	30	2306

Application:

Adapter for installation of the height counterbalance element to an intermediate or base element.

Advantage:

Simple, quick and flexible clamping of complex workpiece contours on the machine table. Particularly suitable for levelling workpieces or clamping fixtures at the necessary machine heights in the machine tool for clamping these securely.

Note:

The adapter can be aligned axially on the intermediate or base element using the centring sleeve and then bolted on.

The fastening bolts are supplied as standard.

Order numbers of the centring sleeves:

- size B10: order no. 535732 and 430223

- size B20: order no. 78006

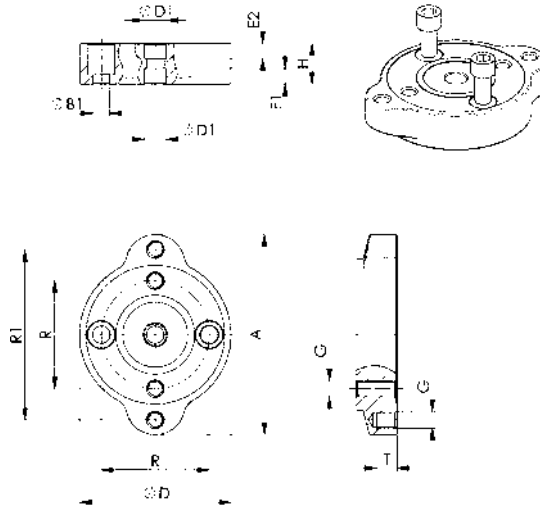

Dimensions:

Order no.	Size	A	dia. B1	dia. D	ØD1 F7	Screw DIN84 or ISO4762	E1	E2	G	R	R1	T
558052	B10	105	9	78	15	M8x30	5,0	13,00	M8	50	88	11
558053	B20	148	13	112	16	M12x25	11,5	11,25	M12	80	126	15

CAD



Subject to technical alterations.

No. 6212MA-20-10

Adapter for clamping module, mechanical

Tempered steel, plasma-nitrided and burnished.

Order no.	Size	H ±0.01	Weight [Kg]
561993	B10	40	1,3

Application:

Adapter for installation of the mechanical clamping module 6212M size BM20 (559094) to an intermediate or base element size B10.

Advantage:

Simple, quick and flexible clamping of complex workpiece contours on the machine table. Particularly suitable for levelling workpieces or clamping fixtures at the necessary machining heights in the machine tool and clamping these securely.

Note:

The adapter can be aligned axially on the intermediate or base element using the centring sleeve and then bolted on.

The fastening bolts are supplied as standard.

Order numbers of the centring sleeves:

- size B10: order no. 535732

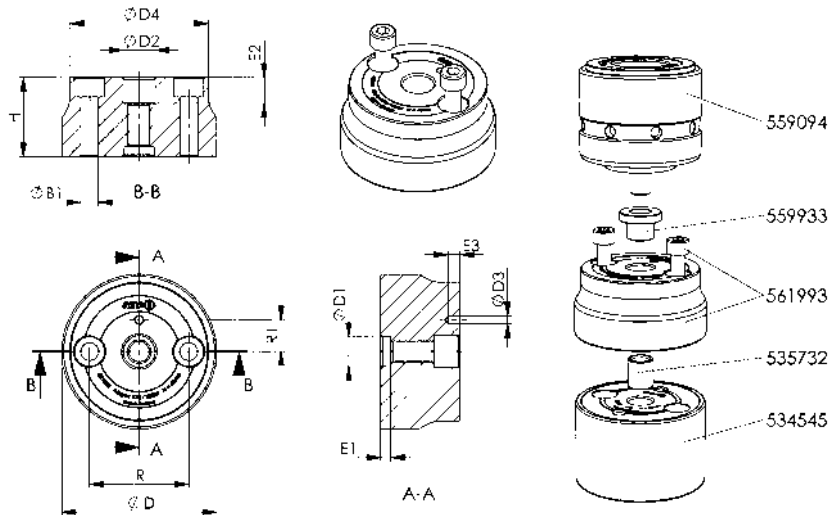

Dimensions:

Order no.	Size	dia. B1	dia. D	ØD1 F7	dia. D2 F7	dia. D3	dia. D4	E1	E2	E3	R	R1
561993	B10	9	78	15	16	4,2	70	5	13	6	50	16



No. 6363-**-005

Centring sleeve, cylindrical

Order no.	Size	dia. D	G	L-0.2	dia. S	Weight [g]
78006	12	16 +0,011/0	R1/4	20,5	12,5	9
78238	16	22 +0,015/+0,002	M18	16,5	25	

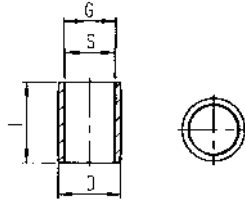

No. 6210-15-01

Centering sleeve Ø 15

Order no.	Size	dia. D	G	L-0.2	dia. S	Weight [g]
535732	15	15 +0,011/0	M12	17,4	10,1	12

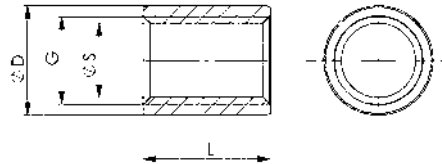

CAD



No. 6210-XX

Centring pin

Order no.	dia. D	dia. D1	dia. D2	L	L1	Weight [g]
550198	22	15	8,5	20	14	28
559933	25	16	12,5	16	11	21
550197	32	16	12,5	18	11	36



Application:

To position the double clamping modules on a clamping plate with clearance holes or a foot element from the „Modular height adapter“ AMF clamping system.

Advantage:

Highly-precise positioning of the double clamping module.

Note:

The centring pin is used when the double clamping module is not yet positioned with a pull-stud for T-slot and can be clamped.

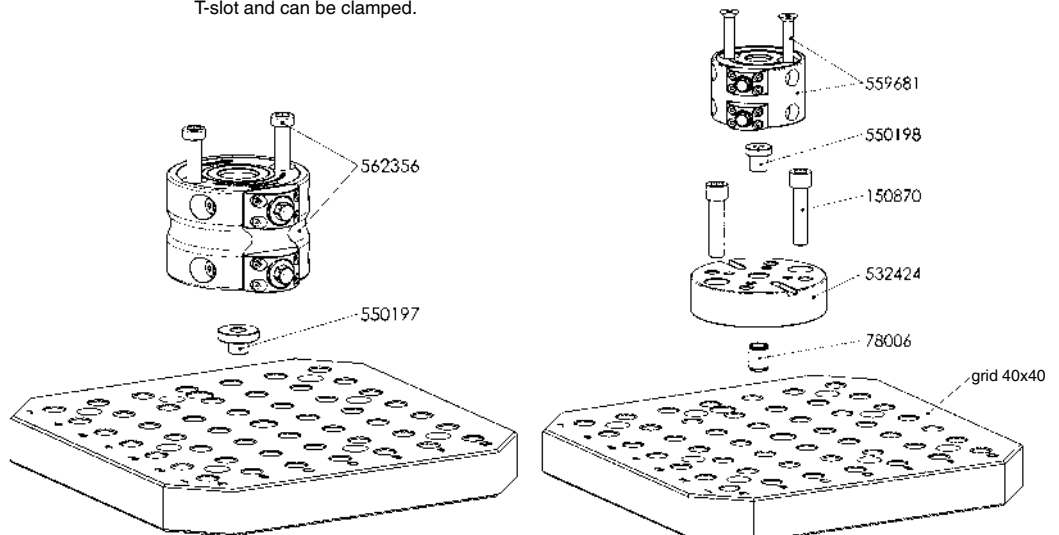
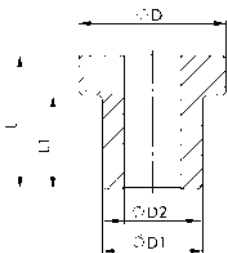

CAD



Subject to technical alterations.



CAD

VARIABLE CENTRE DISTANCE - THE SIMPLEST SOLUTION FOR FLEXIBLE MANUFACTURING

Looking for a simple, flexible and modular clamping solution that satisfies your requirements for a modern, cost-efficient and cost-optimised manufacturing process?

This is guaranteed by the immensely varied AMF zero point clamping system „Zero-Point“.

The manufacture of prototypes, small batch series and testing and measuring fixtures used to be a challenging field of application. Flexibility was to some degree limited by a fixed depth gauge.

The variable depth gauge recently developed by AMF has eliminated these boundaries. A simple displacement of the clamping modules enables the depth gauges to be quickly adapted to your specific needs.

This additional flexibility drastically cuts your tooling costs and machine downtimes, not only for medium and large batch series, but also for prototypes and small batch series, as well as test devices.



- > Clamping brackets for direct workpiece clamping in simple 5-sided machining
- > Variable depth gauge by easily displacing the clamping modules on a grooved or grid plate
- > Easy to adapt various module sizes to suit the application at hand.
- > Five standard thread sizes for the pull-studs in the workpiece to choose from - M5, M6, M8, M12, M16
- > Use of threaded adapter sleeves enables the pull-studs to be mounted in any size of locating bores in the workpiece.
- > Direct workpiece clamping can be realised by the simplest of means
- > Prototypes, small batch series, test and measuring devices, installation devices can be clamped using the AMF-Zero-Point-System in a manner that fulfills your future needs.

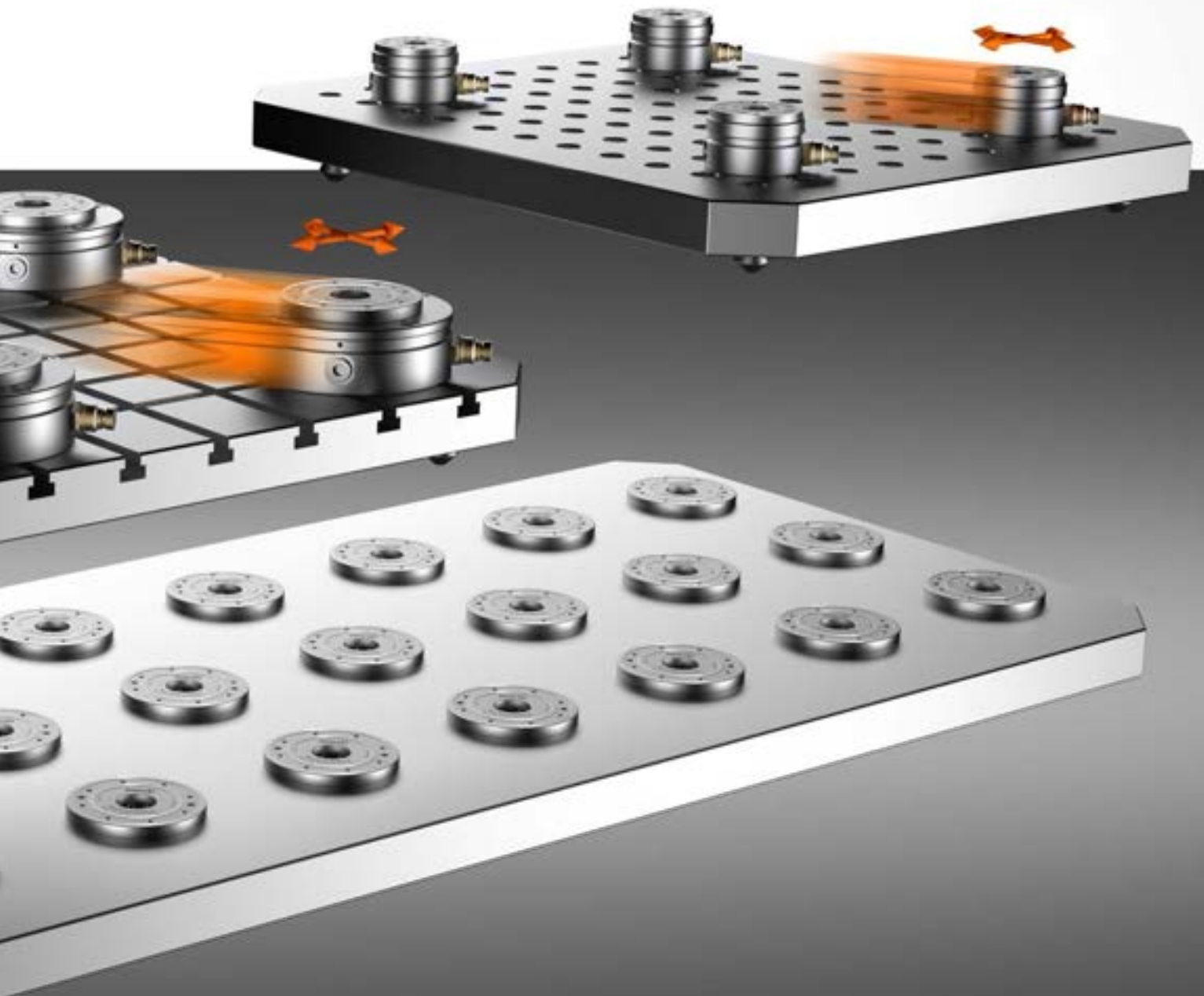

FLEXIBLE SYSTEM - THE ZERO-POINT-SYSTEM ADAPTS PERFECTLY TO YOUR REQUIREMENTS

- > Differing AMF clamping modules from $\varnothing 22$ to $\varnothing 148$ mm can be used in combination.
- > Smallest depth gauges from 23 mm are realised simply, flexibly and quickly.
- > Thanks to the innumerable possible combinations between differently sized clamping modules and pull studs, direct workpiece clamping is straightforward and specific.

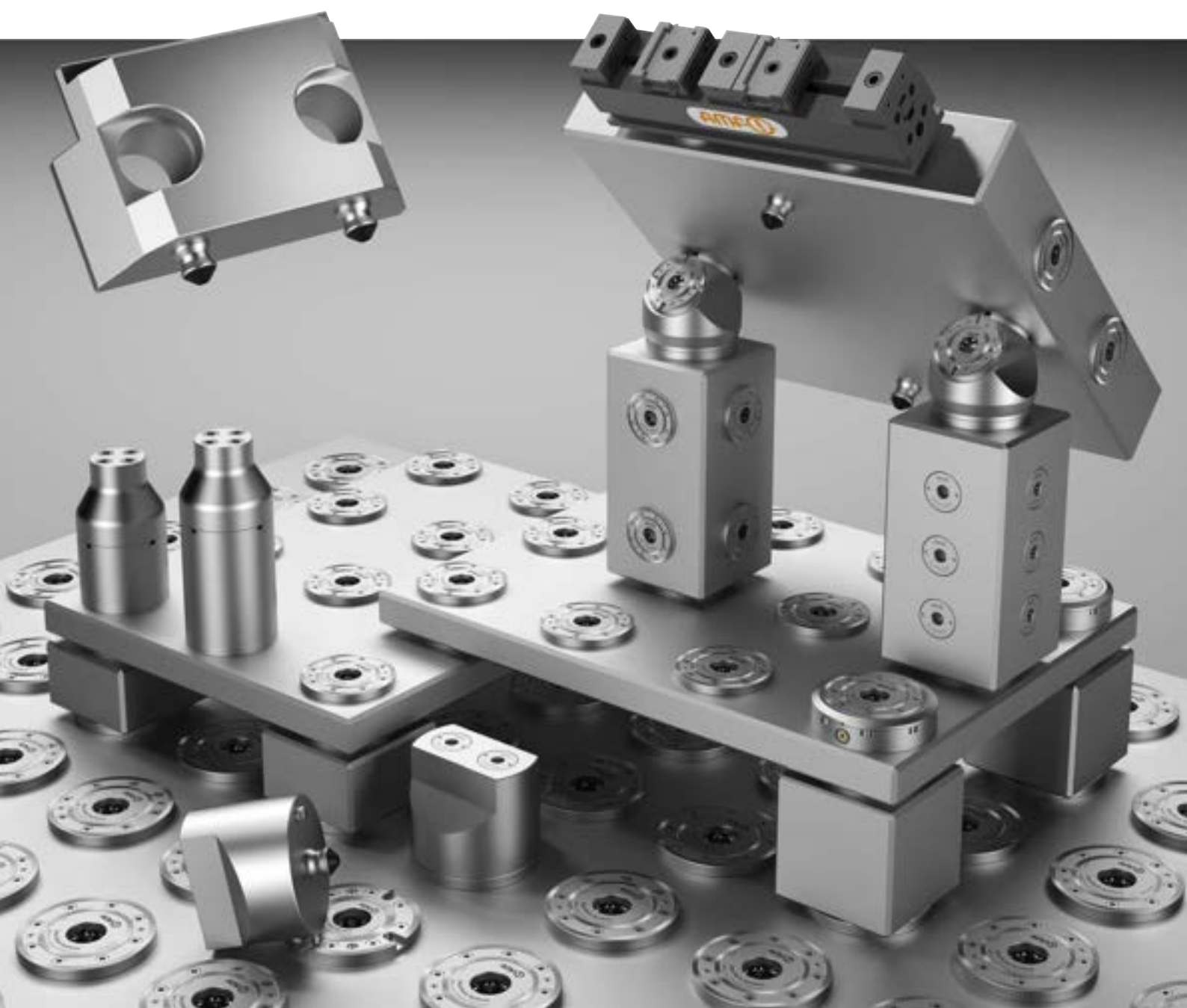

No. 6203S4L-150

4-point clamping station

Main body: Aluminium, anodised.
Repeat accuracy < 0.02 mm.



Order no.	Size	Pull-in/locking force up to	Holding force*	Weight
		[N]	[N]	
533034	SP150	4 x 235	4 x 6000	2400

Design:

Pneumatic 4-point clamping station with air gun valve for quick opening and closing via air gun. The clamping station has two clamping slots on the side for fastening to the machine table. In addition, positioning slots for aligning on the machine table are made on the underside. The holder for a pull-stud is also provided in the 150 version.

Note:

* Please observe the installation instructions.

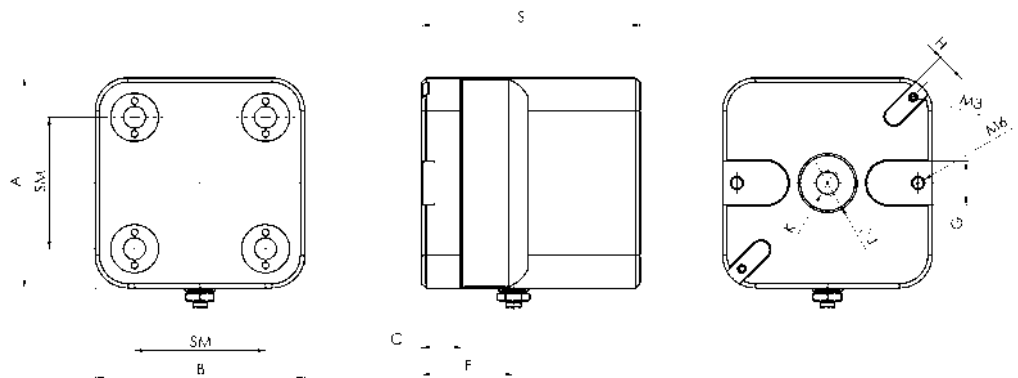

Dimensions:

Order no.	Size	A	B	C	F	G	H	dia. J	K	S	SM
533034	SP150	96	96	15	42	20	8	25	M12	100	60

No. 6203PS4-150

Interchangeable pallet

High-strength aluminium, anodised.



Order no.	Size	A	B	S	SM	Weight
						[g]
533059	150	98	98	20	60	530

Design:

Interchangeable pallet for 4-point clamping station SP150 with 4 pull-studs.

Note:

On request, we can incorporate mounting holes according to your specifications in the change pallet.

On request:

Other dimensions, pitch spacings and number of equipped pull-studs.

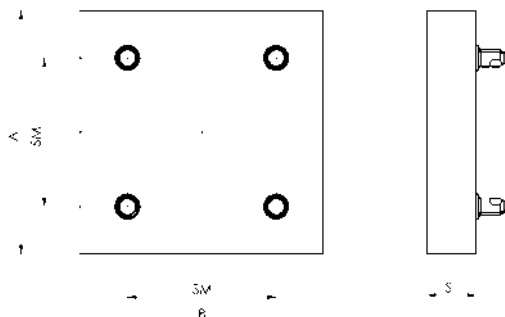

REPRESENTS GOOD VALUE FROM THE GROUND UP

- THE KH10.2 CLAMPING MODULE

Zero-point clamping does not have to be expensive. With the KH10.2 clamping module we offer you the best technology at a favourable price.

The advantages speak for themselves:

- > Outstanding price-performance ratio
- > Drastically reduced tooling time
- > Immediate improvement of productivity
- > Repeat accuracy < 5µm
- > Stainless steel
- > Form fit
- > Fitting depth of only 22 mm!





**6 COMPONENTS FOR PERFECT CLAMPING -
5 BAR COMPRESSED AIR FOR OPENING WITH
THE AIR HYDRAULIC PUMP**

- 1** Absolutely insensitive to lateral and pull forces that arise. Precision ground support surfaces made of hardened stainless steel for plane-parallel clamping ≤ 0.005 mm.
 - 2** Hardened piston - the combination of form fit and self-locking results in reliable and constant clamping.
 - 3** Precision balls for optimal power transmission as well as vibration-inhibiting and wear-resistant use.
 - 4** Ball support made of stainless steel seals the clamping module against dirt and liquids.
 - 5** Robust plate springs for maximum pull-in, closing and holding forces.
 - 6** Module floor with integrated air jet function.
- A** The low installation depth of the clamping modules of 22 mm permits a height of the base plate of only 28 mm (without blow out, only 24 mm).

No. 6204S2HA-001

2-point clamping station

Hydraulic unlocking.
Pneumatic blow-out.
Opening operating pressure: min. 50 bar - max. 60 bar.
Clamping modules' contact surface: Steel, stainless and hardened.
Base plate: Steel, unhardened.
Repetition accuracy < 0.005 mm.

Order no.	Size	Pull-in/locking force up to [kN]	Holding force* [kN]	Blow out	Weight [Kg]
427484	KH10.2	2 x 10	2 x 25	●	14

Design:

Hydraulic clamping station for optimised clamping times on machine tables with distance between slots of 63, 100 and 125 mm. Clamping is with M12 socket head screws. At least two fitting holes are attached for alignment.
The insertion dimension of the clamping modules is 200 mm. The quick coupling plug is pre-mounted, and the integrated blow-out function can be individually connected.

Advantage:

Low overall height of only 36 mm.

Note:

* Please observe the installation instructions.

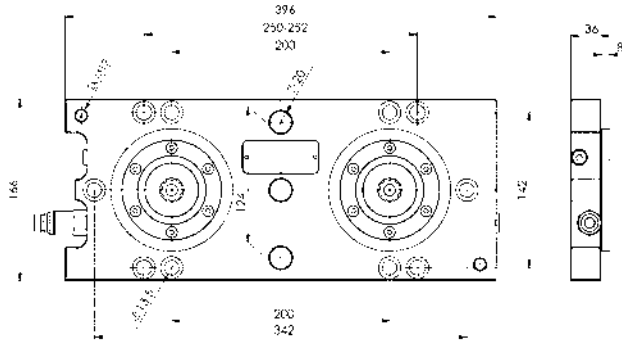
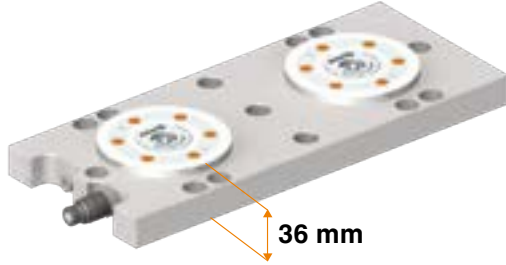

CAD



No. 6204S4HA-001

4-point clamping station

Hydraulic unlocking.
Pneumatic blow-out.
Opening operating pressure: min. 50 bar - max. 60 bar.
Clamping modules' contact surface: Steel, stainless and hardened.
Base plate: Steel, unhardened.
Repetition accuracy < 0.005 mm.

Order no.	Size	Pull-in/locking force up to [kN]	Holding force* [kN]	Blow out	Weight [Kg]
427500	KH10.2	4 x 10	4 x 25	●	30

Design:

Hydraulic clamping station for optimised clamping times on machine tables with distance between slots of 63, 100 and 125 mm. Clamping is with M12 socket head screws. At least two fitting holes are attached for alignment.
The insertion dimension of the clamping modules is 200 mm. The quick coupling plug is pre-mounted, and the integrated blow-out function can be individually connected.

Advantage:

Low overall height of only 36 mm.

Note:

* Please observe the installation instructions.

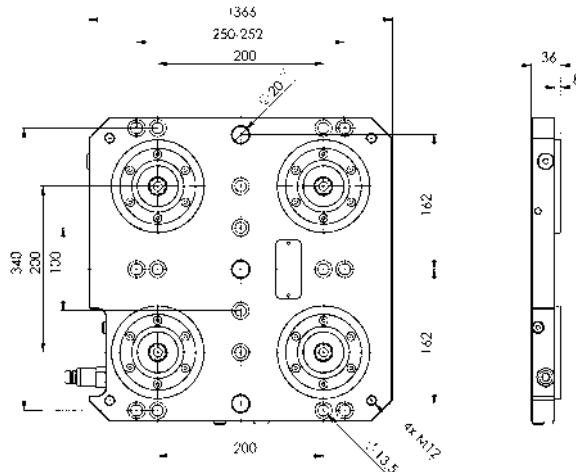
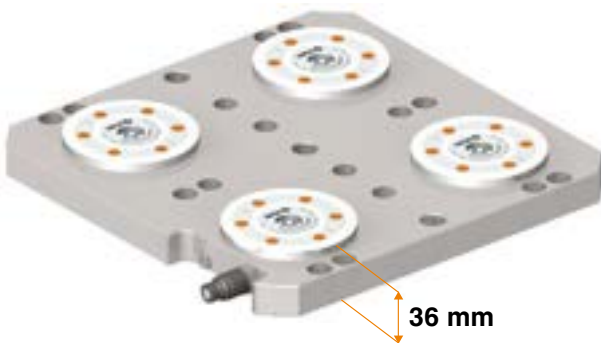

CAD



Subject to technical alterations.

No. 6204S6HA-001

6-point clamping station

Hydraulic unlocking.

Pneumatic blow-out.

Opening operating pressure: min. 50 bar - max. 60 bar.

Clamping modules' contact surface: Steel, stainless and hardened.

Base plate: Steel, unhardened.

Repetition accuracy < 0.005 mm.

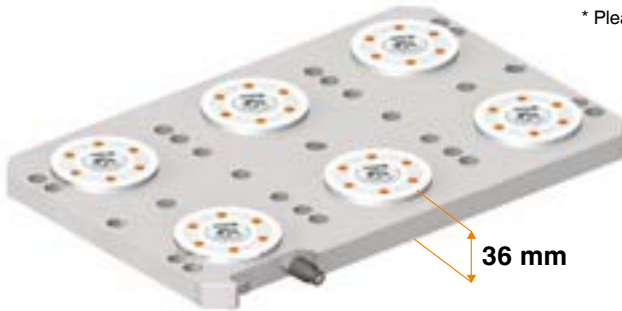

Order no.	Size	Pull-in/locking force up to [kN]	Holding force* [kN]	Blow out	Weight [Kg]
427526	KH10.2	6 x 10	6 x 25	●	46

Design:

Hydraulic clamping station for optimised clamping times on machine tables with distance between slots of 63, 100 and 125 mm. Clamping is with M12 socket head screws. At least two fitting holes are attached for alignment.

The insertion dimension of the clamping modules is 200 mm. The quick coupling plug is pre-mounted, and the integrated blow-out function can be individually connected.

Advantage:

Low overall height of only 36 mm.

Note:

* Please observe the installation instructions.

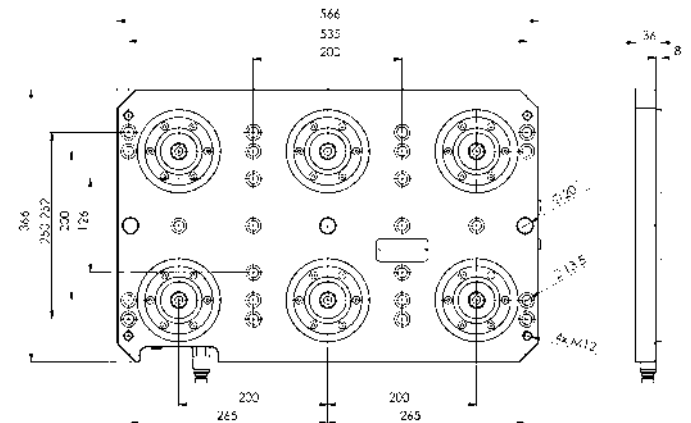

No. 6204S8HA-001

8-point clamping station

Hydraulic unlocking.

Pneumatic blow-out.

Opening operating pressure: min. 50 bar - max. 60 bar.

Clamping modules' contact surface: Steel, stainless and hardened.

Base plate: Steel, unhardened.

Repetition accuracy < 0.005 mm.

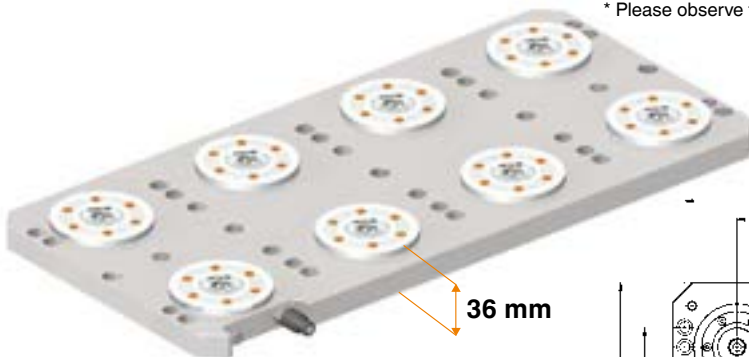

Order no.	Size	Pull-in/locking force up to [kN]	Holding force* [kN]	Blow out	Weight [Kg]
427542	KH10.2	8 x 10	8 x 25	●	63

Design:

Hydraulic clamping station for optimised clamping times on machine tables with distance between slots of 63, 100 and 125 mm. Clamping is with M12 socket head screws. At least two fitting holes are attached for alignment.

The insertion dimension of the clamping modules is 200 mm. The quick coupling plug is pre-mounted, and the integrated blow-out function can be individually connected.

Advantage:

Low overall height of only 36 mm.

Note:

* Please observe the installation instructions.

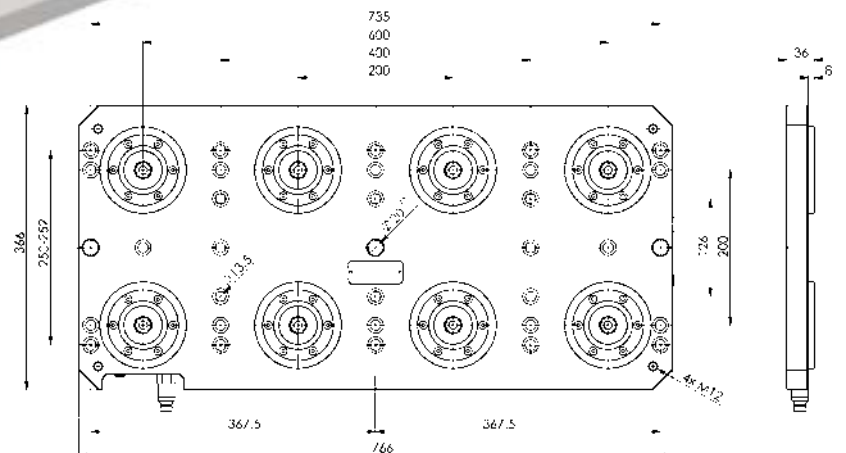

Subject to technical alterations.

No. 6204S4HA-002

4-point clamping station

Hydraulic unlocking.
Pneumatic blow-out.
Opening operating pressure: min. 50 bar - max. 60 bar.
Clamping modules' contact surface: Steel, stainless and hardened.
Base plate: Steel, unhardened.
Repetition accuracy < 0.005 mm.

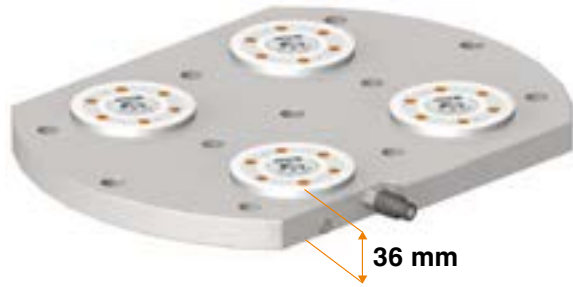

Order no.	Size	Pull-in/locking force up to [kN]	Holding force* [kN]	Blow out	Weight [Kg]
427492	KH10.2	4 x 10	4 x 25	●	37

Design:

Hydraulic clamping station for optimised clamping times on machine tables with distance between slots of 63 mm. Clamping is with M12 socket head screws. At least two fitting holes are attached for alignment.
The insertion dimension of the clamping modules is 200 mm. The quick coupling plug is pre-mounted, and the integrated blow-out function can be individually connected.

Application:

e.g. for DMG / DMU 50 EVO

Advantage:

Low overall height of only 36 mm.

Note:

* Please observe the installation instructions.

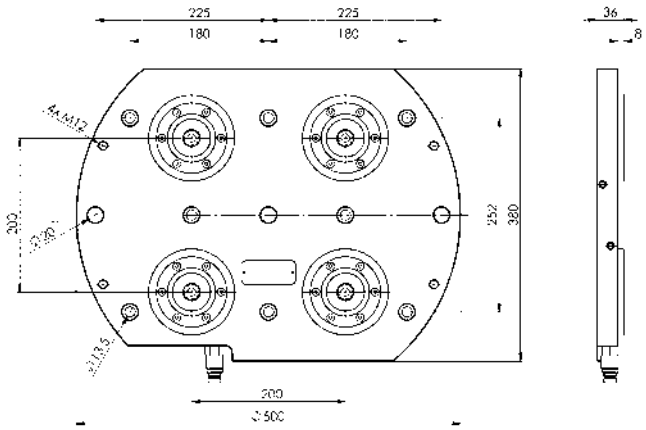

No. 6204S4HA-003

4-point clamping station

Hydraulic unlocking.
Pneumatic blow-out.
Opening operating pressure: min. 50 bar - max. 60 bar.
Clamping modules' contact surface: Steel, stainless and hardened.
Base plate: Steel, unhardened.
Repetition accuracy < 0.005 mm.

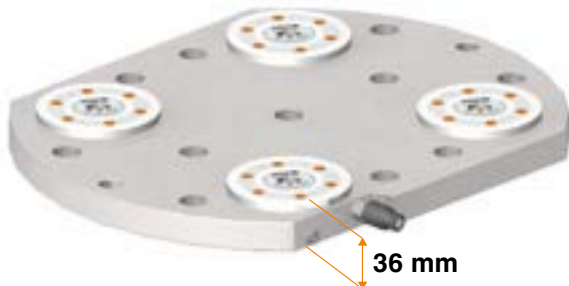

Order no.	Size	Pull-in/locking force up to [kN]	Holding force* [kN]	Blow out	Weight [Kg]
427518	KH10.2	4 x 10	4 x 25	●	38

Design:

Hydraulic clamping station for optimised clamping times on machine tables with distance between slots of 80 mm. Clamping is with M16 socket head screws. At least two fitting holes are attached for alignment.
The insertion dimension of the clamping modules is 240 mm. The quick coupling plug is pre-mounted, and the integrated blow-out function can be individually connected.

Application:

e.g. for Mazak Variaxis 500

Advantage:

Low overall height of only 36 mm.

Note:

* Please observe the installation instructions.

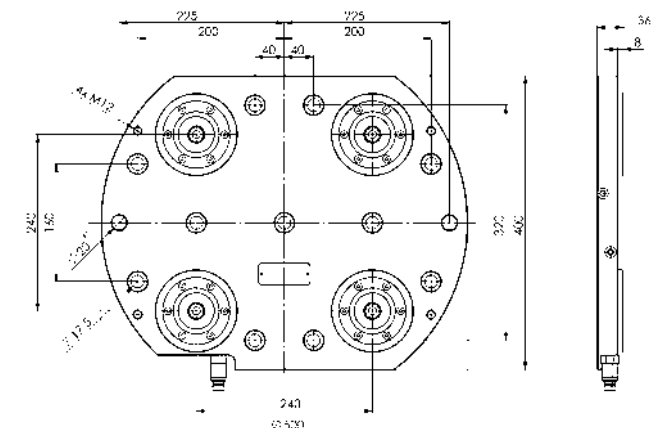

Subject to technical alterations.

No. 6204S6HA-002

6-point clamping station

Hydraulic unlocking.
 Pneumatic blow-out.
 Opening operating pressure: min. 50 bar - max. 60 bar.
 Clamping modules' contact surface: Steel, stainless and hardened.
 Base plate: Steel, unhardened.
 Repetition accuracy < 0.005 mm.



Order no.	Size	Pull-in/locking force up to [kN]	Holding force* [kN]	Blow out	Weight [Kg]
427534	KH10.2	6 x 10	6 x 25	●	62

Design:

Hydraulic clamping station for optimised clamping times on machine tables with distance between slots of 63 mm. Clamping is with M12 socket head screws. At least two fitting holes are attached for alignment.
 The insertion dimension of the clamping modules is 200 mm. The quick coupling plug is pre-mounted, and the integrated blow-out function can be individually connected.

Application:

e.g. for DMG / DMU 50

Advantage:

Low overall height of only 36 mm.

Note:

* Please observe the installation instructions.

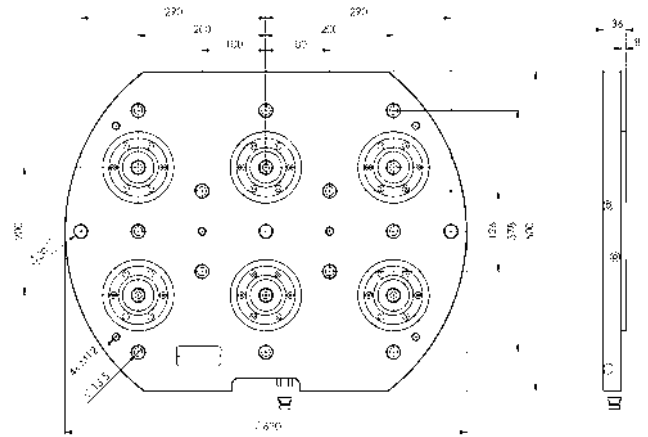

No. 6204S6HA-003

6-point clamping station

Hydraulic unlocking.
 Pneumatic blow-out.
 Opening operating pressure: min. 50 bar - max. 60 bar.
 Clamping modules' contact surface: Steel, stainless and hardened.
 Base plate: Steel, unhardened.
 Repetition accuracy < 0.005 mm.



Order no.	Size	Pull-in/locking force up to [kN]	Holding force* [kN]	Blow out	Weight [Kg]
427559	KH10.2	6 x 10	6 x 25	●	62

Design:

Hydraulic clamping station for optimised clamping times on machine tables with distance between slots of 100 mm. Clamping is with M16 socket head screws. At least two fitting holes are attached for alignment.
 The insertion dimension of the clamping modules is 200 mm. The quick coupling plug is pre-mounted, and the integrated blow-out function can be individually connected.

Application:

e.g. for Mazak Variaxis 630

Advantage:

Low overall height of only 36 mm.

Note:

* Please observe the installation instructions.

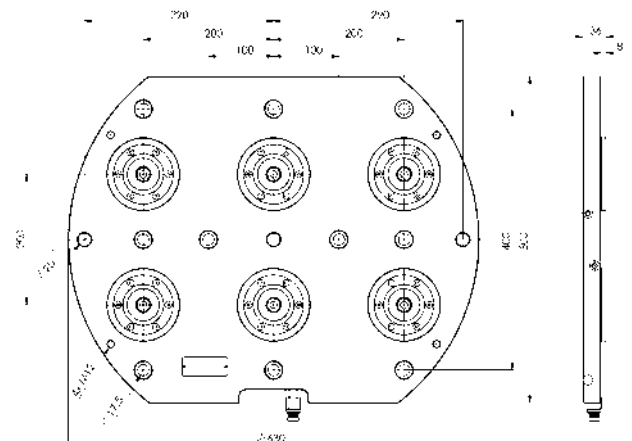

Subject to technical alterations.

No. 6204S6HA-004

6-point clamping station

Hydraulic unlocking.
Pneumatic blow-out.
Opening operating pressure: min. 50 bar - max. 60 bar.
Clamping modules' contact surface: Steel, stainless and hardened.
Base plate: Steel, unhardened.
Repetition accuracy < 0.005 mm.

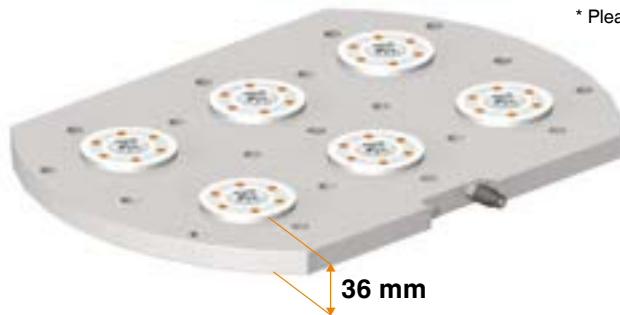

Order no.	Size	Pull-in/locking force up to [kN]	Holding force* [kN]	Blow out	Weight [Kg]
427567	KH10.2	6 x 10	6 x 25	●	62

Design:

Hydraulic clamping station for optimised clamping times on machine tables with distance between slots of 63 mm. Clamping is with M12 socket head screws. At least two fitting holes are attached for alignment.

The insertion dimension of the clamping modules is 200 mm. The quick coupling plug is pre-mounted, and the integrated blow-out function can be individually connected.

Application:

e.g. for DMG / DMU 70 EVO

Advantage:

Low overall height of only 36 mm.

Note:

* Please observe the installation instructions.

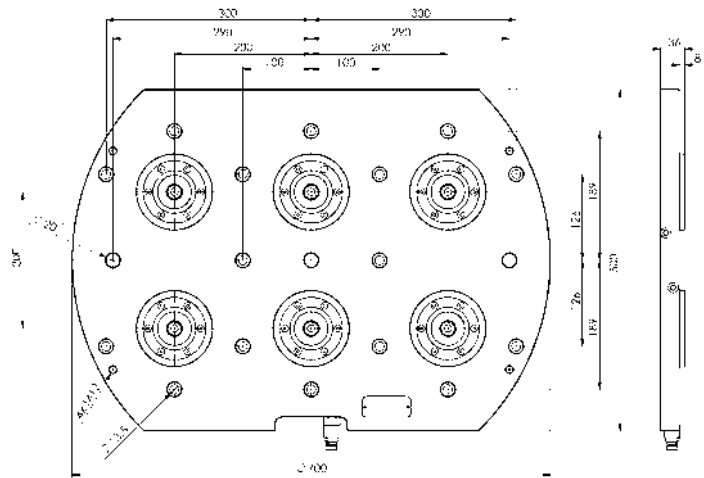

No. 6204K2HA-015

2-point clamping bracket

Hydraulic unlocking.
Pneumatic blow-out.
Opening operating pressure: min. 50 bar - max. 60 bar.
Clamping modules' contact surface: Steel, stainless and hardened.
Base plate: Steel, unhardened.
Repetition accuracy < 0.005 mm.



Order no.	Size	Pull-in/locking force up to [kN]	Holding force* [kN]	Blow out	Weight [Kg]
427591	KH10.2	2 x 10	2 x 25	●	31

Design:

Hydraulic clamping bracket for set-up-time-optimised clamping on KH10.2 clamping stations. Pull-studs installed underneath.

The pitch spacing of the clamping modules is 200 mm. The quick-coupling plug is pre-mounted, and the integrated blow-out function can be individually connected.

Note:

* Please observe the installation instructions.

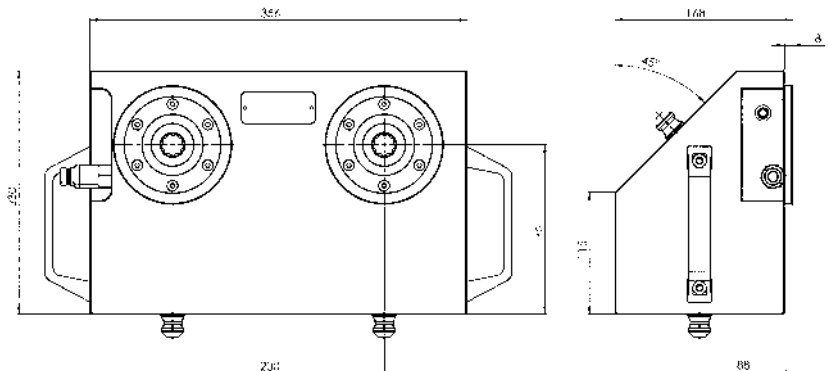

No. 6204K1HA-001

Single clamping bracket

Hydraulic unlocking.
 Pneumatic blow-out.
 Opening operating pressure: min. 50 bar - max. 60 bar.
 Clamping modules' contact surface: Steel, stainless and hardened.
 Base plate: Steel, unhardened.
 Repetition accuracy < 0.005 mm.



Order no.	Size	Pull-in/locking force up to [kN]	Holding force* [kN]	Blow out	S [mm]	Weight [Kg]
428060	KH10.2	10	25	●	150	32
428086	KH10.2	10	25	●	200	38
428102	KH10.2	10	25	●	240	42

Design:

Hydraulic clamping bracket for set-up-time-optimised clamping on KH10.2 clamping stations. Installation clamping module KH10.2 with quadruple indexing. Pull-studs installed underneath. The pitch spacing is 200 mm. The quick-coupling plug is pre-mounted, and the integrated blow-out function can be individually connected.

Note:

* Please observe the installation instructions.

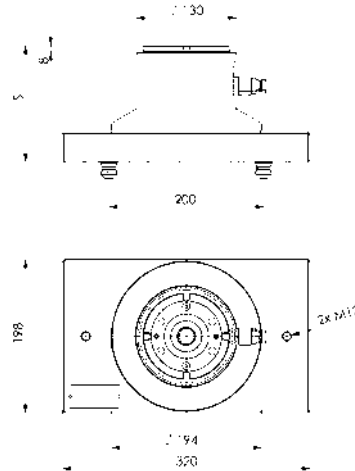

No. 6204K1HA-004

Single clamping bracket

Hydraulic unlocking.
 Pneumatic blow-out.
 Opening operating pressure: min. 50 bar - max. 60 bar.
 Clamping modules' contact surface: Steel, stainless and hardened.
 Base plate: Steel, unhardened.
 Repetition accuracy < 0.005 mm.



Order no.	Size	Pull-in/locking force up to [kN]	Holding force* [kN]	Blow out	S [mm]	Weight [Kg]
428128	KH10.2	10	25	●	150	45
428144	KH10.2	10	25	●	200	50
428169	KH10.2	10	25	●	240	54

Design:

Hydraulic clamping bracket for set-up-time-optimised clamping on KH10.2 clamping stations. Installation clamping module KH10.2 with quadruple indexing. Pull-studs installed underneath. The pitch spacing is 200 mm. The quick-coupling plug is pre-mounted, and the integrated blow-out function can be individually connected.

Note:

* Please observe the installation instructions.

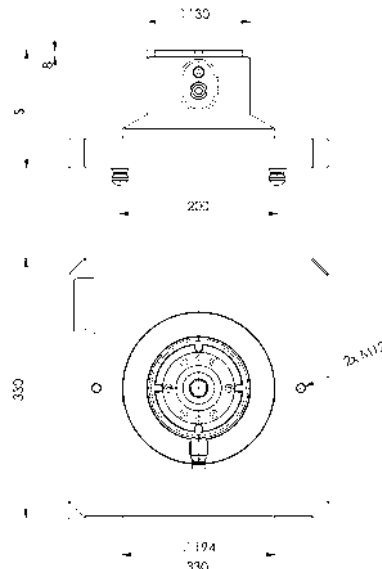

No. 6204K2HA-011

2-point clamping bracket

Hydraulic unlocking.
 Pneumatic blow-out.
 Opening operating pressure: min. 50 bar - max. 60 bar.
 Clamping modules' contact surface: Steel, stainless and hardened.
 Base plate: Steel, unhardened.
 Repetition accuracy < 0.005 mm.



Order no.	Size	Pull-in/locking force up to [kN]	Holding force* [kN]	Blow out	S [mm]	Weight [Kg]
427864	KH10.2	2 x 10	2 x 25	●	150	31
427880	KH10.2	2 x 10	2 x 25	●	180	37

Design:

Hydraulic clamping bracket for set-up-time-optimised clamping on KH10.2 clamping stations. Pull-studs installed underneath.

The quick-coupling plug is pre-mounted, and the integrated blow-out function can be individually connected.

Note:

* Please observe the installation instructions.

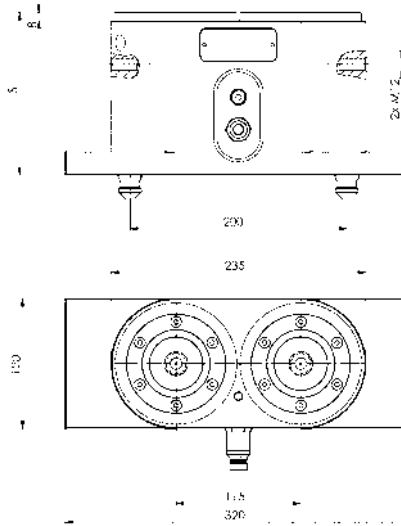

No. 6204K2HA-013

2-point clamping bracket

Hydraulic unlocking.
 Pneumatic blow-out.
 Opening operating pressure: min. 50 bar - max. 60 bar.
 Clamping modules' contact surface: Steel, stainless and hardened.
 Base plate: Steel, unhardened.
 Repetition accuracy < 0.005 mm.



Order no.	Size	Pull-in/locking force up to [kN]	Holding force* [kN]	Blow out	S [mm]	Weight [Kg]
427906	KH10.2	2 x 10	2 x 25	●	190	57
427575	KH10.2	2 x 10	2 x 25	●	220	63

Design:

Hydraulic clamping bracket for set-up-time-optimised clamping on KH10.2 clamping stations. Pull-studs installed underneath.

The quick-coupling plug is pre-mounted, and the integrated blow-out function can be individually connected.

Note:

* Please observe the installation instructions.

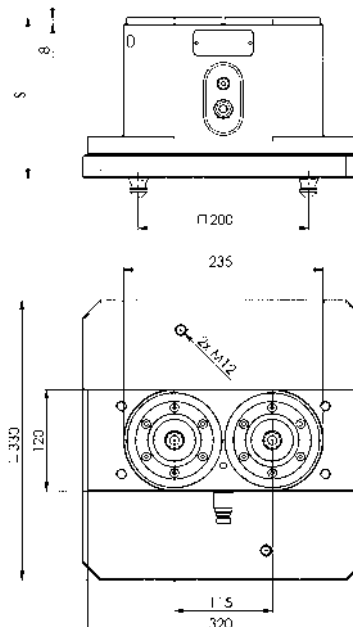

Subject to technical alterations.

No. 6204K2HA-001

2-point clamping bracket

Hydraulic unlocking.
 Pneumatic blow-out.
 Opening operating pressure: min. 50 bar - max. 60 bar.
 Clamping modules' contact surface: Steel, stainless and hardened.
 Base plate: Steel, unhardened.
 Repetition accuracy < 0.005 mm.



Order no.	Size	Pull-in/locking force up to [kN]	Holding force* [kN]	Blow out	S [mm]	Weight [Kg]
427666	KH10.2	2 x 10	2 x 25	●	70	18
427682	KH10.2	2 x 10	2 x 25	●	100	26
427708	KH10.2	2 x 10	2 x 25	●	120	31
427724	KH10.2	2 x 10	2 x 25	●	160	42
427740	KH10.2	2 x 10	2 x 25	●	200	54

Design:

Hydraulic clamping bracket for set-up-time-optimised clamping on KH10.2 clamping stations. Pull-studs installed underneath.
 The quick-coupling plug is pre-mounted, and the integrated blow-out function can be individually connected.

Note:

* Please observe the installation instructions.

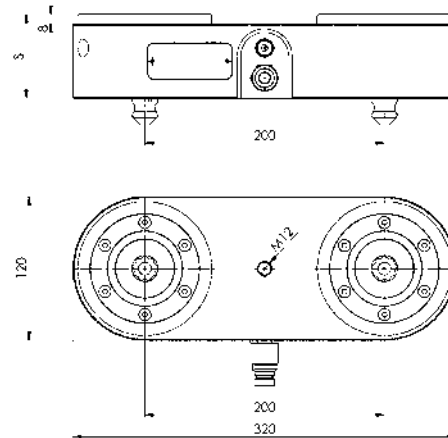

No. 6204K2HA-006

2-point clamping bracket

Hydraulic unlocking.
 Pneumatic blow-out.
 Clamping modules' contact surface: Steel, stainless and hardened.
 Base plate: Steel, unhardened.
 Repetition accuracy < 0.005 mm.



Order no.	Size	Pull-in/locking force up to [kN]	Holding force* [kN]	Blow out	S [mm]	Weight [Kg]
427765	KH10.2	2 x 10	2 x 25	●	110	45
427781	KH10.2	2 x 10	2 x 25	●	140	53
427807	KH10.2	2 x 10	2 x 25	●	160	58
427823	KH10.2	2 x 10	2 x 25	●	200	69
427849	KH10.2	2 x 10	2 x 25	●	240	81

Design:

Hydraulic clamping bracket for set-up-time-optimised clamping on KH10.2 clamping stations. Pull-studs installed underneath.
 The quick-coupling plug is pre-mounted, and the integrated blow-out function can be individually connected.

Note:

* Please observe the installation instructions.

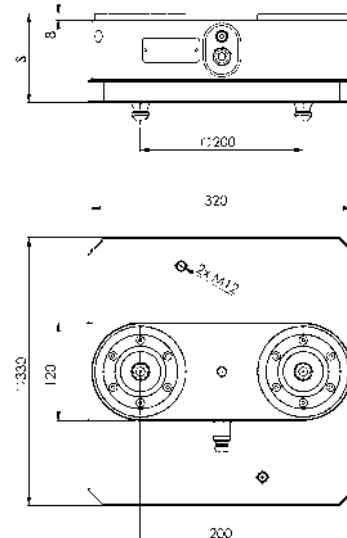

Subject to technical alterations.

No. 6204S6HA-008

6-point clamping station

Hydraulic unlocking.

Pneumatic blow-out.

Clamping modules' contact surface: Steel, stainless and hardened.

Base plate: Steel, unhardened.

Repetition accuracy < 0.005 mm.

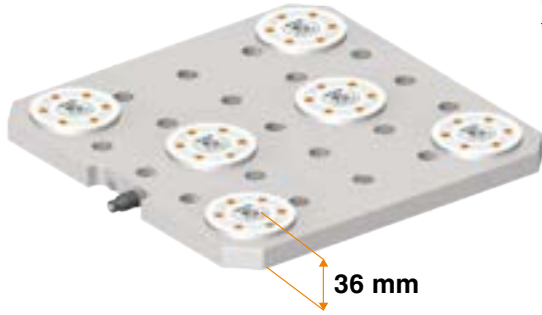

Order no.	Size	Pull-in/locking force up to [kN]	Holding force* [kN]	Blow out	Weight [Kg]
427625	KH10.2	6x10	6x25	●	55

Design:

Hydraulic clamping station for optimised clamping times on machine tables with distance between slots of 100 mm. Clamping is with M16 socket head screws. At least two fitting holes are attached for alignment.

The quick coupling plug is pre-mounted, and the integrated blow-out function can be individually connected.

Advantage:

Low overall height of only 36 mm.

Note:

* Please observe the installation instructions.

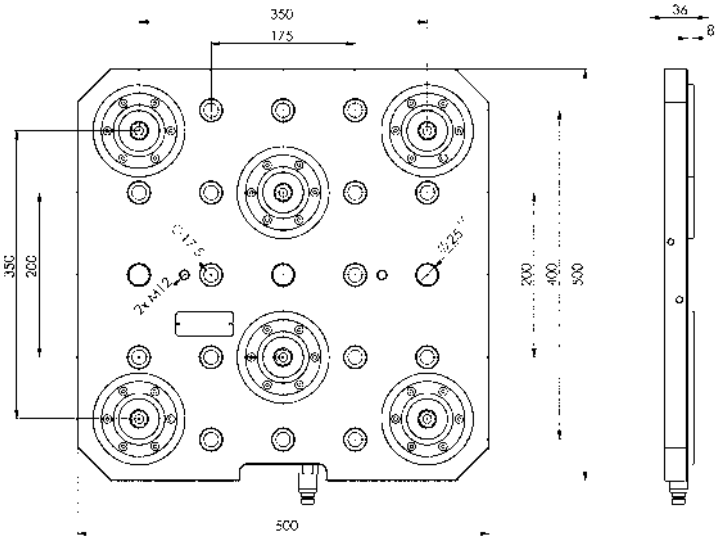

CAD



No. 6204WU12HA-001

12-point clamping cube

Hydraulic unlocking.

Pneumatic blow-out.

Clamping modules' contact surface: Steel, stainless and hardened.

Base plate: Steel, unhardened.

Repetition accuracy < 0.005 mm.



Order no.	Size	Pull-in/locking force up to [kN]	Holding force* [kN]	Blow out	Weight [Kg]
427641	KH10.2	12x10	12x25	●	210

Design:

Hydraulic clamping cube for set-up-time-optimised clamping on clamping station 6204S6HA-008. Fastening is with pull-studs installed underneath.

The pitch spacing of the clamping modules is 200 mm. The quick-coupling plug is pre-mounted, and the integrated blow-out function can be individually connected.

Note:

* Please observe the installation instructions.

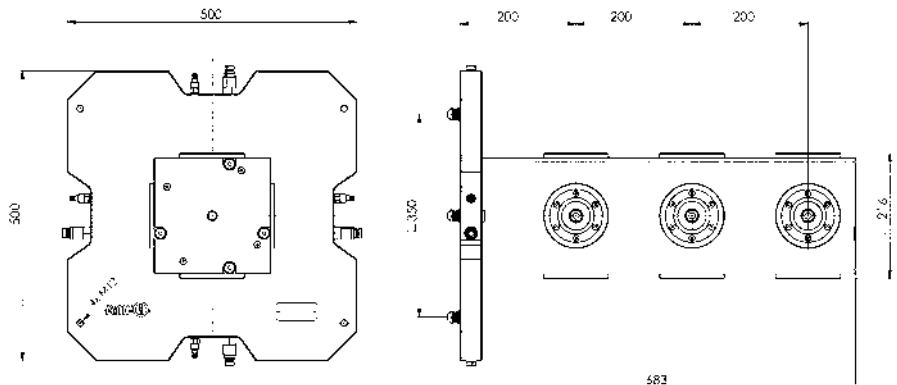

Subject to technical alterations.



No. 6206S2L

2-point clamping station

Pneumatic unlocking.
 Opening operating pressure:
 KP10.3 min. 5 bar.
 KP20.3 min. 4.5 bar.
 Steel, unhardened.
 Repeat accuracy < 0.005 mm.

Order no.	Size	Pull-in/locking force up to	Holding force*	Weight
		[kN]	[kN]	[Kg]
550249	KP10.3	2 x 10	2 x 25	13
550254	KP20.3	2 x 17	2 x 55	24

Design:

Pneumatic clamping station for setting time-optimised clamping on machine tables with groove spacing of 63, 100 and 125 mm. Fastening is via M12 socket head screws. At least two fitting bores are attached for alignment.
 The insertion dimension of the clamping modules is 200 mm.
 The pneumatic quick-coupler is premounted.

Advantage:

- Low overall height

Note:

* Please observe the installation instructions.

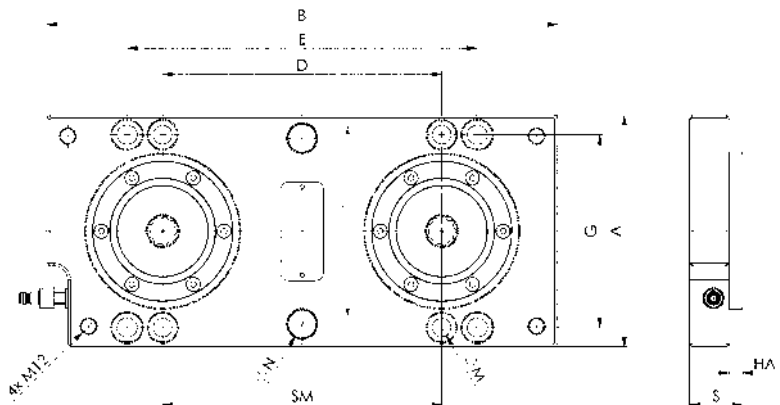

Dimensions:

Order no.	Size	A	B	C	D	E	G	HA	dia. N	dia. M	S	SM
550249	KP10.3	166	366	133	200	250 - 252	138	10	20	13,5	38	200
550254	KP20.3	196	366	160	200	250 - 252	165	15	20	13,5	53	200

CAD



Subject to technical alterations.

No. 6206S4L

4-point clamping station

Pneumatic unlocking.
 Opening operating pressure:
 KP10.3 min. 5 bar.
 KP20.3 min. 4.5 bar.
 Steel, unhardened.
 Repeat accuracy < 0.005 mm.

Order no.	Size	Pull-in/locking force up to	Holding force*	Weight [Kg]
		[kN]	[kN]	
550251	KP10.3	4 x 10	4 x 25	30
550255	KP20.3	4 x 17	4 x 55	51

Design:

Pneumatic clamping station for setting time-optimised clamping on machine tables with groove spacing of 63, 100 and 125 mm. Fastening is via M12 socket head screws. At least two fitting bores are attached for alignment.
 The insertion dimension of the clamping modules is 200 mm.
 The pneumatic quick-coupler is premounted.

Advantage:

- Low overall height

Note:

* Please observe the installation instructions.

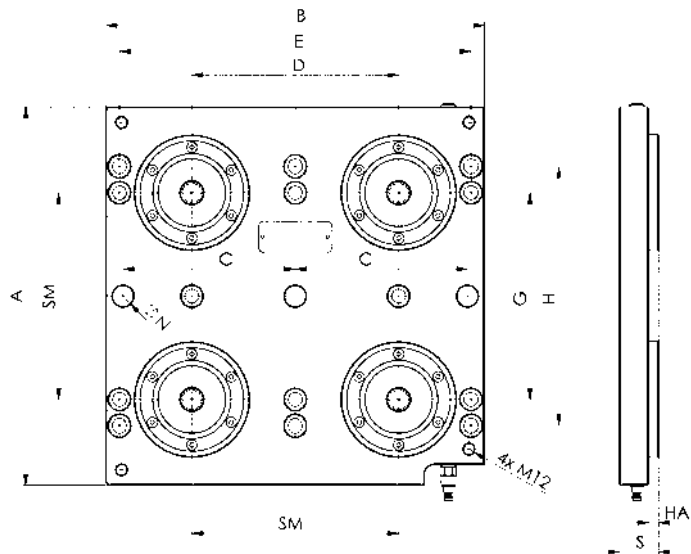
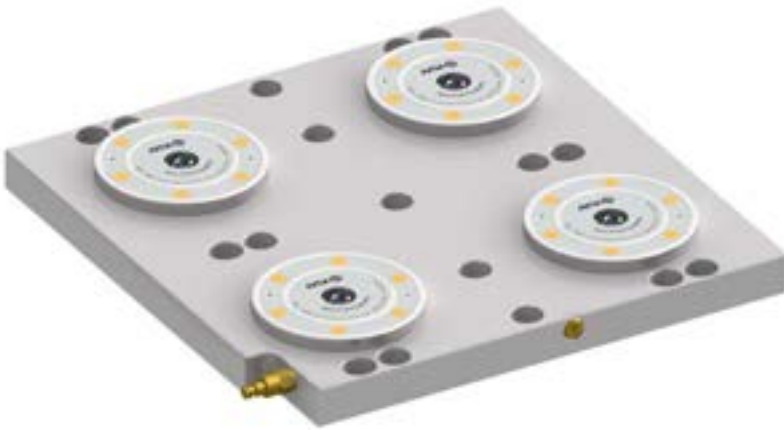

Dimensions:

Order no.	Size	A	B	C	D	E	G	H	HA	dia. N	dia. M	S	SM
550251	KP10.3	366	366	166,5	200	340	200	250 - 252	10	20	13,5	38	200
550255	KP20.3	399	399	183,5	200	370	200	250 - 252	15	20	13,5	53	200



No. 6206S6L

6-point clamping station

Pneumatic unlocking.
 Opening operating pressure:
 KP10.3 min. 5 bar.
 KP20.3 min. 4.5 bar.
 Steel, unhardened.
 Repeat accuracy < 0.005 mm.

Order no.	Size	Pull-in/locking force up to	Holding force*	Weight
		[kN]	[kN]	[Kg]
550252	KP10.3	6 x 10	6 x 25	46
550256	KP20.3	6 x 17	6 x 55	76

Design:

Pneumatic clamping station for setting time-optimised clamping on machine tables with groove spacing of 63, 100 and 125 mm. Fastening is via M12 socket head screws. At least two fitting bores are attached for alignment.
 The insertion dimension of the clamping modules is 200 mm.
 The pneumatic quick-coupler is premounted.

Advantage:

- Low overall height

Note:

* Please observe the installation instructions.

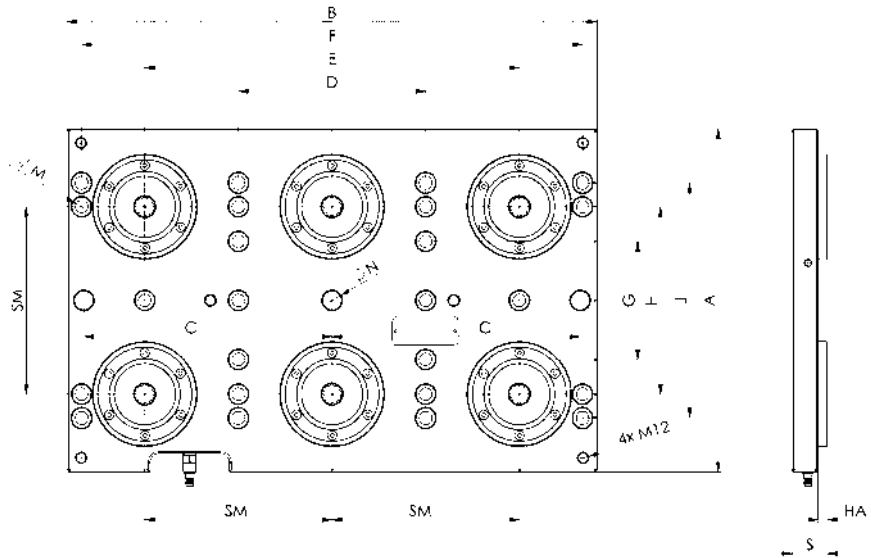

Dimensions:

Order no.	Size	A	B	C	D	E	F	G	H	HA	J	dia. N	dia. M	S	SM
550252	KP10.3	366	566	265	200	400	535	126	200	10	250 - 252	20	13,5	38	200
550256	KP20.3	396	596	265	200	400	565	126	200	15	250 - 252	20	13,5	53	200



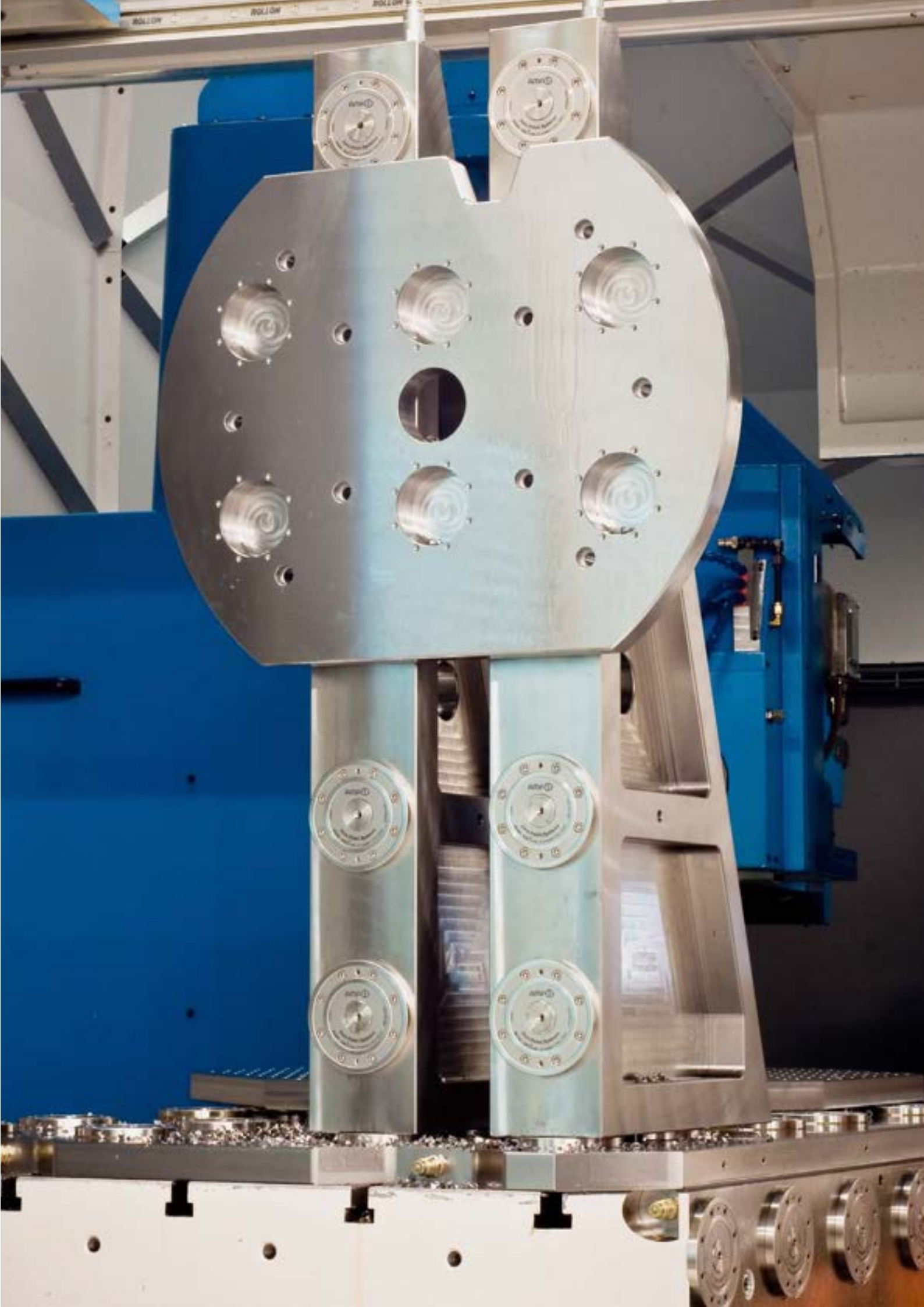

No. 6211S

4-point clamping station

K20: hydraulic unlocking.
 K20.3: pneumatic unlocking.
 Pneumatic blow-out.
 repetition accuracy < 0.005 mm.

Size	pneumatic	hydraulic	speed max. [1/min]
KH20	-	●	2200
KP20.3	●	-	2200

Application:

Pneumatic or hydraulic clamping station for setting time-optimised clamping for milling-turning machining.

Note:

Fastening to the machine table is via socket head screws.

On request:

Further dimensions, different pitch circles and number of modules.

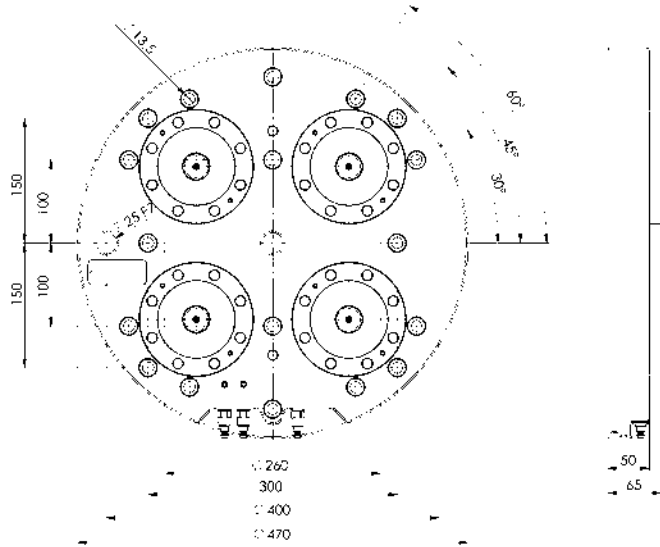

CAD



No. 6211P

Fixture plate

Steel, unhardened, suitable for 4-point clamping station

Size	pneumatic	hydraulic
20	-	●
20.3	●	-

Note:

The interchangeable pallet is designed for milling-turning machining and is suitable for clamping stations with 4 clamping modules K20 and K20.3, which are arranged on the 260 mm pitch circle.

On request:

Additional dimensions, different pitch circles and number of pull-studs.

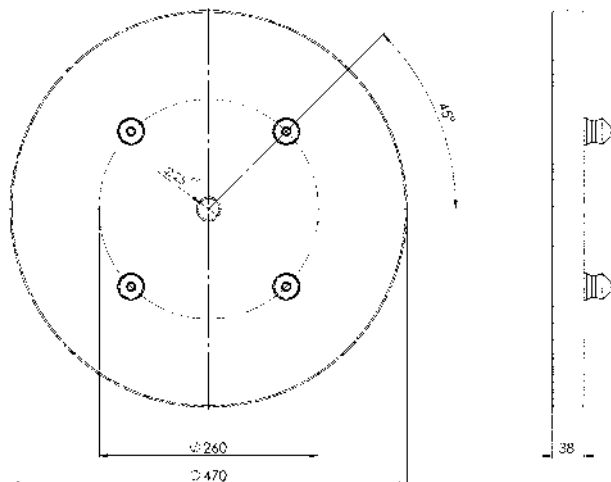

CAD



Subject to technical alterations.

OUR ZERO-POINT SYSTEM FOR YOUR MILLING-TURNING MACHINING - QUICK, PRECISE, DURABLE, SIMPLY CONVINCING!

The benefits to you at a glance:

- > Connection for opening the clamping station via the media duct in the machine table or a side connection for manual actuation.
- > Opening pressure for unlocking the clamping modules just 4.5 bar.
- > Only one pneumatic connection required to open the clamping modules.
- > Locking via the self-locking and positive fit mechanism of the clamping modules.
- > Cylindrical clamping nipple mount - hence high precision and durability.
- > Great process reliability through integrated support control and direct clamping control.
- > With integrated queries also suitable for automated loading.



No. 6370S2-001

2-point clamping station

Hydraulic unlocking.
 Opening operating pressure: min. 50 bar - max. 60 bar.
 Clamping modules' contact surface: Steel, stainless and hardened.
 Base plate: Steel, unhardened.
 Repetition accuracy < 0.005 mm.



Order no.	Size	Pull-in/locking force up to	Holding force*	Weight
		[kN]	[kN]	[Kg]
303263	KH20	2 x 20	2 x 55	18
303271	KH40	2 x 40	2 x 105	33

Note:

On request, we can incorporate fastening bores in the base plate according to your requirements. The correct quick-release coupling is available under the order no.:

- 427872 for sleeve
- 427856 for plug

* Please observe the installation instructions.

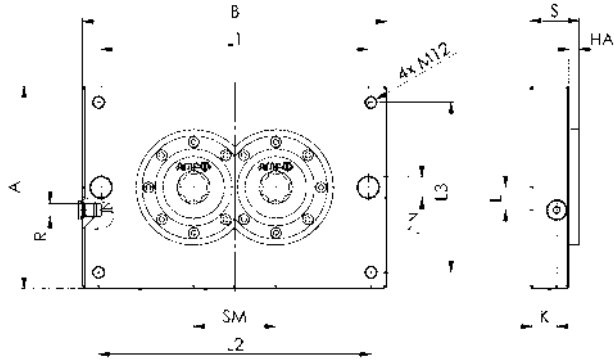

Dimensions:

Order no.	Size	A	B	HA	K	L	L1	L2	L3	dia. N	R	S	SM
303263	KH20	196	296	10	26	22	260	265	165	20	G1/4	48	80
303271	KH40	246	346	15	33	22	300	315	215	25	G1/4	62	110



No. 6370S2-002

2-point clamping station

Hydraulic unlocking.
 Opening operating pressure: min. 50 bar - max. 60 bar.
 Clamping modules' contact surface: Steel, stainless and hardened.
 Base plate: Steel, unhardened.
 Repetition accuracy < 0.005 mm.



Order no.	Size	Pull-in/locking force up to		Holding force*		Weight
		[kN]	[kN]	[kN]	[Kg]	
426726	KH10	2 x 10	2 x 25	7,5		
303289	KH20	2 x 20	2 x 55	22,9		
303297	KH40	2 x 40	2 x 105	59,8		

Note:

On request, we can incorporate fastening bores in the base plate according to your requirements. The correct quick-release coupling is available under the order no.:

- 427872 for sleeve
- 427856 for plug

* Please observe the installation instructions.

On request:

Other dimensions, insertion dimensions and number of clamping nipples equipped.

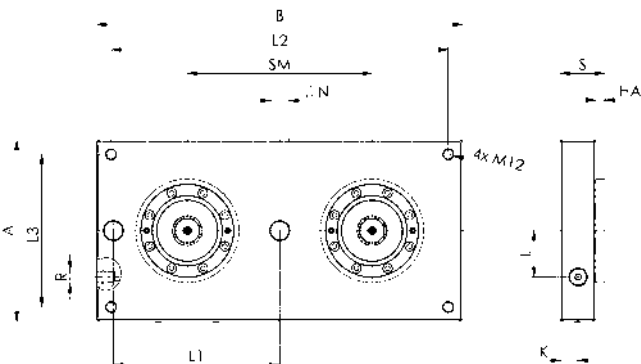

Dimensions:

Order no.	Size	A	B	HA	K	L	L1	L2	L3	dia. N	R	S	SM
426726	KH10	146	240	7	15	35	100	210	116	20	G1/4	33	100
303289	KH20	196	396	10	19	50	180	365	165	20	G1/4	48	200
303297	KH40	296	546	15	24	65	250	515	266	25	G1/4	62	320



No. 6370S4-001

4-point clamping station

Hydraulic unlocking.

Opening operating pressure: min. 50 bar - max. 60 bar.

Clamping modules' contact surface: Steel, stainless and hardened.

Base plate: Steel, unhardened.

Repetition accuracy < 0.005 mm.

Order no.	Size	Pull-in/locking force up to	Holding force*	Weight [Kg]
		[kN]	[kN]	
426742	KH10	4 x 10	4 x 25	12,5
303321	KH20	4 x 20	4 x 55	46,5
303339	KH40	4 x 40	4 x 105	113,5

Note:

On request, we can incorporate fastening bores in the base plate according to your requirements.

The correct quick-release coupling is available under the order no.:

- 427872 for sleeve

- 427856 for plug

* Please observe the installation instructions.

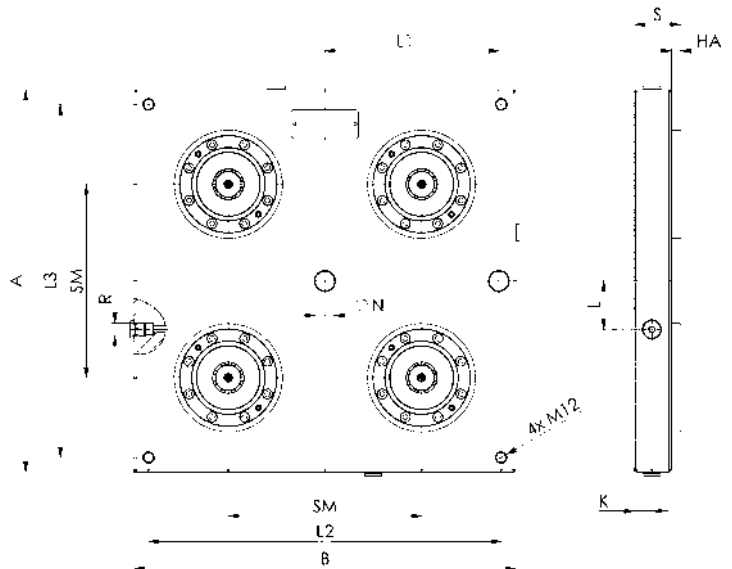

Dimensions:

Order no.	Size	A	B	HA	K	L	L1	L2	L3	dia. N	R	S	SM
426742	KH10	240	240	7	12	85	100	220	202	20	G1/4	33	100
303321	KH20	395	395	10	18	50	180	365	365	20	G1/4	48	200
303339	KH40	546	546	15	24	95	250	516	516	25	G1/4	62	320



No. 6370S6-001

6-point clamping station

Hydraulic unlocking.

Opening operating pressure: min. 50 bar - max. 60 bar.

Clamping modules' contact surface: Steel, stainless and hardened.

Base plate: Steel, unhardened.

Repetition accuracy < 0.005 mm.

Order no.	Size	Pull-in/locking force up to	Holding force*	Weight
		[kN]	[kN]	[Kg]
426734	KH10	6 x 10	6 x 25	17,5
424119	KH20	6 x 20	6 x 55	72,4
426759	KH40	6 x 40	6 x 105	178,5

Note:

On request, we can incorporate fastening bores in the base plate according to your requirements.

The correct quick-release coupling is available under the order no.:

- 427872 for sleeve

- 427856 for plug

* Please observe the installation instructions.

On request:

Other dimensions, insertion dimensions and number of clamping nipples equipped.

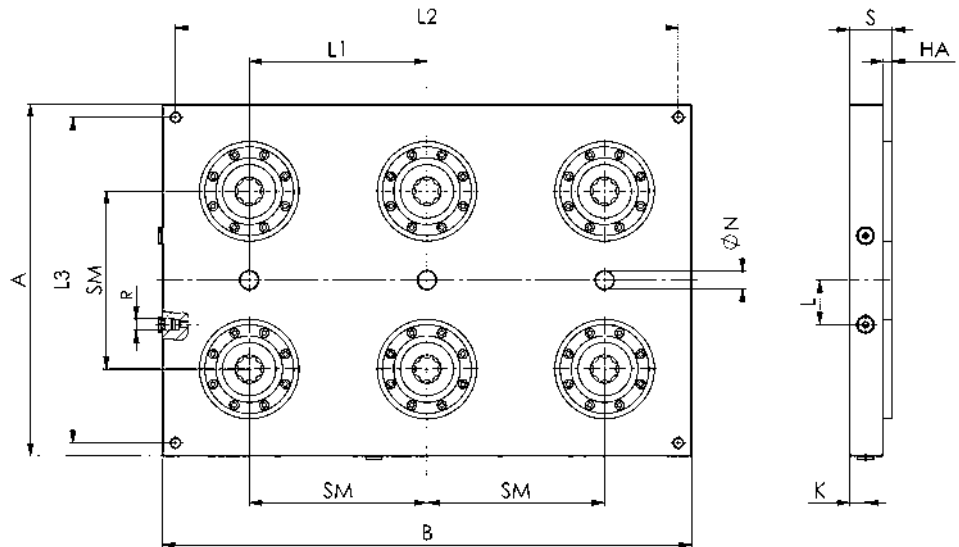

Dimensions:

Order no.	Size	A	B	HA	K	L	L1	L2	L3	dia. N	R	S	SM
426734	KH10	240	340	7	15	84	100	310	210	20	G1/4	33	100
424119	KH20	396	596	10	18	50	200	566	366	20	G1/4	48	200
426759	KH40	546	846	15	24	95	320	815	515	20	G1/4	62	320



CAD

Subject to technical alterations.



No. 6204P-S2

Fixture plate

Aluminium, suitable for 2-point clamping station KH10.2.

Order no.	Size	A	B	G	G1	G2	L	L1	S	SM	Weight [Kg]
429266	10.2	166	396	M12	M5	M8	90	120	30	200	6

Note:

On request, we can incorporate mounting holes according to your specifications in the fixture plate.

On request:

Other dimensions, pitch spacings and number of equipped pull-studs.

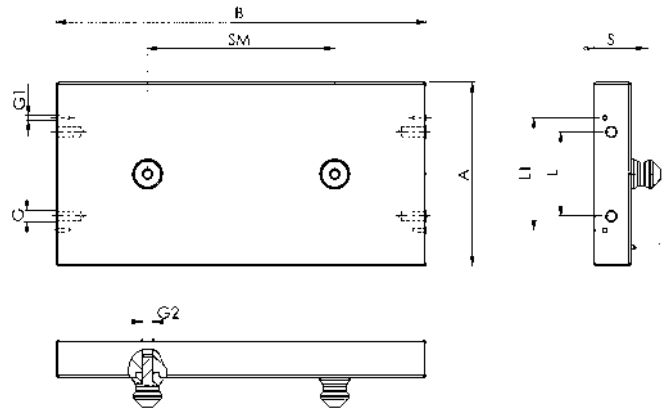
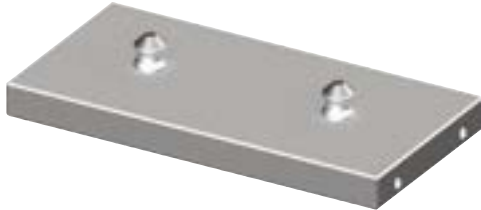

CAD



No. 6204P-S4

Fixture plate

Aluminium, suitable for 4-point clamping station KH10.2.

Order no.	Size	A	B	G	G1	G2	L	L1	S	SM	Weight [Kg]
429282	10.2	366	366	M12	M5	M8	200	120	30	200	10

Note:

On request, we can incorporate mounting holes according to your specifications in the fixture plate.

On request:

Other dimensions, pitch spacings and number of equipped pull-studs.

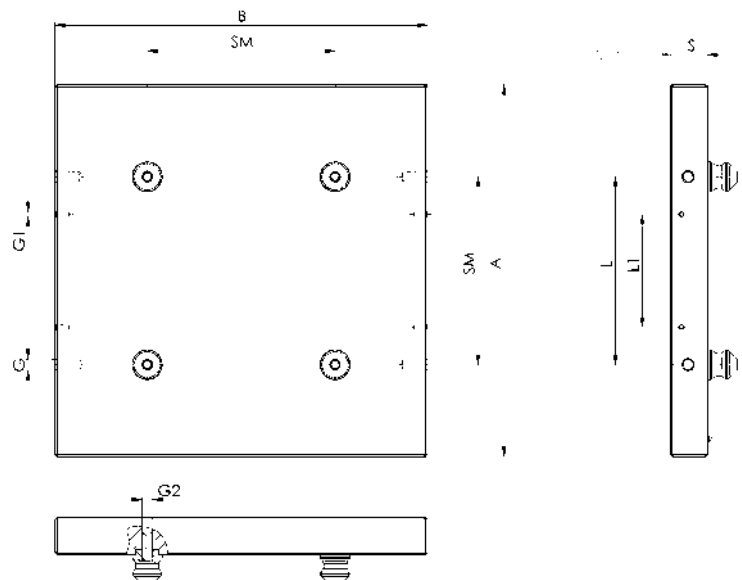

CAD



Subject to technical alterations.

No. 6204P-S6

Fixture plate

Aluminium, suitable for 6-point clamping station KH10.2.

Order no.	Size	A	B	G	G2	L	S	SM	Weight [Kg]
429308	10.2	366	566	M12	M8	200	30	200	16

Note:

On request, we can incorporate mounting holes according to your specifications in the fixture plate.

On request:

Other dimensions, pitch spacings and number of equipped pull-studs.

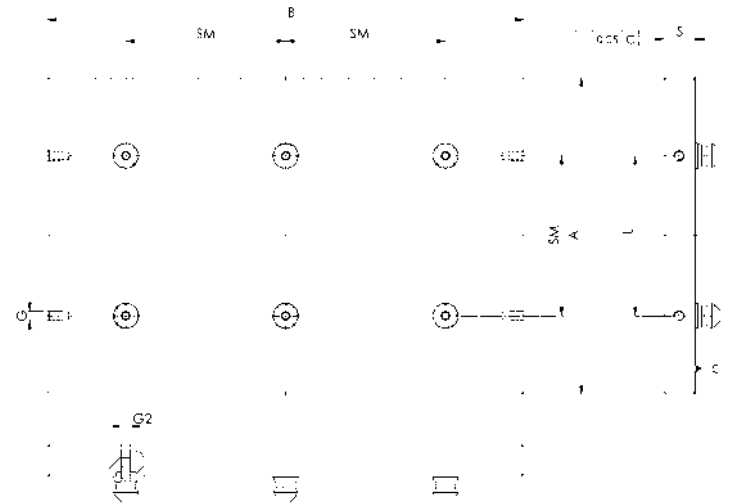
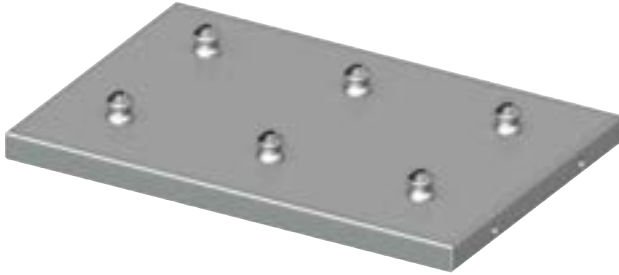

No. 6204P-S8

Fixture plate

Aluminium, suitable for 8-point clamping station KH10.2.

Order no.	Size	A	B	G	G2	L	S	SM	Weight [Kg]
429324	10.2	366	770	M12	M8	200	30	200	22

Note:

On request, we can incorporate mounting holes according to your specifications in the fixture plate.

On request:

Other dimensions, pitch spacings and number of equipped pull-studs.

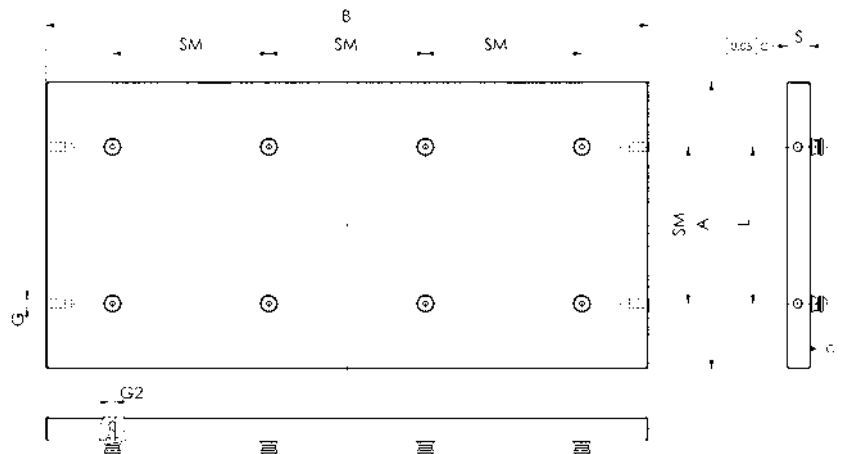

Subject to technical alterations.

No. 6370P2

Fixture plate

Aluminium, suitable for double clamping station.

Order no.	Size	A	B	G	G1	G2	L	L1	S	SM	Weight [Kg]
426700	10	146	240	M12	M5	M8	90	120	30	100	2,5
425041	20	196	396	M12	M5	M12	90	120	40	200	6,0
426783	40	296	546	M12	-	M16	120	-	45	320	19,0

Note:

Fastening bores for handles are attached to the end faces of the interchangeable pallets. See dimensions table L1 and G1. We can incorporate additional fastening bores according to your specifications in the change pallet on request.

On request:

Other dimensions, pitch spacings and number of equipped pull-studs.

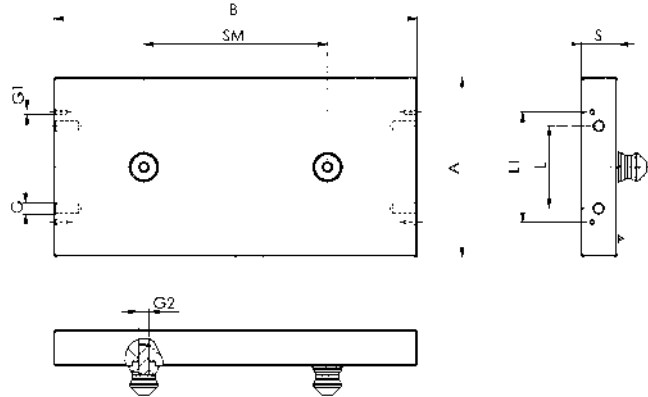

CAD



No. 6370P4

Fixture plate

Aluminium, suitable for quadruple clamping station.

Order no.	Size	A	B	G	G1	G2	L	L1	S	SM	Weight [Kg]
426767	10	240	240	M12	M5	M8	120	90	30	100	4,5
425033	20	396	396	M12	M5	M12	200	120	40	200	16,0
426809	40	546	546	M12	-	M16	320	-	45	320	35,0

Note:

Fastening bores for handles are attached to the end faces of the interchangeable pallets. See dimensions table L1 and G1. We can incorporate additional fastening bores according to your specifications in the change pallet on request.

On request:

Other dimensions, pitch spacings and number of equipped pull-studs.

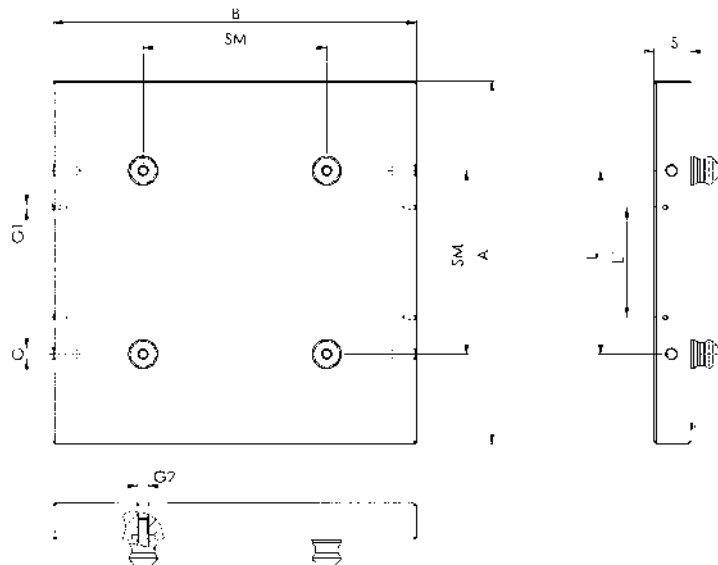

CAD



Subject to technical alterations.

No. 6370P6

Fixture plate

Aluminium, suitable for sextuple clamping station.

Order no.	Size	A	B	G	G2	L	S	SM	Weight [Kg]
426775	10	240	386	M10	M8	120	30	100	7,5
426791	20	396	596	M12	M12	200	40	200	25,0
426817	40	546	866	M12	M16	320	45	320	56,0

Note:

On request, we can incorporate mounting holes according to your specifications in the change pallet.

On request:

Other dimensions, pitch spacings and number of equipped pull-studs.

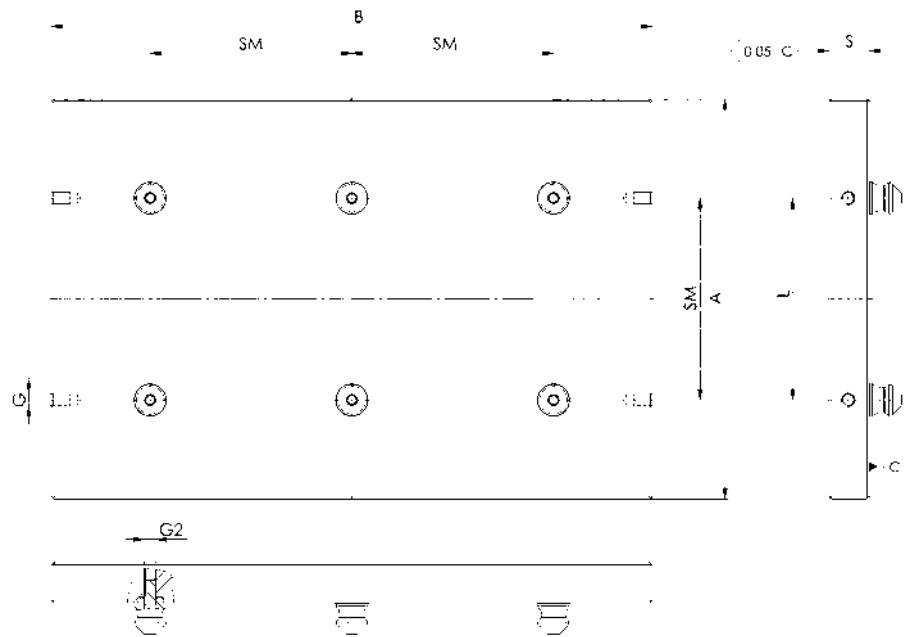
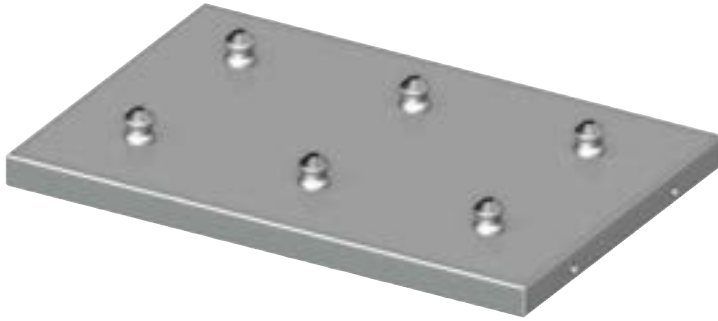

CLASSIC CLAMPING SLEEVE ARRANGEMENT

This arrangement with two zero-point clamping sleeves always optimally positions the interchangeable pallet. The compensation pull-studs can be moved radially and can compensate for larger distance tolerances in all directions. An arrangement solely with zero-point adapter sleeves is also possible.

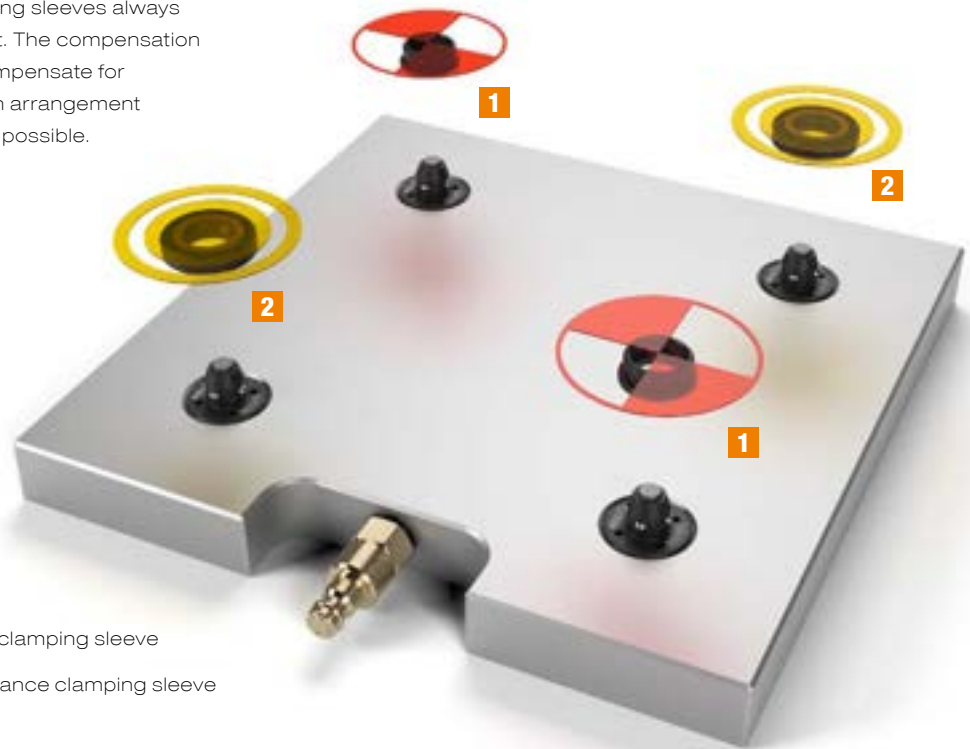

- 1** Zero-point clamping sleeve
- 2** Counterbalance clamping sleeve

OPTIONAL CLAMPING SLEEVE ARRANGEMENT

The greatest possible compensation can be achieved by solely arranging compensation pull-studs. This is employed when the repetition accuracy only plays a minor role or the positioning is carried out by additional alignment elements.

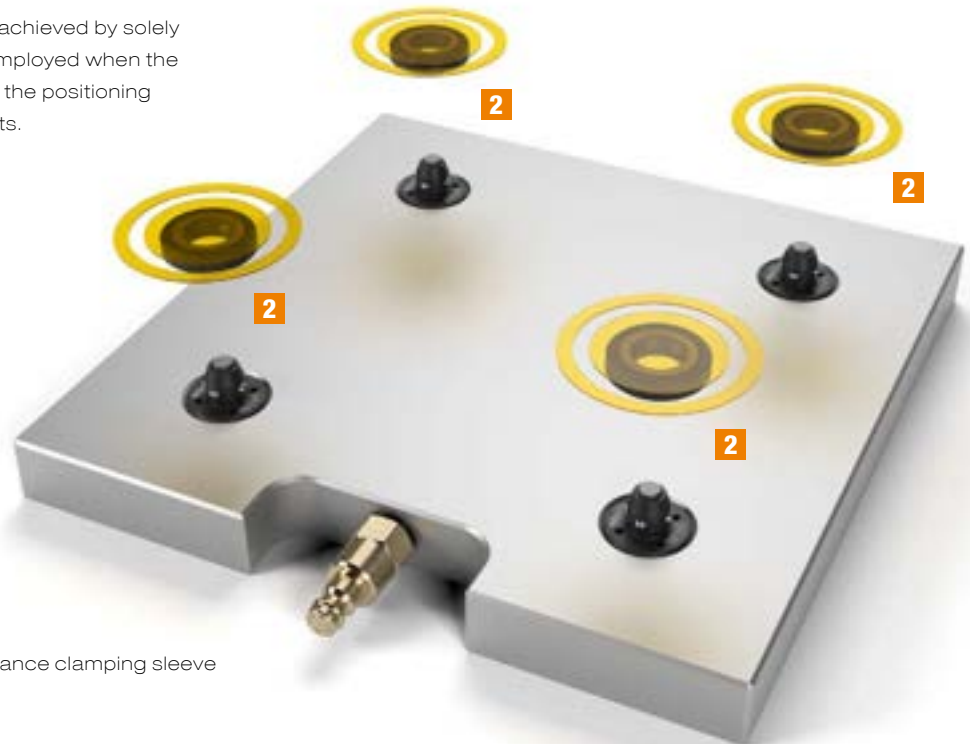

- 2** Counterbalance clamping sleeve

No. 6214ZN-250-01

Zero-point clamping sleeve

For screwing on.
Hardened.

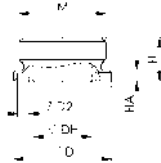

Order no.	Size	dia. D	dia. D2	ØDH	H	HA	M	R	Weight [g]
559092	250	18	2,1	10,7	7	1,95	M16 x 1	14,75	6

Application:

Zero point clamping sleeve suitable for pneumatic clamping module 6215RP-250 and 251 and mechanical clamping modules 6214RM-250 and 251. The clamping sleeve has an external thread and can, for example, be screwed directly into fixtures or workpieces.

Note:

The suitable installation tool is available under the order no. 559439.

On request:

- Installation diagrams

No. 6214ZN-250-02

Counterbalance clamping sleeve

For screwing on.
Hardened.

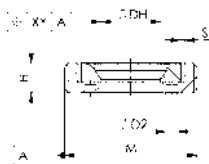
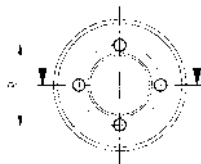

Order no.	Size	XY counterbalance [mm]	dia. D2	ØDH	H	M	R	S	Weight [g]
559093	250	1,0	2,1	10,8	5,45	M24 x 1	14,75	0,75	13

Application:

The compensation pull-stud is supported by bearings so that it is radially mobile and is used when large distance tolerances between the clamping sleeves have to be compensated. The compensating clamp is suitable for pneumatic clamping modules 6215RP-250 and 251 and mechanical clamping modules 6214RM-250 and 251.

The compensating clamp sleeve has an external thread and can, for example, be screwed directly into fixtures or workpieces.

Note:

The clamping sleeve has only a holding function and does not absorb any lateral load. The suitable installation tool is available under the order no. 559439.

On request:

- Installation diagrams

No. 6214ZN-250-03

Zero-point clamping sleeve

For pressing in.
Hardened.

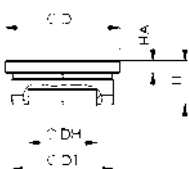

NEW!

Order no.	Size	dia. D	dia. D1	ØDH	H	HA	Weight [g]
567135	250	18	16	10,7	6,9	1,95	6

Application:

Zero point clamping sleeve suitable for pneumatic clamping module 6215RP-250 and 251 and mechanical clamping modules 6214RM-250 and 251. The clamping sleeve has an external thread and can, for example, be screwed directly into fixtures or workpieces.

On request:

- Installation diagrams

CLASSIC PULL-STUD ARRANGEMENT

This arrangement of the clamping modules always optimally positions the pallet to be changed. At the same time, the zero-point pull-stud always represents the reference point. The timing pull-stud serves to compensate for the free axis. The undersize pull-stud has only a clamping and holding function.



- 1** Zero-point pull-stud
- 2** Timing pull-stud
- 3** Undersize pull-stud

OPTIONAL PULL-STUD ARRANGEMENT

The exclusive use of timing pull-studs compensates for stronger temperature influences. The reference point always remains in the centre of the pallet. Of course, temperature influences from machine processing can generally be ignored since the heat generated is conducted away by the chips and coolant.



- 2** Timing pull-stud

No. 6203ZN-140

Pull-stud size 140

Hardened, for pneumatic clamping module no. 6203SP-140.



NEW!



Order no.	Size	dia. DN	dia. D1	H	H1	M	T	T1	TORX	Weight [g]
564840	140	7,00	5	11,2	8,7	M3	2,5	4,5	T8	2
564841	140	7,00	5	11,2	8,7	M3	2,5	4,5	T8	2
564842	140	6,96	5	11,2	8,7	M3	2,5	4,5	T8	2

Design:

Order no. 564840: zero-point pull-stud, Order no. 564841: timing pull-stud, Order no. 564842: undersize pull-stud.

Zero point and undersize pull-stud incl. threaded stud ISO 4026 M3x12-10.9 (galvanised).

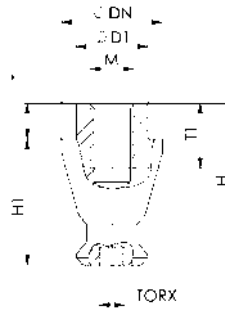

No. 6203ZN-150

Pull-stud size 150

Hardened, for pneumatic clamping module no. 6203SP-150 and 6109SP-150.



Order no.	Size	dia. DN	dia. D1	H	H1	M	T	T1	SW	Weight [g]
427302	150	10,0	7,14	17,5	15	M5	2,5	8,5	6	4
427328	150	10,0	7,14	17,5	15	M5	2,5	8,5	6	4
427344	150	9,95	7,14	17,5	15	M5	2,5	8,5	6	4

Design:

Order no. 427302: zero-point pull-stud, Order no. 427328: timing pull-stud, Order no. 427344: undersize pull-stud.

Zero point, timing and undersize pull-stud incl. threaded stud ISO 4026 M5x20-10.9 (galvanised).

Note:

A suitable tool for aligning the slit pull-stud is available under the order no. 562804.

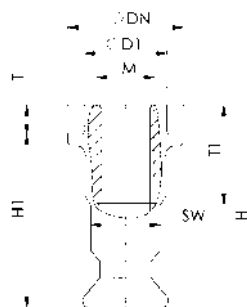

No. 6370ZN-5

Pull-stud size 5 for M6 engagement screw

Hardened, for clamping modules size 5.



Order no.	Size	dia. DN	dia. D1	dia. D2	H	H1	M	T	Weight [g]
306019	5	15,0	10	6	12,7	10,2	-	2,5	15
306035	5	15,0	10	6	12,7	10,2	-	2,5	15
306050	5	14,8	10	6	12,7	10,2	-	2,5	15
306076	5	14,8	-	-	-	-	M 6	-	12

Design:

order no. 306019: zero point pull-stud, order no. 306035: timing pull-stud, order no. 306050: undersize pull-stud, order no. 306076: protection pull-stud

On request:

Protection pull-stud made of plastic.



No. 6370ZN-5

Pull-stud size 5 for M8 engagement screw

Hardened, for clamping modules size 5.



Order no.	Size	dia. DN	dia. D1	dia. D2	H	H1	M	T	Weight [g]
562192	5	15,0	11	8	11,9	9,4	-	2,5	8
562193	5	15,0	11	8	11,9	9,4	-	2,5	8
562194	5	14,8	11	8	11,9	9,4	-	2,5	8
306076	5	14,8	-	-	-	-	M 6	-	12

Design:

order no. 562192: zero point pull-stud, order no. 562193: timing pull-stud, order no. 562194: undersize pull-stud, order no. 306076: protection pull-stud

On request:

Protection pull-stud made of plastic.

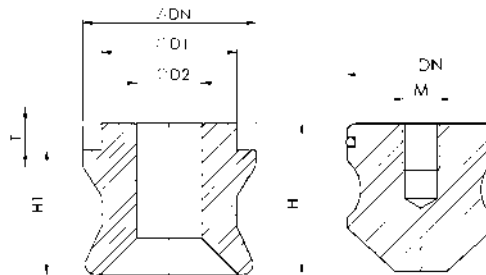

No. 6370ZN-10

Pull-stud size 10 for M8 engagement screw

Hardened, for clamping modules size 10.



Order no.	Size	dia. DN	dia. D1	dia. D2	H	H1	M	T	Weight [g]
303610	10	22,0	15	8	19	16	-	3	30
303636	10	22,0	15	8	19	16	-	3	30
304519	10	21,8	15	8	19	16	-	3	30
304535	10	21,8	-	-	-	-	M 8	-	30

Design:

Order no. 303610: zero point pull-stud, order no. 303636: timing pull-stud, order no. 304519: undersize pull-stud, order no. 304535: protection pull-stud

Note:

The timing pull-stud has an additional alignment bore, which can optionally be used for simple installation.

On request:

Protection pull-stud made of plastic.

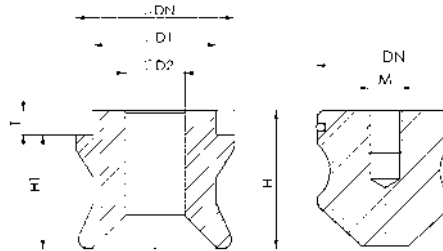

No. 6370ZNR-10

Pull-stud size 10 for M8 engagement screw with reduced fitting collar

Hardened, for clamping modules size 10.



Order no.	Size	dia. DN	dia. D1	dia. D2	H	H1	M	T	Weight [g]
562748	10	22,0	14,5	8	19	16	-	3	27
562750	10	22,0	14,5	8	19	16	-	3	27
562751	10	21,8	14,5	8	19	16	-	3	27
304535	10	21,8	-	-	-	-	M 8	-	30

Design:

Order no. 562748: zero point pull-stud, order no. 562750: timing pull-stud, order no. 562751: undersize pull-stud, order no. 304535: protection pull-stud

Application:

For clamping in a fitting hole with a reduced diameter e.g. before heat treatment of a workpiece. After the boring out the hole, the respective standard pull-stud can be used.

Note:

The timing pull-stud has an additional alignment bore, which can optionally be used for simple installation.

On request:

Protection pull-stud made of plastic.

No. 6370ZN-10

Pull-stud size 10 with colour coding for M8 engagement screw

Hardened, for clamping modules size 10.



Order no.	Size	dia. DN	dia. D1	dia. D2	H	H1	T	Weight [g]
430280	10	22,0	15	8	19	16	3	30
430306	10	22,0	15	8	19	16	3	30

Design:

Extremely wear-resistant surface coating. Order no. 430280: zero point pull-stud „Gold“, order no. 430306: timing pull-stud „Black“.

Application:

For simple, visual differentiation of the various pull-studs.

Note:

The timing pull-stud has an additional alignment bore, which can optionally be used for simple installation.

No. 6370ZN-10

Pull-stud size 10 for M10 engagement screw

Hardened, for clamping modules size 10.



Order no.	Size	dia. DN	dia. D1	dia. D2	H	H1	M	T	Weight [g]
554936	10	22,0	15	10	19	16	-	3	27
554937	10	22,0	15	10	19	16	-	3	27
554938	10	21,8	15	10	19	16	-	3	27
304535	10	21,8	-	-	-	-	M 8	-	30

Design:

order no. 554936: zero point pull-stud, order no. 554937: timing pull-stud, order no. 554938: undersize pull-stud, order no. 304535: protection pull-stud

Note:

The timing pull-stud has an additional alignment bore, which can optionally be used for simple installation.

On request:

Protection pull-stud made of plastic.

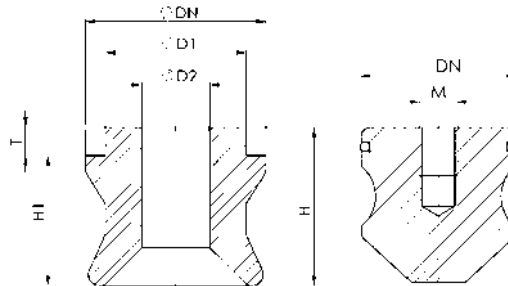

No. 6370ZNR-10

Pull-stud size 10 for M10 engagement screw with reduced fitting collar

Hardened, for clamping modules size 10.



Order no.	Size	dia. DN	dia. D1	dia. D2	H	H1	M	T	Weight [g]
562755	10	22,0	14,5	10	19	16	-	3	27
562757	10	22,0	14,5	10	19	16	-	3	27
562759	10	21,8	14,5	10	19	16	-	3	27
304535	10	21,8	-	-	-	-	M 8	-	30

Design:

Order no. 562755: zero point pull-stud, order no. 562757: timing pull-stud, order no. 562759: undersize pull-stud, order no. 304535: protection pull-stud

Application:

For clamping in a fitting hole with a reduced diameter e.g. before heat treatment of a workpiece. After the boring out the hole, the respective standard pull-stud can be used.

Note:

The timing pull-stud has an additional alignment bore, which can optionally be used for simple installation.

On request:

Protection pull-stud made of plastic.



No. 6370ZN-20

Pull-stud size 20 for M12 engagement screw

Hardened, for clamping modules size 20.



Order no.	Size	dia. DN	dia. D1	dia. D2	H	H1	M	T	Weight [g]
303149	20	32,0	25	12	28	23	-	5	110
303156	20	32,0	25	12	28	23	-	5	110
303164	20	31,7	25	12	28	23	-	5	110
303172	20	31,7	-	-	-	-	M 8	-	110

Design:

Order no. 303149: zero point pull-stud, order no. 303156: timing pull-stud, order no. 303164: undersize pull-stud, order no. 303172: protection pull-stud

Note:

The timing pull-stud has an additional alignment bore, which can optionally be used for simple installation.

On request:

Protection pull-stud made of plastic.

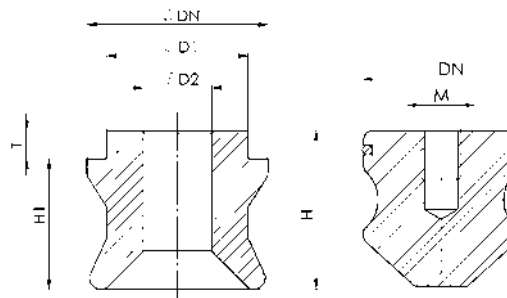

No. 6370ZNR-20

Pull-stud size 20 for M12 engagement screw with reduced fitting collar

Hardened, for clamping modules size 20.



Order no.	Size	dia. DN	dia. D1	dia. D2	H	H1	M	T	Weight [g]
562761	20	32,0	24	12	28	23	-	5	110
562764	20	32,0	24	12	28	23	-	5	110
562766	20	31,7	24	12	28	23	-	5	110
303172	20	31,7	-	-	-	-	M 8	-	110

Design:

Order no. 562761: zero point pull-stud, order no. 562764: timing pull-stud, order no. 562766: undersize pull-stud, order no. 303172: protection pull-stud

Application:

For clamping in a fitting hole with a reduced diameter e.g. before heat treatment of a workpiece. After the boring out the hole, the respective standard pull-stud can be used.

On request:

Protection pull-stud made of plastic.

No. 6370ZN-20

Pull-stud size 20 with colour coding for M12 engagement screw

Hardened, for clamping module size 20.



Order no.	Size	dia. DN	dia. D1	dia. D2	H	H1	T	Weight [g]
430322	20	32,0	25	12	28	23	5	110
430348	20	32,0	25	12	28	23	5	110

Design:

Extremely wear-resistant surface coating.

Order no. 430322: zero point pull-stud „Gold“, order no. 430348: timing pull-stud „Black“.

Application:

For simple, visual differentiation of the various pull-studs.

Note:

The timing pull-stud has an additional alignment bore, which can optionally be used for simple installation.

No. 6370ZN-20

Pull-stud size 20 for M16 engagement screw

Hardened, for clamping modules size 20.



Order no.	Size	dia. DN	dia. D1	dia. D2	H	H1	M	T	Weight [g]
554939	20	32,0	25	16	28	23	-	5	85
554940	20	32,0	25	16	28	23	-	5	85
554941	20	31,7	25	16	28	23	-	5	85
303172	20	31,7	-	-	-	-	M 8	-	110

Design:

Order no. 554939: zero point pull-stud, order no. 554940: timing pull-stud, order no. 554941: undersize pull-stud, order no. 303172: protection pull-stud

Note:

The timing pull-stud has an additional alignment bore, which can optionally be used for simple installation.

On request:

Protection pull-stud made of plastic.

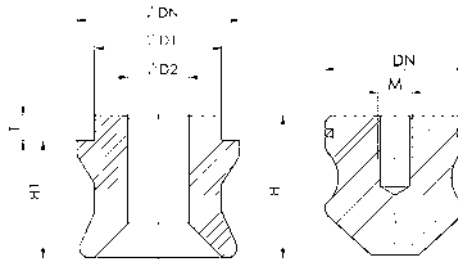

CAD



No. 6370ZNR-20

Pull-stud size 20 for M16 engagement screw with reduced fitting collar

Hardened, for clamping modules size 20.



Order no.	Size	dia. DN	dia. D1	dia. D2	H	H1	M	T	Weight [g]
562768	20	32,0	24	16	28	23	-	5	83
562769	20	32,0	24	16	28	23	-	5	83
562771	20	31,7	24	16	28	23	-	5	83
303172	20	31,7	-	-	-	-	M 8	-	110

Design:

Order no. 562768: zero point pull-stud, order no. 562769: timing pull-stud, order no. 562771: undersize pull-stud, order no. 303172: protection pull-stud

Application:

For clamping in a fitting hole with a reduced diameter e.g. before heat treatment of a workpiece. After the boring out the hole, the respective standard pull-stud can be used.

On request:

Protection pull-stud made of plastic.

CAD



No. 6370ZN-40

Pull-stud size 40 for M16 engagement screw

Hardened, for clamping modules size 40.



Order no.	Size	dia. DN	dia. D1	dia. D2	H	H1	M	T	Weight [g]
303180	40	40,0	25	16	34	29	-	5	180
303198	40	40,0	25	16	34	29	-	5	180
303206	40	39,7	25	16	34	29	-	5	180
303214	40	39,7	-	-	-	-	M 8	-	180

Design:

Order no. 303180: zero point pull-stud, order no. 303198: timing pull-stud, order no. 303206: undersize pull-stud, order no. 303214: protection pull-stud

Note:

The timing pull-stud has an additional alignment bore, which can optionally be used for simple installation.

On request:

Protection pull-stud made of plastic.

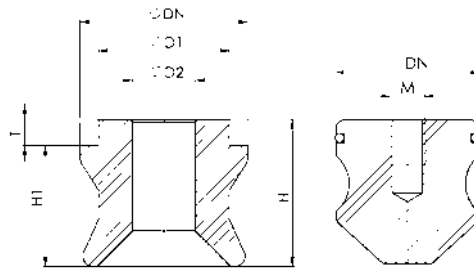

No. 6370ZN-40

Pull-stud size 40 for M18 engagement screw

Hardened, for clamping modules size 40.



Order no.	Size	dia. DN	dia. D1	dia. D2	H	H1	M	T	Weight [g]
554942	40	40,0	30	18	34	29	-	5	170
554943	40	40,0	30	18	34	29	-	5	170
554944	40	39,7	30	18	34	29	-	5	170
303214	40	39,7	-	-	-	-	M 8	-	180

Design:

Order no. 554942: zero point pull-stud, order no. 554943: timing pull-stud, order no. 554944: undersize pull-stud, order no. 303214: protection pull-stud

Note:

The timing pull-stud has an additional alignment bore, which can optionally be used for simple installation.

On request:

Protection pull-stud made of plastic.

No. 6370ZNS-001

Engagement screw

Strength class 12.9.



Order no.	Size	Holding force [kN]	L	L1	M	SW	TORX	Weight [g]
306092	5	8,5	25	3,4	M6	5	-	10
554926	5	13,0	29	3,4	M8	-	T30	13
303578	10	17,0	37	6,0	M8	6	-	25
554927	10	25,0	41	6,0	M10	-	T45	32
559120	20	25,0	54	9,0	M10	8	-	63
303222	20	43,0	54	9,0	M12	8	-	70
554928	20	55,0	63	9,5	M16	-	T60	125
303230	40	75,0	69	10,0	M16	14	-	130
554929	40	105,0	73	11,0	M18	-	T70	195

On request:

Engagement screws in various lengths and materials (e.g. STAINLESS STEEL).

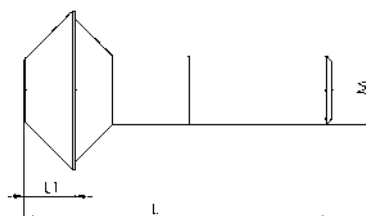

Subject to technical alterations.

Dimensions for machining pull-stud mountings

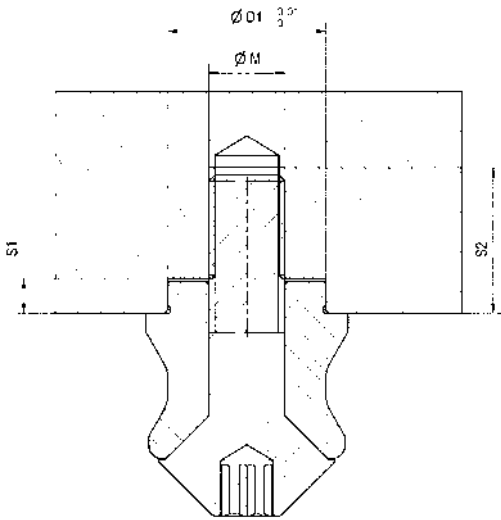

Size	$\varnothing D1$	$\varnothing M$	S1	S2	suitable pull-stud Order-no.	suitable engagement screw Order-no.
5	10,00	M6	2,8	12	306019 306035 306050	306092
5	11,00	M8	2,8	17	562192 562193 562194	554926
10	15,00	M8	3,5	16	303610 303636 304519 430280 430306	303578
10	15,00	M10	3,5	20	554936 554937 554938	554927
10	14,50	M8	3,5	16	562748 562750 562751	303578
10	14,50	M10	3,5	20	562755 562757 562759	554927
20	25,00	M10	5,5	23	303149 303156 303164	559120
20	25,00	M12	5,5	23	430322 430348	303222
20	25,00	M16	5,5	32	554939 554940 554941	554928
20	24,00	M12	5,5	23	562761 562764 562766	303222
20	24,00	M16	5,5	32	562768 562769 562771	554928
40	25,00	M16	5,5	30	303180 303198 303206	303230
40	30,00	M18	5,5	35	554942 554943 554944	554929

Figure:

Shown with pull-stud and engagement screw.



Subject to technical alterations.

No. 6370ZNF-10

Pull-stud size 10 for M8 engagement screw without fitting collar

Hardened, for clamping modules size 10.
Suitable for engagement screw 6370ZNSF.



Order no.	Size	dia. DN	dia. D2	H	Weight [g]
562753	10	22	8	16	30

Design:

Order no. 562753: Zero-point pull-stud

Application:

For clamping workpieces in a threaded hole without a fitting collar.
Used only in conjunction with the construction kit system.

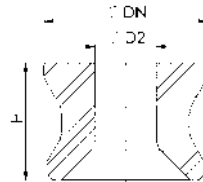

No. 6370ZNF-20

Pull-stud size 20 for M12 engagement screw without fitting collar

Hardened, for clamping modules size 20.
Suitable for engagement screw 6370ZNSF.



Order no.	Size	dia. DN	dia. D2	H	Weight [g]
562767	20	32	12	23	85

Design:

Order no. 562767: Zero-point pull-stud

Application:

For clamping workpieces in a threaded hole without a fitting collar.
Used only in conjunction with the construction kit system.



No. 6370ZNSF

Engagement screw

Strength class 12.9.
Suitable for pull-stud without fitting collar 6370ZNF.

Order no.	Size	Holding force [kN]	M	SW	L	L1	Weight [g]
562861	10	17,0	M8	6	34	6	20
562862	20	43,0	M12	8	47	9	61

On request:

Engagement screws in various lengths and materials (e.g. STAINLESS STEEL).

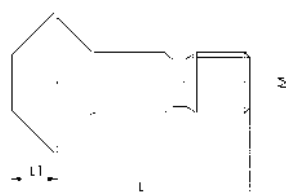

No. 6370ZNM

Pull-stud nut

Strength class 10.
Suitable for pull-stud no. 6370ZN.



Order no.	Size	Holding force [kN]	M	SW	H	Weight [g]
429969	5	8,5	M6	10	6	3
429985	10	17,0	M8	14	8	8
430009	20	43,0	M12	21	14	26
430025	40	75,0	M16	28	17	50

Application:

Pull-stud nut for fastening the pull-stud.

Note:

By gluing the pull-stud nut in the pull-stud with medium-strength adhesive, the nut is kept from turning when loosening the cylinder screw.

- 1 = Pull-stud nut
- 2 = Pull-stud
- 3 = Cylinder screw

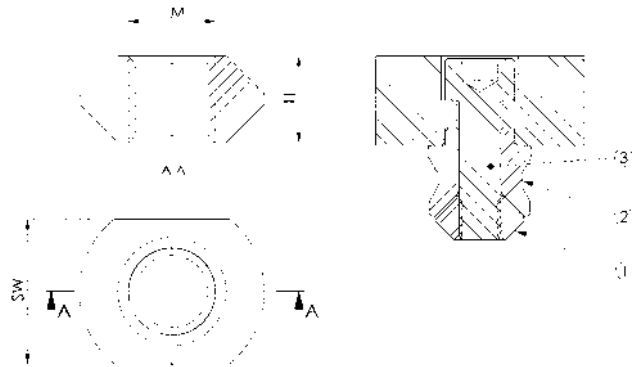

CAD



No. 6370ZNS-002

Horizontal engagement screw

Strength class 12.9.



Order no.	Size	Holding force [kN]	L	L1	M	SW	Weight [g]
303248	20	20	56	10,5	M12	8	100
303255	40	45	73	13,0	M16	10	200

On request:

Horizontal engagement screws in various lengths and materials (e.g. STAINLESS STEEL).

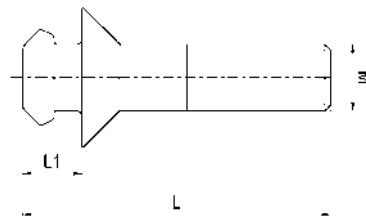

CAD



No. 6370ZNSN

Compensation pull-stud

Hardened, for hydraulic and pneumatic clamping modules.



Order no.	Size	dia. DN	dia. D2	H1	Weight [g]
340059	10	21,8	12,0	16	25
305912	20	31,8	15,5	23	80
426882	40	39,8	20,0	29	160

Note:

The compensation pull-stud is supported by bearings to make it radially mobile and is used when large distance and angle tolerances have to be compensated between the pull-stud holes. The pull-stud only has a holding function and does not absorb a lateral load.

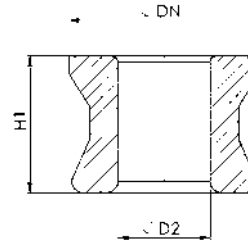

No. 6370ZNSSN

Engagement screw

Strength class 12.9.

Suitable for compensation pull-stud no. 6370ZNSN.



Order no.	Size	Holding force [kN]	dia. D2	L	L1	L2	L3	M	SW	Weight [g]
340034	10	10	11,0	34	6	16,1	11,9	M8	6	24
305938	20	20	13,5	50	9	23,1	17,9	M10	10	55
426908	40	30	17,0	59	10	29,1	19,9	M12	12	100

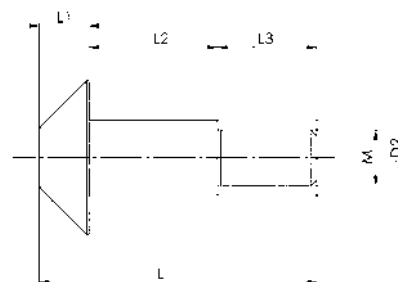

No. 6370ZA

Protective shield

Not burnished, for engagement screw No. 6370ZNSA.



Order no.	Size	dia. D	dia. D1	dia. D2	HA	T	Weight [g]
422345	10	50	15	8,5	7	3	100
422360	20	76	25	12,5	10	5	340
422386	40	112	25	16,8	15	5	1130

Application:

The protective shield is used when through-holes must be set in the area of the module cover. As a result, the module cover is protected from damage.



No. 6370ZNSA

Engagement screw for protective shield

Strength class 12.9.



Order no.	Size	Holding force [kN]	L	L1	M	SW	Weight [g]
422402	10	17	44	6	M8	6	33
422428	20	43	64	9	M12	8	80
422444	40	75	84	10	M16	14	145

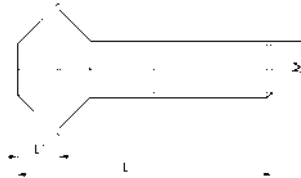

No. 6214RM-250-04

Actuating pin

Not hardened, for mechanical clamping modules 6214RM-250 and 6214RM-251.



Order no.	Size	dia. D	L	M	Weight [g]
561391	250	9,5	20	M3	13

Application:

The extended actuating pin is used for higher interchangeable pallets.

Note:

The actuating pin in the 6214RM-250 and 6214RM-251 clamping modules can be replaced by the extended actuating pin.

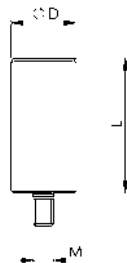

Subject to technical alterations.

No. 6370ZN-20-029

Puller

For pull-stud size 20.



Order no.	Size	Thread	Weight [g]
526517	20	M10	150

Design:

Aluminium puller is suitable for 20 pull-stud.

Application:

Pull-studs can be simply and quickly removed from the workpiece or fixture. For this purpose, the size 20 puller is mounted on a pin extractor and the pull-studs are pulled out without damaging the mounting bore.

No. 6370ZZ

Positioning pull-stud

Hardened.



Order no.	for clamping modules	dia. D1	dia. DN	H	Weight [g]
306241	5	8	15	48	60
306167	10	12	22	48	85
306183	20 / 1000	16	32	64	225
306209	40	20	40	82	455

Application:

The positioning nipple makes all of the surface-mounted modules easier to align. It can be clamped directly in the machine spindle, thus achieving the desired gauges when the machine is traversed.

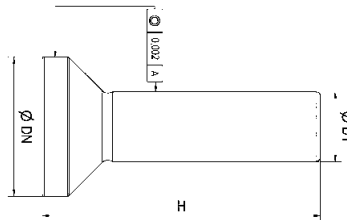

No. 6203ZNA-150

Alignment tool K02 for timing pull-stud

Suitable for order no. 427328.



Order no.	Size	Weight [g]
562804	150	100

Application:

The tool facilitates the alignment of the K02 timing pull-stud.

No. 6203ZMW

Insertion tool

For sizes SP140 and SP150.

NEW!



Order no.	Size	SW	Weight [g]
564843	140	17	53
565395	150	19	70

Application:

Tool for installation of clamping modules 6203SP-140 and 6203SP-150 screw-in version.

No. 6214ZMW-250

Insertion tool

For sizes RP250/251 and RM250/251.



Order no.	Size	SW	Weight [g]
559439	250	12	22

Application:

Installation tool for clamping modules 6214RM-250, 6214RM-251, 6215RP-250 and 6215RP-251 and for clamping sleeves 6214ZN-250-01 and 6214ZN-250-02.

No. 6370ZMW-5

Insertion tool

For sizes KP5 and KH5 in the screw-in version.

NEW!



Order no.	Size	SW [mm]	Weight [g]
564855	5	17	190

Application:

Tool for installation of clamping modules 6103LA-5, 6370EARLA05 and 6370EARHA05 in the screw-in version.

No. 6370ZAS

Cover ring for clamping modules

Material: Aluminium



Order no.	Size	dia. A	S	Weight [g]
552810	10	84	10	80
552811	10.2 / 10.3 / 20	118	11	160
552812	20.3	146	13	260
552813	40	156	13	290

Design:

Cover and protective shield made of aluminium for ZPS clamping modules. These protect the contact surface of the clamping modules and are attached to the outside diameter by a pretensioned O-ring.

Application:

Cover and protective shields are used to protect the contact surface of the ZPS clamping modules from environmental influences.

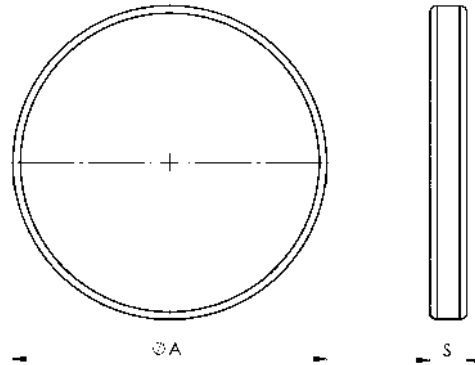

No. 6370ZAR

Cover ring for clamping modules

Stainless steel, self-adhesive.



Order no.	Size	Weight [g]
550281	10.2	4
550282	10.3	4
550283	10	4
550284	20	5
550285	40	6

Design:

Stainless steel, one-side self-adhesive with removable film. Selected sizes are suitable for installation and construction clamping modules.

Application:

Protective cover for clamping modules prevents build-up of dirt and chips.

Note:

Not suitable for clamping module with indexing, square clamping module and heavy-duty module. It must be noted that the adhesive used has only limited suitability for the use of coolant lubricants.



Subject to technical alterations.

No. 6206ZS

Cover caps for clamping module

Material: Polyethylene

Order no.	Packaging unit [St]	Weight [g]
553995	8	3

Application:

Cover and protective caps for the mounting screws of the KP5.3 clamping modules.



No. 6204ZS-01

Cover caps for clamping module

Material: polyethylene

Order no.	Packaging unit [St]	Weight [g]
428664	10	4

Application:

Cover and protective caps for mounting screws of the KH10.2, KP10.3, KP20.3 clamping modules.



No. 6204ZS-02

Cover caps for clamping pallets

Material: polyethylene

Order no.	Size	Packaging unit [St]	Weight [g]
430165	M12	12	15
430181	M16	12	15

Application:

Cover and protective cap for cylinder and positioning boreholes in clamping stations.



No. 6376Z

Adapter set for pull-stud size 10

Supply scope:
 - 1 Adapter sleeve
 - 1 Positioning bush

Order no.	dia. D1	dia. D2	S1	H	Weight [g]
430207	25	15	5,5	19	23

Design:

For blind hole thread and clamping rail, see article no. 6376G.
 The threaded sleeve is produced from alloyed heat-treated steel, the adapter ring from case-hardened steel.

Application:

Adapter kit for reducing the locating bore from pull-stud size 20 to size 10.

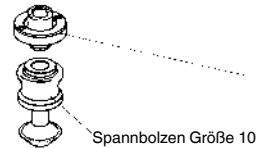
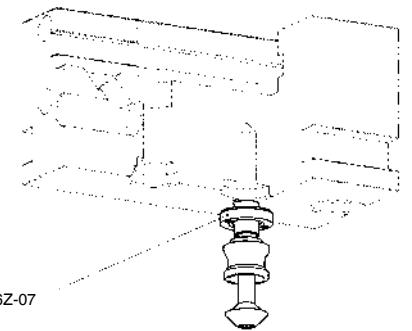
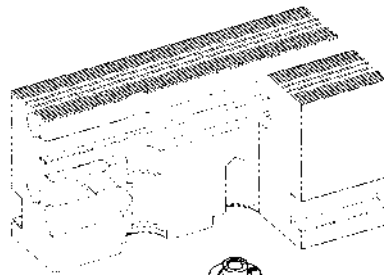
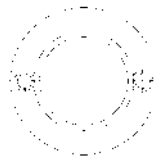
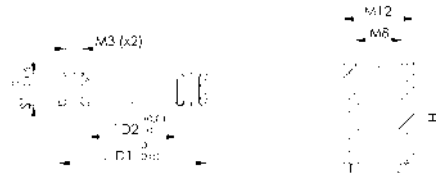

6376Z-07

Spannbolzen Größe 10



Subject to technical alterations.

No. 6376Z

Adapter set for pull-stud size 10

- Supply scope:
- 1 Cylinder head screw
 - 1 Adapter sleeve
 - 1 Positioning bush

Order no.	dia. D	dia. D1	dia. D2	dia. D3	H	S1	Weight [g]
430223	17,5	25	15	12,5	30	5,5	62

Design:

For through-bores in the clamping rail, see Item No. 6376G.
 The threaded sleeve is produced from alloyed heat-treated steel, the adapter ring from case-hardened steel.
 The fastening bolt conforms to strength class 10.9.

Application:

Adapter kit for reducing the locating bore from pull-stud size 20 to size 10.

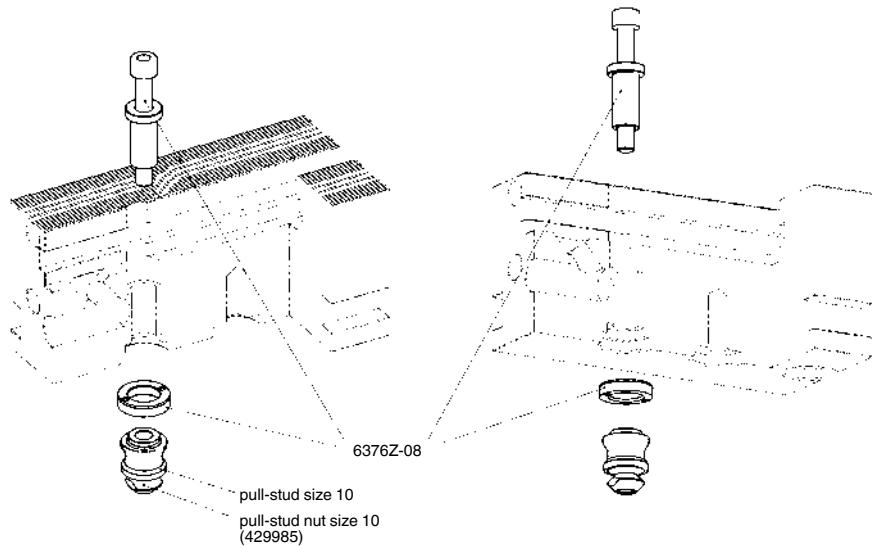
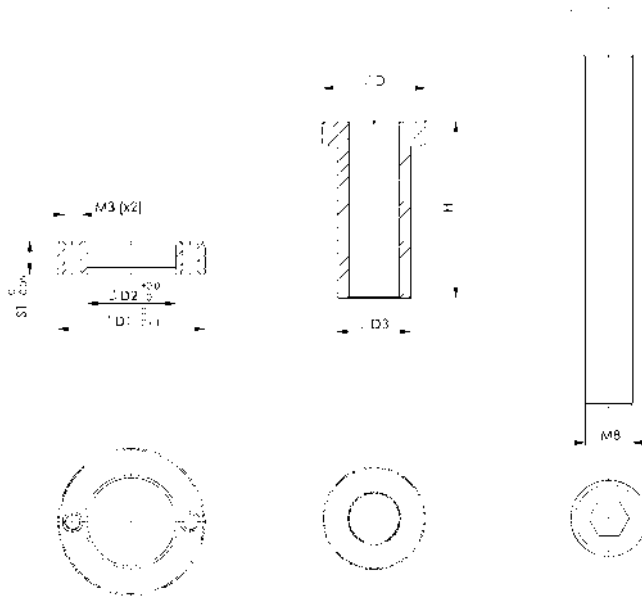

No. 6370ZI

Indexing T-nut

For clamping modules with indexing.
Case-hardened, burnished and ground, incl. fastening bolt.

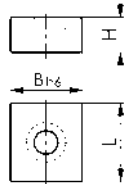

Order no.	Size	B	H	L	Weight [g]
430264	10.2 / 10.3 / 20	8	8	10	6
550288	20.3	10	8	20	15

Application:

Indexing T-nut is used for the precise positioning of workpieces or fixtures on a clamping module with indexing function.

Note:

Order no. 430264 incl. M3 fastening bolt.
Order no. 550288 incl. M4 fastening bolt.

No. 6984-30

Support control, pneumatic

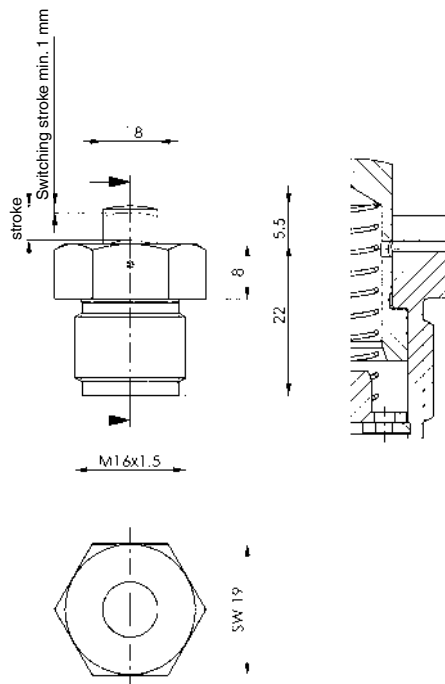
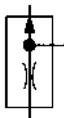

Order no.	Article no.	Stroke max. [mm]	Input pressure [bar]	Spring force min. [N]	Spring force max. [N]	Weight [g]
325217	6984-30	5	1 - 2	1,9	2,6	36

Design:

Housing from hardened and burnished steel. Pistons are tempered, nitrided and ground.
Compression spring from stainless steel.

Application:

The support control is used in fixtures where a signal indicating a correctly supported workpiece is required to enable machining. Lightweight workpieces should be clamped before being pressurised with compressed air.

Features:

The support control works like a pneumatic back-pressure nozzle. The position is extended from its initial position by a pressure spring. Once applied, the air jet flows through the hollow piston and the radial discharge hole on the support control housing to outside. The discharge hole is sealed as soon as a workpiece is mounted and the piston is pushed downwards by min. 1 mm. The air flow backs up, the internal air pressure rises. The pressure value must be transferred to the control by an appropriate pressure signal converter. The system is relatively insensitive to fine chips.

Note:

The pressure signal converter is not included in the supply scope.
Effective piston surface with closed nozzle = 0.95 cm²
Piston force = piston surface x air pressure + spring force
Reduce the input pressure to 1 bar up to a maximum of 2 bar when the air duct is open, e.g. with a throttle check valve. When the air duct is closed, there is a dynamic pressure of approx. 3 bar.

Installation drawing

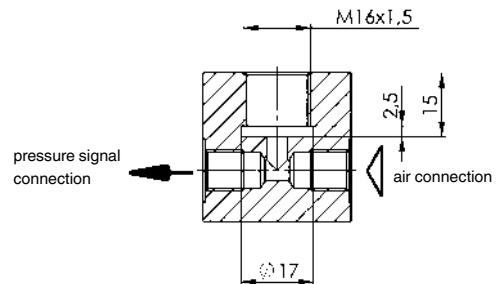

No. 6370ZMMG

Coupling mechanism adapter

Suitable for installation clamping module nos. 6151HA / 6151L.



Order no.	Size	Nominal bore [NW]	A	A1	A2	B	HA	K	dia. N	dia. P	R	T	U	Weight [Kg]
424002	20	5	56	33	18	65	35	13	6 H7	9	G1/8	12	45	0,9
424184	40	5	56	33	18	65	45	13	6 H7	9	G1/8	12	45	1,0

Application:

Couplings are used for loss-free transfer of liquid and gaseous media and are adjusted to the cover height of the installation clamping modules.

Note:

The coupling mechanism and nipple must be guided approx. 2-3 mm before contact with the axial sealing surfaces. The radial position tolerance (+/- 0.2mm) must not be exceeded. The couplings can only be coupled in a depressurised state.

The separating force due to hydraulic pressure between the coupling nipple and mechanism is given by the formula $F [N] = 15.4 \times p [\text{bar}]$ and must be taken into account.

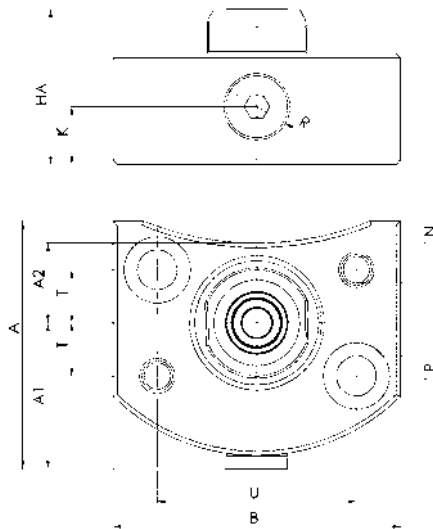

CAD



No. 6370ZMM

Screw-in coupling mechanism

Max. operating pressure 400 bar.



Order no.	Size	Nominal bore [NW]	A	dia. B	C	G	K	dia. P	SW	Weight [g]
424267	10	5	M30x1,5	24	19	29,0	7	25	22	74
424200	10.3 / 20	5	M30x1,5	24	19	29,0	10	25	22	65
424226	20.3 / 40	5	M30x1,5	24	24	31,5	15	25	22	96

Application:

Couplings are used for loss-free transfer of liquid and gaseous media and are adjusted to the cover height of the installation clamping modules.

Note:

The coupling mechanism and nipple must be guided approx. 2-3 mm before contact with the axial sealing surfaces. The radial position tolerance (+/- 0.2 mm) must not be exceeded. The couplings can only be coupled in a depressurised state. The separating force due to hydraulic pressure between the coupling nipple and mechanism is given by the formula $F [N] = 15.4 \times p [\text{bar}]$ and must be taken into account.

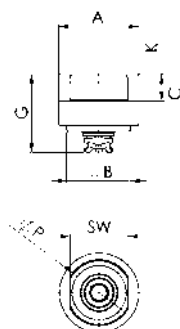

CAD



Subject to technical alterations.

No. 6370ZMNG

Coupling nipple adapter

Suitable for coupling mechanism no. 6370ZMMG / ZMM.



Order no.	Size	Nominal bore [NW]	dia. A	B	C	D	G	K	dia. P	T	U	Weight [g]
424242	10.3 / 20 / 20.3 / 40	5	35	35	60	20	47,5	38,5	5,5	20	40	320

Application:

The coupling nipple adapter is the counterpart to the coupling mechanism and is used in the interchangeable pallet in which the pull-studs are also located. Couplings are used for loss-free transfer of liquid and gaseous media and are adjusted to the height of the installation clamping modules.

Note:

The mounting housings of the two parts must be guided approx. 2-3 mm before contact with the axial sealing surfaces. This function is taken over by the coupling nipple adapter through the centring function. The medium can be passed on at the top over the pipe connection or over the O-ring connection. The radial position tolerance (+/- 0.2 mm) must not be exceeded. The couplings can only be coupled in a depressurised state. The separating force due to hydraulic pressure between the coupling nipple and mechanism is given by the formula $F [N] = 15.4 \times p [\text{bar}]$ and must be taken into account.

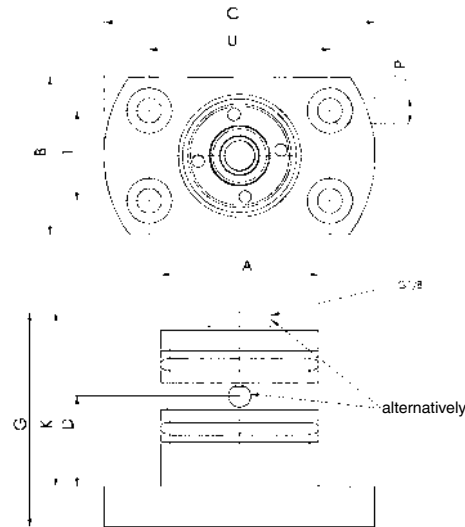

No. 6370ZMN

Screw-in coupling nipple

Max. operating pressure 400 bar.



Order no.	Nominal bore [NW]	A	dia. B	G	dia. H	K	L	P	ØR	Weight [g]
430058	5	M24x1,5	20	27	13,5	14	4,5	18,5	4 x 2,8	56

Application:

Couplings are used for the leakage-free connection of hydraulic oil supplies.

Note:

The coupling mechanism and nipple must be guided approx. 2-3 mm before contact with the axial sealing surfaces. The radial position tolerance (+/- 0.2 mm) must not be exceeded. The couplings can only be coupled in a depressurised state. The separating force due to hydraulic pressure between the coupling nipple and mechanism is given by the formula $F [N] = 15.4 \times p [\text{bar}]$ and must be taken into account.

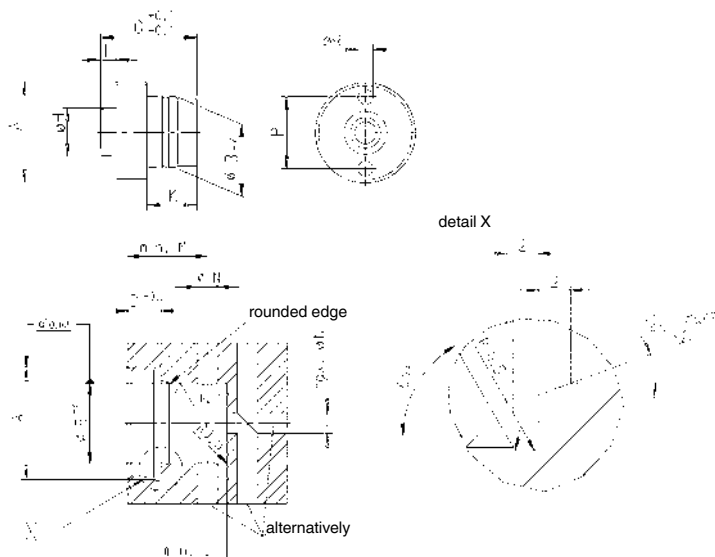

Subject to technical alterations.

No. 6370ZD-004

Air-Hydraulic Pump

Max. operating pressure 60 bar.



Order no.	Pneum. pressure min. [bar]	Pneum. pressure max. [bar]	Oil capacity usable [cm ³]	Flow rate max. [cm ³ /min]	Weight [Kg]
426569	4	6	1000	750	5,9

Design:

Compact, air-pressure-operated hydraulic intensification pump for single-acting circuits. The pump is fitted with an integrated safety valve that regulates the hydraulic output pressure. The safety valve is set in the factory to the max. operating pressure of 60 bar.

The extension element in the oil tank allows the pump to be adjusted horizontally and vertically.

Air connection thread: G1/4

Oil connection thread: G1/4

Application:

The air-hydraulic pump is used for opening for hydraulic clamping modules or hydraulic clamping stations.

Note:

The use of purified, lubricated compressed air is recommended for operation of the pump.

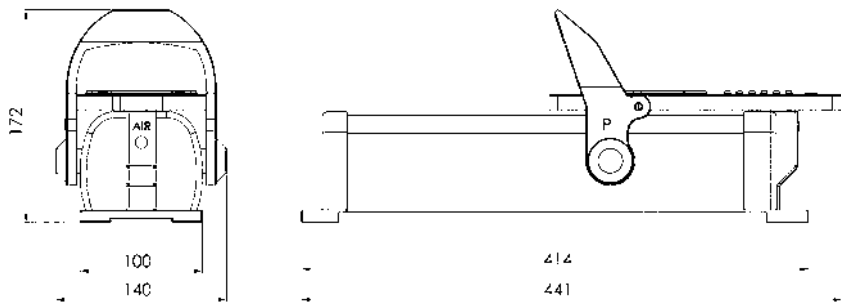

CAD



No. 6370ZD

Pressure intensifier

Max. operating pressure 100 bar.



Order no.	Oil capacity [cm ³]	Flow rate [cm ³ /min]	Rato	max. no. of clamping cylinders	Weight [Kg]
554493	400	400	1 : 10	22 (Typ 20), 9 (Typ 40)	17,4

Design:

Compact, air-pressure-operated pressure intensifier for single-acting hydraulic circuits. With pneumatic control unit for the hydraulic output pressure, pressure gauge and fill level indicator.

Application:

The pressure intensifier is used for opening for hydraulic clamping modules or hydraulic clamping stations.

On request:

- Pressure intensifier with enlarged oil volume

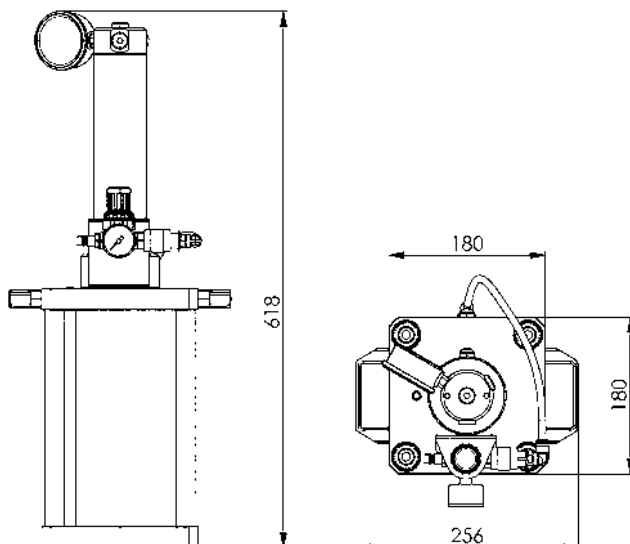

CAD



Subject to technical alterations.

No. 6370ZS-06-2000

Hose set, hydraulic

Max. operating pressure 100 bar.

Order no.	Length	Weight [g]
	[m]	
430082	2	730

Design:

The connection set includes:
 1x hydraulic connecting tube, length 2 m
 2x straight screw pipe connections
 2x straight screw-on fittings
 1x T-screw-on fitting
 1x pressure gauge 0-100 bar
 1x straight female stud coupling
 2x quick coupling sleeves
 2x quick coupling plugs.

Application:

This set is used for the hydraulic connection of extension clamping modules or clamping stations for pressure generators such as pressure intensifiers or air-hydraulic pumps.



Subject to technical alterations.

No. 6370ZR

Pipe fittings, brass

for pipes external Ø 8 mm, internal Ø 4 mm.
Max. operating pressure 100 bar.

Application:

Fittings for piping of surface-mounted clamping modules and flange versions.

Note:

* Article 429936:

Seamless hydraulic pipe, phosphate-coated and lubricated, Ø 8x2 mm, length 2.0 m, made of steel (fully killed cast steel) in accordance with DIN 2391 C normalised, bright-annealed (NBK) cold-drawn.

Order no.	Fig. No.	Connection	Weight [g]
320986	1	G1/4	80
305409	1	G1/8	44
321000	2	G1/4	31
305417	2	G1/8	23
321026	3	G1/4	95
305425	3	G1/8	60
321042	4	-	37
321067	5	-	56
427963	6	G1/8	16
429019	6	G1/4	44
429936	7	*	475

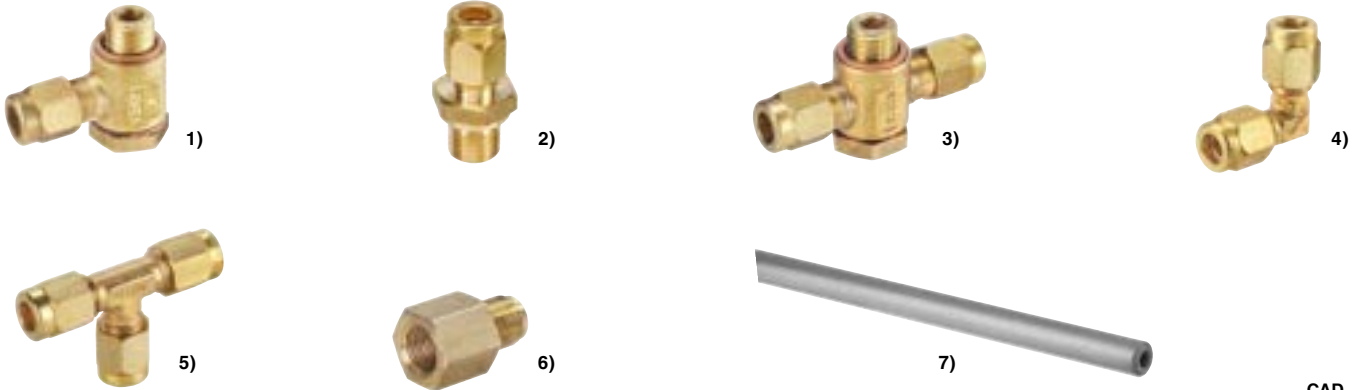

No. 6370ZRA

Adapter with external thread

Max. operating pressure 350 bar.

Order no.	dia. D	G	G1	L	L1	L2	SW	Weight [g]
558045	4	G1/8	G1/8	25	10	10	14	14
558050	4	G1/8	G1/4	28	10	11	19	22

Design:

Adapter with external thread in inches, made of steel, galvanised.

Application:

For adaptation of hydraulic connection components for zero-point clamping systems.

Note:

The Cu sealing rings are not supplied as standard and must be ordered separately.

Form A sealing ring Cu (copper):

G1/8: order no. 69815

G1/4: order no. 69823

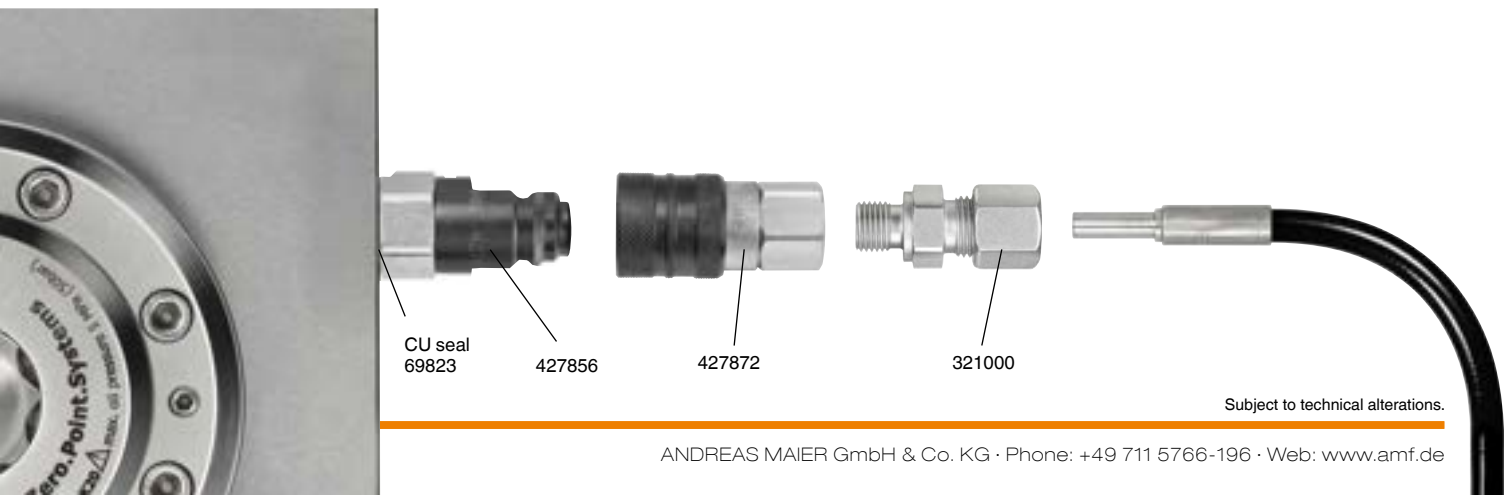
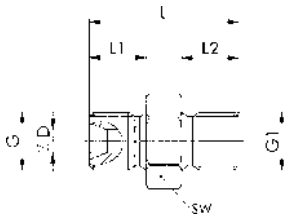

Subject to technical alterations.

No. 6985R

High Pressure Hose

Max. operating pressure dyn. at +50°C 375 bar.

Order no.	Article no.	Bending radius min. [mm]	dia. D [mm]	dia. D1 [mm]	dia. D2 [mm]	L [mm]	Weight [g]
63198	6985R-300	30	9,8	4,8	8	300	65
63206	6985R-500	30	9,8	4,8	8	500	90
63214	6985R-800	30	9,8	4,8	8	800	120
63222	6985R-1250	30	9,8	4,8	8	1250	180
63230	6985R-2000	30	9,8	4,8	8	2000	265
63248	6985R-3000	30	9,8	4,8	8	3000	380

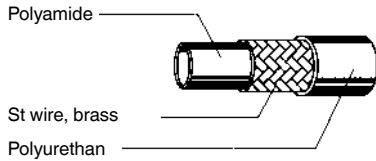

Design:

Steel fitting, galvanized and passivated. Hose of synthetic material with high tensile brassed steel-wire braid.

Application:

Insert hose and tighten with 1/4 turn maximum.

Note:

We recommend only using the 3-metre long high pressure hose for double-acting elements. These high pressure hoses can be used directly in pipe connections. The maximum service life must be 6 years but the maximum service life must not exceed 10 years. Date of manufacture (quarter/year) is printed on the hose. Serviceability must be assessed in accordance with established inspection criteria. See DIN 20066, section 5 for further details.

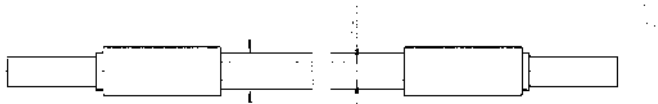

No. 6370ZS-08

Hydraulic tube

Max. operating pressure dyn. at +50°C 375 bar.

Order no.	Test pressure [bar]	Bending radius min. [mm]	dia. D	dia. D1	G	G1	L	SW	SW1	Weight [g]
558008	1200	20	5	2	G1/8	G1/4	1000	14	19	20

Design:

Steel fitting, galvanized and passivated. Hose of synthetic material with high tensile brassed steel-wire braid.

Application:

Connection and installation of hydraulic zero-point clamping systems under reduced space conditions or small bending radius.

Note:

The period of use of a hydraulic hose, including any storage period, should not exceed six years. The serviceability must be assessed according to established inspection criteria. See DIN 20066, section 5 for further details.

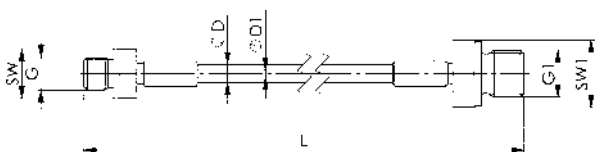

No. 6370ZSK

Quick coupling „flat-face“ G1/8

Max. operating pressure 420 bar.

Order no.	Nominal bore [NW]	Nominal flow [l/min]	SW [mm]	Weight [g]
558043	4	3	17	38
558044	4	3	19	72

Application:

Since the clamping modules after blow-off of the opening pressure are mechanically locked, the hose is then uncoupled by means of the quick couplings. The advantage of this is that there are no interfering lines.

Note:

Flat-sealing quick coupling with internal thread G1/8.

Adapters from internal to external thread and copper sealing rings are not supplied as standard and must be ordered separately.

G1/8 to G1/8: Order no. 558045

G1/8 to G1/4: Order no. 558050

Copper sealing ring: Order no. 69815

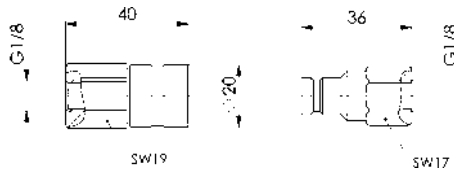

558044 sleeve

558043 connector

CAD



No. 6370ZSK

Quick coupling „flat-face“ G1/4

Zinc-plated.

Max. operating pressure 300 bar.

Order no.	Nominal bore [NW]	Nominal flow [l/min]	SW [mm]	Weight [g]
427856	6	12	22	100
427872	6	12	22	170

Application:

Since the clamping modules after blow-off of the opening pressure are mechanically locked, the hose is then uncoupled by means of the quick couplings. The advantage of this is that there are no interfering lines.

Note:

Flat-sealing quick coupling with internal thread G1/4. A threaded stud is supplied for external thread G1/4. A copper sealing ring is supplied as standard.

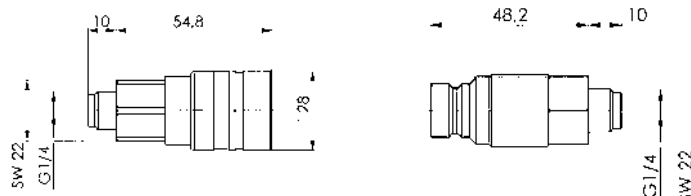

427872 sleeve

427856 connector

CAD



Subject to technical alterations.

No. 6370ZSK-11

Coupling connector

Brass.

NEW!



Order no.	Nominal bore [NW]	Nominal flow [l/min]	SW	Weight [g]
565059	7	1260	17	23

Application:

Coupling connectors are used for the pneumatic connection to pressure generators, e.g. the pressure intensifier and are suitable for coupler sockets, size 4 (NW7).

Note:

The sealing rings are not supplied as standard and must be ordered separately.
G1/4: Order no. 69823

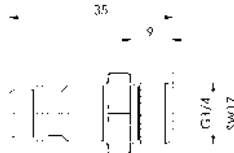

No. 6988

Manifold

Order no.	Article no.	Operating pressure [bar]	NG	A	B	C	R	Oil connections	Weight [g]
68825	6988-G1/4x4	400	6	-	50	30	G1/4	4	480
68817	6988-G1/4x6	400	6	200	50	30	G1/4	6	2025
560021	6988-G1/4x10	400	6	200	50	30	G1/4	10	1980

Design:

Housing from steel, burnished.



68825

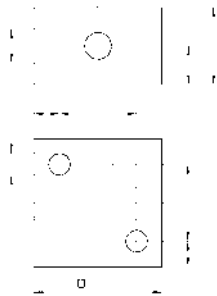

68817

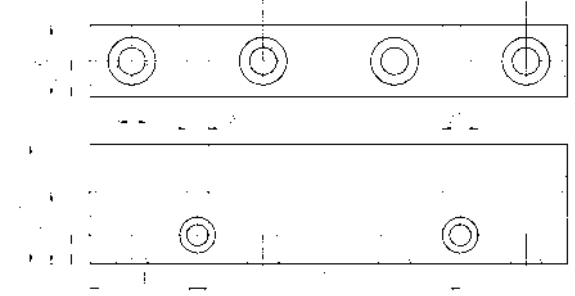

560021

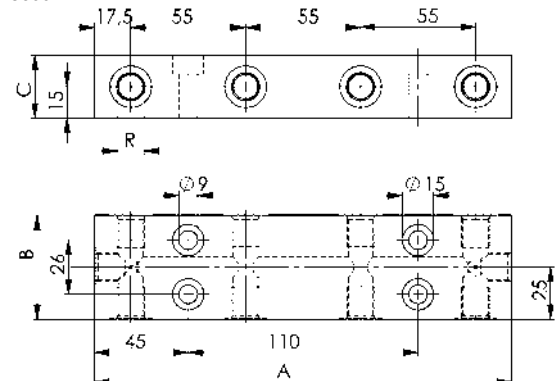

Subject to technical alterations.

No. 6370ZVL-005

Pneumatic pressure booster



Order no.	Input pressure [bar]	Output pressure [bar]	Connection	Weight [Kg]
427088	2,5-8	4,5-10	G1/4	1,5

Design:

Pressure booster with possibility to adjust the pneumatic output pressure, incl. accessories such as pressure gauge kit, sound absorbers and flange mounting.

Application:

For strengthening the operating pressure with pneumatic clamping modules and compensation for pressure fluctuations in the supply line.

Note:

The pressure booster can be mounted in every installation position. For operation, filtered (40µm), unlubricated compressed air as per ISO 8573-1 is required. The pressure booster is suitable for ambient temperatures of +5 – +60 °C.

The accessories for the pressure booster still need to be installed.

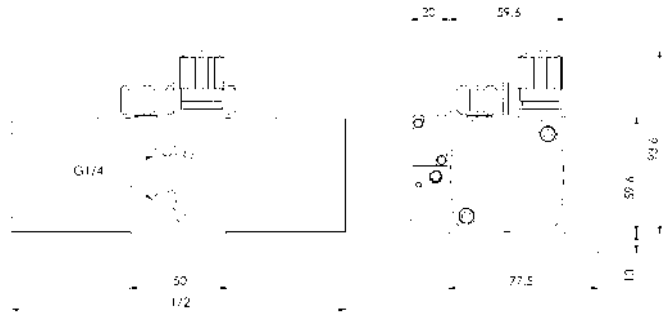

No. 6370ZVL-004

Pneumatic pressure booster set

Order no.	Input pressure [bar]	Output pressure [bar]	Connection	Weight [Kg]
421396	2,5-8	4,5-10	G1/4	2,5

Design:

Pressure intensifier group with possibility to adjust the pneumatic output pressure, incl. manometer construction kit, sound absorbers, flange mounting, pressure control valve, manual direction valve, coupling plug, connections and plastic tube.

Application:

For strengthening the operating pressure with pneumatic clamping modules and compensation for pressure fluctuations in the supply line.

Note:

The pressure intensifier can be mounted in every installation position. For operation, filtered (40µm), unlubricated compressed air as per ISO 8573-1 is required. The pressure intensifier sub-assembly is suitable for ambient temperatures of +5 – +60 °C.



No. 6370ZSK

Quick fitting coupling, pneumatic

Max. operating pressure 12 bar.



Order no.	Nominal bore [NW]	Nominal flow [l/min]	SW [mm]	Weight [g]
430041	4,2	563	14	23
430066	5,0	563	14	27

Application:

This pneumatic quick-release coupling is particularly suitable for use in the AMF zero-point clamping technology of the zero-point system.

Note:

Sleeve with Order no. 430066:
Coupling valve with venting function and check valve. External thread G1/8.

Connector with Order no. 430041:
Dirt and shaving-repellent coupling connector with borehole for forced venting of the clamping station, fixture or zero-point clamping module. External thread G1/8.
Protective cap 6370ZSS-04 is supplied as standard. The sealing rings are not supplied as standard.

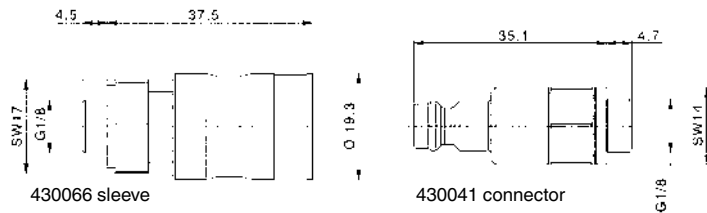

No. 6370ZSS-04

Protective cap

Material: TPS.
For 6370ZSK connectors (quick coupling)

NEW!



Order no.	Packaging unit [St]	Weight [g]
563925	5	5

Application:

Protective cap for the connector on the pneumatic quick coupling with Order no. 430041.

Note:

To protect the connector from contamination.

No. 6370ZS-07

Hose, pneumatic

Polyurethane, outside calibrated.
Max. operating pressure 10 bar.



Order no.	Hose dia. [mm]	Length [m]	Weight [g]
430140	8	3	100

Application:

Hoses are used for the pneumatic connection of extension clamping modules or clamping stations.

No. 6370ZR-02

Push-in fittings, pneumatic

Max. operating pressure 12 bar.
For hose diameter 8 mm.



Order no.	Fig. No.	Connection	Weight [g]
421479	1	G1/8	14
421453	1	G1/4	16
430108	2	G1/8	19
430124	2	G1/4	27

Application:

Screwed connections are used for the pneumatic connection of extension clamping modules or clamping stations.

No. 6370ZSV-01

T-plug connection, pneumatic

Max. operating pressure 14 bar.

NEW!



Order no.	Hose dia. [mm]	Weight [g]
567201	8	16

Application:

T-connectors are used to connect the pneumatic hoses.

No. 6370ZVL-007

Footrest valve, pneumatic

Max. operating pressure 10 bar.



Order no.	Air connection	Weight [g]
477570	G1/4	610

Application:

For controlling pneumatic clamping modules.

Note:

manual Footrest valve
valve function: 3/2 closed, monostable, latching

No. 6370ZSK-08

Air gun valve, pneumatic

Max. operating pressure 10 bar.



Order no.	Nominal bore [NW]	Nominal flow [l/min]	SW	Weight [g]
533075	2,5	240	13	10

Design:

Pneumatic air gun with integrated non-return valve.

Application:

For simple and quick opening of the pneumatic zero point clamping plates. When the air gun is positioned on the valve, the air pressure is released and then held by the non-return valve. Venting is effected by briefly and manually pushing the valve, which then resets under spring force.

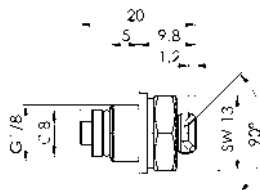

CAD

Subject to technical alterations.



Direct clamping of the workpiece for large aluminium components. Zero-point clamping modules in the work table in conjunction with attachment and intermediate elements of the modular zero-point clamping system enable flexible clamping to be achieved.

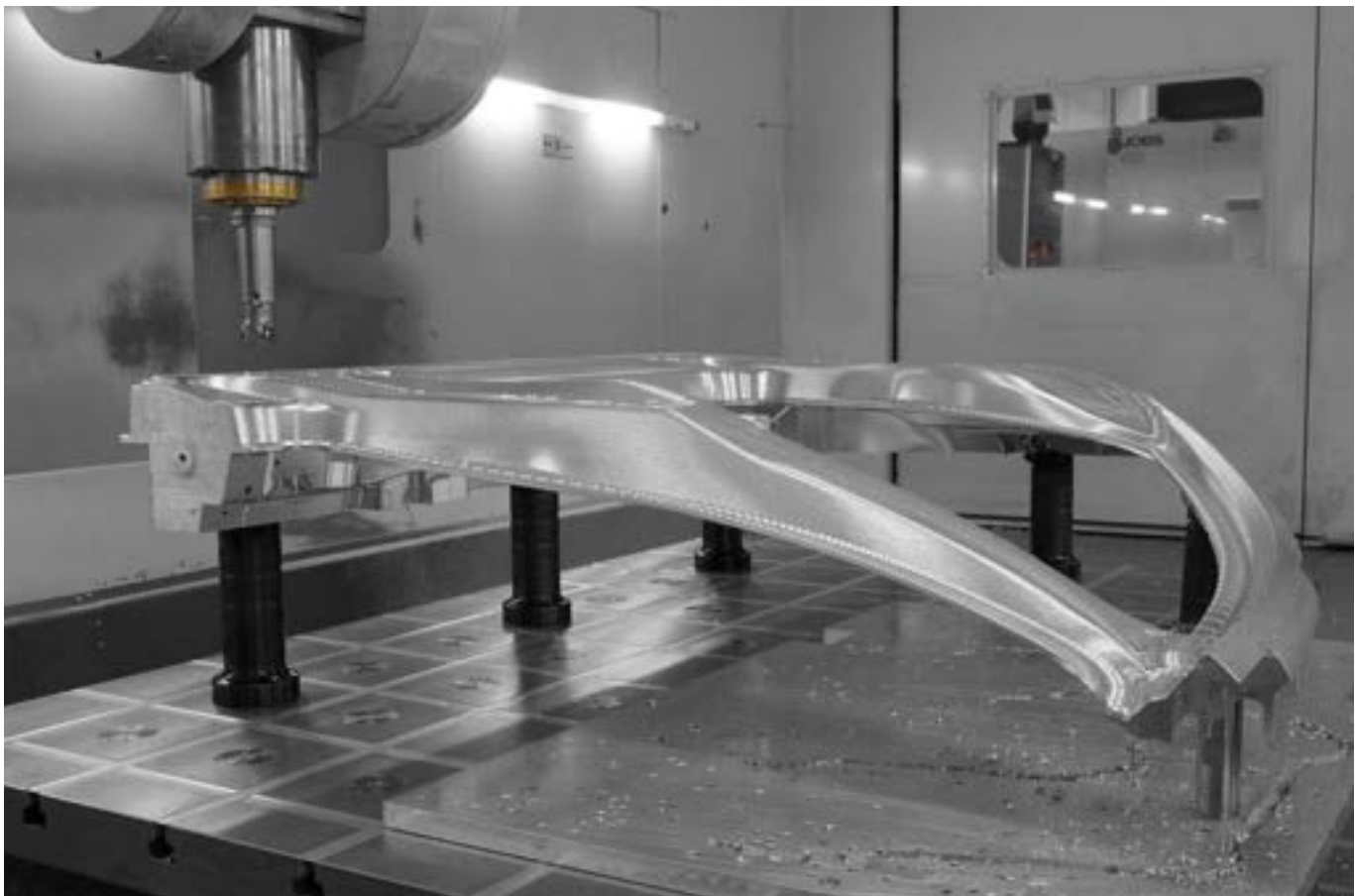



Minimize set-up times with AMF zero-point clamping technology: the workpiece is clamped in just a few simple steps for five-sided machining.

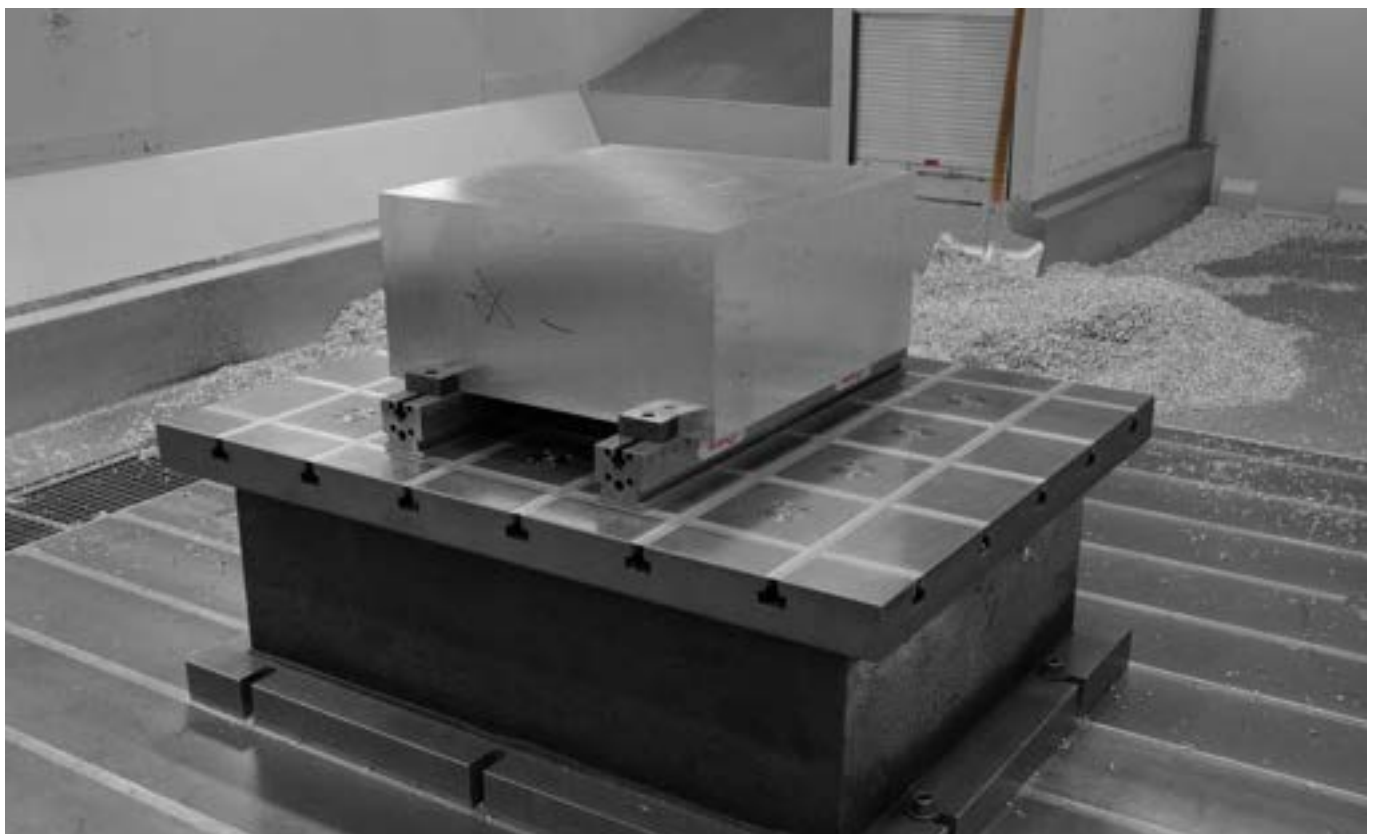

The AMF zero-point clamping system provides the greatest possible flexibility. The AMF multiple clamping system can be clamped simply using zero-point clamping technology and can then be integrated in the production process.



The zero point clamping towers are flexibly adapted to the respective workpiece by simply repositioning them.
Colour coding ensures safe, repeatable clamping.



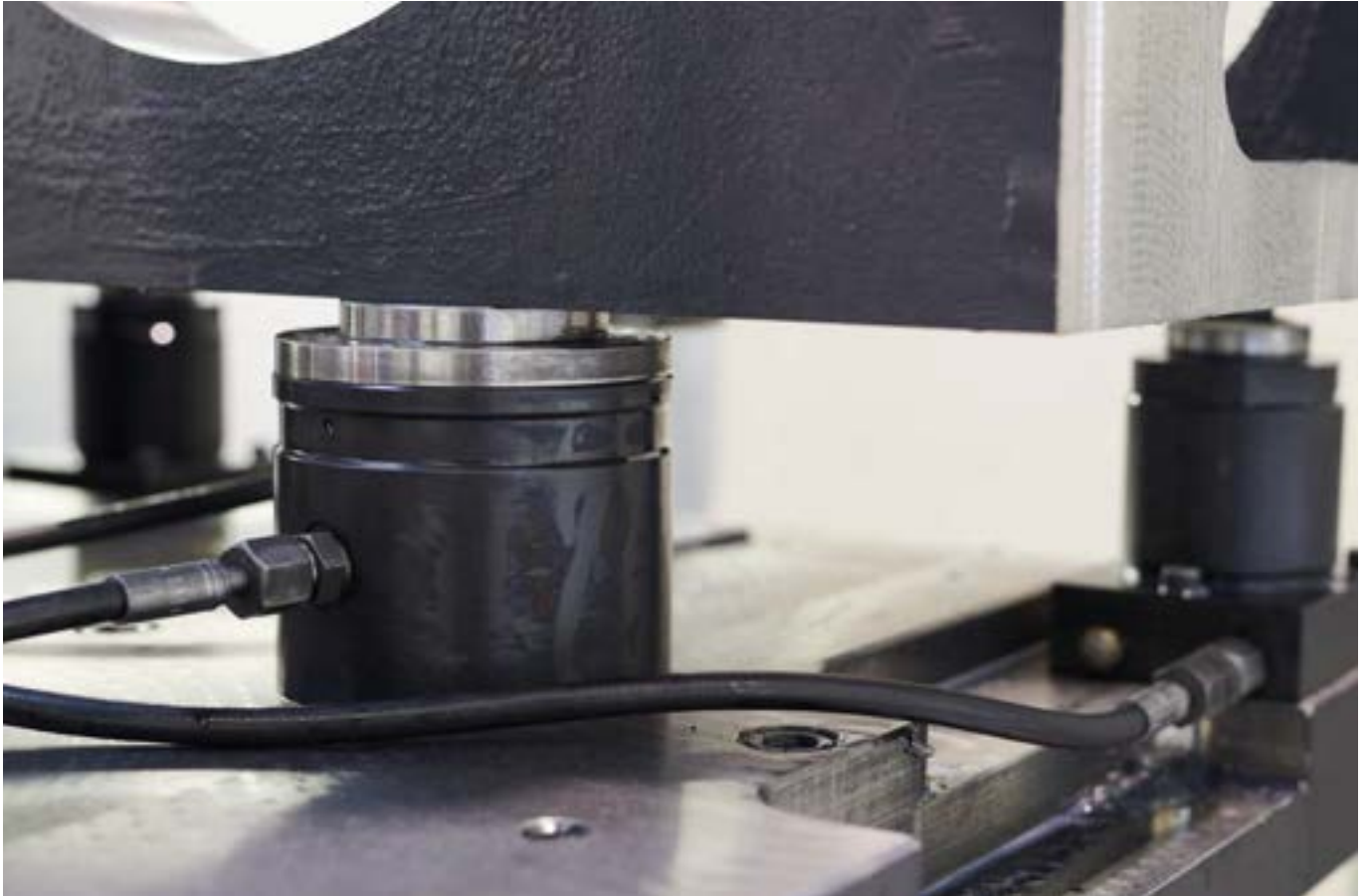

The zero point clamping modules fix and clamp the components directly, without distortion and accessible all around for five-sided machining.



Lifting tables equipped with zero-point clamping technology for deburring the workpieces.
As a result, the complete manufacturing process has been seamlessly optimised with the AMF Zero-Point-System.



Use of various sizes of standard clamping modules in one application.



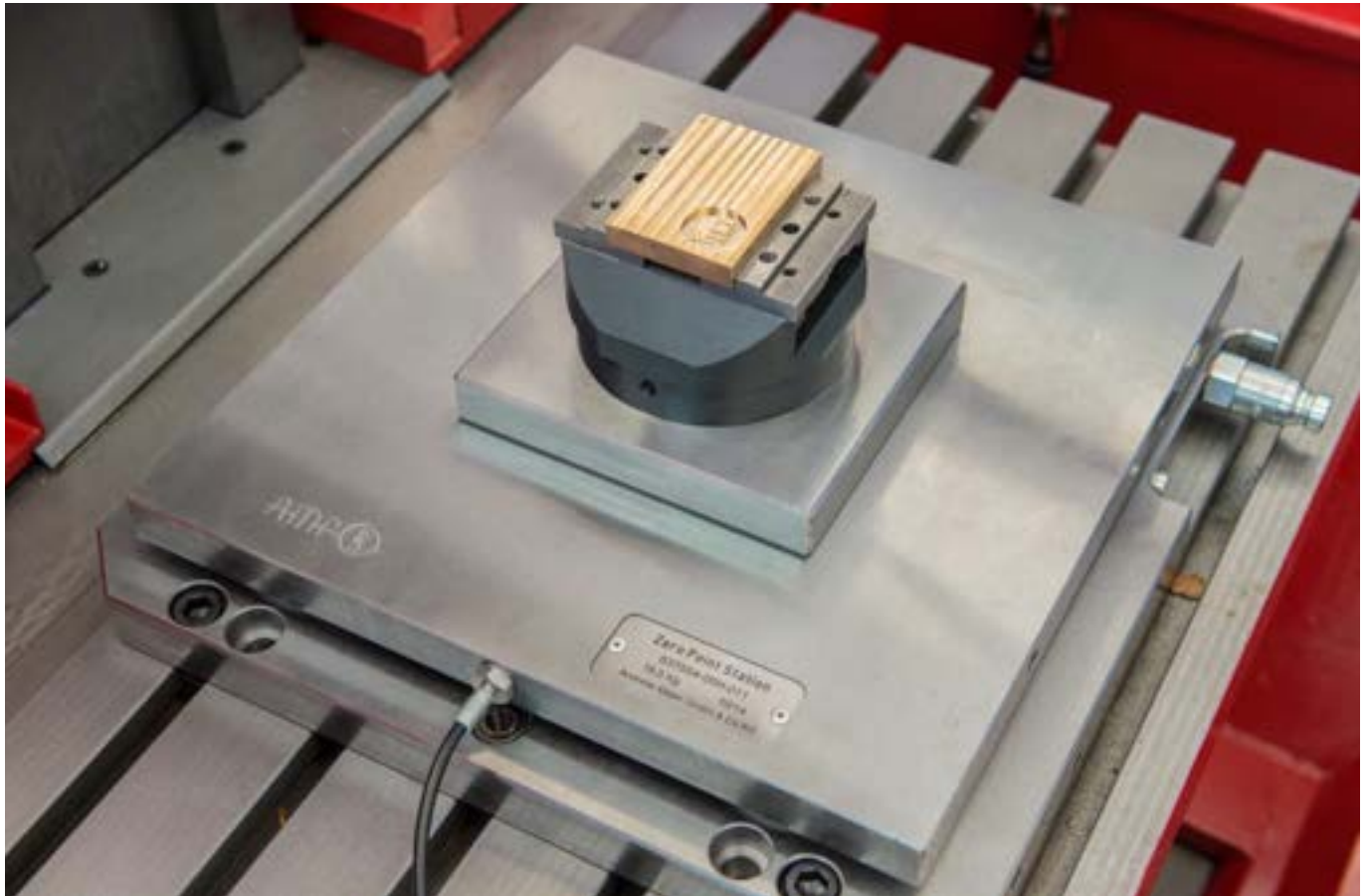

The AMF zero-point system is the standard interface here between various machines. This means that the workpiece can be clamped on the different machine tables in such a way that optimises set-up time regardless of the size.

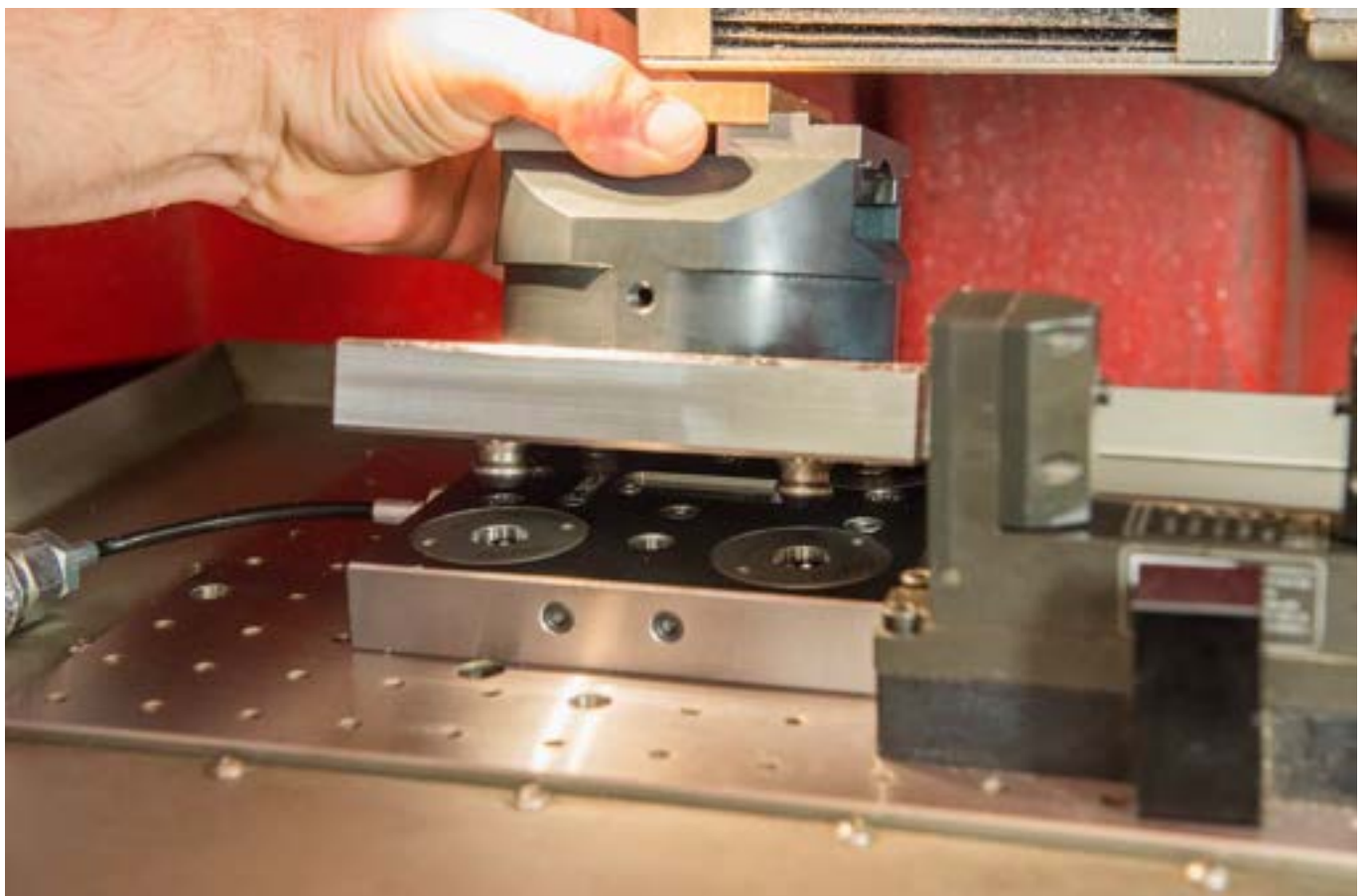

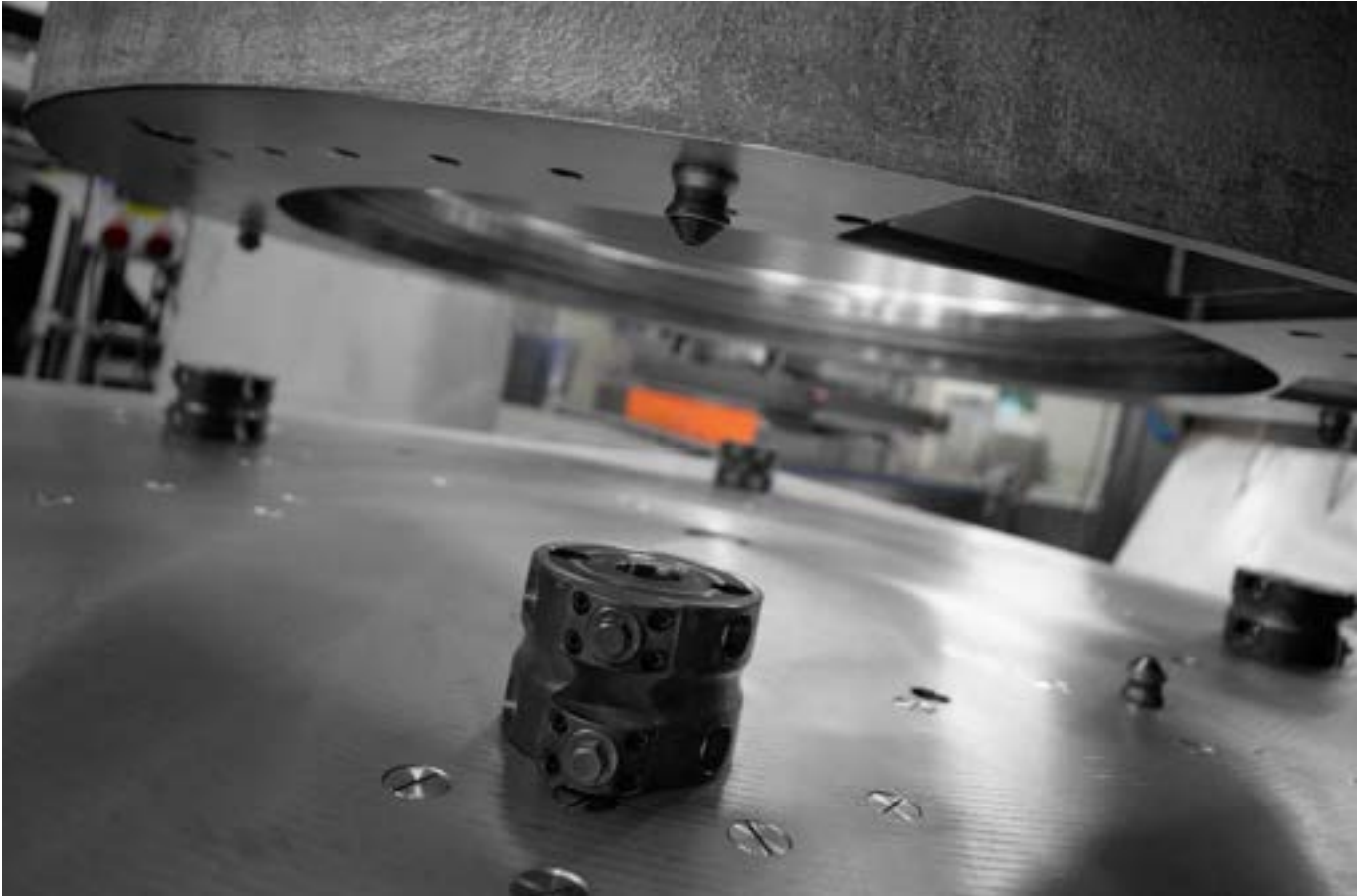

Direct clamping of component by means of mechanical, double clamping modules.



Subject to technical alterations.



Optimisation of set-up times in small-series production by means of variable, direct clamping of the component.
The double clamping modules can be adapted quickly to the different components simply by repositioning.





Modular mechanical zero-point clamping system in tool and mould making.
The different clamping heights required can be easily adjusted using the standardized construction kit system.



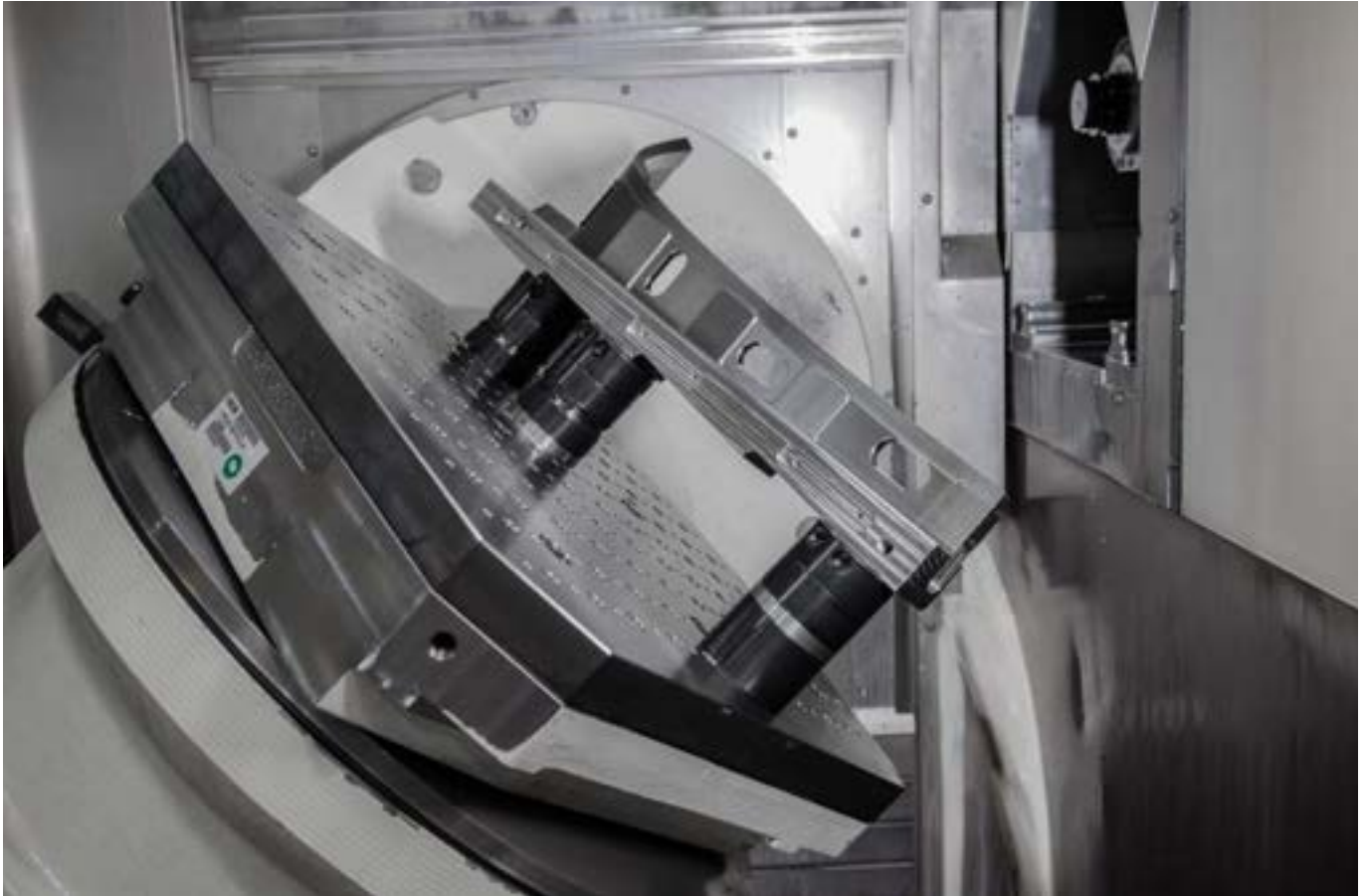

Simple 5-sided machining of workpieces with a complex outer contour. The clamping pillars can be built up with repeatable accuracy by positioning on the perforated grid plate. This enables fast planning and creation of the NC programs.

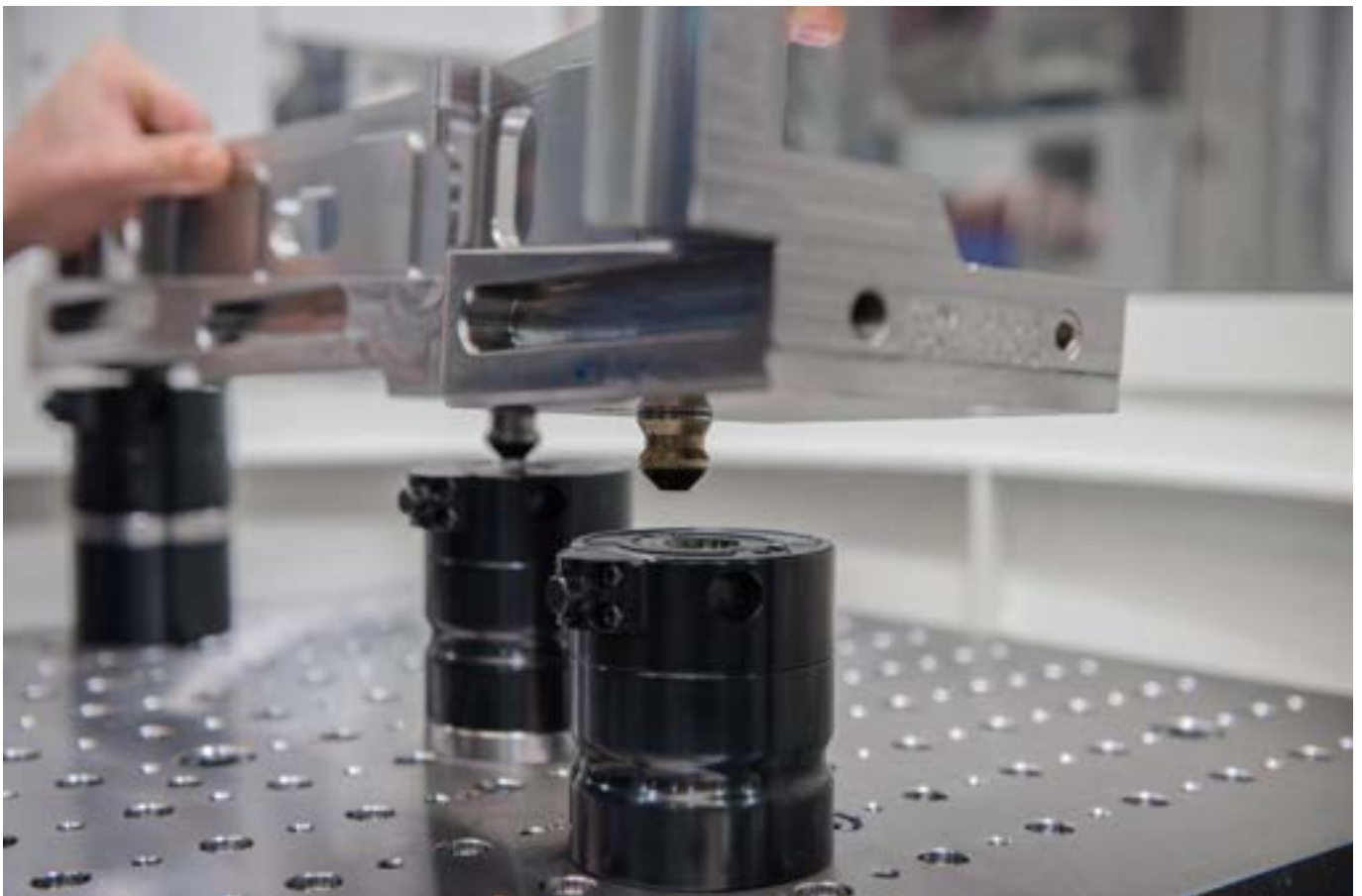



Easy alignment of multiple vices when machining long workpieces.



AMF multiple clamping system in conjunction with the AMF zero-point system.



8-point clamping station for mounting different standard clamping equipment or direct clamping of the workpiece.





Fully automatic loading and clamping of circular blanks during the production of dental implants.

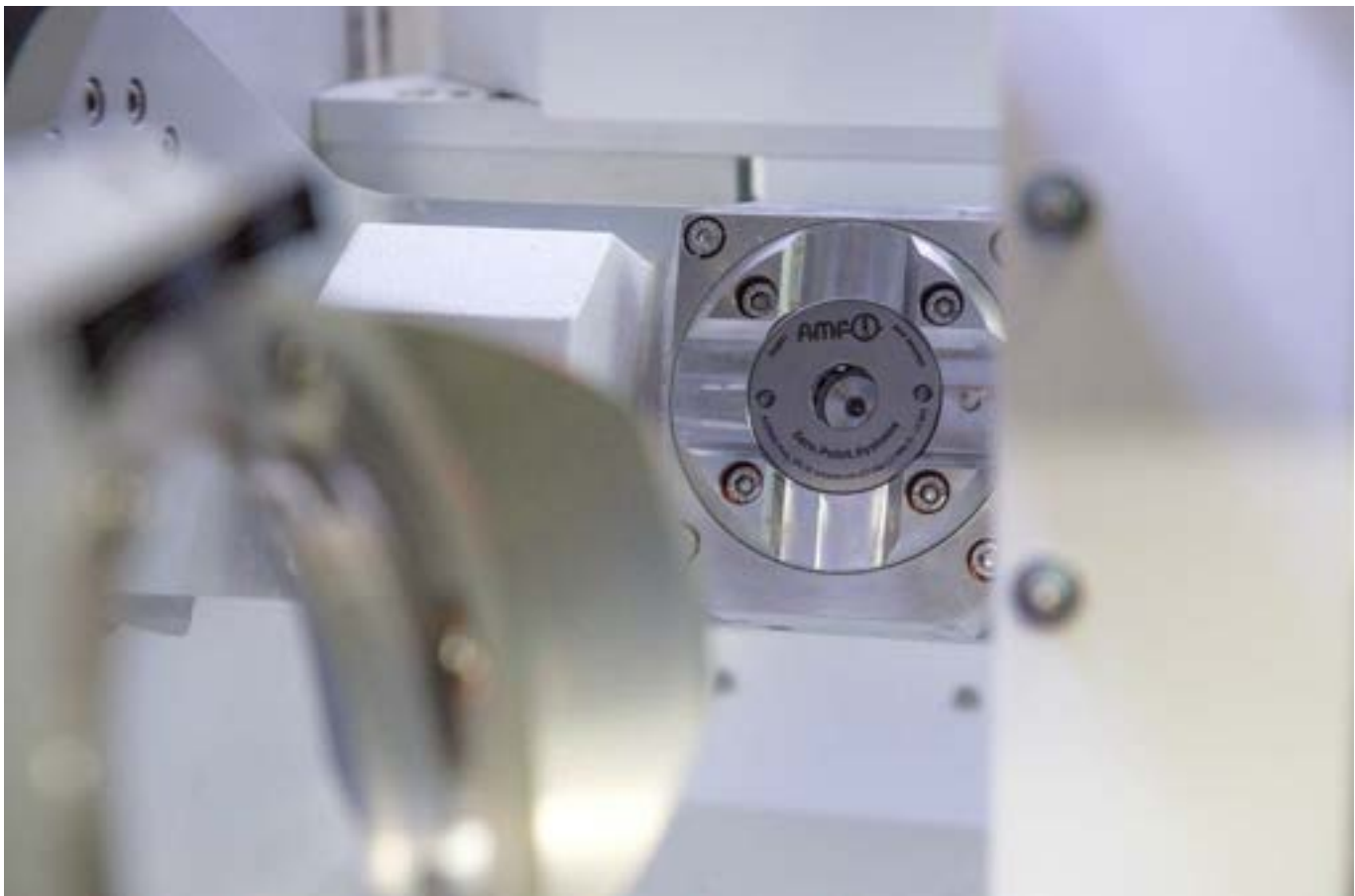



Our zero-point system is the factory standard interface here between the machine table and blank carrier.





AMF-Zero-Point-Systems in additive manufacturing.
The 5-point clamping station enables the substrate plate to be changed quickly on the hybrid machine (SLS / HSM).





The AMF zero-point clamping modules are specially designed for use in additive manufacturing and the associated high temperature influences. They are completely sealed and therefore insensitive to the influences of the metal powder.

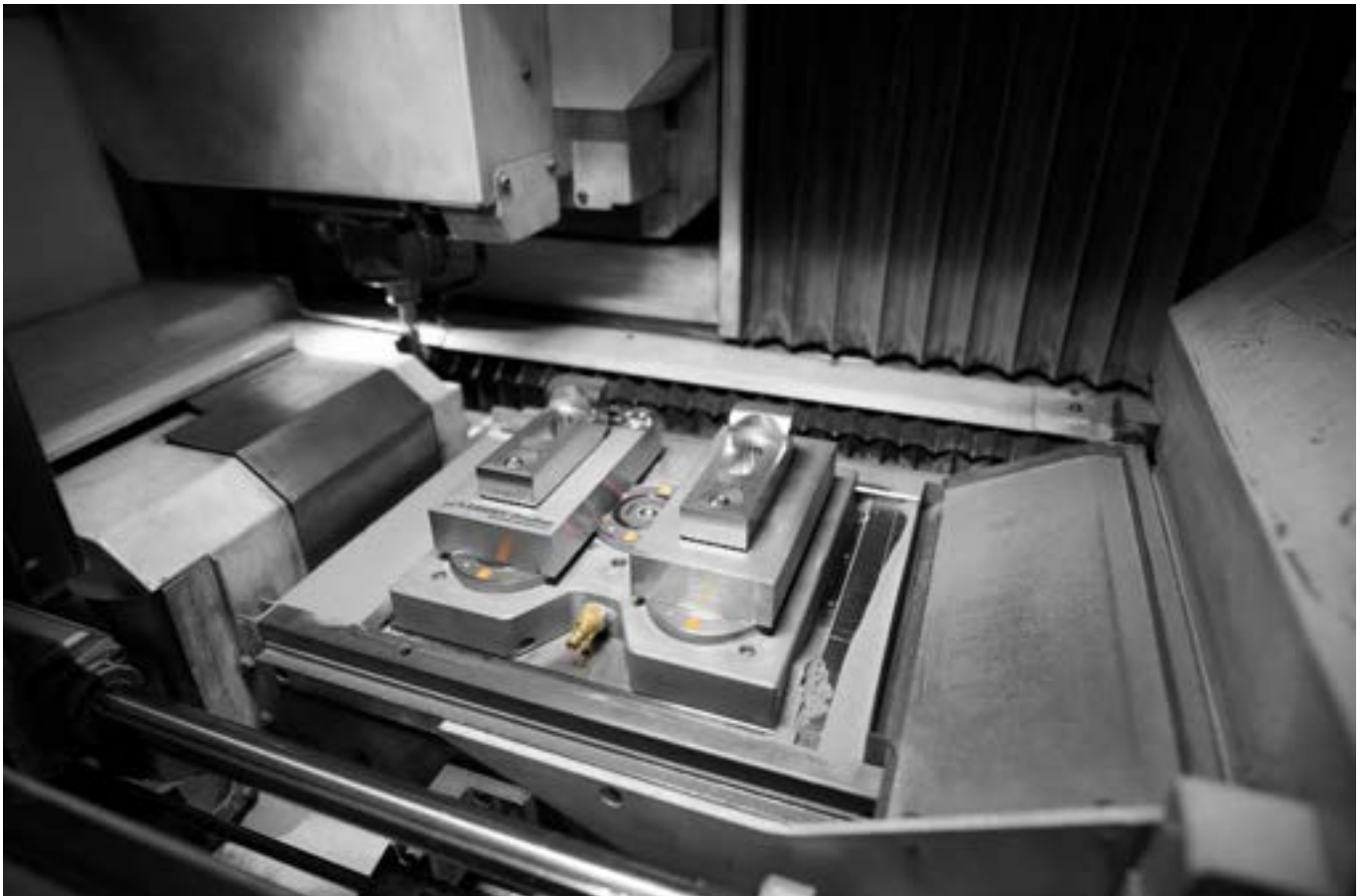



This complete clamping solution combines multiple clamp types in one clamping fixture. (modular clamping system, hydraulic clamping system as well as zero-point clamping technology).

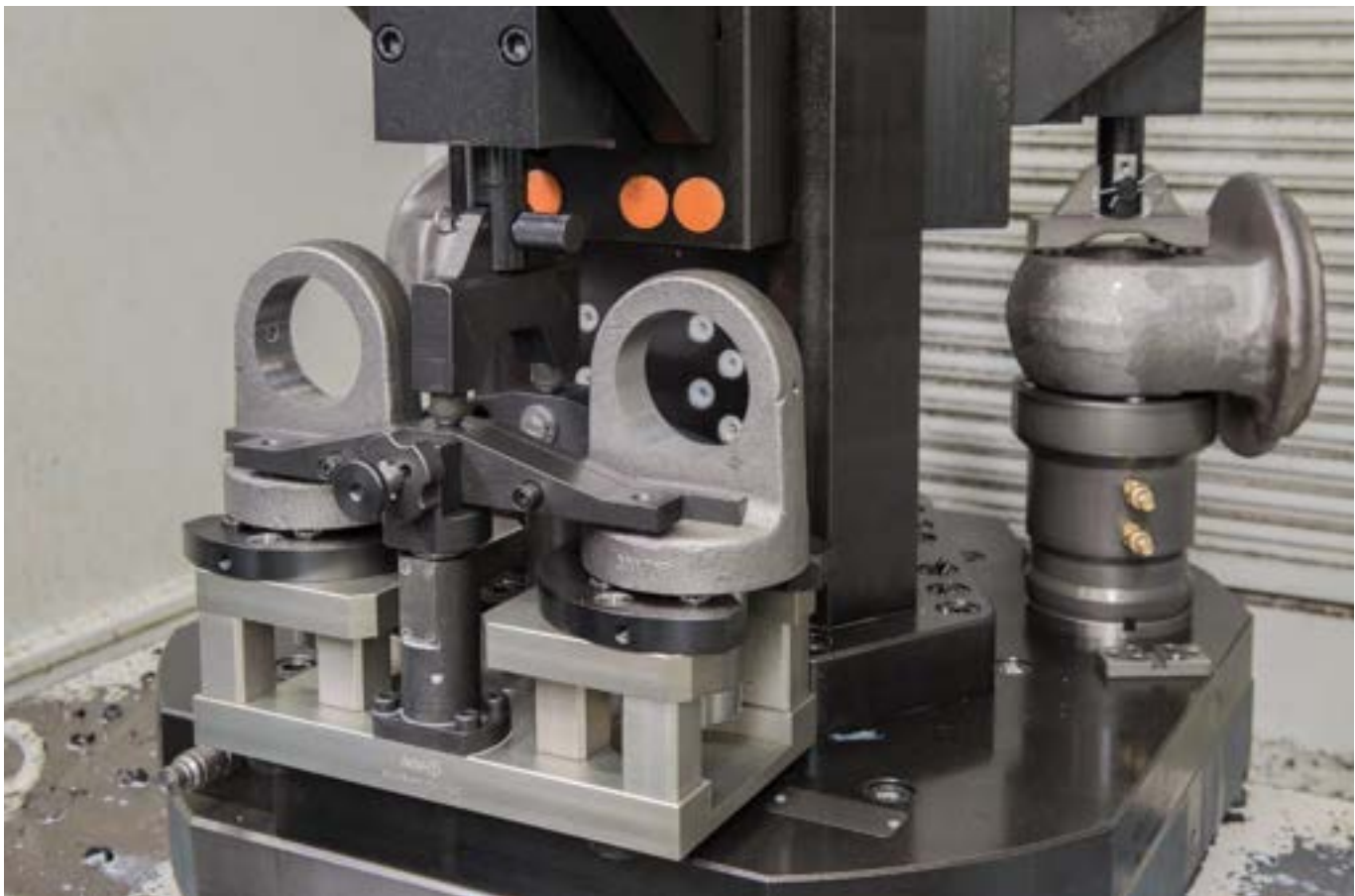

Subject to technical alterations.



This combination enables the customer to clamp different components within a fixture concept and to further expand them for new parts.



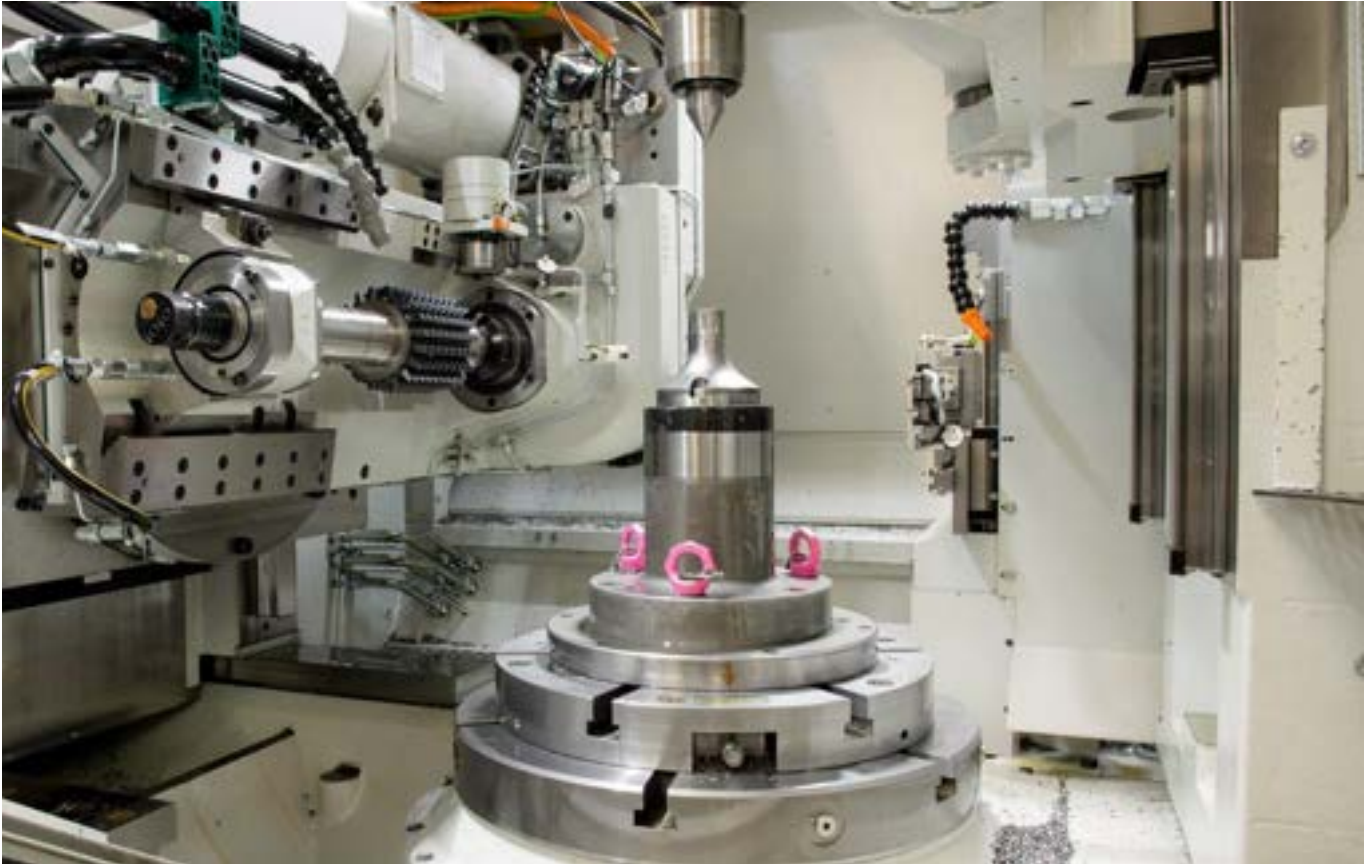

Zero-point clamping technology in use on an interlocking milling machine.
Reliable fit in the case of high lateral forces and long lever ratios.

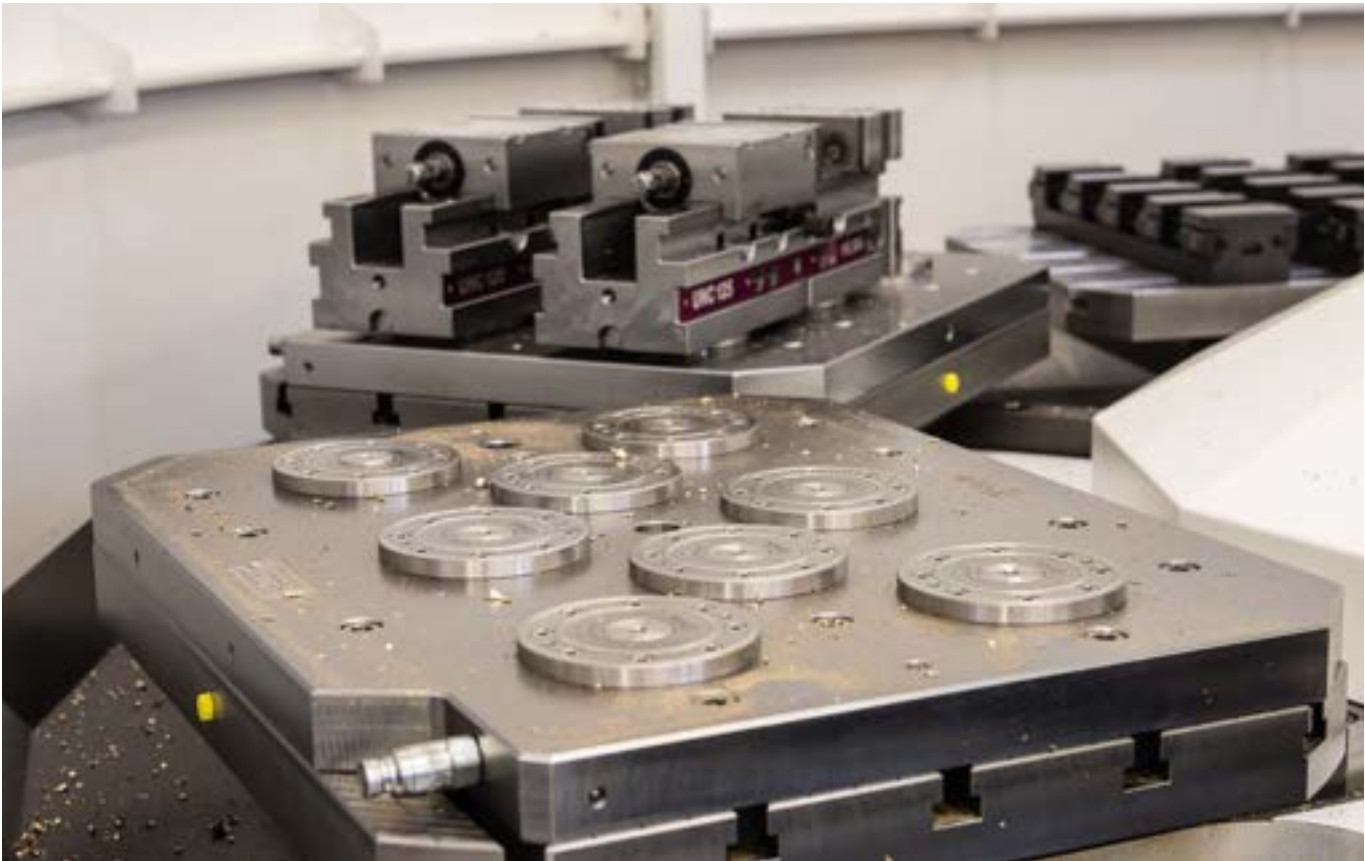

More flexibility in the pallet storage unit thanks to the zero-point-system.
The capacity of the pallet storage unit is expanded by simple and fast conversion of the different pallets.

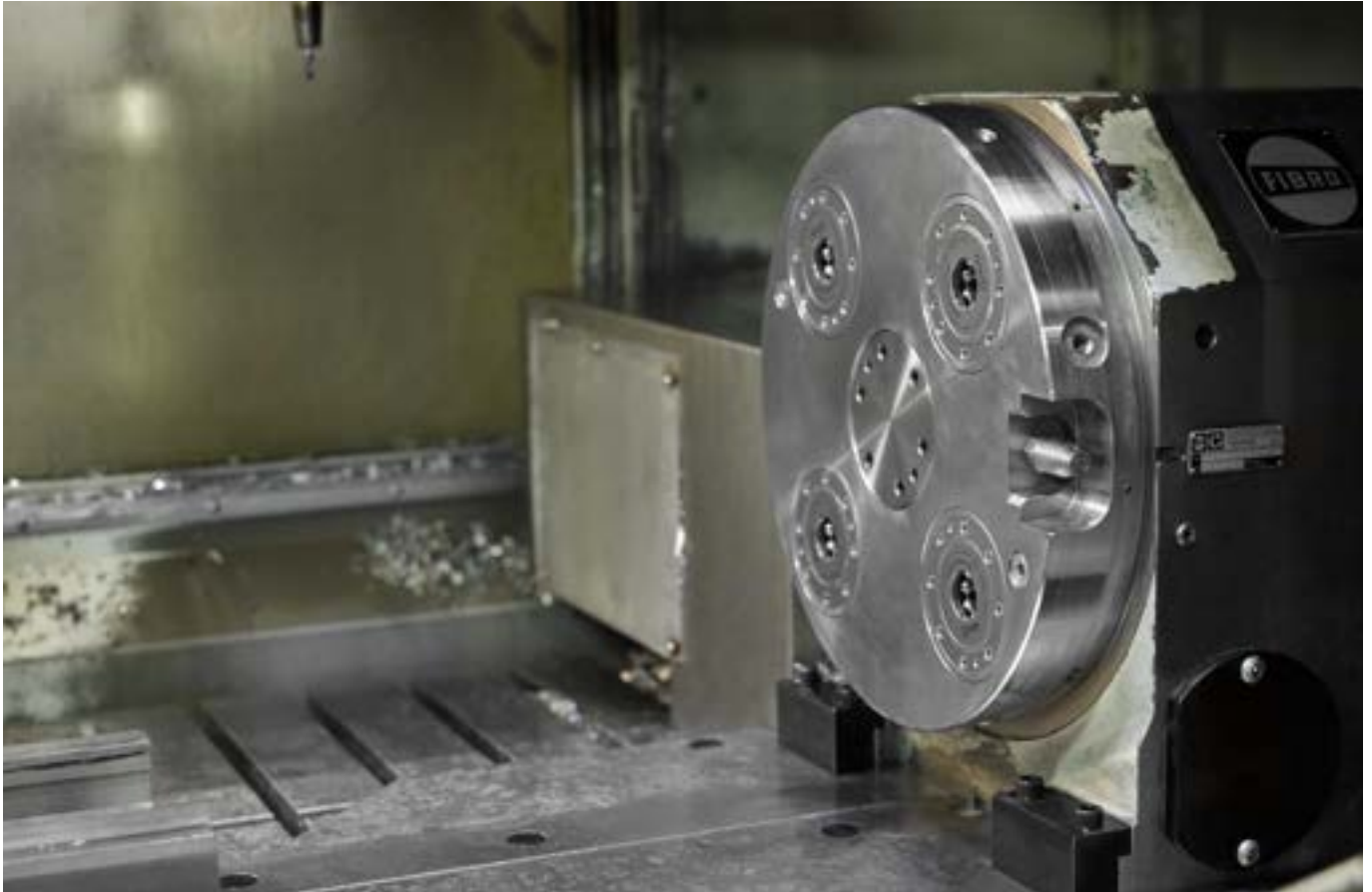

AMF zero point clamping system in use on a grinding/milling machine.
It is well worth using, particularly in the case of existing machines with long and frequent set-up procedures.





Zero-point clamping technology used in large engine production.
Efficiency by setting up mechanical clamping fixtures in parallel during production time.



The two-section clamping pin system with a large intake catchment and the ball retainer-free module design makes it possible to change the clamping device ergonomically without tilting.



Whether at a standard module distance of 200 x 200 mm or in any other pitch spacings and arrangements of the clamping modules, the AMF zero-point system can be adapted to any practical requirement.



Thanks to the low installation height of our clamping modules, the assembly of the clamping device can be adapted flexibly to the respective machining height and workpiece



Simple changing of a 3-jaw chuck by means of the AMF zero-point system.



Direct clamping of the workpiece on a horizontal machining centre.
Two of the four zero-point clamping consoles can be adjusted in height. This enables workpiece tolerances to be compensated.



The AMF zero-point system offers a secure fit during drilling operations under unfavourable lever ratios. Thus, even complex workpieces with high cutting parameters can be machined reliably.



Clamping profile with three pneumatic 4-point clamping stations. Thanks to the high pull-in forces of the zero-point system, changing the clamping device becomes simple and user friendly even in the case of horizontal applications.



In injection moulding, the tools are successfully changed in a way that optimises set-up time through the use of the AMF zero-point system.
With friendly recommendation of Robert Bosch GmbH, Waiblingen

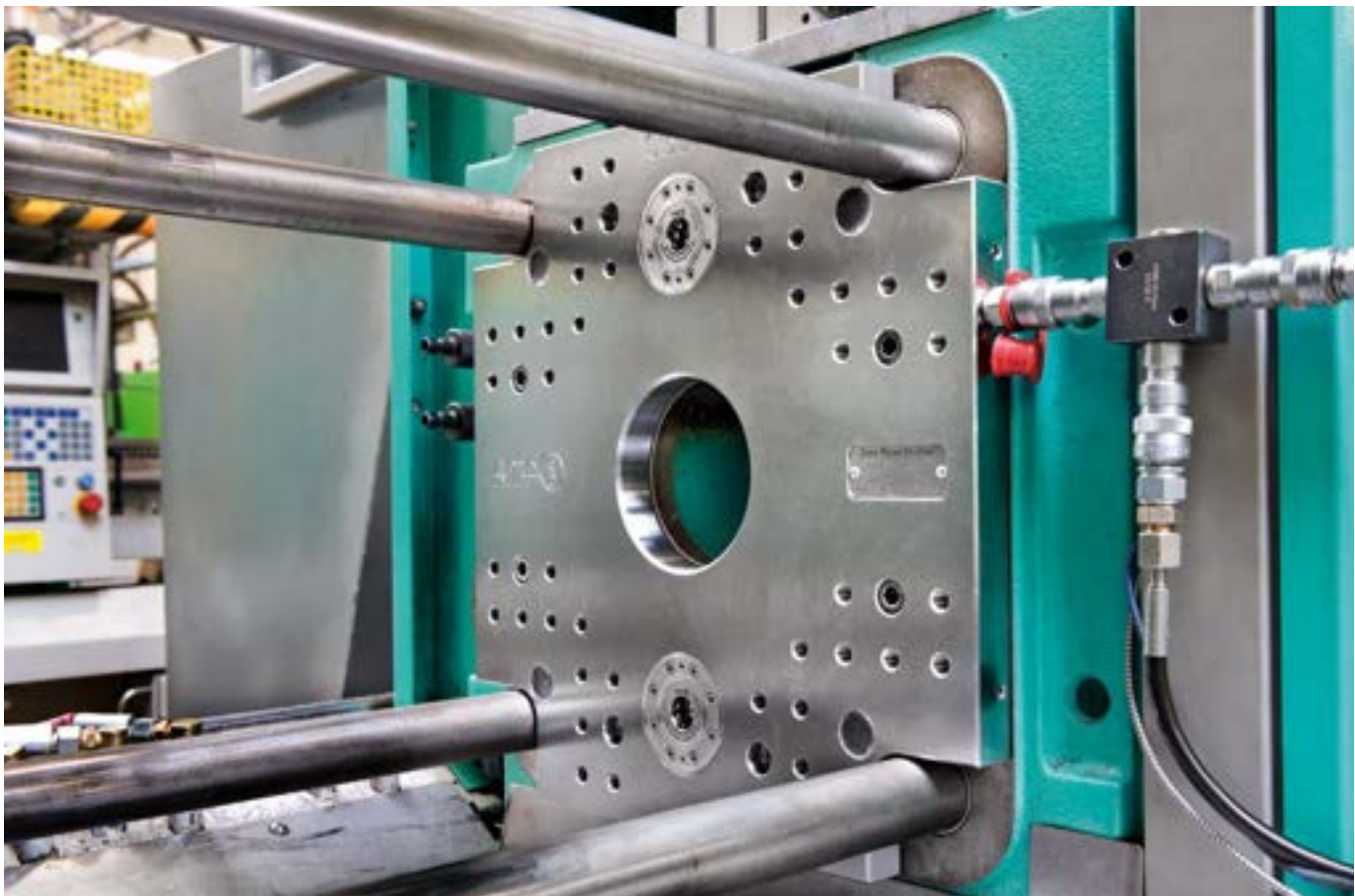

Subject to technical alterations.



The cylindrical design of the pull-studs and the adapter in the clamping module guarantee a balance of height and length tolerances even at long distances.





5-axis-machining of machine building components. 4-point clamping station with individual outer contour for maximum accessibility.



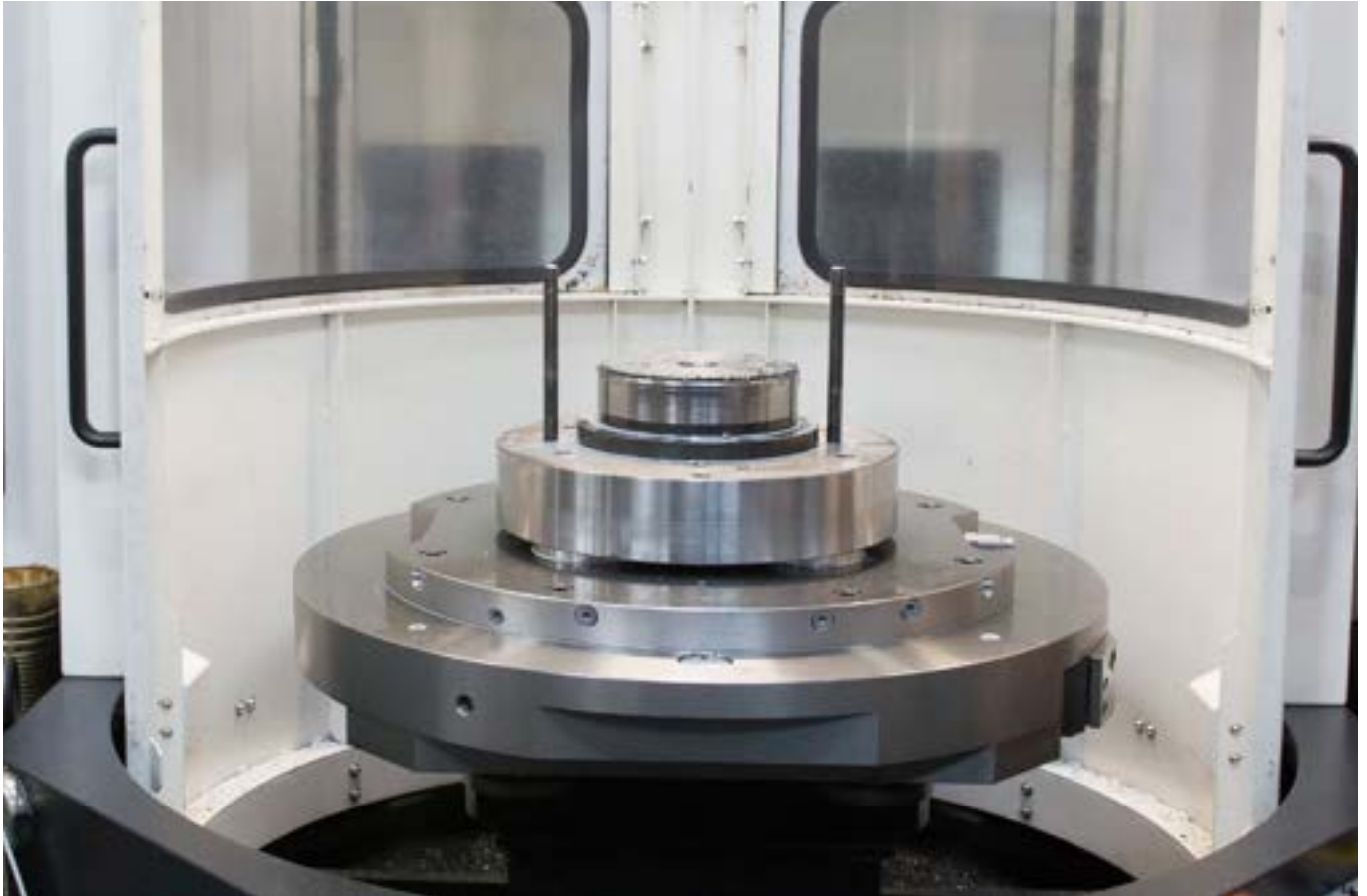

AMF zero-point clamping system in use on a milling-grinding centre with pallet.
The zero-point system is the standard interface here on all machine pallets.





The 4-point clamping station replaces the machine table. This guarantees maximum utilisation of the machine's stroke.



The interior of the clamping module is completely sealed. This means that the system is optimally protected against liquids and dirt.



Use in the food industry

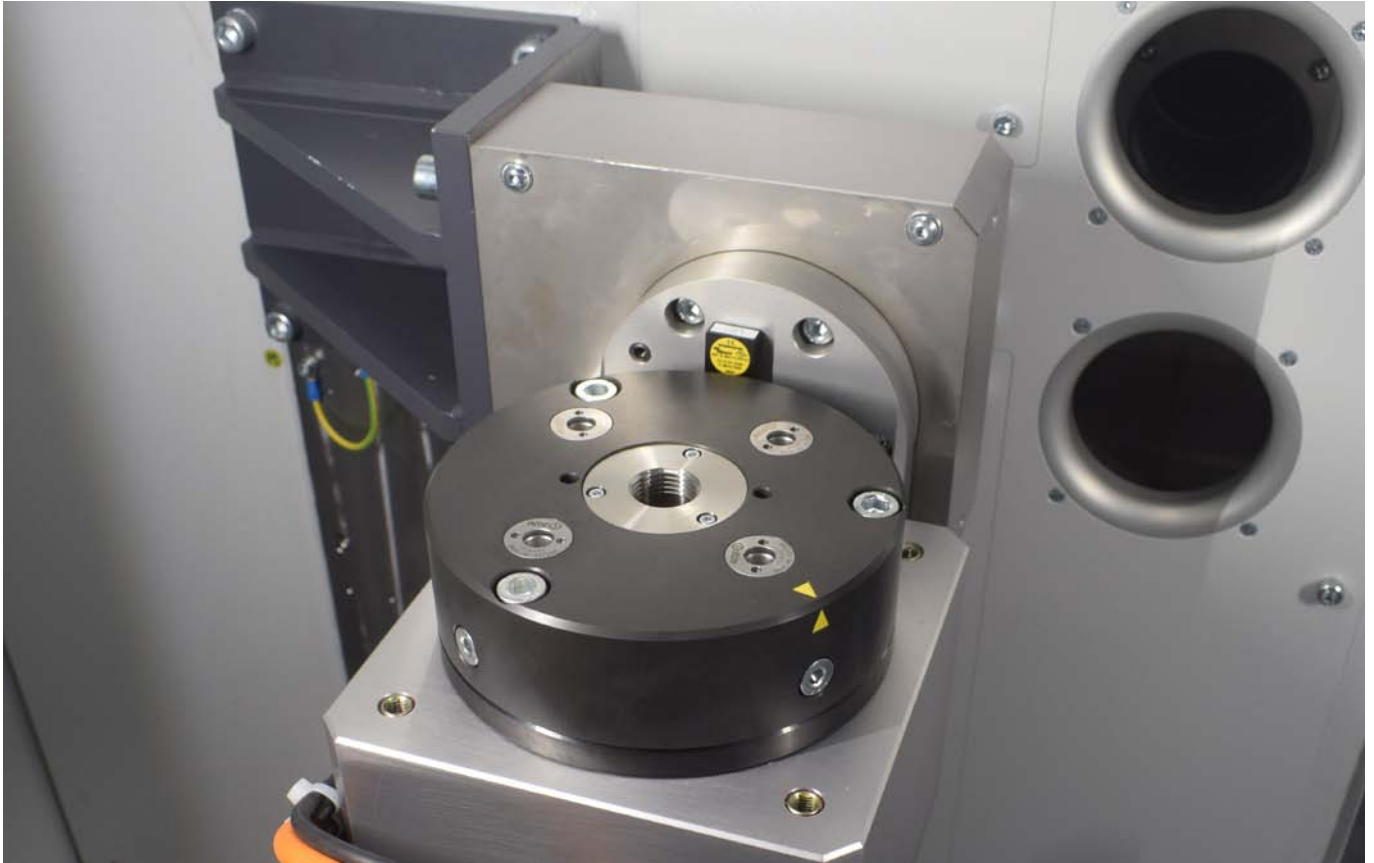

Our SP150 clamping modules in operation on a laser welding system for round parts and small parts. The compact layout facilitates versatile operation of various welding applications. Including clamping arrangements with a central aperture. This increases flexibility and increases process reliability.

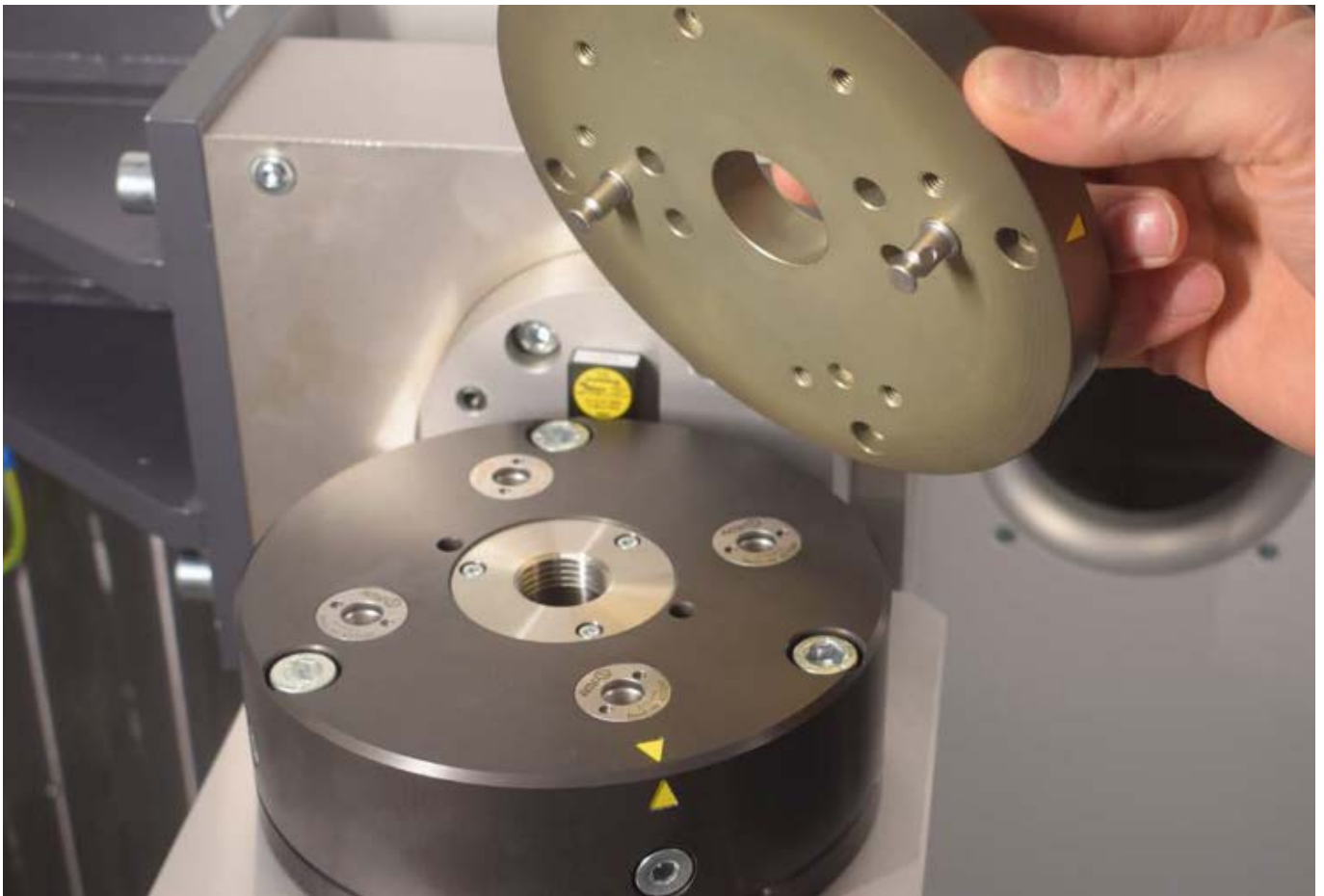



Automation solution with AMF zero-point system as standard interface for robotic loading.





Numerous sensor options and reliable fit with high handling weights guarantee smooth integration into automated robotic loading as well as subsequent machining.



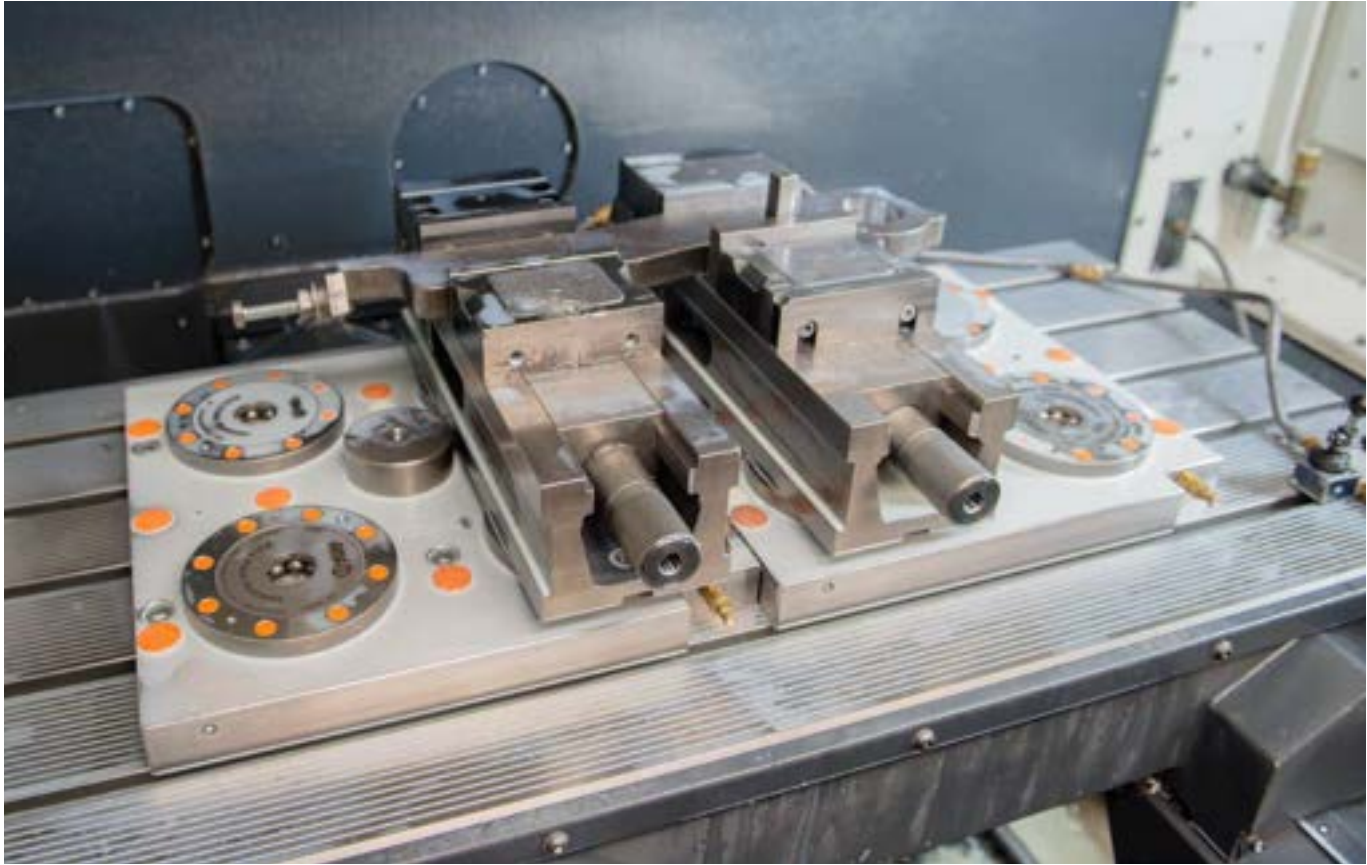

Two pneumatic standard clamping stations retrofitted on a 3-axis milling machine.
The easy entry point into zero-point clamping technology, available from stock.

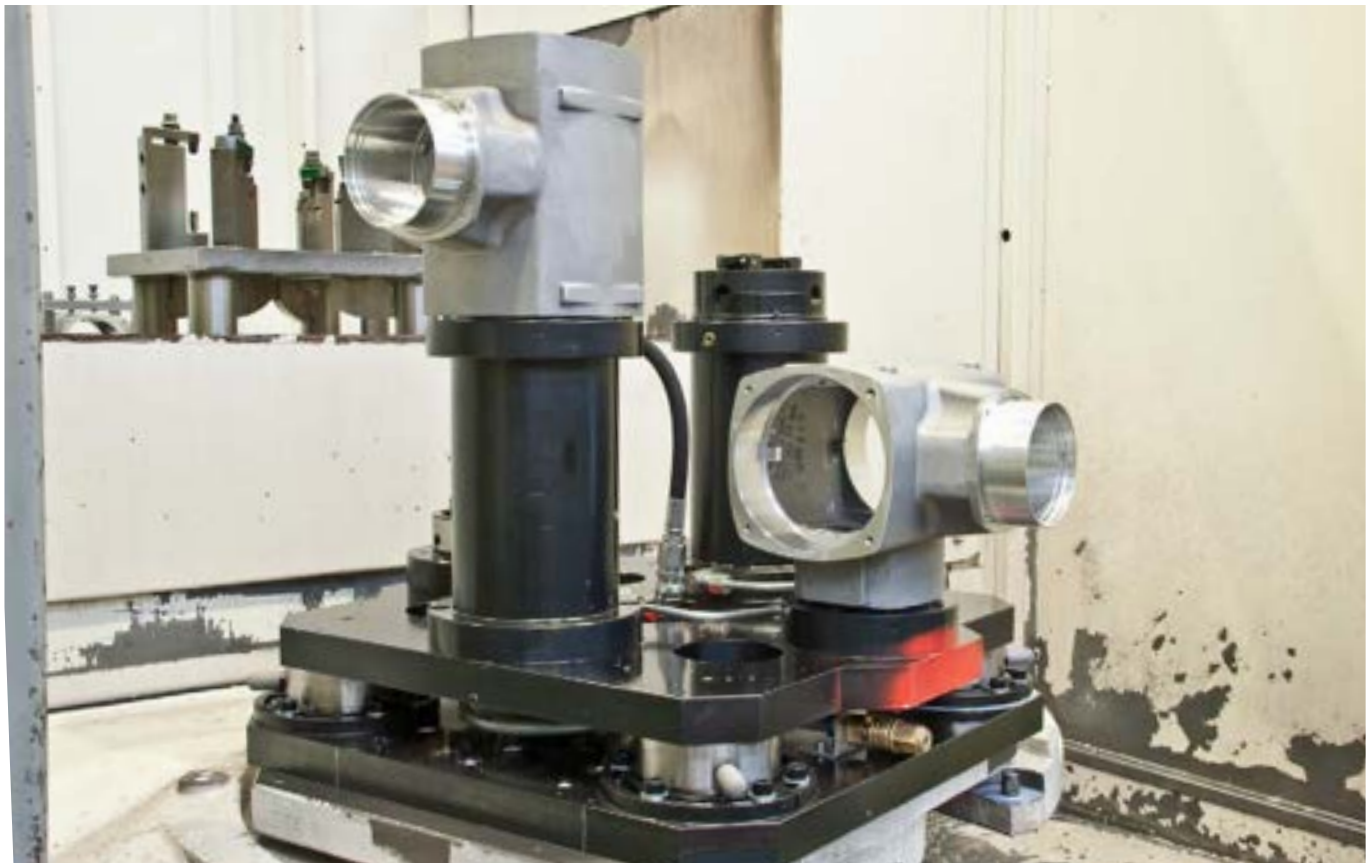

Surface-mounted clamping modules in combination with AMF hydraulic clamping systems on a machining centre.



AMF-Clean-Stick in use: automated cleaning of clamping fixture and machine table.



Top and bottom-sided integrated clamping module in a rotary indexing table. The set-up times have been reduced from several hours to a few minutes and the flexibility of the entire machine has been increased to a maximum.

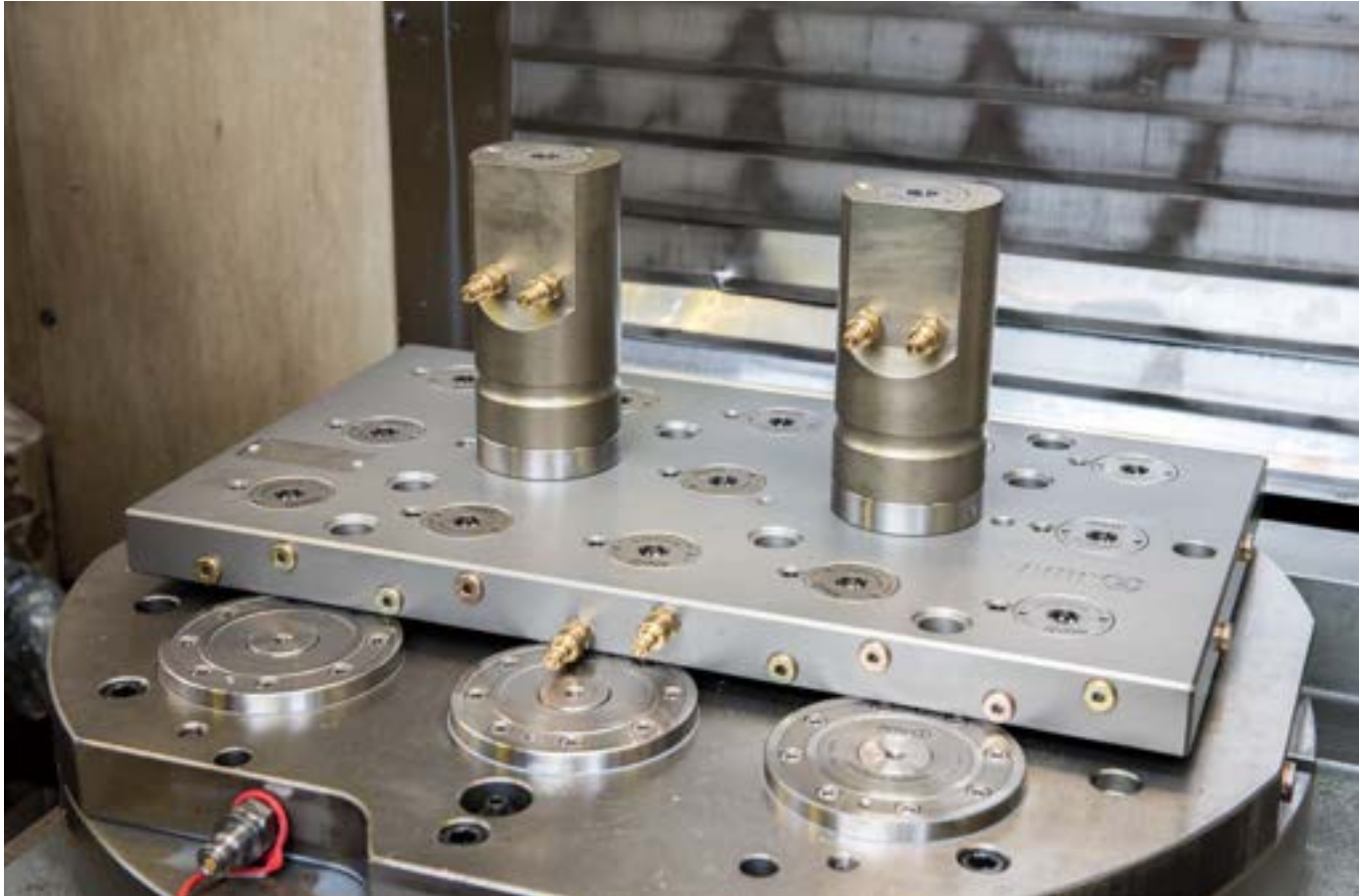

5-side machining by means of clamping brackets for direct clamping of the component.

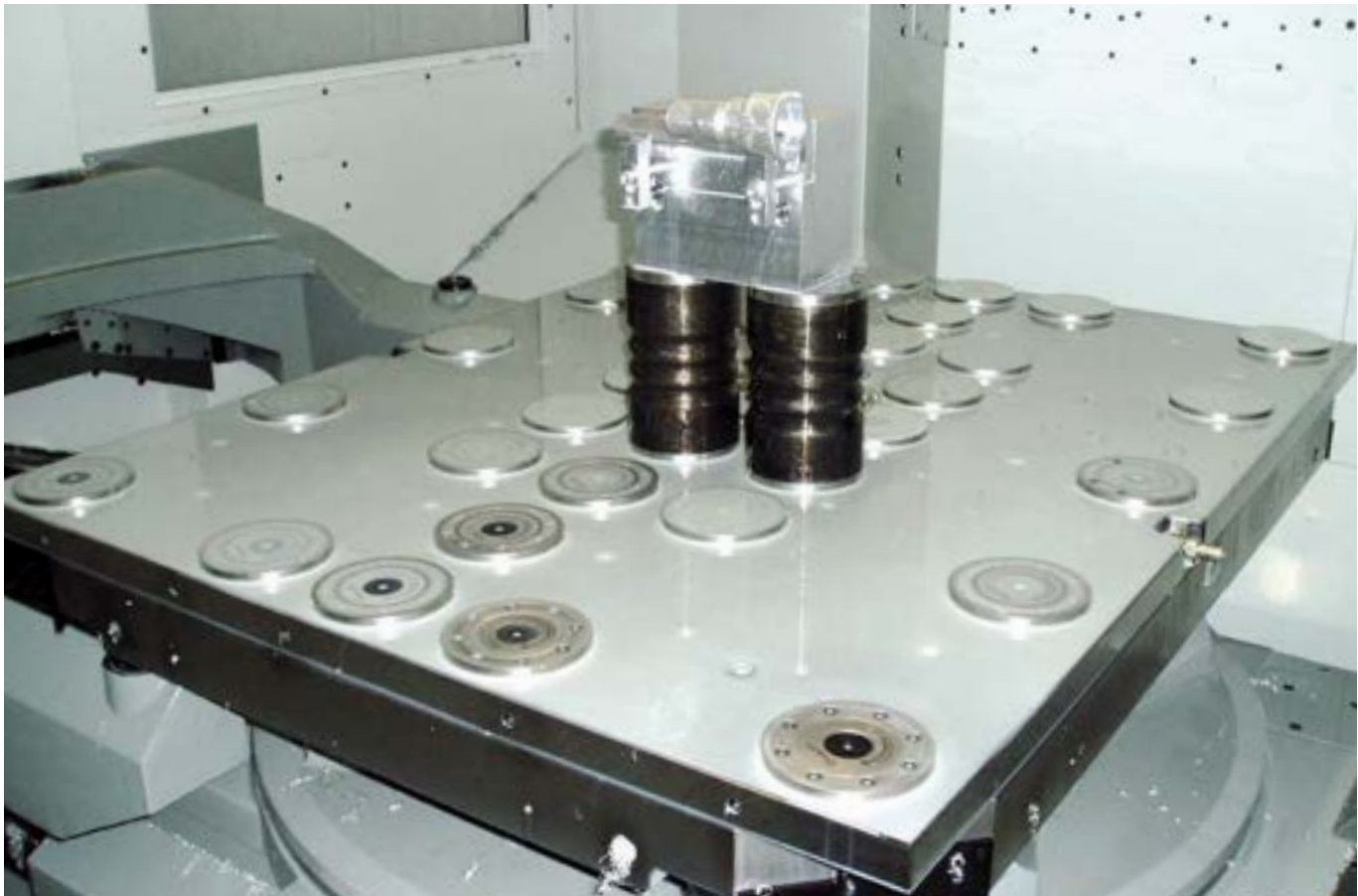



4-point clamping station with integrated bearings and direct locking control system for use on milling-grinding machines up to a maximum speed of 2200 rpm.



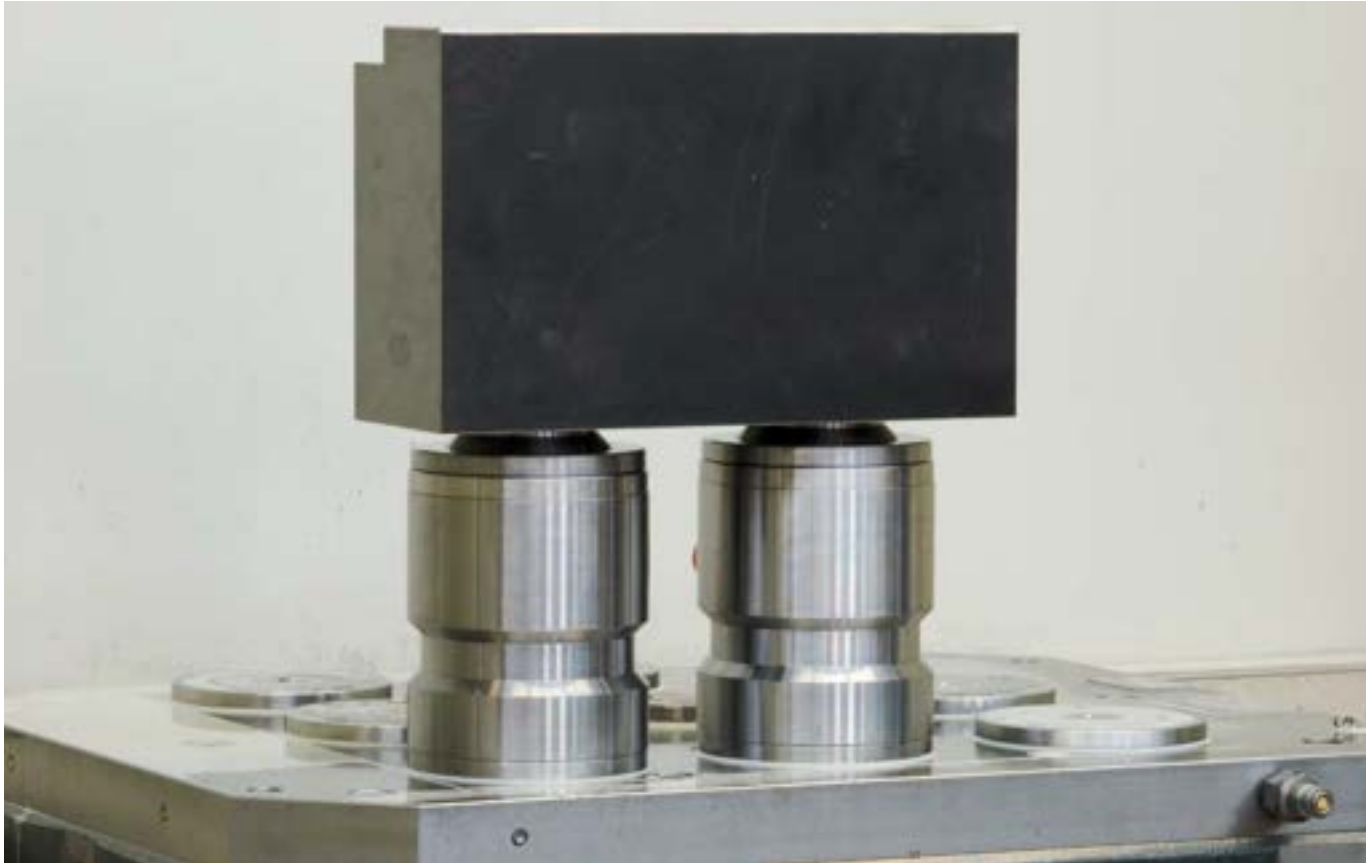

AMF protective shields as useful accessory for direct clamping of the component.
It ensures complete machining of the workpiece axially to the clamping bracket.



Hydraulic vice for machining multiple or various workpieces in one clamping process
clamped on the zero-point system.



Zero point clamping bracket used in heavy duty machining.



Surface-mounted clamping modules with clamping flanges for easy and flexible positioning of the T-slot tables.

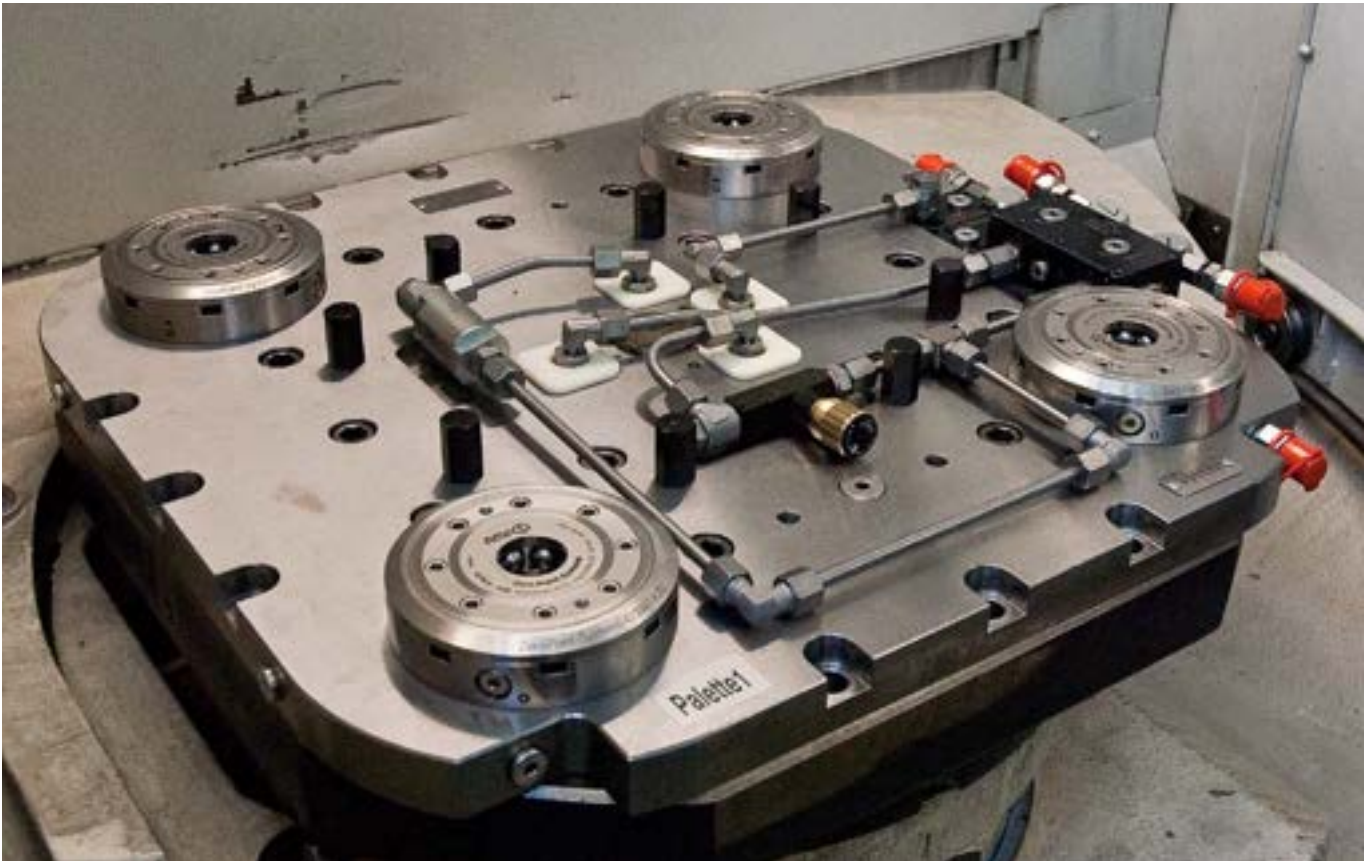

Combined application between zero-point clamping technology and hydraulic media transfer.
This enables the supply of media for existing hydraulic clamping fixtures.



Integration clamping module as flange version for installation on clamping profiles.



Automation solution with lock and support control as well as pull-stud sensor used in a fully automated production process with robotic loading.



The cylindrical mating receptacle makes recessed installation of the clamping modules easily possible without any loss of precision.



Zero-point clamping technology as standard interface on a coordinate measuring machine. Automation even in post-processing.



The high precision of the AMF zero-point system permits use in grinding technology.



Combined application of vacuum and zero-point clamping technology.
The vacuum clamping plate is equipped with pull-stud mountings at the factory.



The mechanical collet is clamped directly using zero-point clamping technology.
Ideal for clamping thin-walled or sensitive workpieces with complex outer contours.



4-point clamping station K02 with interchangeable pallet.





CONVENIENT ORDERING – IN OUR ONLINE SHOP

- + Over 6000 products can be ordered online
- + Order tracking online
- + Easy download of CAD data
- + Online inquiry of availability
- + Management of different shopping carts



**LOG IN NOW AT
SHOP.AMF.DE**

YOU ALREADY HAVE A CLAMPING SYSTEM?!

YOU CAN STILL TAKE ADVANTAGE OF OUR BENEFITS ...

With our „Gonzales“ and „Unitool“ clamping modules, we offer you flexibility in retrofitting and expanding your existing zero-point clamping technology. As a result, a complete replacement of the system you currently use is no longer absolutely necessary. You keep your investment as low as possible and still take advantage of the benefits of the AMF Zero-Point System.



„GONZALES“ CLAMPING MODULE (FIG. LEFT)

Your existing Speedy 1000/2000 or DockLock 1000 modules can be exchanged for our corresponding „Gonzales“ modules if you meet the following requirements:

- > Unlike Speedy 1000/2000 and DockLock 1000, „Gonzales“ requires a hydraulic unclamping pressure of min. 50 bar / max. 60 bar.
- > With countersunk installation, replacement is only possible if there is enough space for the larger covers of the „Gonzales“ modules (cover dia. 112 mm or 140 mm).
- > Modules with media ducts cannot be exchanged
- > Use „Gonzales“ modules exclusively with „Gonzales“ modules in one clamping.

With the „Gonzales“ modules, the corresponding pull-studs of the systems Speedy 1000/2000 and DockLock 1000 can be clamped. „Gonzales“ pull-studs can be clamped with the corresponding Speedy 1000/2000 and DockLock 1000 modules.

„UNITOOL“ CLAMPING MODULE (FIG. RIGHT)

Our „Unitool“ clamping module fits the pull-stud of the Unilock system (dia. 40 mm). The Unitool pull-stud also fits the Unilock system module (NSE-138).

STAINLESS STEEL



High-alloy, hardened tool steel - and so no corrosion.

SAFETY SYSTEM



Process reliability - Clamping module always opens. A piston blockade is thus impossible (only Gonzales modules).

FORM FIT



The balls are optimally encapsulated on 3 sides. As a result, the pull-stud always remains firmly clamped in the module.

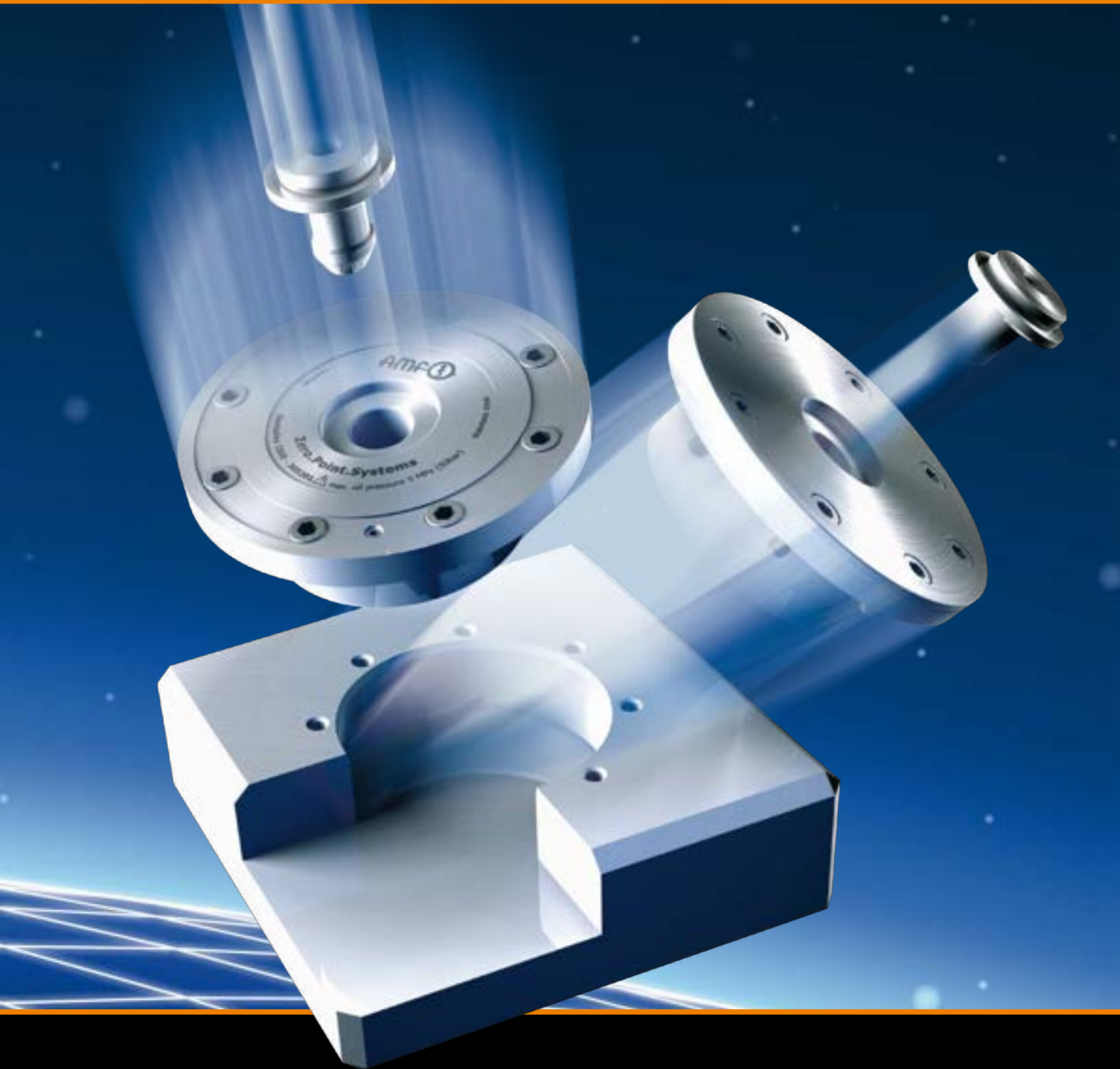

NO BALL CAGE



The balls lie freely in the ball canal. This freedom of movement enables the balls to continuously re-position themselves.

SWING-FREE



Swing-free run-in and run-out through the optimal contour of the pull-stud (only Gonzales modules).

THREE-POINT PRINCIPLE

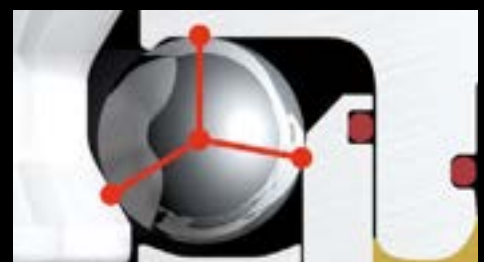

Power transmission by means of the three-point principle! This optimised force distribution prevents shearing load on the balls.

No. 6370EGRH

Installation clamping module “Gonzales”

Hydraulic opening.
Opening operating pressure: min. 50 bar - max. 60 bar.
Cover and piston hardened.
Repeatability < 0.005 mm.

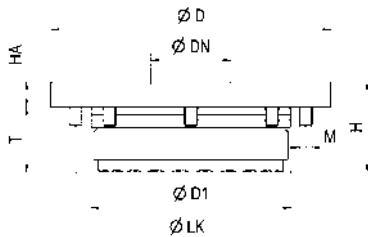

CAD



Order no.	Size	Pull-in/locking force up to	Holding force*	Speedy	DockLock	Weight
		[kN]	[kN]			
305201	1000	15	25	●	-	2,3
306043	1000	15	25	-	●	2,3
305219	2000	25	55	●	-	3,5

Application:

Zero-point clamping system for set-up-time-optimised clamping during cutting and non-cutting machining.

Note:

Use „Gonzales“ modules exclusively with „Gonzales“ modules in one clamping. When changing systems, observe the following: Unlike Speedy 1000/2000 and DockLock 1000, „Gonzales“ modules require an unclamping pressure of min. 50 bar / max. 60 bar. With recessed installation, observe the cover diameter D 112 mm / 140 mm. The installation clamping module is opened hydraulically (1) and mechanically locked through spring force. Subsequent uncoupling of the pressure lines is possible at all times (module is tensioned pressure-free).

The clamping module has one connection: 1x hydr. opening (1).

* Please observe the installation instructions.

On request:

- Installation diagrams

Dimensions:

Order no.	Size	dia. D	dia. DN	dia. D1	H	HA	dia. LK	M	T
305201	1000	112	32	80	36	10	92	8 x M5	26
306043	1000	112	32	80	36	10	91	10 x M5	26
305219	2000	140	47	110	36	10	122	8 x M5	26

No. 6370AGRH

Surface-mounted clamping module “Gonzales”

Hydraulic opening.
Opening operating pressure: min. 50 bar - max. 60 bar.
Cover and piston hardened.
Repeatability < 0.005 mm.

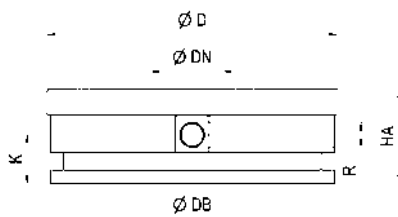

CAD



Order no.	Size	Pull-in/locking force up to	Holding force*	Weight
		[kN]	[kN]	
303362	1000	15	25	2,3
303388	2000	25	55	3,5

Application:

Zero-point clamping system in combination with hook clamping flange 63707BG for set-up-time-optimised clamping during cutting and non-cutting machining.

Note:

Use „Gonzales“ modules exclusively with „Gonzales“ modules in one clamping. When changing systems, observe the following: Unlike Speedy 1000/2000 and DockLock 1000, „Gonzales“ modules require an unclamping pressure of min. 50 bar / max. 60 bar. The surface-mounted clamping module is opened hydraulically (1) and mechanically locked through spring force. Subsequent uncoupling of the pressure lines is possible at all times (module is tensioned pressure-free).

The clamping module has one connection: 1x hydr. opening (1).

* Please observe the installation instructions.

On request:

- Installation diagrams

Dimensions:

Order no.	Size	dia. D	dia. DB	dia. DN	HA	K	R
303362	1000	112	110	32	36	18,5	G1/8
303388	2000	140	139	47	40	18,5	G1/8

Subject to technical alterations.

No. 6370EURL

Installation clamping module „Unitool“

Pneumatic opening.
 Opening operating pressure: min. 8 bar - max. 12 bar.
 Retensioning operating pressure (turbo): min. 5 bar - max. 6 bar.
 Cover and piston hardened.
 Repeatability < 0.005 mm.

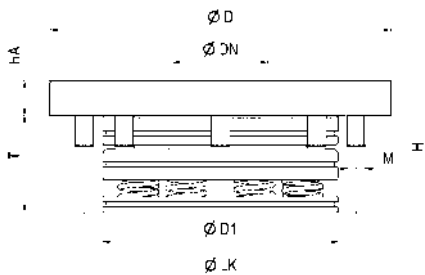

Order no.	Pull-in/locking force up to	Holding force*	Weight
	[kN]	[kN]	[Kg]
303560	30	55	3,2

Application:

Zero-point clamping system for set-up-time-optimised clamping during cutting and non-cutting machining.

Note:

The installation clamping module has high holding, pull-in and locking forces. This is opened pneumatically (1) and mechanically locked through spring force. To achieve the specified pull-in and locking forces, it must be briefly retensioned pneumatically (turbo) (2). Subsequent uncoupling of the pressure lines is possible at all times (module is tensioned pressure-free). Use of the pneumatic pressure booster 6370ZVL-005 is recommended.

The clamping module has two connections:

1x pneum. opening (1) / 1x pneum. retensioning (turbo) (2).

Use „Unitool“ modules exclusively with „Unitool“ modules in one clamping.

* Please observe the installation instructions.

On request:

- Installation diagrams

Dimensions:

Order no.	dia. D	dia. DN	dia. D1	H	HA	dia. LK	M	T
303560	148	40	102	57	15	118	M8	42

No. 6370AURL

Installation clamping module „Unitool“

Pneumatic opening.
 Opening operating pressure: min. 8 bar - max. 12 bar.
 Retensioning operating pressure (turbo): min. 5 bar - max. 6 bar.
 Cover and piston hardened.
 Repeatability < 0.005 mm.

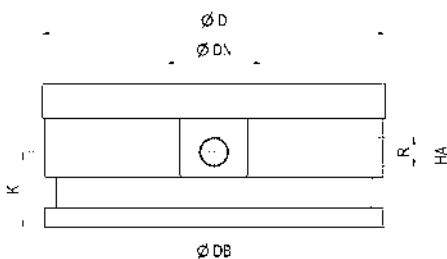

Order no.	Pull-in/locking force up to	Holding force*	Weight
	[kN]	[kN]	[Kg]
303586	30	55	6,5

Application:

Zero-point clamping system in combination with hook clamping flange 6370ZB for set-up-time-optimised clamping during cutting and non-cutting machining.

Note:

The surface-mounted clamping module has high holding, pull-in and locking forces. This is opened pneumatically (1) and mechanically locked through spring force. To achieve the specified pull-in and locking forces, it must be briefly retensioned pneumatically (turbo) (2). Subsequent uncoupling of the pressure lines is possible at all times (module is tensioned pressure-free). Use of the pneumatic pressure booster 6370ZVL is recommended.

The clamping module has two connections:

1x pneum. opening (1) / 1x pneum. retensioning (turbo) (2).

Use „Unitool“ modules exclusively with „Unitool“ modules in one clamping.

* Please observe the installation instructions.

On request:

- Installation diagrams

Dimensions:

Order no.	dia. D	dia. DB	dia. DN	HA	K	R
303586	148	146	40	62	32,5	G1/4

Subject to technical alterations.

No. 6370ZNG-10

Pull-stud „Gonzales 1000“

Hardened.
Pull-stud can also be used in the modules Speedy 1000 and DockLock 1000.



Order no.	Size	dia. DN	dia. D1	H	M	T	Weight [g]
303404	1000	32	25	34,0	M8	4,8	70
303420	1000	32	25	34,0	M8	4,8	70
303446	1000	32	25	34,0	M8	4,8	70
303461	1000	32	-	29,2	M8	12,0	55

Design:

Order no. 303404: zero point pull-stud
order no. 303420: timing pull-stud
order no. 303446: undersize pull-stud
order no. 303461: protection pull-stud

Note:

Tightening torque of the clamping nipple max. 20 Nm. Min. screw grade 8.8.

Dimensions for machining pull-stud mountings:

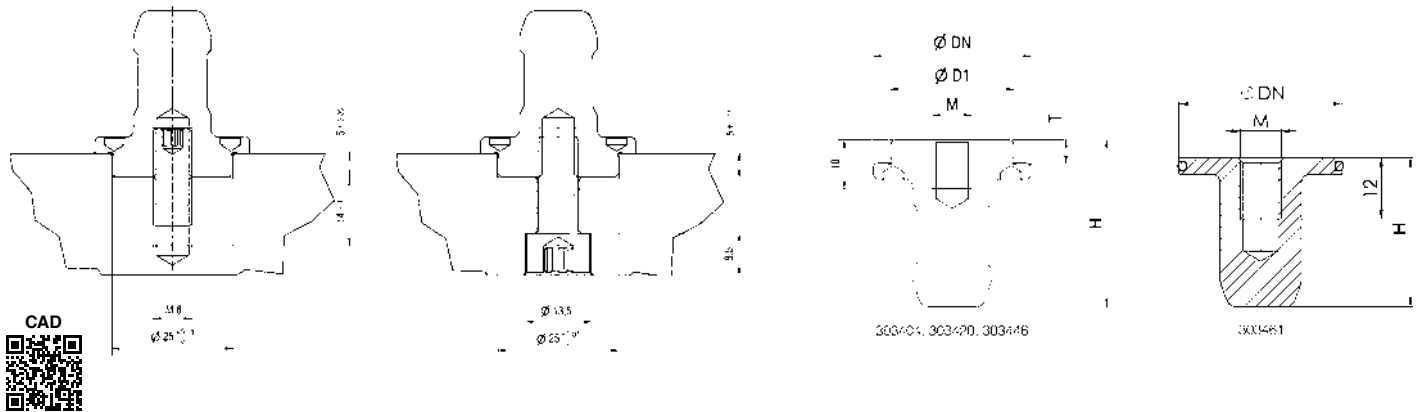

No. 6370ZNGH-10

Pull-stud „Gonzales 1000“

With high collar, hardened.
Pull-stud can also be used in the modules Speedy 1000 and DockLock 1000.



Order no.	Size	dia. DN	dia. D1	H	M	T	Weight [g]
305128	1000	32	25	49	M8	19,8	125
305144	1000	32	25	49	M8	19,8	125
305169	1000	32	25	49	M8	19,8	125
303461	1000	32	-	29,2	M8	12,0	55

Design:

Order no. 305128: zero point pull-stud
order no. 305144: timing pull-stud
order no. 305169: undersize pull-stud
order no. 303461: protection pull-stud

Note:

Tightening torque of the pull-stud max. 20 Nm. Screw grade min. 8.8.

Dimensions for machining pull-stud mountings:

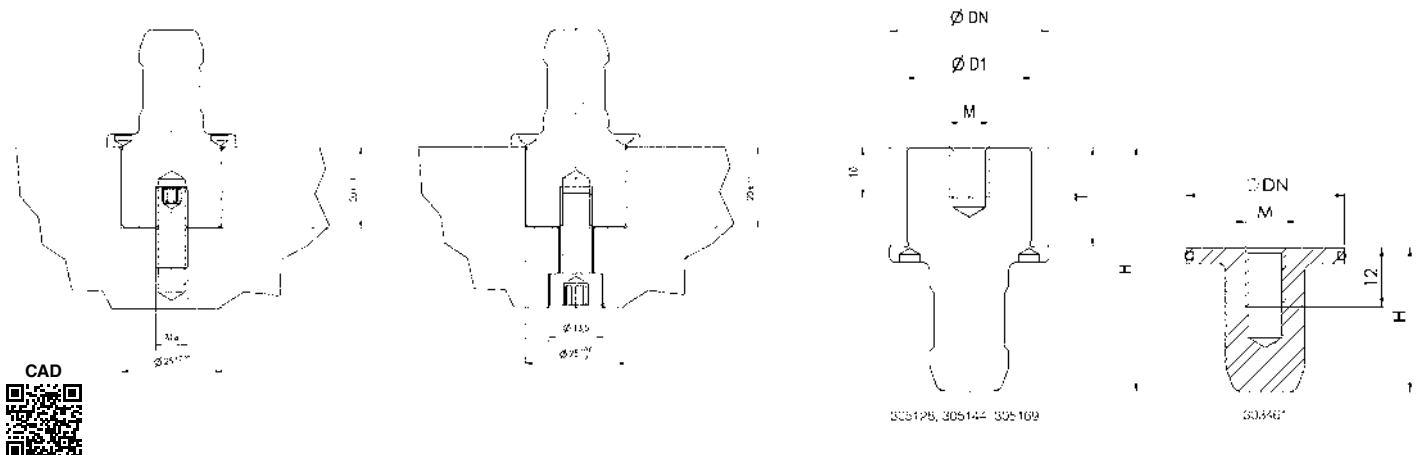

Subject to technical alterations.

No. 6370ZNG-20

Pull-stud „Gonzales 2000“

Hardened.

Pull-stud can also be used in Speedy 2000.



Order no.	Size	dia. DN	dia. D1	dia. D2	H	M	T	Weight [g]
303412	2000	47	25	10,8	34,0	M12	4,8	170
303438	2000	47	25	10,8	34,0	M12	4,8	170
303453	2000	47	25	10,8	34,0	M12	4,8	170
303479	2000	47	-	-	29,2	M 8	12,0	180

Design:

Order no. 303412: zero point pull-stud

order no. 303438: timing pull-stud

order no. 303453: undersize pull-stud

order no. 303479: protection pull-stud

Note:

Tightening torque of the pull-stud max. 20 Nm. Screw grade min. 8.8.

Dimensions for machining pull-stud mountings:

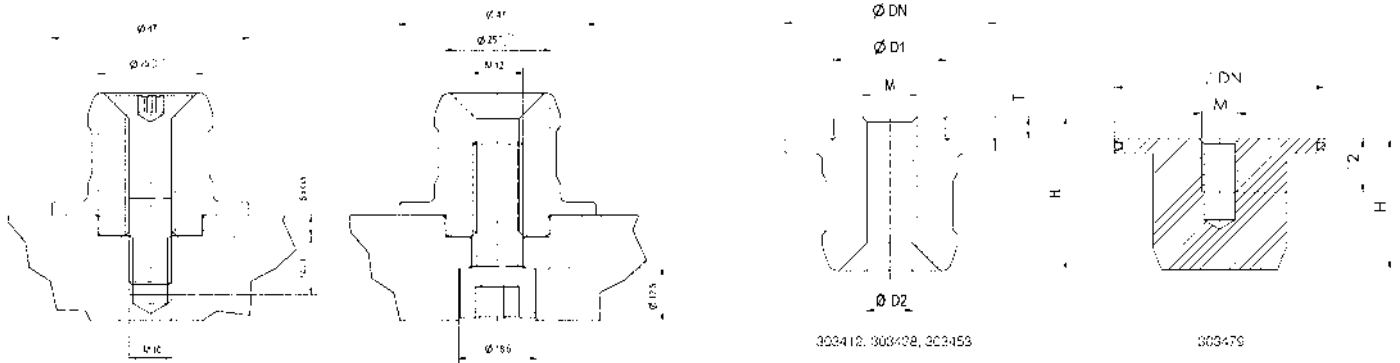

No. 6370ZNSG

Pull-stud key „Gonzales“

For pull-stud no. 6370ZNG/ZNGH „Gonzales 1000“.

Order no.	SW [mm]	Weight [g]
306001	22	80

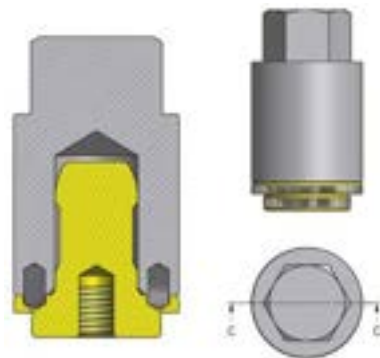

No. 6370ZNU

Pull-stud „Unitool“

Hardened.
Pull-stud can also be used in Unilock system (Ø 40 mm).



Order no.	dia. DN	dia. D1	dia. D2	H	M	T	Weight [g]
304352	40	25	10	40,0	M12	4,8	230
304592	40	25	10	40,0	M12	4,8	230
304618	40	25	10	40,0	M12	4,8	230
304634	40	-	-	34,7	M 8	12,0	220

Design:

Order no. 304352: zero point pull-stud
 order no. 304592: timing pull-stud
 order no. 304618: undersize pull-stud
 order no. 304634: protection pull-stud

Dimensions for machining pull-stud mountings:

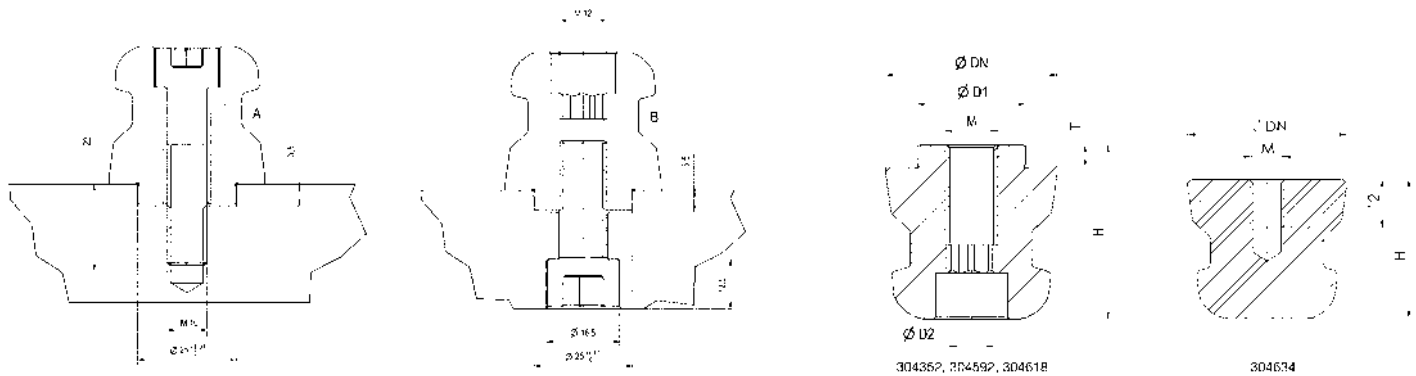



WE DEVELOP THE RIGHT SOLUTION – POTENTIAL SAVINGS BY REDUCING SET-UP TIMES

As a system provider with its own production facility, not only do we have the right product for every need. With many years of experience from all fields of clamping technology we develop the perfect solution for different industries, special projects and for very individual requirements.

With full concentration on a single project, an entire team supports you at AMF, which unites all facets for a successful result.

In close cooperation and with short communication channels, our experienced experts from sales, proposal preparation and purchasing work together with our engineers and designers from the development and production departments.

Thus, we can always ensure that all criteria for a cost-effective production process are met – our specialists look forward to exciting new challenges. **Just talk to us!**



We will be happy to advise you
during your current project.
+49 711 5766-2531



... BY ITEM NO.

Article no.	Page	Article no.	Page	Article no.	Page	Article no.	Page	Article no.	Page
No. 6101L	52	No. 6204S4HA-002	100	No. 6210IZ	81	No. 6370EURL	203	No. 6370ZNSSN	135
No. 6103HA-20-05	46	No. 6204S4HA-003	100	No. 6210L	72	No. 6370HARH	28	No. 6370ZNS-001	131
No. 6103LA-5	40	No. 6204S6HA-001	99	No. 6210L-10-05	66	No. 6370KARH	30	No. 6370ZNS-002	134
No. 6104L	51	No. 6204S6HA-002	101	No. 6210S	74, 75	No. 6370P2	120	No. 6370ZNU	206
No. 6107HA-20-07	47	No. 6204S6HA-003	101	No. 6210-XX	90	No. 6370P4	120	No. 6370ZN-10	127, 128
No. 6108LA-XX-08	41	No. 6204S6HA-004	102	No. 6210Z	80	No. 6370P6	121	No. 6370ZN-20	129, 130
No. 6108LA-XX-09	42	No. 6204S6HA-008	106	No. 6210ZN	59	No. 6370S2-001	114	No. 6370ZN-20-029	137
No. 6108LA-XX-10	43	No. 6204S8HA-001	99	No. 6210-15-01	90	No. 6370S2-002	114	No. 6370ZN-40	131
No. 6109SP-150	50	No. 6204WU12HA-001	106	No. 6211P	112	No. 6370S4-001	115	No. 6370ZN-5	126
No. 6109ZB-150	50	No. 6204ZS-01	140	No. 6211S	112	No. 6370S6-001	116	No. 6370ZR	148
No. 6111LA-10-01	44	No. 6204ZS-02	140	No. 6212M	60	No. 6370ZA	136	No. 6370ZRA	148
No. 6111LA-10-05	45	No. 6206ILA	25	No. 6212MA-20-10	89	No. 6370ZAR	139	No. 6370ZR-02	153
No. 6151HA	27	No. 6206LA	24	No. 6214RM-250	54	No. 6370ZAS	139	No. 6370ZSA-01	49
No. 6151L	27	No. 6206S2L	108	No. 6214RM-250-04	136	No. 6370ZB	34	No. 6370ZSA-02	48
No. 6203PS4-150	95	No. 6206S4L	109	No. 6214RM-251	55	No. 6370ZD	146	No. 6370ZSA-03	49
No. 6203SP	17	No. 6206S6L	110	No. 6214ZMW-250	138	No. 6370ZD-004	146	No. 6370ZSB	70
No. 6203S4L-150	95	No. 6206ZS	140	No. 6214ZN-250-01	123	No. 6370ZF	155	No. 6370ZSK	150, 153
No. 6203ZMW	138	No. 6208IM	57	No. 6214ZN-250-02	123	No. 6370ZI	143	No. 6370ZSK-08	154
No. 6203ZNA-150	137	No. 6208M	56	No. 6214ZN-250-03	123	No. 6370ZMM	144	No. 6370ZSK-11	151
No. 6203ZN-140	125	No. 6208MD	58	No. 6215RP-250	16	No. 6370ZMMG	144	No. 6370ZSS-04	153
No. 6203ZN-150	125	No. 6209MXY	78	No. 6215RP-251	16	No. 6370ZMN	145	No. 6370ZSV-01	154
No. 6204HA	19	No. 6209MZ	79	No. 6217EARHA20	22	No. 6370ZMNG	145	No. 6370ZSZ-112	70
No. 6204IHA	19	No. 6209MZA	88	No. 6363-**-005	90	No. 6370ZMSH	28	No. 6370ZS-06-2000	147
No. 6204K1HA-001	103	No. 6210AGS	76	No. 6370AARH	32	No. 6370ZMW-5	138	No. 6370ZS-07	153
No. 6204K1HA-004	103	No. 6210A-20-10	86	No. 6370AARHA	33	No. 6370ZNF-10	133	No. 6370ZS-08	149
No. 6204K2HA-001	105	No. 6210FN	84	No. 6370AARL	32	No. 6370ZNF-20	133	No. 6370ZVL	155
No. 6204K2HA-006	105	No. 6210FNT	83	No. 6370AARLA	33	No. 6370ZNGH-10	204	No. 6370ZVL-004	152
No. 6204K2HA-011	104	No. 6210FN-10-2	85	No. 6370AGRH	202	No. 6370ZNG-10	204	No. 6370ZVL-005	152
No. 6204K2HA-013	104	No. 6210H	68	No. 6370AURL	203	No. 6370ZNG-20	205	No. 6370ZVL-007	154
No. 6204K2HA-015	102	No. 6210H-10-05	64	No. 6370EAIHA	21	No. 6370ZNM	134	No. 6370ZZ	137
No. 6204P-S2	118	No. 6210IA-20-10	87	No. 6370EAILA	21	No. 6370ZNR-10	127, 128	No. 6376Z	141, 142
No. 6204P-S4	118	No. 6210IFR	82	No. 6370EARH	18	No. 6370ZNR-20	129, 130	No. 6916-11	155
No. 6204P-S6	119	No. 6210IH	69	No. 6370EARHA	20	No. 6370ZNSA	136	No. 6984-30	143
No. 6204P-S8	119	No. 6210IH-10-05	65	No. 6370EARL	18	No. 6370ZNSF	133	No. 6985R	149
No. 6204S2HA-001	98	No. 6210IL	73	No. 6370EARLA	20	No. 6370ZNSG	205	No. 6988	151
No. 6204S4HA-001	98	No. 6210IL-10-05	67	No. 6370EGRH	202	No. 6370ZNSN	135		

... BY ORDER NO.

Order no.	Page	Order no.	Page	Order no.	Page	Order no.	Page	Order no.	Page
302836	33	303289	114	304519	127	306043	202	421479	153
302851	33	303297	114	304535	127, 128	306050	126	422345	136
302877	33	303321	115	304592	206	306076	126	422360	136
302893	33	303339	115	304618	206	306092	131	422386	136
303016	20	303362	202	304634	206	306159	32	422402	136
303057	20	303388	202	305128	204	306167	137	422428	136
303065	28	303404	204	305144	204	306175	32	422444	136
303107	28	303412	205	305169	204	306183	137	423962	27
303149	129	303420	204	305193	33	306209	137	423988	27
303156	129	303438	205	305201	202	306217	28	424002	144
303164	129	303446	204	305219	202	306241	137	424085	27
303172	129, 130	303453	205	305375	20	306258	28	424101	27
303180	131	303461	204	305383	155	320986	148	424119	116
303198	131	303479	205	305409	148	321000	148	424143	27
303206	131	303503	30	305417	148	321026	148	424168	27
303214	131	303545	33	305425	148	321042	148	424184	144
303222	131	303560	203	305912	135	321067	148	424200	144
303230	131	303578	131	305938	135	325217	143	424226	144
303248	134	303586	203	305953	18	340034	135	424242	145
303255	134	303610	127	306001	205	340059	135	424267	144
303263	114	303636	127	306019	126	421396	152	424556	28
303271	114	304352	206	306035	126	421453	153	425033	120

... BY ORDER NO.

Order no.	Page	Order no.	Page	Order no.	Page	Order no.	Page	Order no.	Page
425041	120	428169	103	532853	67	552810	139	559933	90
426494	155	428409	46	533034	95	552811	139	560021	151
426569	146	428425	21	533059	95	552812	139	561391	136
426700	120	428441	21	533075	154	552813	139	561989	16
426726	114	428490	19	534412	69	552963	52	561990	22
426734	116	428664	140	534453	73	552964	52	561991	41
426742	115	428680	20	534487	80	552965	52	561992	40
426759	116	428730	24	534495	73	552967	51	561993	89
426767	120	428755	24	534503	80	552968	51	562192	126
426775	121	428771	25	534529	80	553152	24	562193	126
426783	120	428797	25	534537	72	553154	49	562194	126
426791	121	429019	148	534545	80	553182	48	562354	56
426809	120	429266	118	534560	80	553183	49	562355	57
426817	121	429282	118	534586	80	553405	60	562356	58
426825	34	429308	119	534602	80	553995	140	562748	127
426833	34	429324	119	534628	80	554058	79	562750	127
426841	34	429845	20	534644	80	554493	146	562751	127
426866	28	429936	148	534669	80	554926	131	562753	133
426882	135	429969	134	534685	80	554927	131	562755	128
426908	135	429985	134	534701	80	554928	131	562757	128
427088	152	430009	134	534719	65	554929	131	562759	128
427286	17	430025	134	534727	80	554936	128	562761	129
427302	125	430041	153	534743	80	554937	128	562764	129
427328	125	430058	145	534750	86	554938	128	562766	129
427344	125	430066	153	534768	66	554939	130	562767	133
427369	19	430082	147	534776	64	554940	130	562768	130
427484	98	430108	153	534800	68	554941	130	562769	130
427492	100	430124	153	534842	72	554942	131	562771	130
427500	98	430140	153	534883	68	554943	131	562804	137
427518	100	430165	140	534925	72	554944	131	562861	133
427526	99	430181	140	535732	90	558008	149	562862	133
427534	101	430207	141	535757	85	558043	150	563900	18
427542	99	430223	142	550197	90	558044	150	563925	153
427559	101	430264	143	550198	90	558045	148	564839	17
427567	102	430280	127	550249	108	558050	148	564840	125
427575	104	430306	127	550251	109	558051	51	564841	125
427591	102	430322	129	550252	110	558052	88	564842	125
427625	106	430348	129	550254	108	558053	88	564843	138
427641	106	477570	154	550255	109	558903	79	564855	138
427666	105	526517	137	550256	110	558905	78	565059	151
427682	105	531996	81	550257	41	558906	78	565395	138
427708	105	532010	81	550258	41	559089	50	567133	55
427724	105	532036	81	550259	42	559090	54	567134	16
427740	105	532051	81	550260	42	559092	123	567135	123
427765	105	532077	81	550261	43	559093	123	567136	76
427781	105	532093	81	550262	43	559094	60	567137	76
427807	105	532119	81	550279	47	559095	84	567201	154
427823	105	532135	81	550281	139	559096	84	63198	149
427849	105	532150	81	550282	139	559097	83	63206	149
427856	150	532176	81	550283	139	559098	83	63214	149
427864	104	532192	81	550284	139	559120	131	63222	149
427872	150	532218	81	550285	139	559140	85	63230	149
427880	104	532234	81	550286	70	559390	44	63248	149
427906	104	532242	81	550287	70	559391	45	65326	155
427963	148	532374	74	550288	143	559403	50	68817	151
427971	20	532390	74	550438	59	559439	138	68825	151
428060	103	532416	75	550439	59	559678	56	78006	90
428086	103	532424	82	550440	59	559680	57	78238	90
428102	103	532432	75	550441	59	559681	58		
428128	103	532440	82	550442	59	559683	80		
428144	103	532499	87	550443	59	559684	81		

... IN ALPHABETICAL ORDER

Description	Page
A	
Actuating pin	136
Adapter clamping module B10 to BH5, hydr.	64
Adapter clamping module B10 to BH5, hydr. with indexing	65
Adapter clamping module B10 to BP5, pneum.	66
Adapter clamping module B10 to BP5, pneum. with indexing	67
Adapter for clamping module, mechanical	89
Adapter for height compensation	88
Adapter reduction from KH20, KP20, KP10.3 to B10	86
Adapter reduction from KH20, KP20, KP10.3 to K10, with indexing	87
Adapter set for pull-stud size 10	141, 142
Adapter with external thread	148
Adapter with straight clamp	76
Air gun valve, pneumatic	154
Air-Hydraulic Pump	146
Alignment tool K02 for timing pull-stud	137
Assembly element BH10 and BH20, hydraulic	68
Assembly element BH20, hydraulic, with indexing	69
Assembly element BP10, BP10.3 and BP20, pneumatic	72
Assembly element BP10.3 and BP20, pneumatic, with indexing	73
B	
Base element, flat, for T-slot plate	83
Base element, round, for T-slot plate	84
Base element, with indexing for grid plates	82
C	
Centering sleeve Ø 15	90
Centring pin	90
Centring sleeve, cylindrical	90
Clamping flange, Set	34
Clamping module, mechanical	56, 60
Clamping module, mechanical, screw-in version	54
Clamping module, mechanical, with indexing	57
Clamping module, screw-in version	16
Clamping module, screw-in version, short design	16
Clamping module with locking function, mechanical, screw-in version	55
Clamping module with sensor query for opening and interlock	51, 52
Collet attachment for clamping module KH20 and BH20, hydr.	70
Compact cylinder	30
Compensation pull-stud	135
Counterbalance clamping sleeve	123
Counterbalance element XY-plane	78
Coupling connector	151
Coupling mechanism adapter	144
Coupling nipple adapter	145
Cover caps for clamping module	140
Cover caps for clamping pallets	140
Cover ring for clamping modules	139
D	
Double clamping module, mechanical	58
E	
Engagement screw	131, 133, 135
Engagement screw for protective shield	136
F	
Fastening kit with sensors	50
Fixture plate	112, 118-121
Flow meter	49
Footrest valve, pneumatic	154
H	
Height adjustment element	79
High Pressure Hose	149
Horizontal engagement screw	134
Horizontal rapid-clamping cylinder	28
Hose, pneumatic	153
Hose set, hydraulic	147
Hydraulic tube	149
I	
Indexing T-nut	143
Insertion tool	138
Installation clamping module	19, 20, 22, 24
Installation clamping module, flange version	27
Installation clamping module for automation solutions	41, 42, 43, 46
Installation clamping module for automation solutions, screw-in version	40
Installation clamping module "Gonzales"	202
Installation clamping module, screw-in version	17, 18
Installation clamping module "Unitool"	203
Installation clamping module with central lock for automation solutions	44, 45, 47
Installation clamping module with indexing	19, 21, 25
Installation clamping module with sensor query for opening and interlock	50

Description	Page
Interchangeable pallet	95
Intermediate element	80
Intermediate element, with indexing	81
M	
Manifold	151
Manual directional valve	155
Mounting key for horizontal rapid-clamping cylinder	28
Mounting kit for collet attachment	70
P	
Pipe fittings, brass	148
Pneumatic pressure booster	152
Pneumatic pressure booster set	152
Pneumatic sensor unit, Control and sensor module	48
Positioning pull-stud	137
Pressure intensifier	146
Protective cap	153
Protective shield	136
Puller	137
Pull-stud for T-slots	59
Pull-stud „Gonzales 1000“	204
Pull-stud „Gonzales 2000“	205
Pull-stud key „Gonzales“	205
Pull-stud nut	134
Pull-stud size 10 for M10 engagement screw	128
Pull-stud size 10 for M10 engagement screw with reduced fitting collar	128
Pull-stud size 10 for M8 engagement screw	127
Pull-stud size 10 for M8 engagement screw with reduced fitting collar	127
Pull-stud size 10 for M8 engagement screw without fitting collar	133
Pull-stud size 10 with colour coding for M8 engagement screw	127
Pull-stud size 140	125
Pull-stud size 150	125
Pull-stud size 20 for M12 engagement screw	129
Pull-stud size 20 for M12 engagement screw with reduced fitting collar	129
Pull-stud size 20 for M12 engagement screw without fitting collar	133
Pull-stud size 20 for M16 engagement screw	130
Pull-stud size 20 for M16 engagement screw with reduced fitting collar	130
Pull-stud size 20 with colour coding for M12 engagement screw	129
Pull-stud size 40 for M16 engagement screw	131
Pull-stud size 40 for M18 engagement screw	131
Pull-stud size 5 for M6 engagement screw	126
Pull-stud size 5 for M8 engagement screw	126
Pull-stud „Unitool“	206
Push-in fittings, pneumatic	153
Q	
Quick coupling „flat-face“ G1/4	150
Quick coupling „flat-face“ G1/8	150
Quick fitting coupling, pneumatic	153
S	
Screw-in coupling mechanism	144
Screw-in coupling nipple	145
Sensor module for pneumatic sensor unit	49
Shut-off valve	155
Single clamping bracket	103
Special grease for zero-point clamping modules	155
Spring washer for base element, round	85
Surface-mounted clamping module "Gonzales"	202
Support control, pneumatic	143
Support element, adjustable ± 5 mm	75
Support element, fixed	74
Surface-mounted clamping module	32, 33
T	
T-plug connection, pneumatic	154
Z	
Zero-point clamping sleeve	123
1	
12-point clamping cube	106
2	
2-point clamping bracket	102, 104, 105
2-point clamping station	98, 108, 114
4	
4-point clamping station	95, 98, 100, 109, 112, 115
6	
6-point clamping station	99, 101, 102, 106, 110, 116
8	
8-point clamping station	99

These Terms of Payment apply for companies, legal entities governed by public law and public law special funds. Our goods and services are supplied exclusively on the basis of the following conditions. Any deviating purchasing conditions of the customer not expressly recognised by us will not become part of the contract through acceptance of the order. By placing the order and accepting the goods we deliver, the customer confirms its consent to our terms and conditions.

1. Offer and contractual conclusion

All our offers are always subject to change without notice unless otherwise explicitly agreed. Our delivery contracts are based on the latest version of our catalogue. Dimension and weight values, as well as illustrations, drawings and data, are non-binding and can be changed by us at any time. Therefore, deviations cannot be ruled out and do not justify any compensation claims against us.

Orders are considered accepted only when confirmed by us in writing. If, for organisational reasons, the customer does not receive a separate confirmation upon the delivery of goods, the invoice shall also be deemed the order confirmation.

2. Prices

The prices are in EURO, ex-works, excluding VAT, packing, freight, postage and insurance. Unless otherwise agreed, our list prices valid on the day of delivery shall apply. For orders below 50 EUR goods net, we must make a minimum quantity surcharge of a 10 EURO for cost reasons.

3. Tool costs

Unless any other agreements have been reached, the tools fabricated for the purpose of executing the order shall remain our property in all cases, even if we have invoiced a tool cost component separately.

4. Payment

Unless otherwise stated on the invoice, the purchase price falls due for net payment within 30 days of the invoice date (without deduction of discount). Invoice amounts of below 50 EURO are due for payment immediately.

In case of payment default, we shall be entitled to charge default interest. The amount corresponds to our interest rate for current account credits at our main bank; the minimum however being 8 percentage points above the relevant base interest rate applied by the European Central Bank. Moreover, in case of default following written notice to the customer, we shall be entitled to cease to fulfil our obligations until payments are received.

5. No set-off

The customer can set-off only with legally confirmed or undisputed counterclaims.

6. Right of withdrawal in case of delayed acceptance or payment and insolvency

If the customer fails to accept the goods in due time, we shall be entitled to set a reasonable period of grace, after which we can dispose of the goods elsewhere and supply the customer on a reasonably longer term. Our rights to withdraw from the contract under the provisions of Section 326 BGB and demand damages for non-performance shall not be affected. If the customer fails to pay for the goods once payment is due, we shall be entitled, at the end of a reasonable period of grace we have set, to withdraw from the contract and demand the return of any goods already supplied. Section 323 BGB remains unaffected in all other cases.

If the customer applies for the opening of insolvency proceedings, we shall be entitled, prior to the ordering of security measures by the insolvency court, to withdraw from the contract and demand the immediate return of the goods.

7. Customer-specific fabrications/project fabrications (custom fabrications)

Customer-specific fabrications require binding information on design, quantity etc. in written form at the time of ordering. For manufacturing reasons, we reserve the right to supply up to 10% above or below the order quantity. Technical modifications or cancellations are subject to any costs incurred. The return of customer-specific fabrications is impossible.

8. Delivery and packaging, transfer of risk

The delivery date is non-binding; although stated to the best of our knowledge. It is subject to us receiving correct, defect-free and complete deliveries. The stated delivery dates relate to completion in the factory, starting on the day the order is accepted by us. Delivery is EXW (ex-works) in accordance with Incoterms 2010. Therefore, the costs are borne by the customer. The risk is transferred to the customer when the goods are passed to the person, company or facility nominated to execute the shipment. This applies also for partial deliveries, or if we have assumed responsibility for delivery and installation. The risk shall be transferred to the customer even in the case of delayed acceptance.

In the absence of specific shipping instructions, we shall proceed as we deem fit and without any obligation to the cheapest or most expedient method. The customer agrees that the order can also be delivered in parts, insofar as this is reasonable for the customer. We shall charge a 5 EURO processing free for shipping to third parties that we supply on behalf of the customer.

The packaging complies with the packaging ordinance. Disposable packaging shall be charged at cost price. The packaging cannot be taken back.

9. Performance impediment and/or impossibility

If we are hindered in the fulfilment of our obligation due to the onset of unforeseeable circumstances, which we are unable to avoid despite reasonable effort in relation to the nature of the circumstances (e.g. operational interruption, delay in the delivery of important raw materials, defects in the delivery), the delivery time shall be extended by a reasonable period, insofar as the supply of goods or services is not rendered unreasonably difficult or impossible.

If we have to accept that these circumstances are not only temporary, we shall be entitled to withdraw from the contract either in whole or in part.

If the supply of goods or services becomes impossible, the customer shall not be obliged to furnish its own contractual service. Section 275 BGB applies mutatis mutandis. If, however, the customer is solely or predominantly responsible for the

circumstances that led to impossibility, it shall remain under an obligation to render the return service. The same applies if this circumstance occurs at a time when the customer is behind schedule with acceptance.

10. Samples/returns

Samples shall be provided only against payment. If samples or models are provided, a credit note shall be issued with the subsequent order if the order value is 125 EURO net or more. Goods can be returned only by agreement, although custom fabrications are excluded from such return.

In the case of returns for which we are not responsible (e.g. incorrect order), we shall charge a processing fee of 10%, the minimum value, however, being 7.50 EURO.

11. Retention of title

The goods shall remain our property unless full payment of all claims and/or until the cheques provided for this purpose are honoured. The itemisation of claims in an ongoing invoice, as well as balancing the account and the recognition thereof does not affect the retention of title. The customer is entitled to sell on the retained goods during the ordinary course of business. However, the customer is not permitted to pledge the goods or transfer them by way of security. It shall assign its claim ensuing from the selling on of the retained goods to us in advance. The customer shall be entitled to collect the claim to the extent that it has fulfilled its obligations towards us. At our request, the customer shall be obliged to state third-party debtors and we shall be entitled to report this and the assignment.

12. Property rights

We reserve property rights and copyrights to all contractual documents such as drafts, drawings, calculations and cost estimates. Such documents must not be reproduced or disclosed to third parties without our consent. Any rights to patents, utility models etc. reside solely with us, insofar as such patents have not yet been filed. Our products are allowed to be replicated only with our written consent.

If objects are fabricated according to drawings or samples, the customer shall warrant that any third party property rights are not infringed by manufacture or delivery. If a third party forbids manufacture and delivery on account of property rights, we shall be entitled to stop manufacture and delivery immediately. The customer shall be obliged to reimburse us with all costs incurred and indemnify us from third party compensation claims. Compensation claims by the customer are impossible.

13. Warranty

If the customer agrees with us a particular quality of the goods, we shall base this agreement on our technical delivery specifications. If we have to deliver according to customer drawings, specifications, samples etc., the customer shall assume the risk for suitability for the intended purpose. If, after the contract is concluded, the scope of goods or services is changed at the customer's request and this impairs the quality or suitability of the goods, claims for defects on the part of the customer shall be ruled out, insofar as such impairments are caused by the customer's requests for change.

The time at which the risk is transferred is decisive for the contractual state of the goods. Wear and tear of wearing parts caused by ordinary use does not constitute a defect. Claims for defects are ruled out in the following cases in particular: Unsuitable or improper use, incorrect installation and/or commissioning by the customer or third party, normal wear and tear, incorrect or negligent handling - in particular excessive use -, unsuitable equipment, replacement materials, chemical, electrochemical or electrical influences, unless such defects are caused by ourselves.

If the goods contain a defects, we shall provide, following a reasonable period of grace set by the customer, either a replacement or a repair as we deem fit. If such subsequent performance fails, the customer shall be entitled to either reduce the purchase price or withdraw from the contract. Any further warranty claims are ruled out. In case of negligible deviations from the agreed quality, no claims for defects shall be recognised.

The discovery of defects must be communicated to us immediately in writing. In the case of recognisable defects, however, within 10 days of acceptance, in the case of non-recognisable defects immediately after they become evident. The warranty is 12 months, starting with delivery of the goods ex-works.

14. Liability

With the exception of harm to life, body or health on account of a breach of duty by ourselves, our liability shall be limited to intent or gross negligence.

15. Place of fulfilment, place of jurisdiction and governing law

The place of fulfilment for all obligations ensuing from this contractual relationship is D-70734 Fellbach.

The place of jurisdiction for all legal disputes ensuing from the contractual relationship is the court responsible for the headquarters of Andreas Maier GmbH & Co. KG.

All disputes ensuing from the contract or regarding the validity thereof shall be finally decided by a court of arbitration in accordance with the Court of Arbitration Ordinance of the German Committee for Arbitration Court Procedures or the Conciliation and Arbitration Arrangement of the International Chamber of Commerce, recourse to ordinary courts of law being excluded. The legal dunning process, however, remains permissible.

German law shall govern (BGB and HGB). The applicability of the UN Convention on Contracts for the International Sale of Goods (CISG) is ruled out.

16. Severability clause

If individual provisions become legally invalid, the remaining provisions shall not be affected. The legally invalid provision shall be replaced by regulations that most closely reflect the economic purpose of the contract with reasonable consideration for the mutual interests. The publication of these Terms of Sale, Delivery and Payment renders all previous versions invalid. This does not apply for any contracts concluded prior to announcement.

ZERO-POINT-SYSTEMS CATALOGUE 2023/2024

Request additional catalogues from www.amf.de



ZERO-POINT-SYSTEMS



HYDRAULIC CLAMPING SYSTEMS



VACUUM CLAMPING SYSTEMS

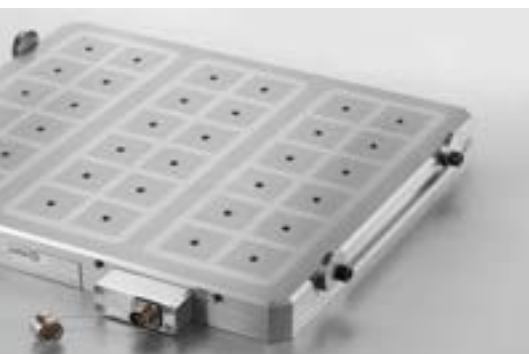

MAGNETIC CLAMPING SYSTEMS



WIRELESS SENSING SYSTEMS



TOGGLE CLAMPS



SINGLE AND MULTIPLE CLAMPING SYSTEMS



STANDARD CLAMPING SYSTEMS



MARKING AND CLEANING TOOLS



ANDREAS MAIER GmbH & Co. KG

Waiblinger Straße 116 · D-70734 Fellbach

Phone: +49 711 5766-0

Fax: +49 711 575725

E-mail: amf@amf.de

Web: www.amf.de

Order no. 189308 · € 3,60