

For NOERDEN SMART WATCH - MATE2 / MATE2+



noerden
User Manual

TABLE OF CONTENTS

▪ Box contents	1
▪ Product Specifications	1
▪ Your watch	2
▪ Quick start with your smartphone	3
▪ Discover the key functions	5
▪ How to change the battery	11
▪ How to change the strap	12
▪ Upgrade your watch firmware	13
▪ Reset	13
▪ Declaration of conformity	13

BOX CONTENTS

- NOERDEN Smart Watch
- Battery CR2032 (pre-installed)
- Professional Watch Case Opener
- Quick Start Guide
- Warranty Card
- Safety Statement

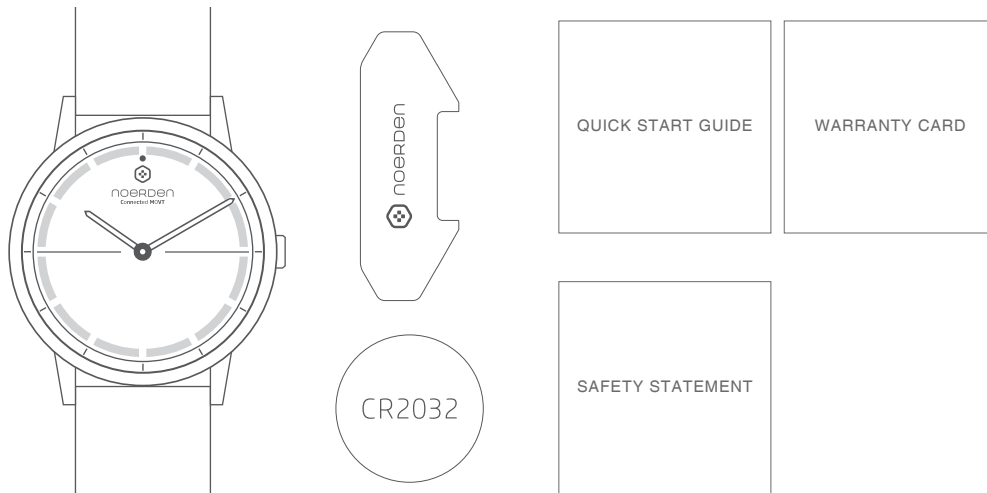

PRODUCT SPECIFICATIONS

NOERDEN Smart Watch MATE2/MATE2+

- 5ATM Waterproof
- Case Diameter: 40mm
- Weight — MATE2: 61.2g
MATE2+: 56.7g
- Strap: adaptable to 150-220mm wrists
- Operating temperature: 0°C- 50°C
- Colors — MATE2: black, white, black & white
and white & black
MATE2+: black and khaki

Sensors & Technology

- Quartz Oscillator
- Activity G-sensor: day and night movement sensor
- Indicator Light

Connectivity & Compatibility

- Connectivity: Bluetooth 4.1
- Compatible Devices: iPhone 6 and above, Android devices
- Operating Systems: iOS 11.0, Android 6.0 and above

Battery

- Battery Type: button battery CR2032
- Normal Capacity: 240mAh
- Input: 3V \approx 0.2mA

Smart Functions & Data

- World Time Synchronization
- Camera Remote
- Music Control
- Activity Tracking
- Sleep Monitoring
- Personal Goal Tracking
- Find My Phone
- Vibration Notifications
- Call Rejection
- Silent Alarm
- Do Not Disturb
- HIIT Workout & Multi-sport Functions

YOUR WATCH



QUICK START WITH YOUR SMARTPHONE



Scan the QR code to download the NOERDEN App or search for NOERDEN in the App Store or on Google Play.

● TURN ON YOUR WATCH

Press and hold the button for 3 seconds. The indicator light will flash quickly and the watch will vibrate. After that, your watch is automatically switched on.

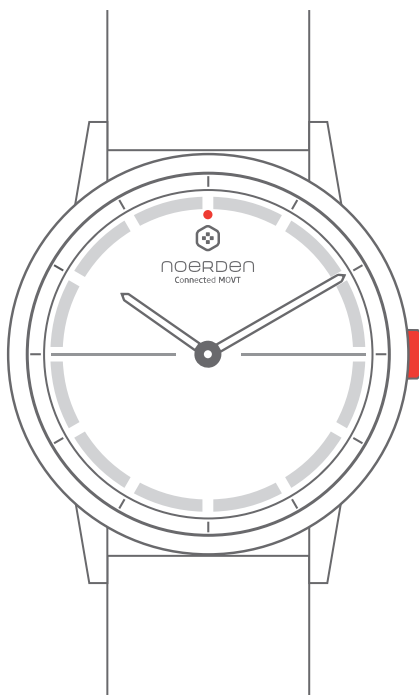

Press and hold the button for 3 seconds



The indicator light flashes red and the watch vibrates

→ ON

● CONNECT TO THE NOERDEN APP

1. Turn on your phone's Bluetooth and hold your watch close to the phone until the device is connected.

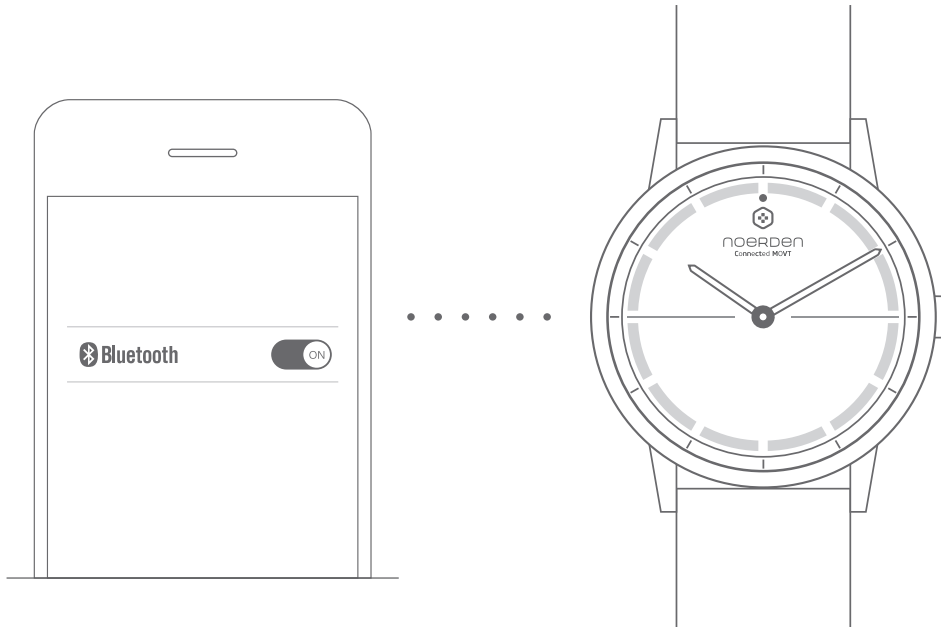

2. In the NOERDEN App, go to the 'Device' page and click 'Add a new device'. Follow the instructions: find your watch 'NOERDEN-MW' and connect it.

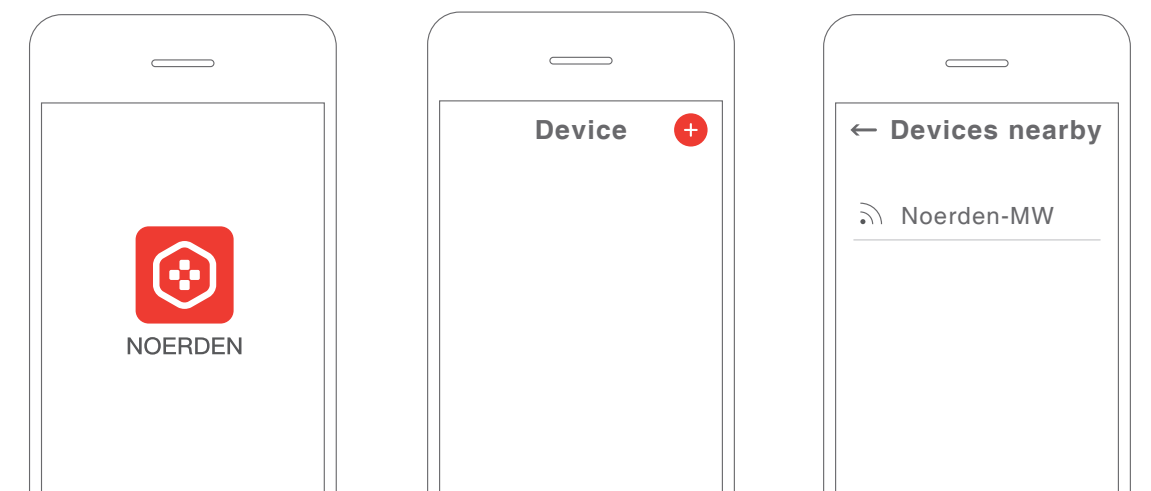

● TIME CALIBRATION

When using your watch for the first time, you need to set the time of your new watch.

1. In the NOERDEN App, go to the 'Device' page and then click 'Smart Time Calibration'.
2. Enter the time displayed on your watch onto your phone's interface. The time will then automatically calibrate.

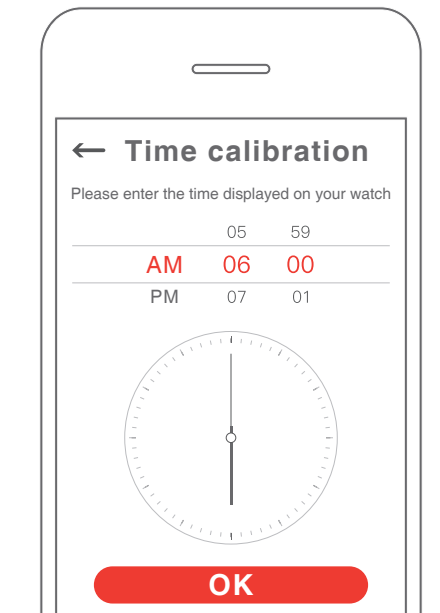

DISCOVER THE KEY FUNCTIONS

Bluetooth

Press the button to check the Bluetooth status of your watch.



The indicator light flashes red
→ Bluetooth is disconnected



Indicator light is green
→ Bluetooth is connected



Disable Bluetooth Mode

The watch automatically starts Disable Bluetooth Mode when the bluetooth is disconnected for more than 2 hours, meaning Bluetooth is off.

You can also manually enable the Disable Bluetooth Mode in the App.

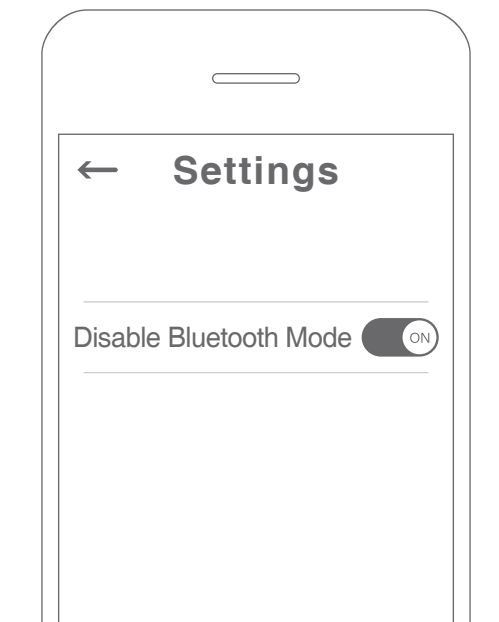

Note: When you press the button once to check the Bluetooth status, Bluetooth will automatically switch on and your watch will reconnect to your phone if it was in Disable Bluetooth Mode.



Find My Phone

Double press the button and your phone will ring.

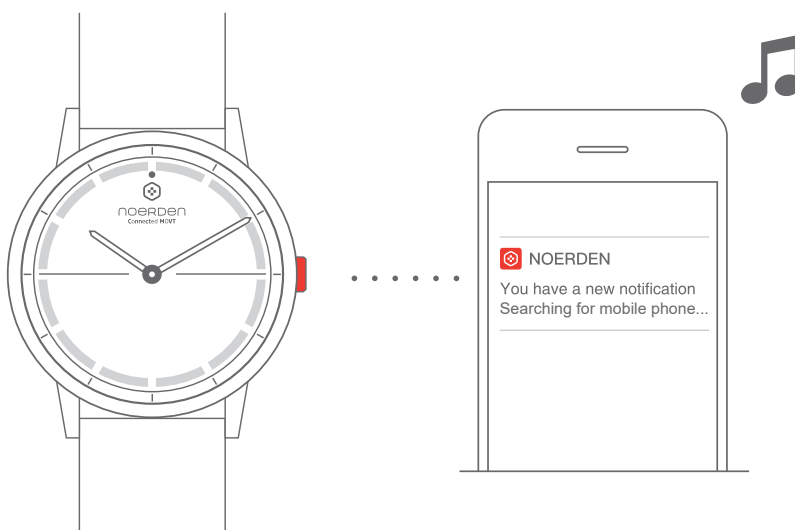

Note: Your watch must be connected to your phone via Bluetooth. If your phone is on Silent Mode, it will only vibrate.



Call Alert and Rejection

Call Alert



when you receive a call, the indicator light will flash in green and your watch will vibrate for 5 seconds

Call Rejection

To reject the call, press the button once. The indicator light will flash in red once and your watch will vibrate once.



Your watch will vibrate and the indicator light will flash red once.

Note: your watch must be connected to your phone via Bluetooth. This function must be switched ON in the 'Device' menu of the NOERDEN App and you must accept the access.



Messages and Notifications

When you receive a message or notification, the indicator light will flash in green once and your watch will vibrate once.

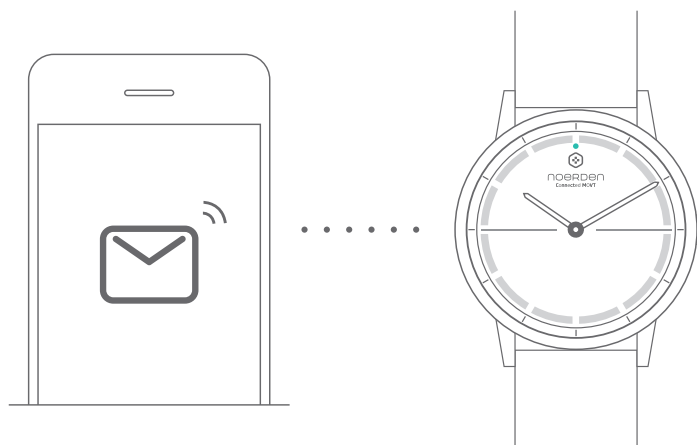

Your watch vibrates and indicator light flashes green once.

Note: your watch must be connected to your phone via Bluetooth. This function must be switched ON in the 'Device' menu of the NOERDEN App and you must accept the access.



Silent Alarm

To wake-up gently, you can set a silent alarm time on the NOERDEN App. Your watch will vibrate for 8 seconds. To turn it off, press the button once. The indicator light will flash once in red and your watch will vibrate once.

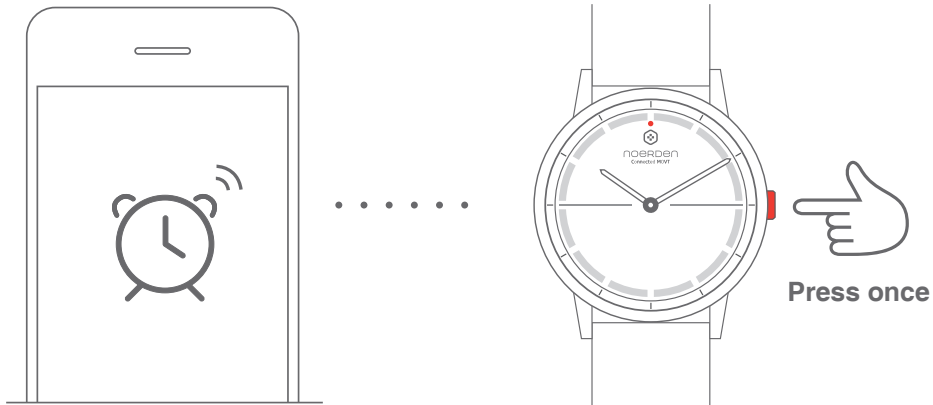

 ...   **Your watch will vibrate and the indicator light will flash red once.** → **Turn off Alarm**

Note: Your watch must be connected to your phone via Bluetooth. This function must be switched ON in the 'Device' menu of the NOERDEN App.



Do Not Disturb

In 'Do Not Disturb' Mode, all calls and notifications – except alarms, will be silenced. The default time is set from 11pm to 6am or you can change it in the '**Do Not Disturb**' page in the NOERDEN App.



Note: Your watch must be connected to your phone via Bluetooth. This function must be switched ON in the 'Device' menu of the NOERDEN App.



Camera Remote

In the NOERDEN App, go to the "Device" menu and then "Camera Remote". A camera page will open. Shake your watch or press the button to take a picture.

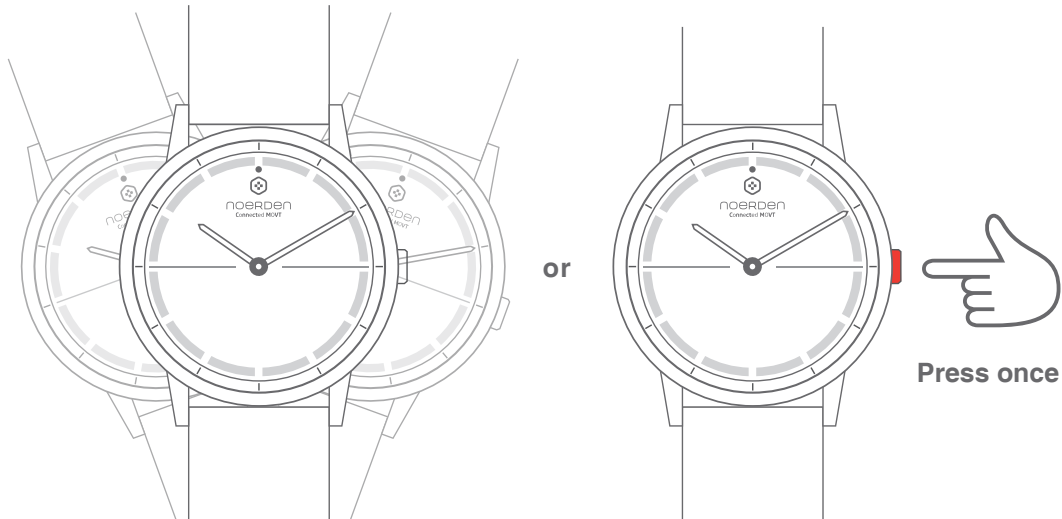

Note: Your watch must be connected to your phone via Bluetooth, and you must accept NOERDEN App to access your phone's camera.



Music Control

In the NOERDEN App, go to the 'Device' menu to switch on the Music Control function. After that, you can tap your watch glass to control your music play.

Tap the glass twice → Play the next song

Tap the glass three times → Play previous song



Note: Your watch must be connected to your phone via Bluetooth and you must accept the NOERDEN App to access your music apps.

Battery

You can check the battery level of your watch in the 'Device' menu of the NOERDEN App. When your watch's battery is low, if you press your watch button, the indicator light will flash in red for 5 seconds and all smart functions will be turned off.



The indicator light flashes red for 5 seconds

HIIT Workout & Multi-sport Functions

Go to the Training page in the NOERDEN App and select the activity of your choice (running, cycling, HIIT, yoga...).

After your session is complete, you will be able to consult your activity detailed data (distance, duration, calories...)

HIIT & Yoga

For HIIT or Yoga workouts, you can pick between different pre-set programs, exercises, intensity levels and durations.

You can also personalize your own session by using the customize option where you can set your preferred exercise/rest intervals/repetitions.

- Once you're all set, click the "Start" button on the App. Your watch will vibrate 5 times and the training session will begin.
- Your watch will vibrate 3 times when each time interval finishes, to indicate a change in exercises or rest time.
- It will vibrate 5 times when your training session is complete.

Multi-sports

For sports such as running or cycling, simply follow the instructions in the App.

At the end of your training, you will be able to consult the route covered on a map in addition to your detailed activity data

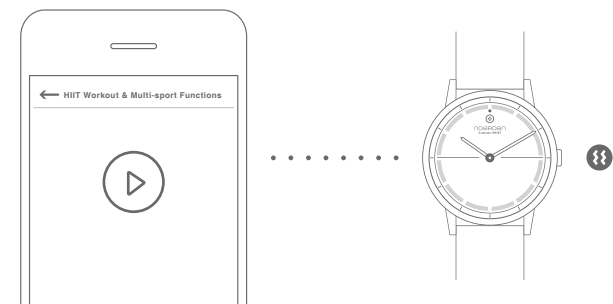

NOTE:

- Your watch must be connected via Bluetooth.
- Please make sure to keep your phone within a 10 meters distance from your watch for vibrations to work.
- Please make sure to keep your phone with you for activities with GPS tracking otherwise you can't get your route map in the end.

HOW TO CHANGE THE BATTERY

When the battery is low, your watch's Bluetooth is automatically turned OFF. To continue to enjoy all smart functions, you should change the battery as soon as possible.

We recommend you to go to a local watch shop to replace the battery CR2032. If you wish to do it yourself, you can follow the instructions below.

1. Open the watch case with the professional case opener.

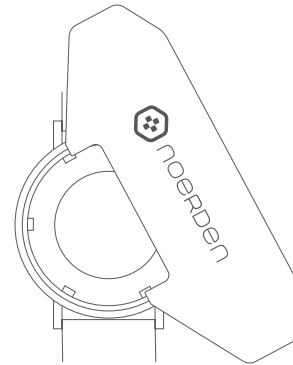

2. Take off the battery retainer.

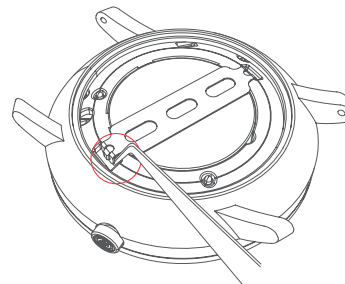

3. Take out the old battery by using tweezers or a flat tool thinner than 2mm, carefully lift and remove the battery

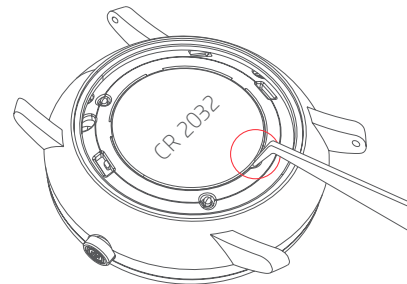

4. Install the new battery (CR2032) in the same way as removing it. Once it is properly installed, the indicator light will flash red once

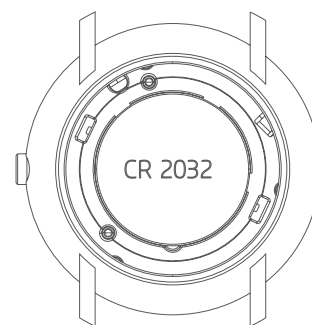

Indicator light flashes red once

5. Use a sharp headed tool to gently press the reset button once, the indicator light will then flash green once.

6. Use the same method to put the battery retainer back in.

7. Install the watch case and turn it until it's tight. You can then use your watch normally again!

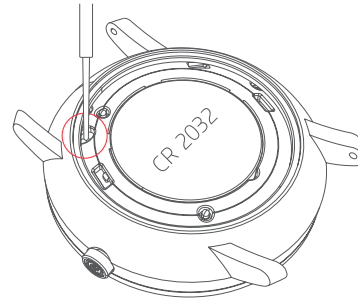

Indicator light flashes green once

Note:

- The warranty will be void if the battery was not changed by a professional and water damage occurs.
- If you get your battery changed by a professional, please keep the receipt as proof.
- When changing the battery yourself, make sure to close the case properly. If closed improperly, you risk impairing the watch's waterproof resistance.
- We suggest that you synchronize the data before changing your battery, in case of data loss.

CAUTION

**RISK OF EXPLOSION IF BATTERY IS REPLACED BY AN INCORRECT TYPE.
DISPOSE OF USED BATTERIES ACCORDING TO THE INSTRUCTIONS.**

HOW TO CHANGE THE STRAP

1. Move the quick release spring bar to remove the strap.

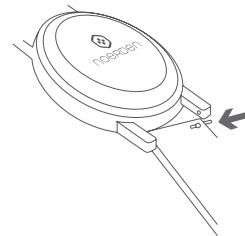

2. Take your new strap and insert one side of the spring bar into the lug end.

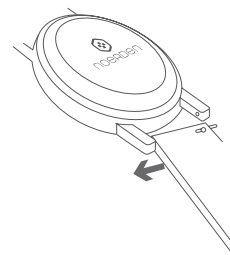

3. Push the spring bar into the other side, your new strap is installed!

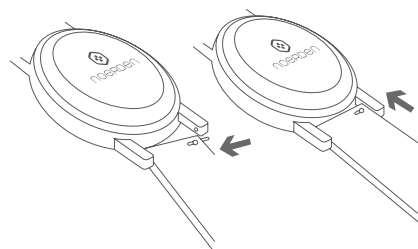

UPGRADE WATCH FIRMWARE

1. To update your firmware go to the NOERDEN App > Profile > Settings > Check for firmware upgrade.
2. Your phone will download the new firmware version and upload it to your watch.
3. During the installation, the indicator light of your watch will continuously flash in red.
4. When the indicator light stops flashing, the firmware has been upgraded successfully.
5. Check if the time of your watch is accurate, otherwise perform the time calibration.

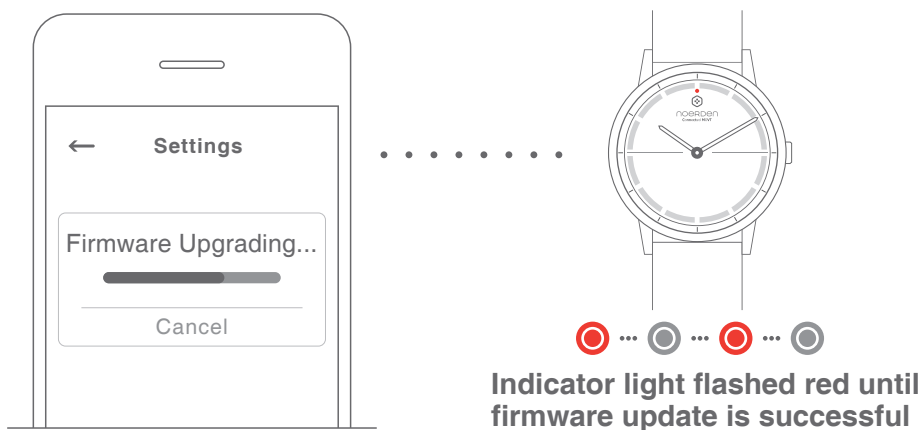

RESET

Press and hold the button for 6 seconds. The indicator light will flash in red once and the process will start.

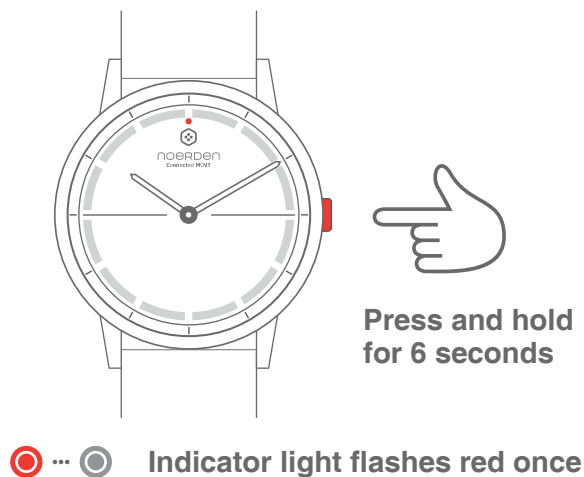

Note: If you reset your watch to factory mode, it may delete all your data. You will have to restart your watch after the restoration.

DECLARATION OF CONFORMITY

The undersigned, Noerden (Shanghai) Information Technology Co., Ltd declares that the electrical radio equipment types of the Noerden Smart Watches, Models MATE2/MATE2+, comply with the 2014/53/EU directive.

The complete text is available at www.noerden.eu/support

 www.noerden.eu

For more information,
go to the FAQ page
in the App or on our website