



Model no. VB-6000SE/6100SR

VB-6000SE (Elongated)

VB-6100SR (Round)



Features

- UV LED
- Heated Seat
- Eco-friendly Power Save
- 3 in 1 Full Stainless Nozzle
- Warm Air Dryer
- Self Cleaning Nozzle
- Soft Close
- Posterior Wash / Feminine Wash / Turbo Wash / Rhythm

Required Electrical Service

- 230V / 60Hz

Codes / Standards

- UKCA Certificate
- cETL Certificate
- CE Certificate
- GB Certificate



Included Components

- Template
- Remote Control
- Manuals
- Hose
- T-valve
- Base Bracket X 1
- Bolt Bracket X 2
- Screw M/S X 2
- Insert Rubber Nut X 2
- Washer X 2
- Battery X 3

Notes

- Install this product according to the installation instructions.

Elongated

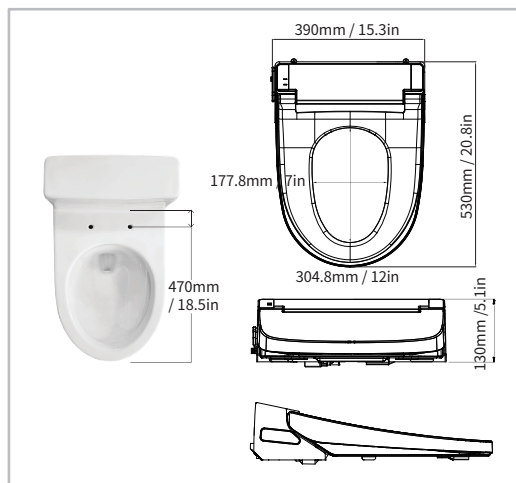

Round

