

**MODEL NUMBER:**

- 1660900.002 Canis Shower Kit with Pressure Balance Cartridge

**PRODUCT FEATURES**

**Ceramic Disc Mixing Valve:** Assures a lifetime of drip-free performance and smooth handle operation.

**Ceramic Balancing Spool:** Maintains a constant output temperature in response to changes in relative hot and cold supply pressure. Ceramic material is unaffected by mineral deposits and harsh water conditions.

**Integrated Check Valves:** Engineered to eliminate cross flow.

**Adjustable Hot Limit Safety Stop:** Limits the amount of hot water allowed to mix with cold. Reduces the risk of accidental scalding.

**Comfort Zone:** Offers a wider shower range to fine tune the desired temperature within the useful temperature zone.

**GENERAL DESCRIPTION**

**Double Ceramic Pressure Balance Cartridge:** Features one-piece design with ceramic discs and ceramic balancing spool. Includes integrated check valves and hot limit safety stop. Cartridge is back to back capable. Ceramic balancing spool maintains constant output temperature in response to changes in relative hot and cold supply pressure. Washer-less ceramic discs provide smooth handle movement and are unaffected by harsh water conditions.

**Trim:**

- 11" Thin profile shower head
- 18" Shower arm with round flange
- Optional 3" ceiling arm with round flange
- 2-way in-wall diverter valve with trim kit
- 30" shower rail
- 60" hose
- 4-function hand shower
- Pressure balance trim kit
- Universal rough-in valve with 1/2" NPT & Sweat connection
- Flow rate: 2.5 gpm/9.5L/min



**Thermal Shock Protection**

VALVE MAINTAINS SHOWER'S WATER TEMPERATURE IF SUDDEN CHANGES IN WATER PRESSURE OCCUR



Reliable For Life



**Guaranteed Not To Leak**

CERAMIC DISC VALVE



Reliable For Life



**Beautiful & Tough**

TARNISH, SCRATCH AND CORROSION RESISTANT FINISH



Reliable For Life

**SUGGESTED SPECIFICATION:**

Shower fitting shall feature 4-function hand shower with 11" showerhead with Max. 2.5 gpm/9.5 L/min. flow rate. Shall feature double ceramic pressure balance cartridge. Cartridge is capable of back to back installation and shall feature integrated check valves to eliminate cross flow. Cartridge shall also feature hot limit safety stop. Fitting shall be: American Standard - Trim Kit Model #1660900.002.

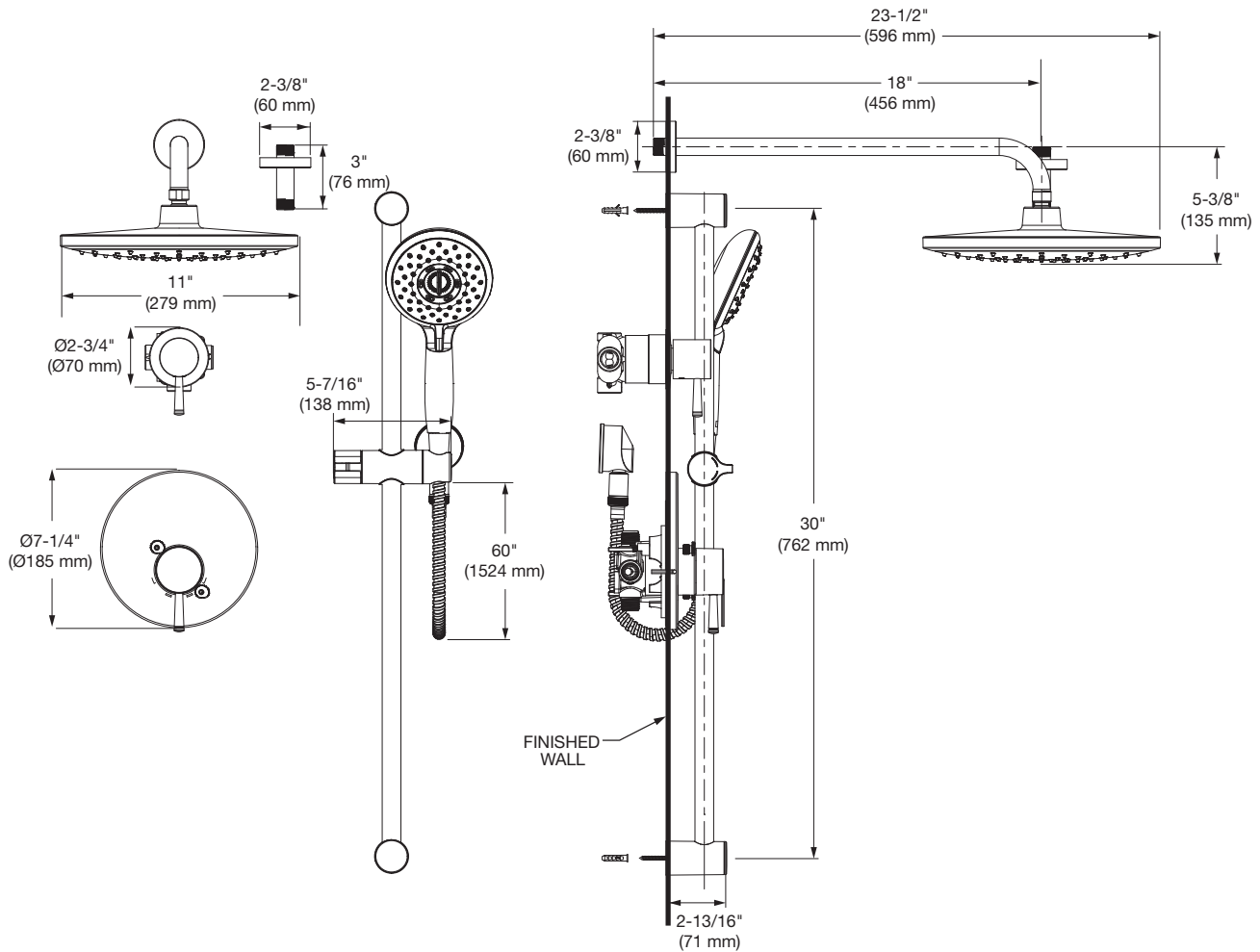

**CODES AND STANDARDS**

These products meet or exceed the following codes and standards:

**ASSE 1016 / ASME A112.18.1016 / CSA B125.16**  
**ASME A112.18.1 / CSA B125.1**

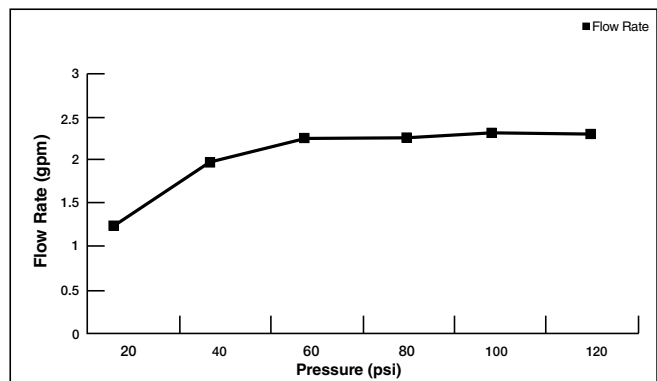

Product Number	Description
1660900.002	Shower Trim Kit. Metal lever handle. 4-Function handshower. Includes cartridge and valve body. Polished Chrome finish.