

DV160 | Heat Recovery Ventilator

Cyclone[®]
Breathe Better

HRV

The Cyclone DV160 mini heat recovery ventilator (HRV) is designed to continuously remove stale air from any space while simultaneously bringing in fresh air from outside. This air exchanger is a simple and efficient air recovery ventilator, perfect for large rooms such as lofts, condos or small commercial spaces. The DV160 complements any style office or home while saving energy costs. Easy to install, simply drill two 5" diameter holes through an exterior wall, connect the damper to the unit, and plug in. Get an HRV for any individual room without the cost and hassle of redoing your entire furnace.

Benefits

- Energy efficient, unit operates with very low energy consumption
- Easy to install and maintain
- Durable, long-lasting construction
- Continuous operation, consistently exchanges stale polluted air for clean oxygen-rich air
- Suitable for apartments, hotels, cottages, small offices, and commercial spaces
- Save money on heating & cooling costs
- Can be used for any room with an exterior wall
- Ideal for spaces up to 1100 sqft



FRONT

BACK



EXTERIOR REAR

Features

- Two axial fans powered by energy efficient EC-motors
- Motors designed for continuous operation and have thermal overheating protection
- Two removable and washable MERV 8 filters that collect dust and pollen from the air
- Special thermostat which prevents condensation from freezing
- Removable bottom tray collects moisture
- Remote mechanical three-speed switch for easy use
- Twin exterior ventilation hood included
- Two 5" diameter x 19 3/4" long ducts (trimmable)
- Recommended maximum duct run - 25'

Cyclone Range Hoods Inc.

1361 Huntingwood Drive, Unit 16, Toronto, ON, M1S 3J1, Canada.

Toll Free: 1-888-293-5662 Tel: (416) 293-0933 Fax: (416) 293-4793 Website: www.CycloneRangeHoods.com

DV160 | Heat Recovery Ventilator

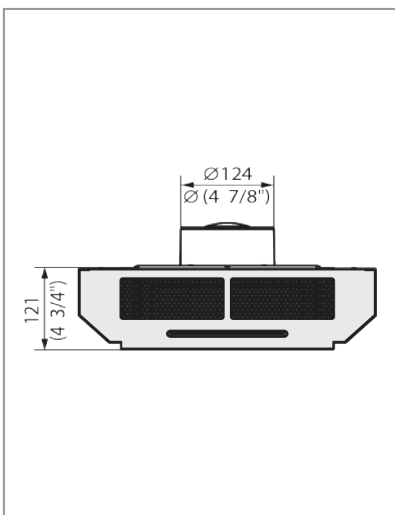
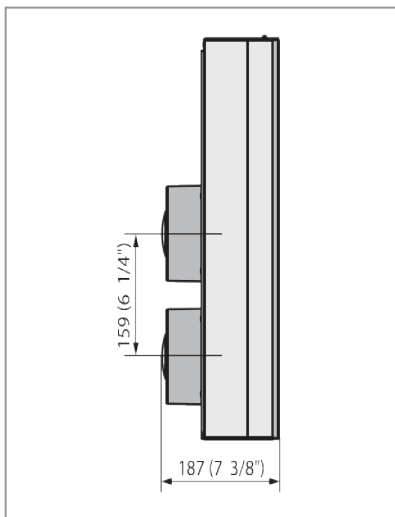
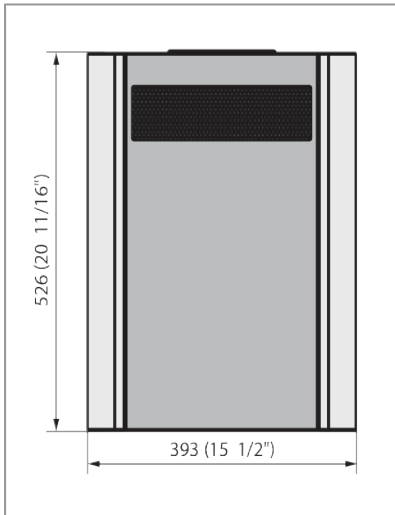

Model	DV160		
Speed	1	2	3
Electrical Connection (V/Hz)	100-240/50-60		
Power Consumption (Watts)	4.2	9.6	15.4
Current (Amps)	0.02	0.04	0.07
Air Flow Volume (CFM)	17.7	26.5	35.3
Fan Speed (RPM)	1165	1720	2685
Sensible Recovery Efficiency	79	74	70
Noise Level (Sones)	0.38	0.42	1.00
Ingress Protection Rating (IP)	22		
Operating Ambient Temperature (°C)	+1 to +40		
Transported Air Temperature (°C)	-20 to +50		
Finish	White		

