

ASSEMBLY, MAINTENANCE, & **USER MANUAL**

MODEL #SSASN100

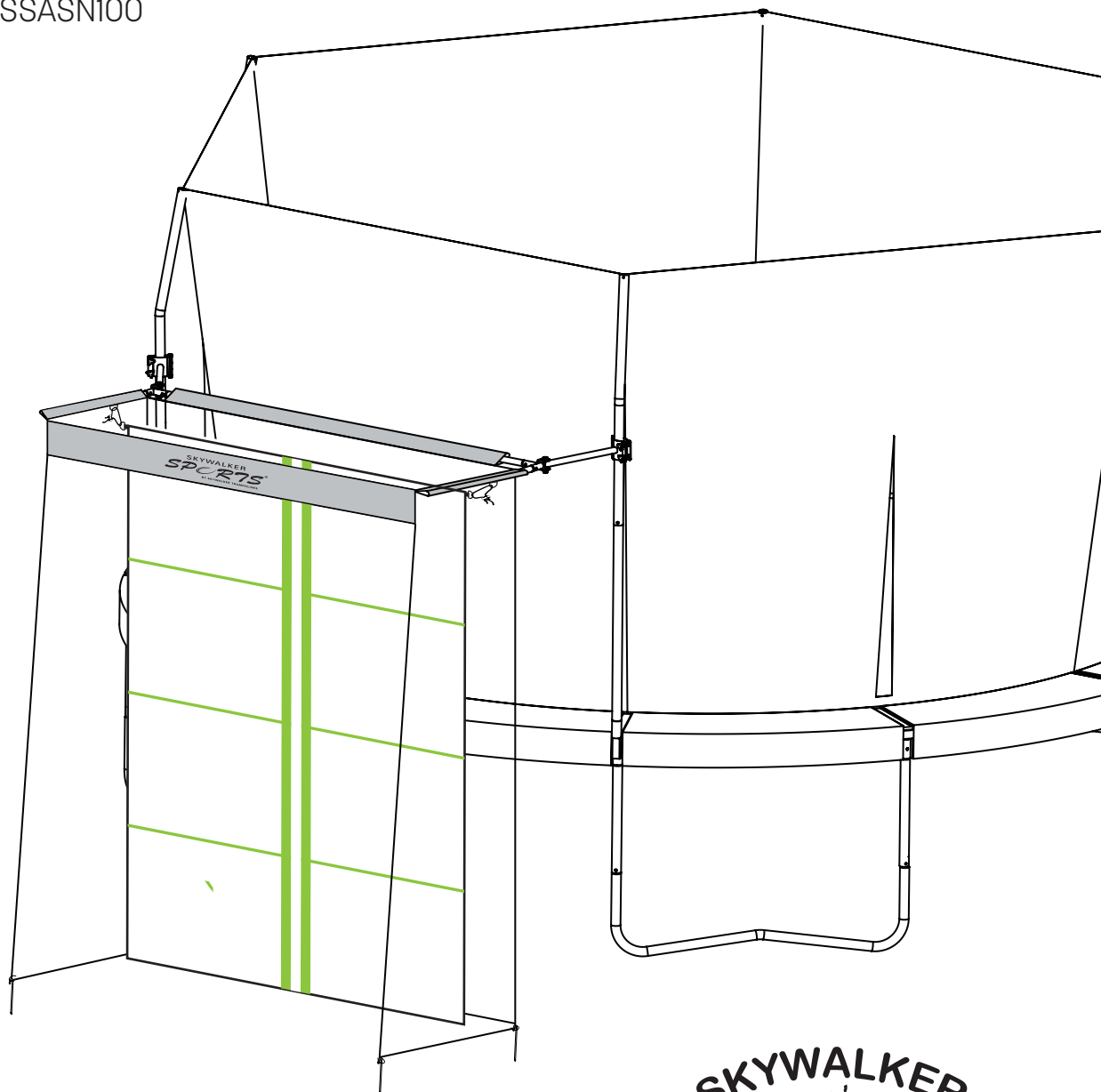

WARNING

Read all precautions and instructions in this manual before using this equipment. Save this manual for future reference.

Skywalker Trampolines Patent: US RE45,182 E
US 7,481,740 B2

SKYWALKER

TRAMPOLINES

Skywalker Holdings LLC
P.O. Box 574, Brigham City, UT 84302

TABLE OF CONTENTS

Part List.....	3
Part Identification.....	4-5
Exploded Drawing.....	6
Assembly.....	7-14
Limited Warranty.....	15



STOP EVERYTHING YOU'RE DOING AND REGISTER YOUR PRODUCT

Find our warranty registration online by typing in: www.skywalkertrampolines.com/registration/

You'll need to have the following information handy:

- Name
- Address
- Phone number
- Date of purchase
- Email address
- Product model number
- Product serial number
- Retailer the product was purchased from

HEY WE'VE GOT SOMETHING REALLY IMPORTANT TO SAY

Skywalker Trampolines belongs to a family of brands focused on providing active products. We've got **assembly videos** (for those of you who prefer movies over books), **FAQs** (in case you have a question that someone else has already asked), **additional products** (including trampolines, playground sports, and fitness equipment), and most importantly, find us on social media! Because we want to be your friend. **We'd love to hear from you, friend.**



@skywalkertrampolines



skywalkertrampolines



@skywalker_trampolines



@swtrampolines



@swtrampolines



www.skywalkertrampolines.com



IMPORTANT

Trampolines and enclosures are susceptible to winds. Be sure to secure your trampoline and enclosure. Wind damage is not covered in the warranty of your trampoline.



WARNING

CHOKING HAZARD- Small parts not for children under 3 years.



WARNING

Adult assembly required.

PART LIST

Key No.	Qty.	Description
1	2	Connect tube
2	2	Front tube
3	2	Corner socket
4	2	Straight tube
5	1	Middle tube
6	1	Net
7	1	Target
8	2	Cinch with cord
9	8	Screw (2 spare parts)
10	4	M8x35mm Bolt
11	4	M8 Wing Nut
12	4	Bolt cap
13	2	M8x50mm Bolt
14	4	M8 Washer
15	2	M8 Nut
16	6	Metal stake
17	2	End Cap
18	2	Foam
19	2	Cap
20	2	Wrench
21	1	Screw driver

ORDERING REPLACEMENT PARTS

We get it, sometimes things happen. But the fun shouldn't stop just because you need a new bolt or screw! To order replacement parts, check out our website at: www.skywalkertrampolines.com or call our toll-free Customer Care Hot-line at **1-866-603-Jump (5867)**, Monday - Thursday, 8 a.m. until 5 p.m. and Friday, 8 a.m. until 3 p.m. Mountain Time (excluding holidays).

Our customer service team will ask you a few questions in order to get the replacement part sent out as soon as possible. We're not trying to complicate your life, we promise.

When calling, make sure to have the following information ready:

- The model # of the product (see the front cover of this manual)
- The key # and description of the part (see the part list above)
- The quantity needed (only you know the answer to that one!)

BEFORE YOU BEGIN

Thanks for choosing Skywalker Trampolines! We're just as excited as you are to help your family live an active (but most importantly **FUN**) lifestyle. This model is one of our favorites, and we're confident you'll love it too. To make things easier for you, we've listed important information that you (and your little outdoor adventurers) need to know. Make sure you brush up on the warnings, instructions, assembly, maintenance, and use of your new product... because there will be a pop quiz at the end! (Okay, not **REALLY**, but if you're still reading this, props to you! You're awesome).

PART IDENTIFICATION

Before you begin, take a look at the drawings below to make sure you have all the parts! The numbers in the squares to the left (key numbers) will help you identify the parts during assembly.

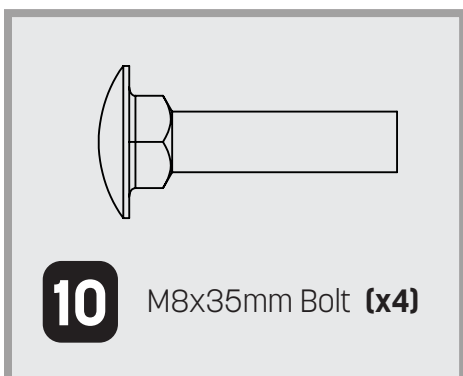
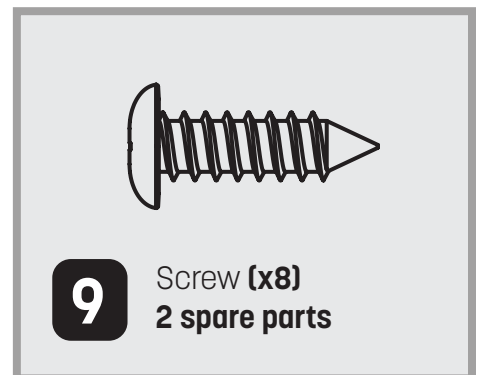
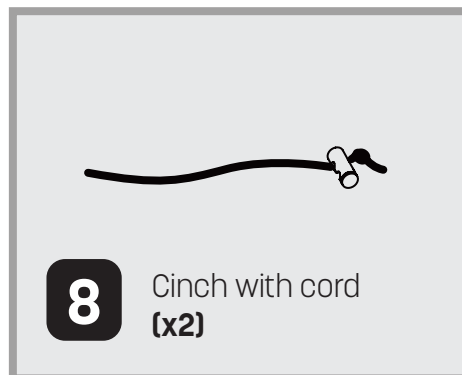
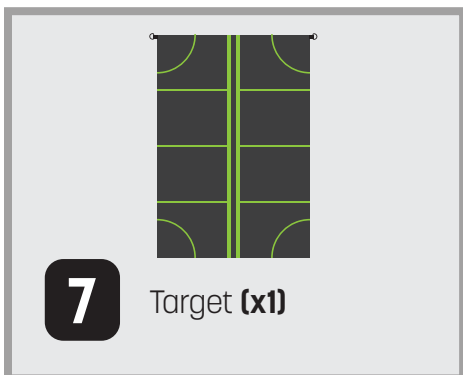
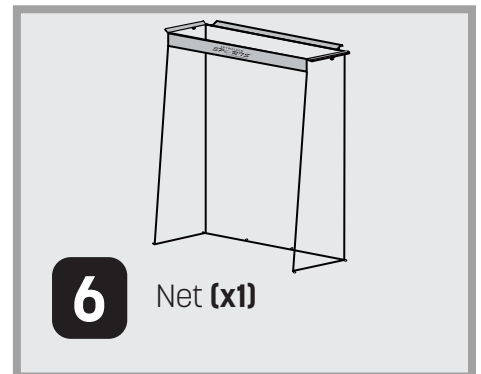
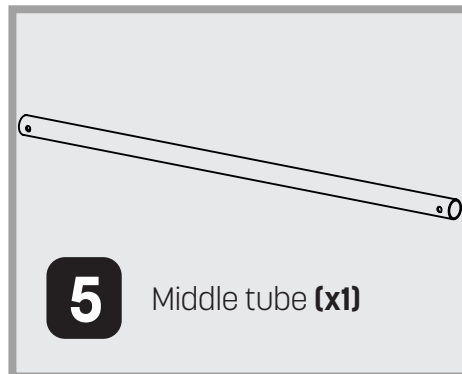
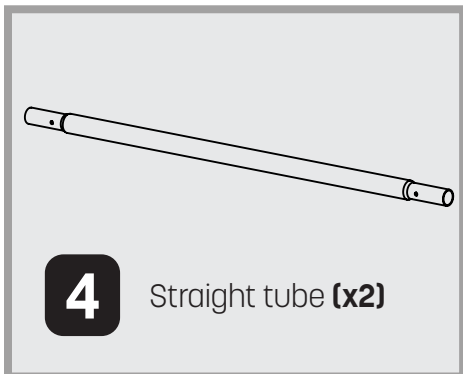
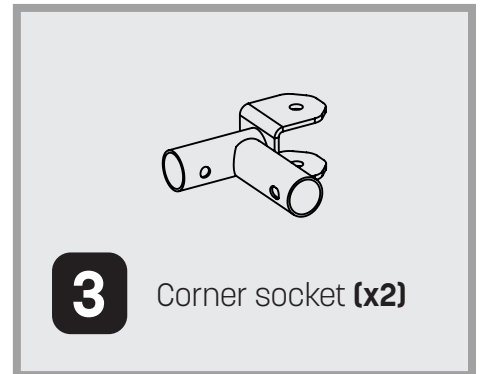
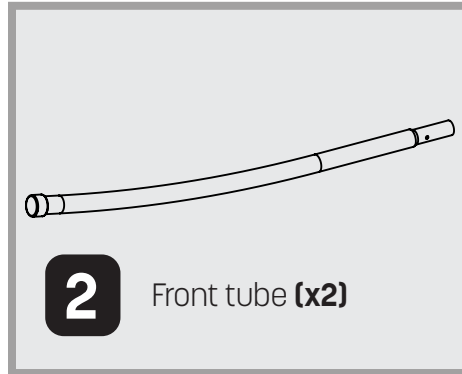
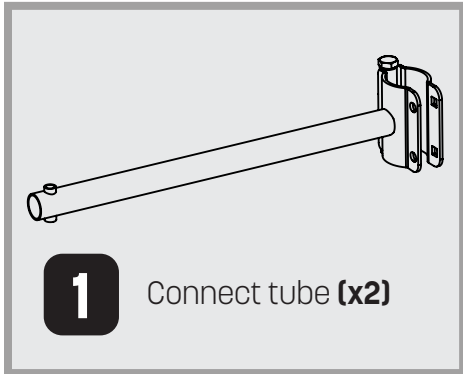

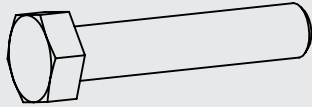

13 M8x50mm Bolt (x2)



14 M8 Washer (x4)

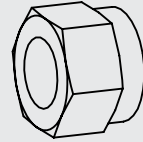

15 M8 Nut (x2)

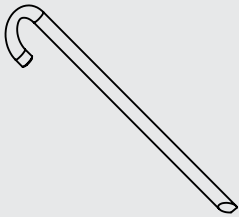

16 Metal stake (x6)

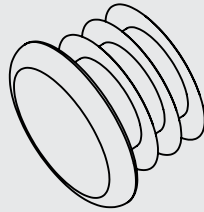

17 End cap (x2)
Pre-installed

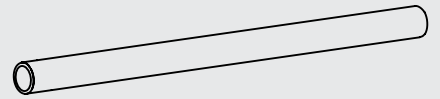

18 Foam (x2)
Pre-installed

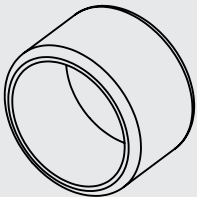

19 Cap (x2)
Pre-installed

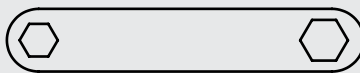

20 Wrench (x2)

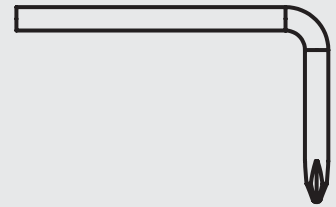

21 Screw Driver (x1)

EXPLODED DRAWING

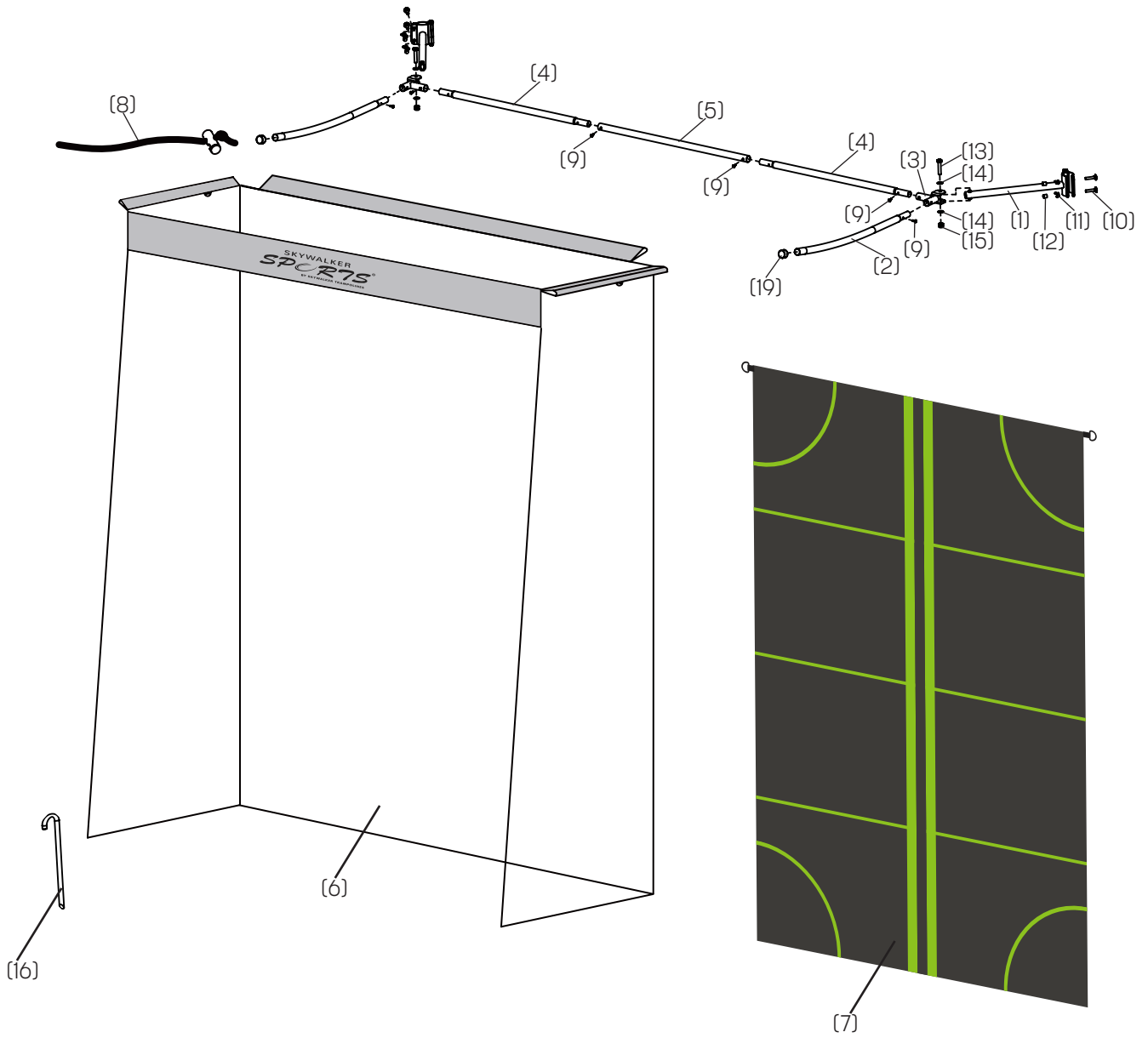

ASSEMBLY

READ THIS BEFORE YOU BEGIN

- We've provided a Phillip's screw driver to help with assembly, but you're more than welcome to use your own tools.
- Use gloves to protect your hands from pinch points during assembly. Plus, it's an up-and-coming fashion trend.
- The assembly steps refer to parts by their descriptions and key numbers (see the part list on page 3).
- The assembly steps are written in a specific order, and if you don't follow them exactly... you may end up having to start all over again.
- Most importantly... YOU'VE GOT THIS. YOU'RE THE BEST ASSEMBLER AROUND. This may not be the easiest thing you've ever done... but it will be **worth it**. Trust us.

And if you're a visual learner, check out our assembly videos!



skywalkertrampolines

STEP 1

Register your Sports Net! For info on **warranty registration**, see page 2.

STEP 2

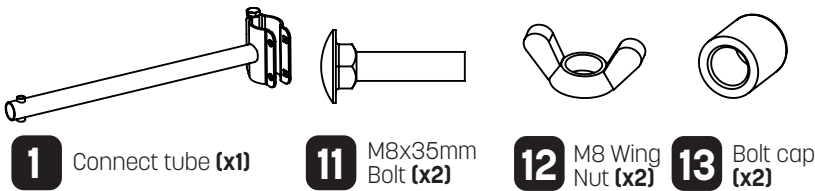

Attach one connect tube **(1)** to one enclosure pole, approximately 1900mm (6.2 ft) from the ground, secure with two bolts **(11)**, and M8 wing nuts **(12)**. Then place the Bolt cap **(13)** onto the end of the bolt.

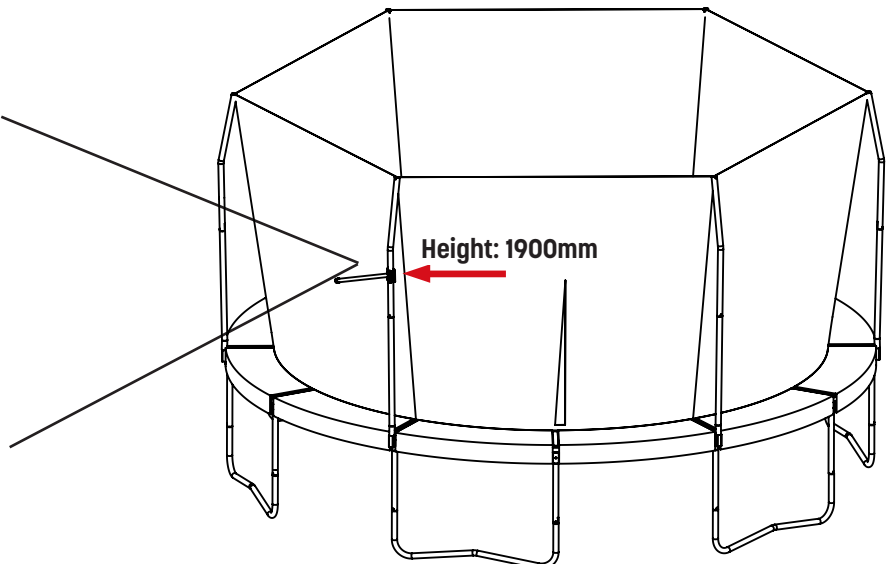
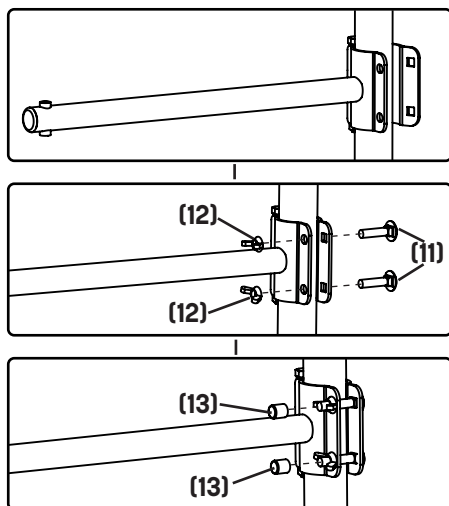

ASSEMBLY

STEP 3

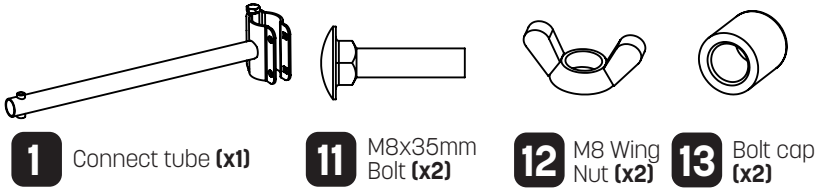

Attach another connect tube **(1)** to the next enclosure pole, making the height 1900mm (6.2 ft) from the ground as well. Secure with two bolts **(11)**, 2 M8 wing nuts **(12)**. Then put the Bolt cap **(13)** onto the end of the bolt.

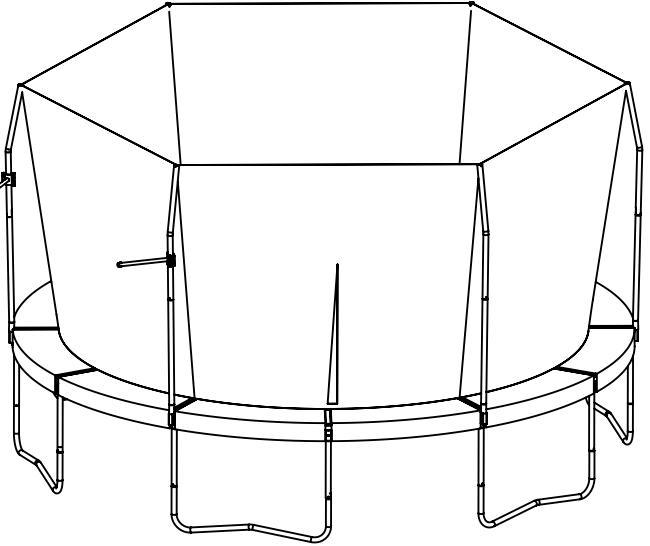
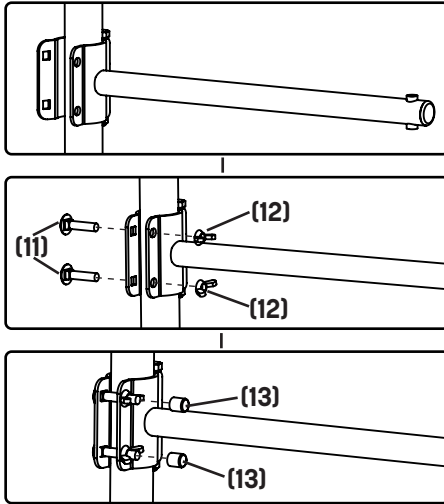

STEP 4

Adjust the distance between the two connect tubes to 2030mm (6.7 ft).

Note: Tighten all four bolts.

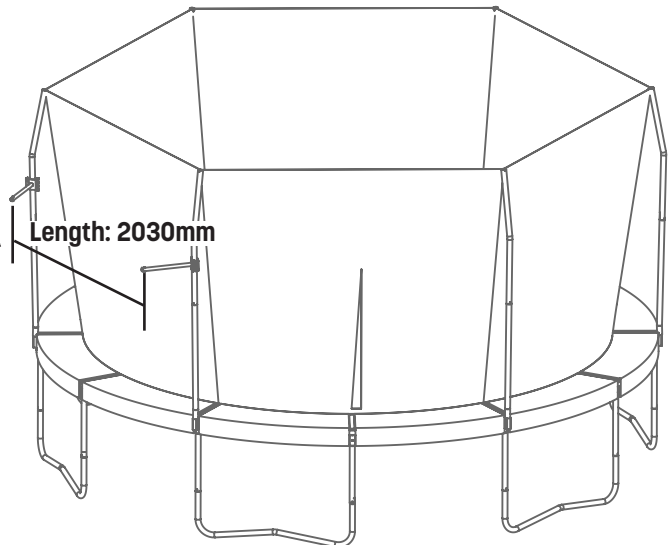
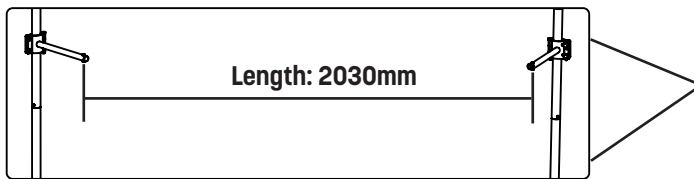

STEP 5

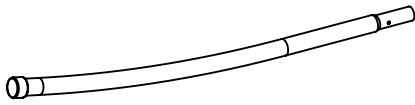

2 Front tube (x1)

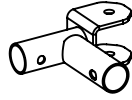

3 Corner socket (x1)

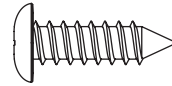

9 Screw (x1)

Insert the front tube **(2)** into corner socket **(3)**, secure with screw **(9)**.

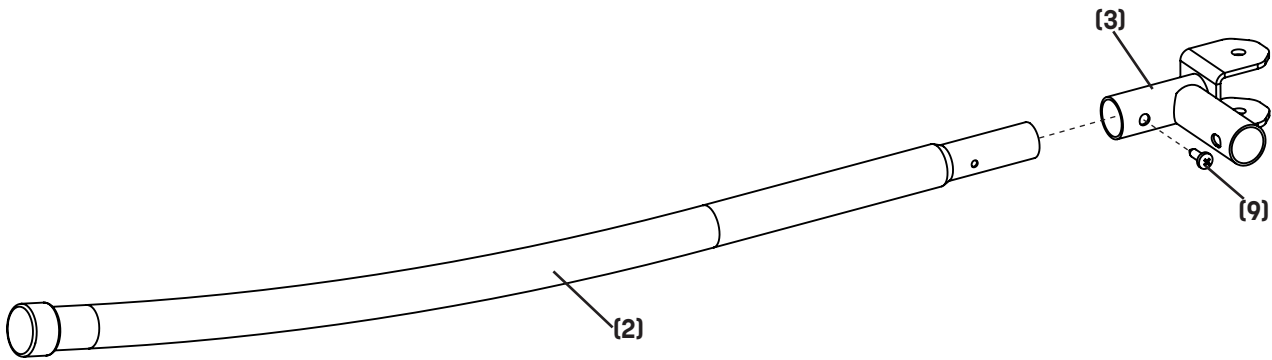

STEP 6

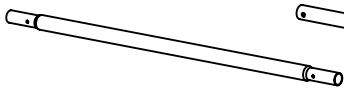

4 Straight tube (x2)

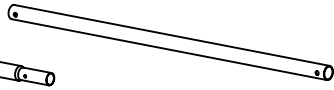

5 Middle tube (x1)

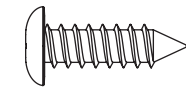

9 Screw (x2)

Attach two Straight tubes **(4)** to the ends of the Middle tube **(5)** as shown, secure with screws **(9)**.

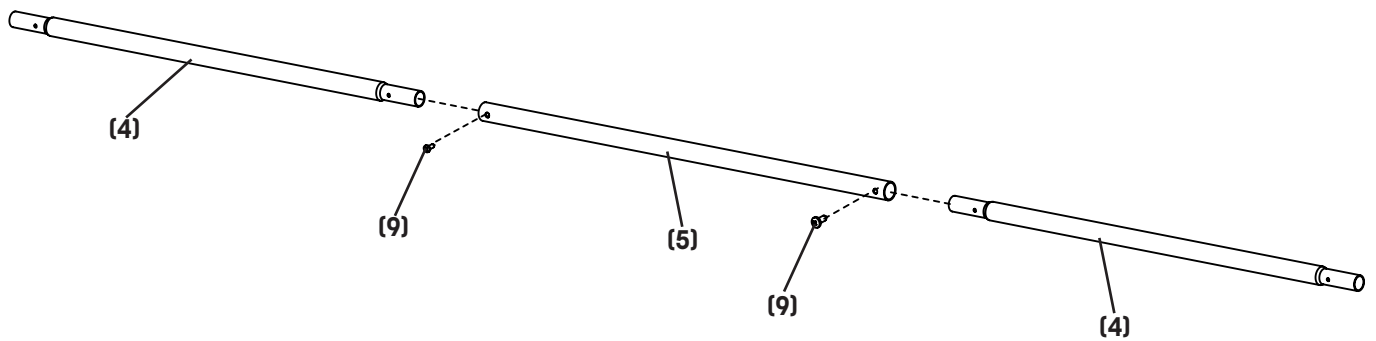

ASSEMBLY

STEP 7



6 Net (x1)

Insert the front tube (from step 5) into the side sleeve on net as shown.

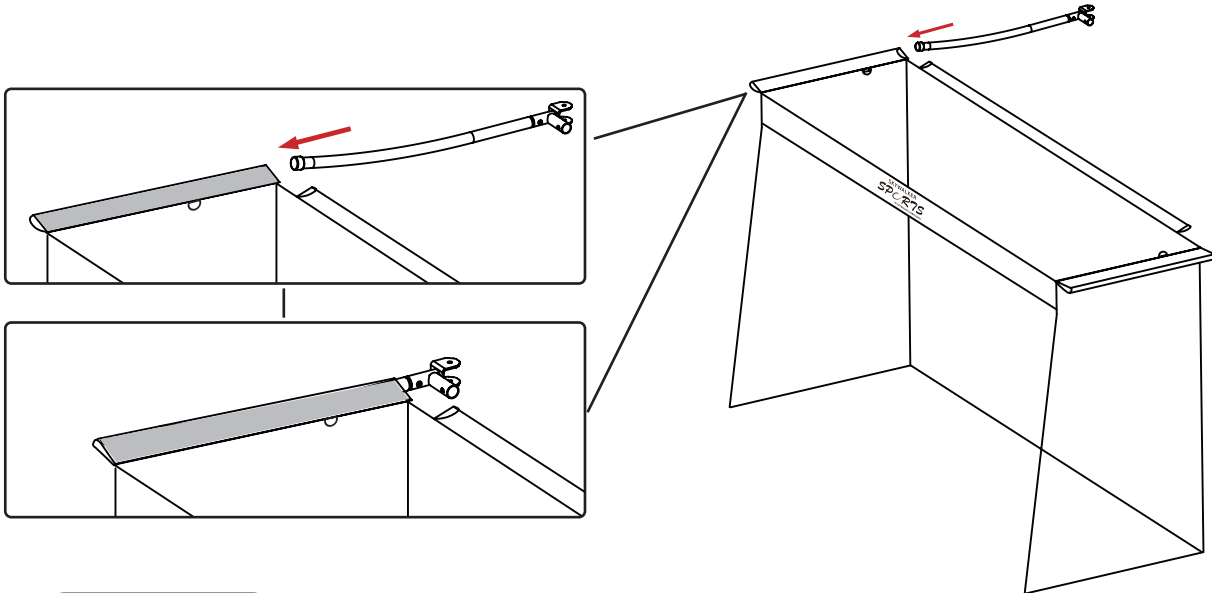

STEP 8

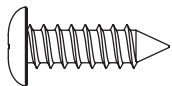

9 Screw (x1)

Insert the straight tube (from step 6) into the rear sleeve on net as shown, then secure the corner socket and straight tube with screw.

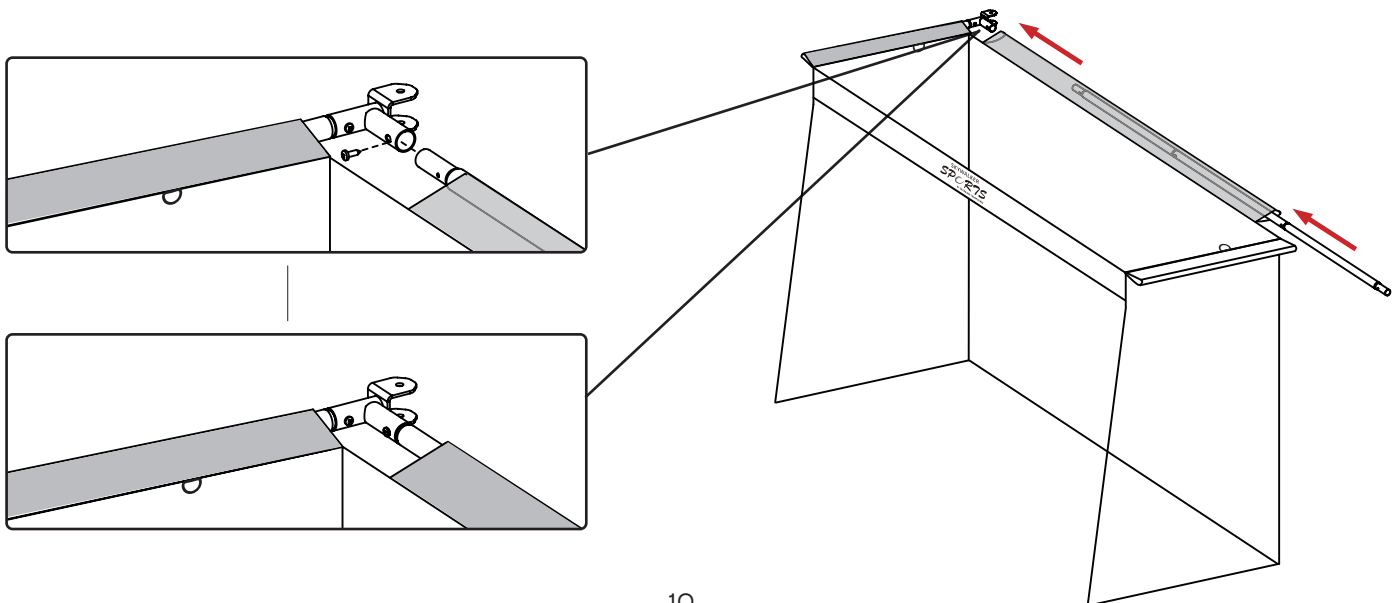

STEP 9

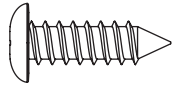
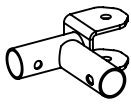

3 Corner socket (x1) **9** Screw (x1)

Place the remaining corner socket **(3)** onto opposite end and secure with screw **(9)**.

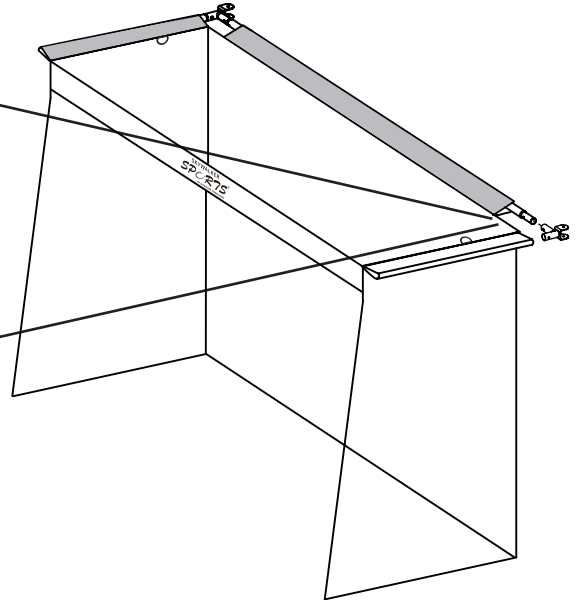
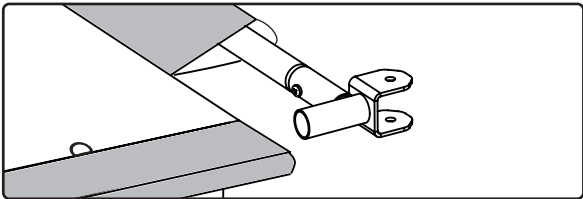
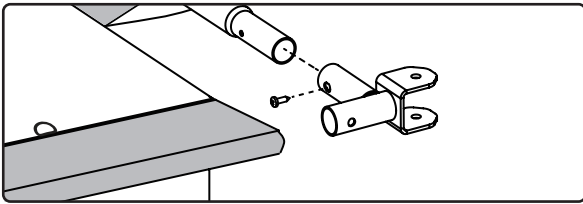

STEP 10

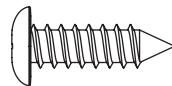

2 Front tube (x1) **9** Screw (x1)

Now insert the other front tube into remaining side sleeve on net as shown, then secure the corner socket **(3)** and front tube **(2)** with screw **(9)**.

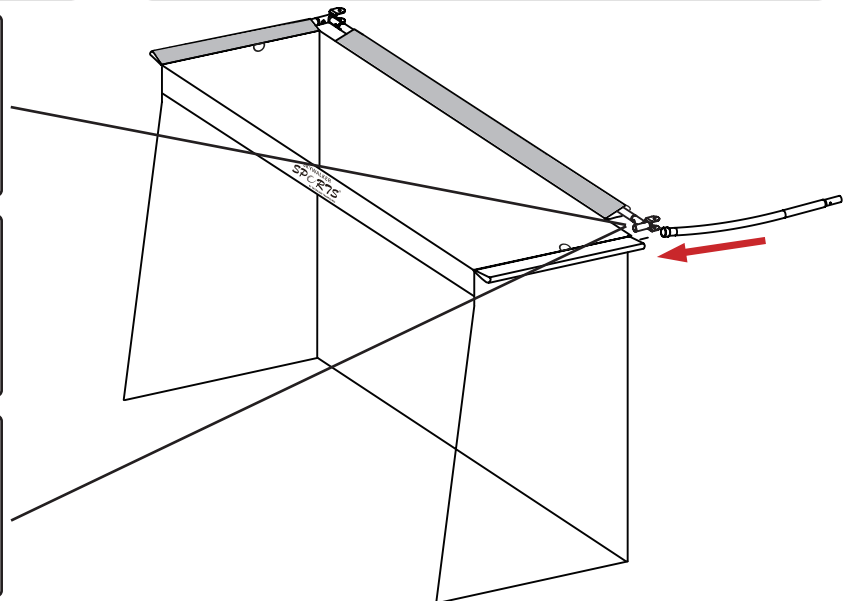
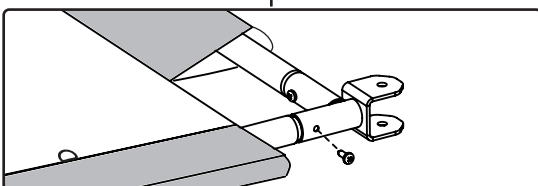
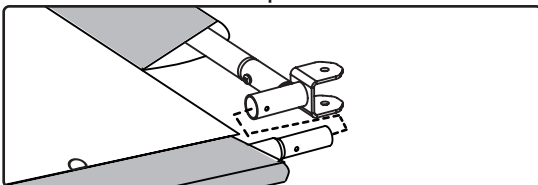
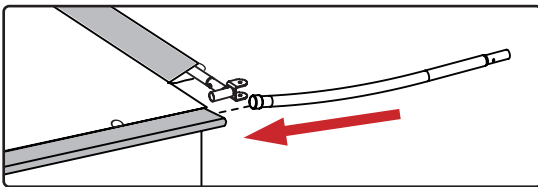

ASSEMBLY

STEP 11

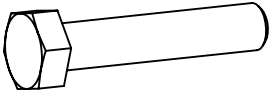

13 M8x50mm Bolt (x2)



14 M8 Washer (x4)



15 M8 Nut (x2)

Attach the assembled net to the connect tube (from steps 3 & 4) with M8x50mm Bolt (13), M8 Washers (14) and M8 Nut (15).

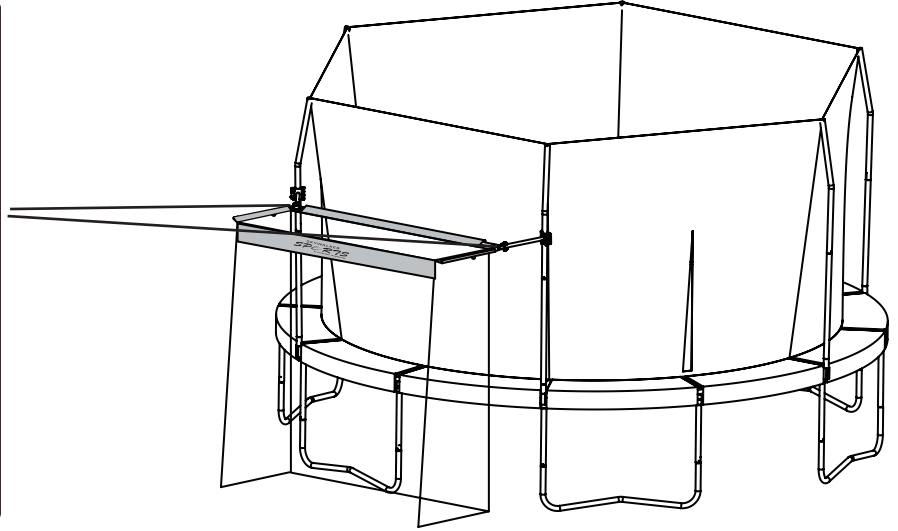
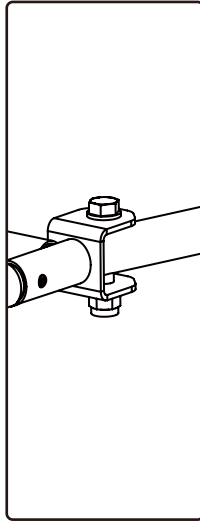
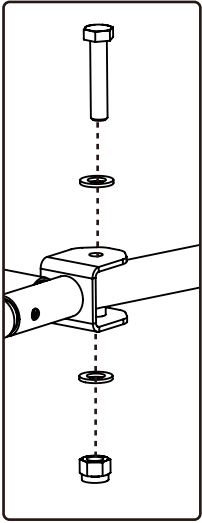

STEP 12

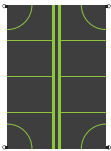

7 Target (x1)

Identify the Target (7), there are two sides. Choose whichever side will work best for you!

Side 1

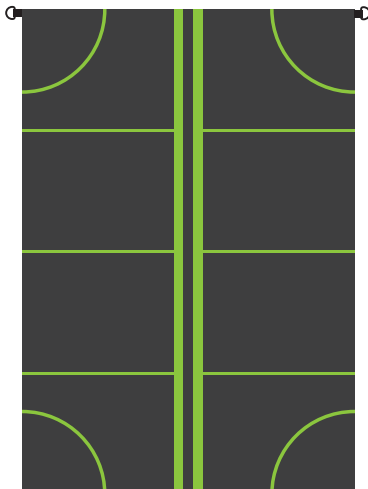

Side 2



STEP 13



8 Cinch with cord (x2)

Attach the Target (7) to Net (6) with the provided Cinch with cord (8) as shown.

Note: Press the ends of the cinch to open the hole and slide the cord through.

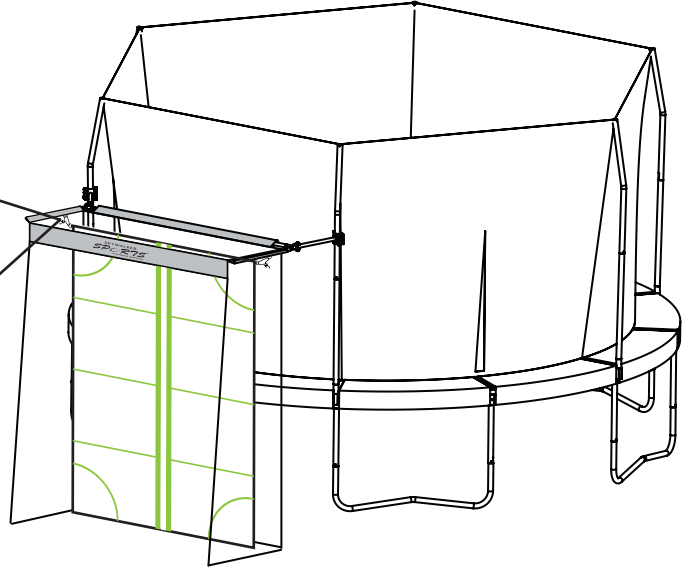
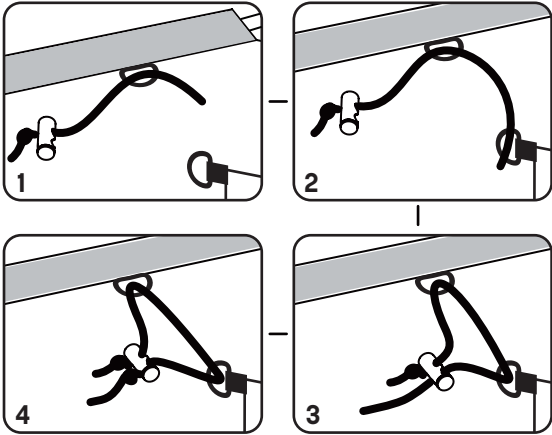

STEP 14

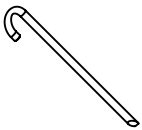

14 L stake (x6)

Straighten the net, then insert Stakes (14) into the ground to secure.

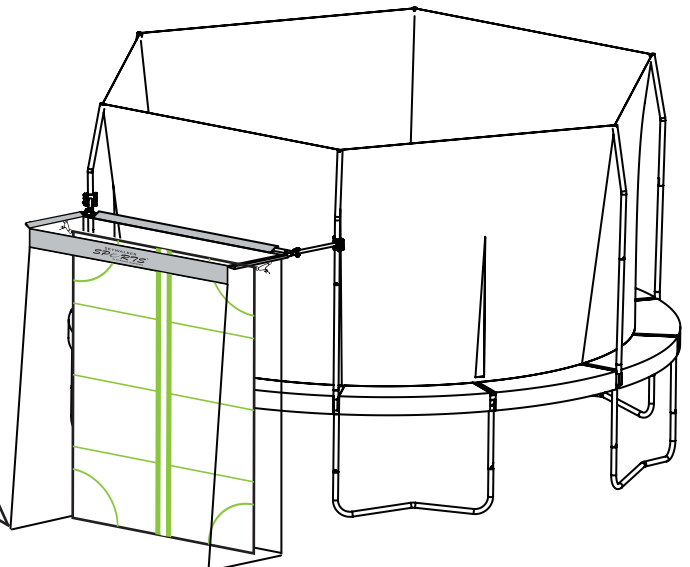
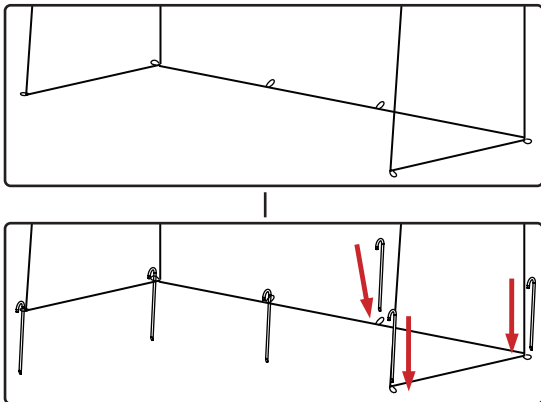

ASSEMBLY

STEP 15

That's it you're done! Congratulations, your sports net has been fully assembled. So here comes the real question, **are you satisfied with this completed product?** If you are, go ahead and **write a review** on the retailer's site you bought it from. We'd really appreciate it, and if we could, we'd give you a gold star. Are you completely frustrated and have some choice words for us? Contact us directly! We're not trying to ruin your life, we promise. And we'll do everything we can to make it right again. See contact info on page 2-3.

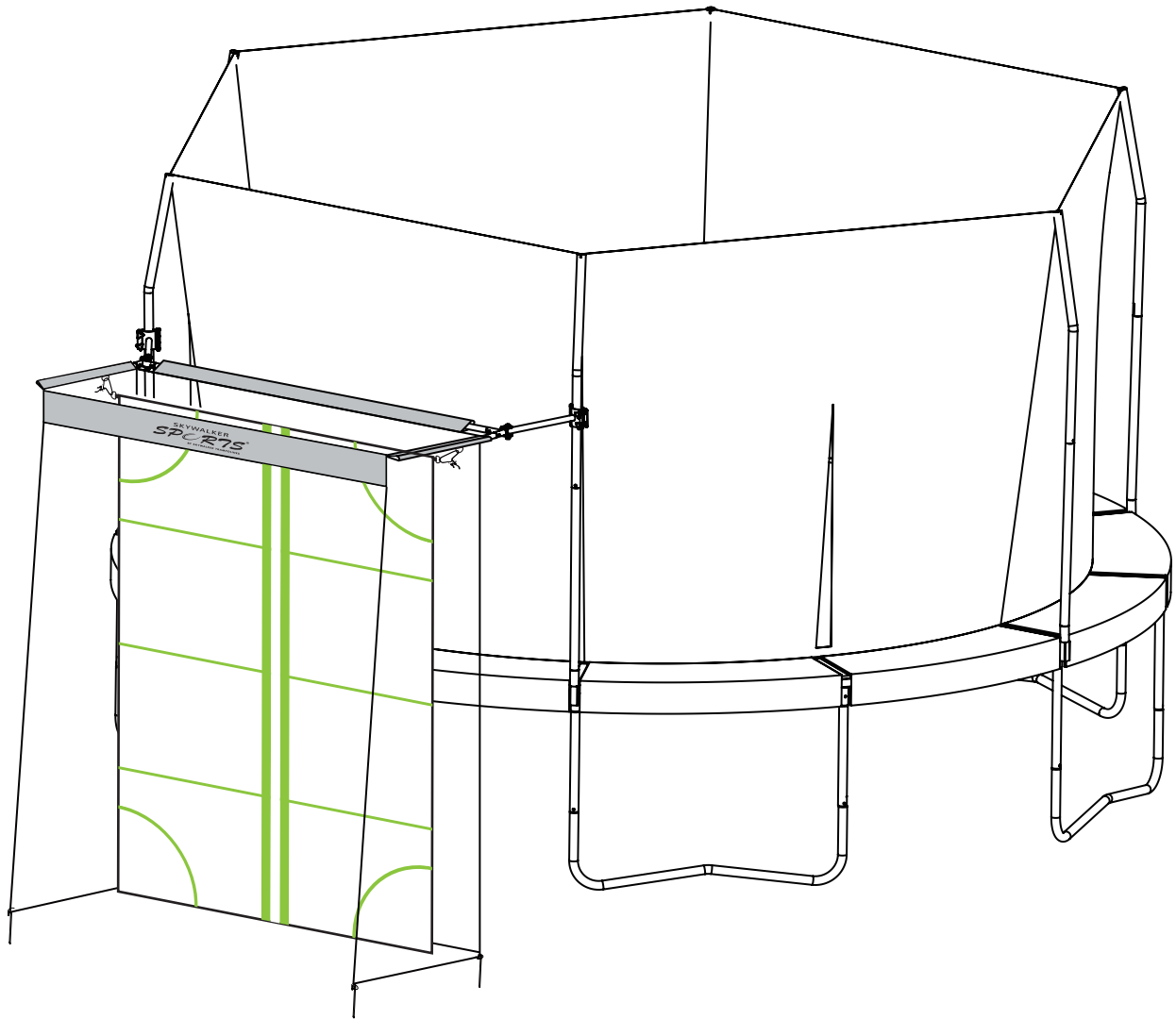

LIMITED WARRANTY

Skywalker Holdings, LLC warrants its products to be free from defects in material and workmanship under normal use and service conditions. **The steel frame is warranted for three (3) years after the date of purchase. All other parts are warranted for one (1) year after the date of purchase.** Warranty coverage extends only to the original retail purchaser from the date of original purchase. This warranty is only valid concerning products used for residential use. Products used for commercial use, such as schools and daycares, will not be covered.

WHAT IS NOT COVERED?



Weather Damage: The warranty does not cover damage due to the effects or acts of nature, such as earthquakes, wind, hurricanes, tornadoes, lightning, rain, fire, snow, excessive heat and cold conditions and/or sun damage. During the winter months the trampoline soft materials will need to be removed and stored in a dry place out of the snow. If left unprotected in the winter months, some components such as springs, jump mat, spring pad and enclosure, may become damaged, voiding this warranty.



Fading and Rust: Our products are fully galvanized. Skywalker does not warranty against rust or corrosion. Some areas may have higher air salt content, higher humidity, heavier rain and heavier snow. Skywalker does not warranty against fading. We suggest customers use a UV protectant on the frame pad to extend the life of the product.



Loss or damage to Product Due to: Loss or damage caused during shipping or caused by abuse, misuse, improper or abnormal usage or authorized repair are not covered by this warranty and may also void the warranty.



Unauthorized Replacement Parts: The warranty will become void if any defects or damages are associated with the use of unauthorized replacement parts. All replacement parts must be obtained from an authorized agent.



Assembly Service: The warranty does not cover acts or omissions provided by a third-party assembly service. It is the customer's responsibility to check all boxes and confirm all components are included and in their proper condition before installation occurs.

INSPECTION AND REPLACEMENT PARTS:

1. Your product SHOULD BE INSPECTED UPON UNPACKING AND SET UP AND THEREAFTER ON A REGULAR BASIS. WORN, DAMAGED OR BROKEN PARTS SHOULD BE REPLACED IMMEDIATELY AND BEFORE USE.
2. Call the Skywalker Trampoline Customer Service Department at 1-866-603-5867 to file a warranty claim. Be prepared to provide the following information: name, shipping address, a copy of your original sales receipt, a brief description of the problem and cause, trampoline model number and serial number. We may also ask for photos of the damaged/defective parts.
3. After reviewing your information and examining your photos, Skywalker Trampolines will make the determination if this part is covered by this warranty. If so, a replacement part will be sent to you.

NOTE: All requested information must be provided in order to review your warranty claim.

To order replacement parts for your product please visit www.skywalkertrampolines.com

Skywalker Holdings, LLC, PO Box 574, Brigham City, UT 84302 USA.

Printed in China © 2020 Skywalker Holdings, LLC

NOTE: SKYWALKER HOLDINGS, LLC IS NOT RESPONSIBLE OR LIABLE FOR INDIRECT, SPECIAL OR CONSEQUENTIAL DAMAGES ARISING OUT OF OR IN CONNECTION WITH THE USE OR PERFORMANCE OF THE PRODUCT OR OTHER DAMAGES WITH RESPECT TO ANY ECONOMIC LOSS, LOSS OF PROPERTY, LOSS OF REVENUE OR PROFITS, LOSS OF ENJOYMENT OR USE, COST OF REMOVAL, INSTALLATION OR OTHER CONSEQUENTIAL DAMAGES. SOME STATES DO NOT ALLOW THE EXCLUSION OR LIMITATION OF INCIDENTAL OR CONSEQUENTIAL DAMAGES. ACCORDINGLY, THE ABOVE LIMITATION MAY NOT APPLY TO YOU.

THE WARRANTY EXTENDED HEREUNDER IS IN LIEU OF ALL OTHER WARRANTIES AND ANY IMPLIED WARRANTY OF MERCHANTABILITY OR FITNESS FOR A PARTICULAR PURPOSE IS LIMITED IN ITS SCOPE AND DURATION TO THE TERMS SET FORTH HEREIN. SOME STATES OR COUNTRIES DO NOT ALLOW LIMITATIONS ON HOW LONG AN IMPLIED WARRANTY LASTS. ACCORDINGLY, THE ABOVE LIMITATION MAY NOT APPLY TO YOU. THIS WARRANTY GIVES YOU SPECIFIC LEGAL RIGHTS. YOU MAY ALSO HAVE OTHER RIGHTS WHICH VARY STATE TO STATE OR COUNTRY TO COUNTRY.

THIS WARRANTY IS VALID ONLY IN THE COUNTRY THE PRODUCT WAS PURCHASED.