

User Manual

Revision v1.4 January 2011



Breeze
All-in-one
Hardware System



Copyright 2011
All Rights Reserved
Manual Version 1.4
Part Number:

The information contained in this document is subject to change without notice. We make no warranty of any kind with regard to this material, including, but not limited to, the implied warranties of merchantability and fitness for a particular purpose. We shall not be liable for errors contained herein or for incidental or consequential damages in connection with the furnishing, performance, or use of this material.

This document contains proprietary information that is protected by copyright. All rights are reserved. No part of this document may be photocopied, reproduced or translated to another language without the prior written consent of the manufacturer.

TRADEMARK

Intel®, Pentium® and MMX are registered trademarks of Intel® Corporation. Microsoft® and Windows® are registered trademarks of Microsoft Corporation. Other trademarks mentioned herein are the property of their respective owners.

Safety

IMPORTANT SAFETY INSTRUCTIONS

1. To disconnect the machine from the electrical power supply, turn off the power switch and remove the power cord plug from the wall socket. The wall socket must be easily accessible and in close proximity to the machine.
2. Read these instructions carefully. Save these instructions for future reference.
3. Follow all warnings and instructions marked on the product.
4. Do not use this product near water.
5. Do not place this product on an unstable cart, stand, or table. The product may fall, causing serious damage to the product.
6. Slots and openings in the cabinet and the back or bottom are provided for ventilation to ensure reliable operation of the product and to protect it from overheating. These openings must not be blocked or covered. The openings should never be blocked by placing the product on a bed, sofa, rug, or other similar surface. This product should never be placed near or over a radiator or heat register or in a built-in installation unless proper ventilation is provided.
7. This product should be operated from the type of power indicated on the marking label. If you are not sure of the type of power available, consult your dealer or local power company.
8. Do not allow anything to rest on the power cord. Do not locate this product where persons will walk on the cord.
9. Never push objects of any kind into this product through cabinet slots as they may touch dangerous voltage points or short out parts that could result in a fire or electric shock. Never spill liquid of any kind on the product.

CE MARK



This device complies with the requirements of the EEC directive 2004/108/EC with regard to “Electromagnetic compatibility” and 2006/95/EC “Low Voltage Directive”.

FCC

This device complies with part 15 of the FCC rules. Operation is subject to the following two conditions:

- (1) This device may not cause harmful interference.
- (2) This device must accept any interference received, including interference that may cause undesired operation.

CAUTION ON LITHIUM BATTERIES

There is a danger of explosion if the battery is replaced incorrectly. Replace only with the same or equivalent type recommended by the manufacturer. Discard used batteries according to the manufacturer's instructions.



Battery Caution

Risk of explosion if battery is replaced by an incorrectly type.
Dispose of used battery according to the local disposal instructions.



Safety Caution

Note: To comply with IEC60950-1 Clause 2.5 (limited power sources, L.P.S) related legislation, peripherals shall be 4.7.3.2 "Materials for fire enclosure" compliant.

4.7.3.2 Materials for fire enclosures

For MOVABLE EQUIPMENT having a total mass not exceeding 18kg, the material of a FIRE ENCLOSURE, in the thinnest significant wall thickness used, shall be of V-1 CLASS MATERIAL or shall pass the test of Clause A.2.

For MOVABLE EQUIPMENT having a total mass exceeding 18kg and for all STATIONARY EQUIPMENT, the material of a FIRE ENCLOSURE, in the thinnest significant wall thickness used, shall be of 5VB CLASS MATERIAL or shall pass the test of Clause A.1

LEGISLATION AND WEEE SYMBOL

2002/96/EC Waste Electrical and Electronic Equipment Directive on the treatment, collection, recycling and disposal of electric and electronic devices and their components.

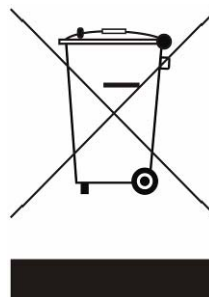

The crossed dustbin symbol on the device means that it should not be disposed of with other household wastes at the end of its working life. Instead, the device should be taken to the waste collection centers for activation of the treatment, collection, recycling and disposal procedure.

To prevent possible harm to the environment or human health from uncontrolled waste disposal, please separate this from other types of wastes and recycle it responsibly to promote the sustainable reuse of material resources.

Household users should contact either the retailer where they purchased this product, or their local government office, for details of where and how they can take this item for environmentally safe recycling.

Business users should contact their supplier and check the terms and conditions of the purchase contract.

This product should not be mixed with other commercial wastes for disposal.

Revision History

Changes to the original user manual are listed below:

Version	Date	Description
1.0	2008 July	<ul style="list-style-type: none">● Initial release
1.1	2009 February	<ul style="list-style-type: none">● B78 M/B Upgraded from v2.1 to 2.2● B98 V1.0 M/B information added● Second display installation added● 2nd FAN of B98 MB added● Drivers list and installation upgraded● Jumper setting upgraded● VGA version upgraded● Specification upgraded● 2-in-1 MSR + iButton / Fingerprint module installation added
1.2	2009 November	<ul style="list-style-type: none">● 17" TFT LCD added● Drivers installation removed● BIOS setup removed● B68 motherboard version added
1.3	2010 June	<ul style="list-style-type: none">● C48 motherboard version added● New system stand phased in● B68, B78 Jumper updated
1.4	2011 January	<ul style="list-style-type: none">● C48 motherboard updated to V2.1● B78 motherboard updated to V2.4● B98 motherboard updated to V1.1● 8.4" 2nd display phased in● SSD module added● OSD functions for 2nd display added

Table of Contents

1 Item Checklist	1
1-1 Standard Item	1
1-2 Optional Item	2
2 System View	3
2-1 Front View	3
2-2 Rear View with stand	4
2-3 Rear View without stand	4
2-4 Side View	5
2-5 Bottom View	5
2-6 I/O View	6
3 System Dimensions	7
3-1 15" System Dimensions	7
3-2 17" System Dimensions	7
4 Peripheral Installation	8
4-1 VFD Installation	8
4-2 Second Display Installation	9
4-3 Power Cord Installation	14
4-4 MSR / 2-in-1 MSR Installation	15
4-5 Cash Drawer Installation for B78 Motherboard	16
4-6 Cash Drawer Installation for B98/B68/C48 Motherboard	18
4-7 VESA Wall-Mount Kit Installation	20
4-8 Stand Assembly & Disassembly	21
5 System Assembly & Disassembly	23
5-1 HDD Replacement	23
5-2 Compact Flash Card Replacement	23
5-3 SSD Card Replacement	24
5-4 Power Adapter Replacement	24
6 Specification	25
6-1 B78 Motherboard	25
6-2 B98 / B68 / C48 Motherboard	27
7 Jumper Settings	29
7-1 B78 Motherboard	29
7-2 B98 Motherboard	36
7-3 B68 Motherboard	42
7-4 C48 Motherboard	48
7-5 C48 Jumper & BIOS/Utility Settings	51
Appendix A: Drivers Installation	58
Appendix B: OSD Functions for 2nd Display	59
Appendix C: VFD Customer Display	62

1 Item Checklist

Take the system unit out of the carton. Remove the unit from the carton by holding it by the foam inserts. The following contents should be found in the carton:

1-1 Standard Item

a.

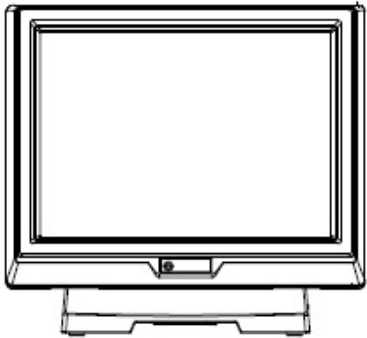

b.

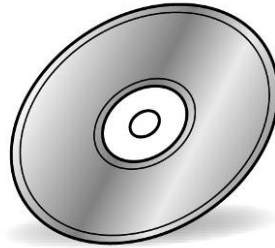

c.



d.

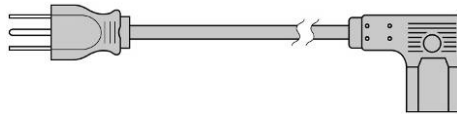

e.

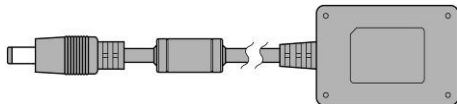

- a. System
- b. Driver CD
- c. RJ45-DB9 cable (x2)
- d. Power Cord
- e. Power adapter

1-2 Optional Item

The touch terminal device provides various peripheral options for your selection. Please refer to your local sales representative or distributor for further information.

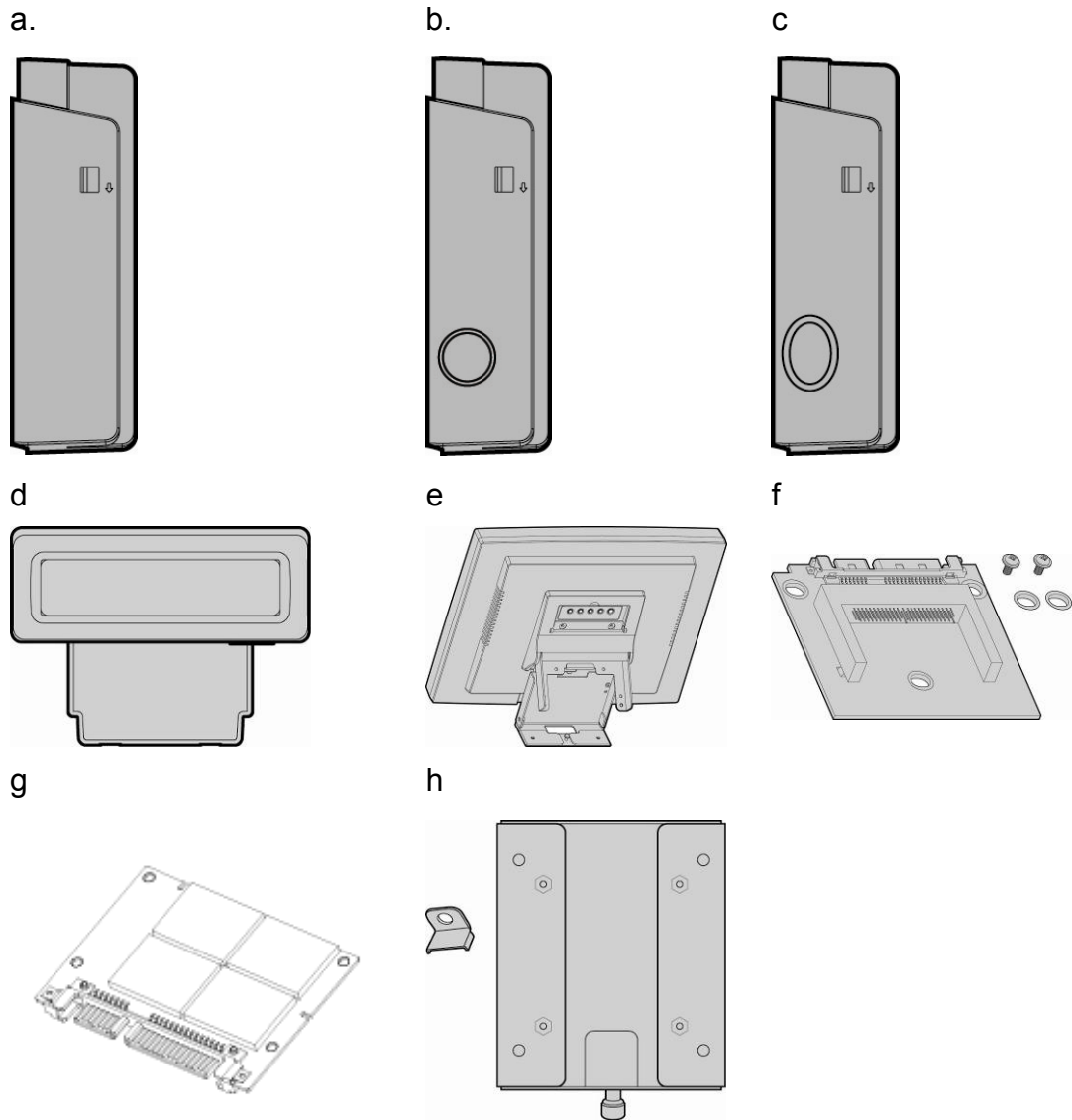

- a. MSR Module
- b. MSR + iButton Module
- c. MSR + Fingerprint Module
- d. VFD Customer Display (with RJ45 cable)
- e. Second Display with Touch
- f. CF Card Adapter Board
- g. SSD Module
- h. Wall Mount Kit

2 System View

2-1 Front View

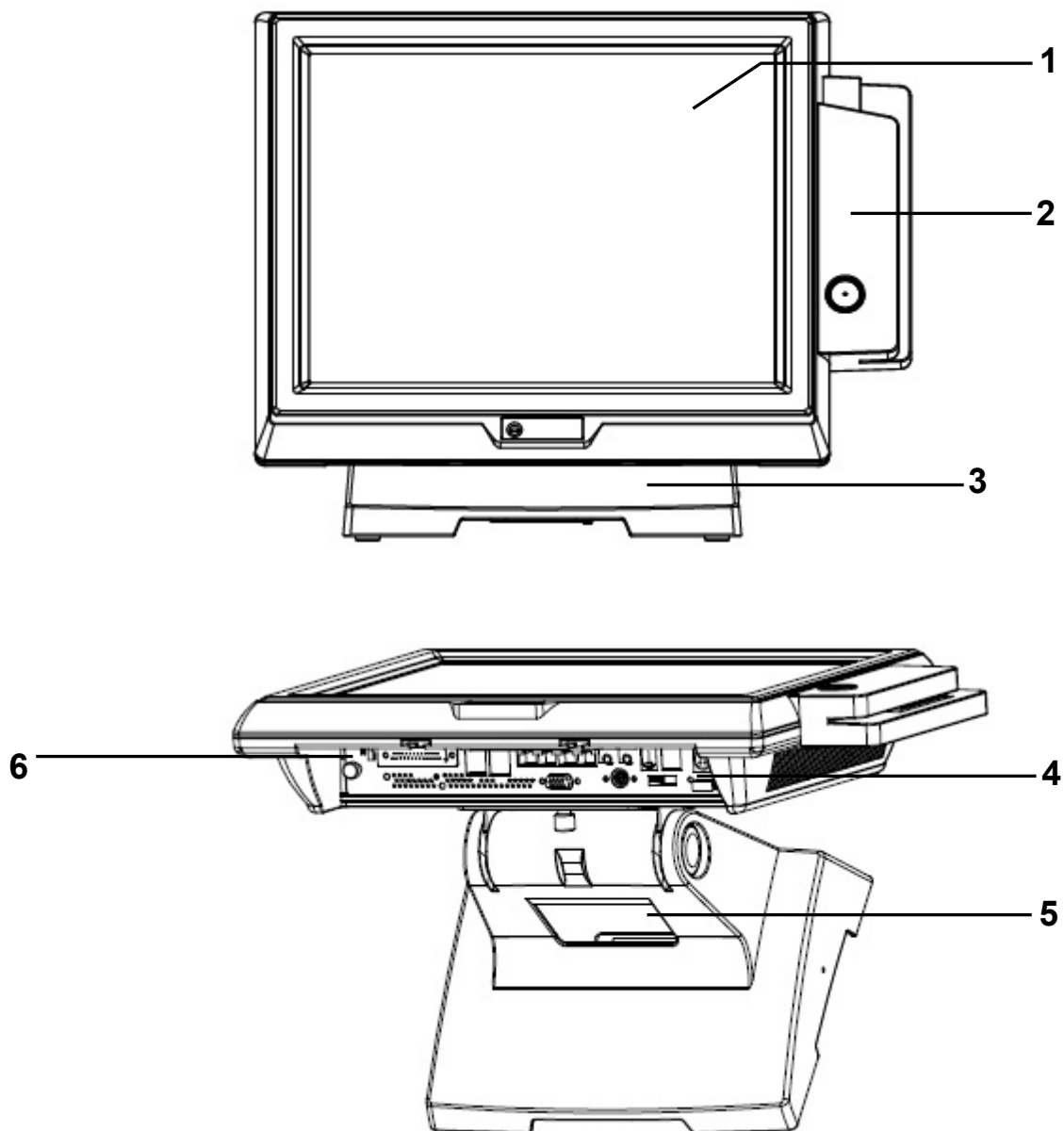

No.	Description
1	Touch
2	MSR (optional)
3	Stand (with power brick and cable management)
4	I/O Ports
5	Stand hole for cables outlet
6	Second Power Button

2-2 Rear View with stand



2-3 Rear View without stand

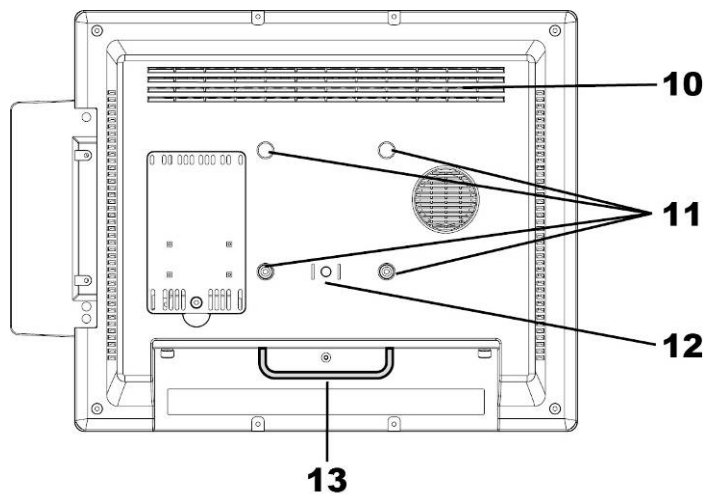

No.	Description
6	2 nd Display (Optional)
7	Ventilation holes
8	HDD Door
9	VFD dummy cover
10	Ventilation holes
11	VESA holes (100x100mm)
12	Thumbscrew hole for stand / wall-mount bracket
13	Handle of Motherboard

2-4 Side View



No.	Description
14	Speaker outlet
15	Stand hinge cover (at both sides)

2-5 Bottom View

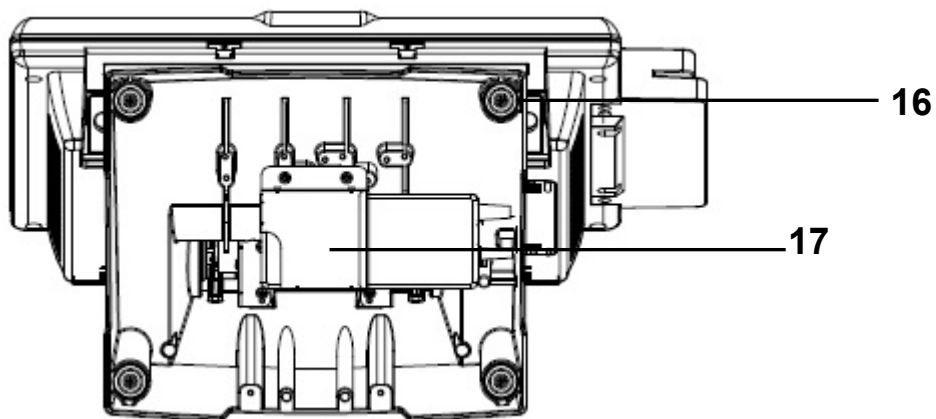

No.	Description
16	Rubber foot
17	Holder bracket for power brick

2-6 I/O View

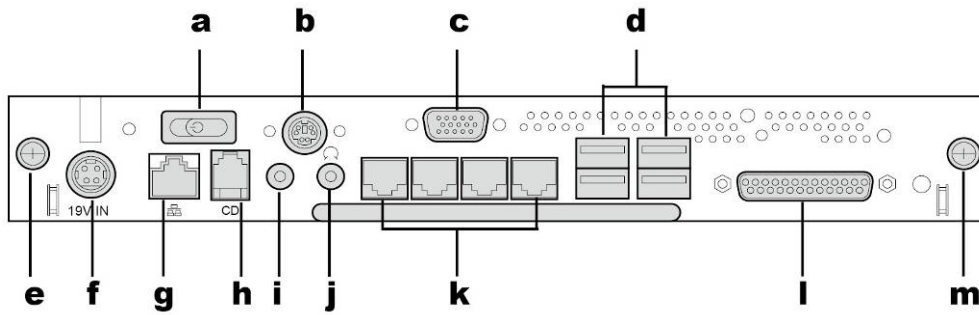

No.	Description
a	Power Switch
b	PS/2
c	2 nd VGA
d	USB (x4)
e / m	Thumbscrews for fixing the motherboard
f	DC-IN (19V)
g	LAN
h	Cash Drawer
i	MIC-in
J	Line-out
k	COM 1, 2, 3, 4
l	Parallel

3 System Dimensions

3-1 15" System Dimensions

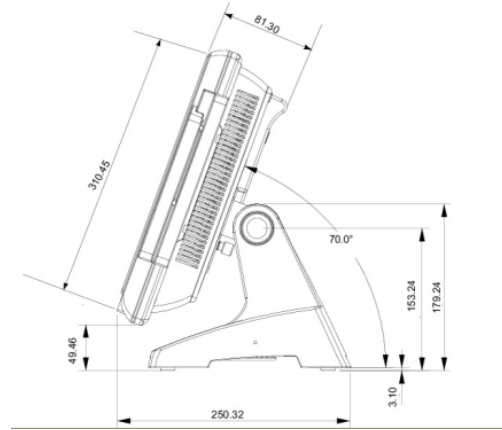
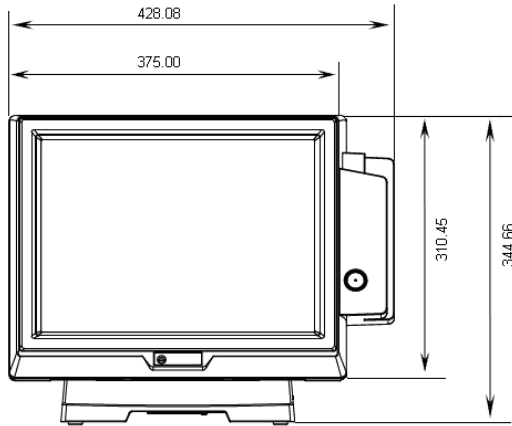

3-2 17" System Dimensions

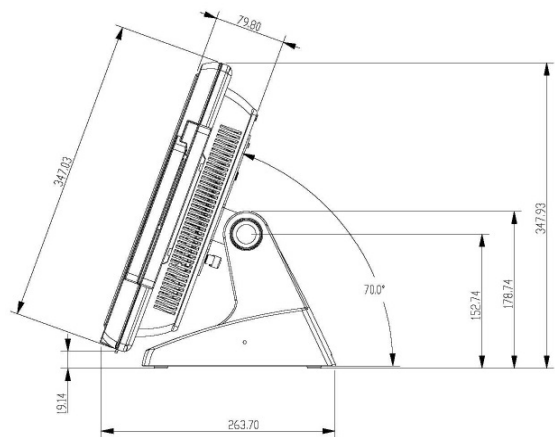
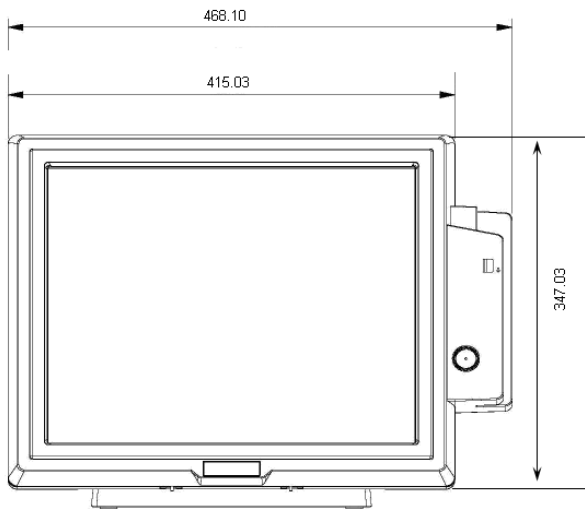

4 Peripheral Installation

4-1 VFD Installation

The VFD requires 12V power and must be connected to a powered COM port (COM3 or COM4). Please refer to chapter 7-1-3 (B78 motherboard, jumper JP3), chapter 7-2-3 (B98 motherboard, jumper JP5), Chapter 7- 3-3 (B68 motherboard, jumper JP3), and Chapter 7-4-3 (C48 motherboard, jumper JP7) for correct jumper setting.

■ VFD Module View



■ VFD Installation Procedure



1. Slide the VFD module to the VESA bracket on the stand and tighten it with thumb screw.
2. Connect the VFD cable to the COM port on the system.

4-2 Second Display Installation

4-2-1 8.4" Second Display Installation

■ Accessories:

System Stand



8.4" 2nd Display



- VGA Cable x 1
- Screw x 6
- 2nd Display Bracket



■ **Installation Procedure:**



1. Attach the 2nd display bracket to the stand system and fasten the thumb screw (x1).



2. Loosen the thumb screw (x2) and the screw (x2) of the female VGA cable.
3. Pull the I/O panel towards you by the handle

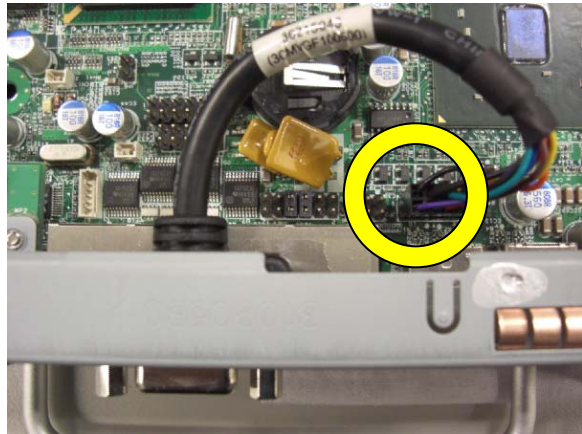

4. Replace the VGA cable to male type.
5. Connect the other end of VGA cable to the jumper on the motherboard.
The locations of VGA power jumper are as following:
B78: JP1 and JP2
B98: JP9 and JP13
B68: JP4
C48: JP18
Please see chapter 7 for different motherboards.

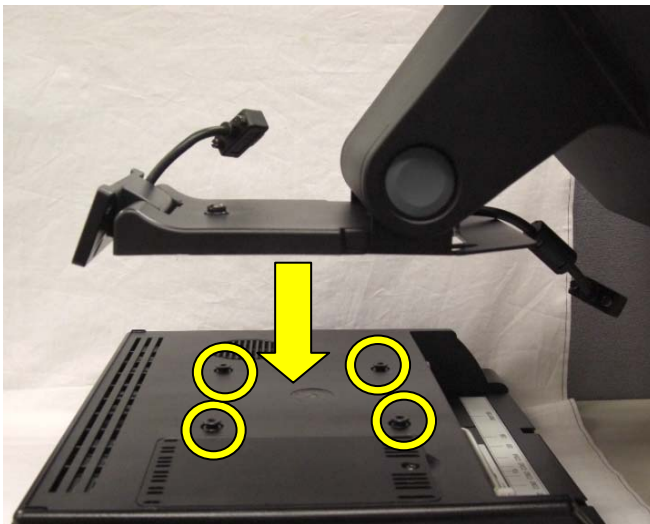

6. Attach the stand with 2nd display bracket to the LCD touch panel. Fix the stand with 2nd display bracket on the VESA holes (x4) until it snaps in place.
7. Fasten the thumb screw (x1) and connect the VGA cable to the LCD touch panel.



8. Attached the 2nd display and connect the other end of cable to the system port.

4-2-2 10.4" / 12.1" Second Display Installation

■ Accessories:

2nd display



VGA Cable x 1



Screw x 2



■ **Installation Procedure:**

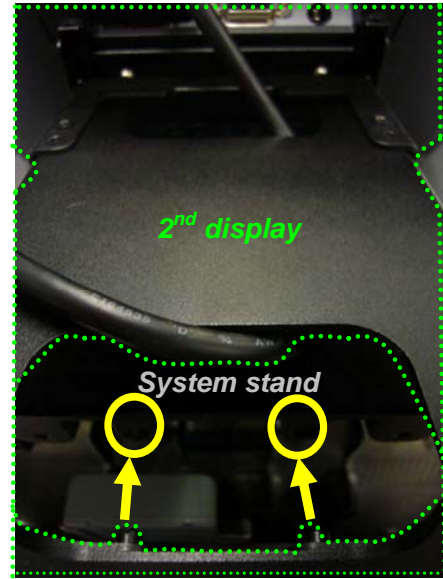

1. Thread two ends of the cable respectively through the upper and the lower gap on the 2nd display on the bracket.
2. Align the boss on 2nd display to the holes on the bottom of the system stand. Attach 2nd display to the stand.

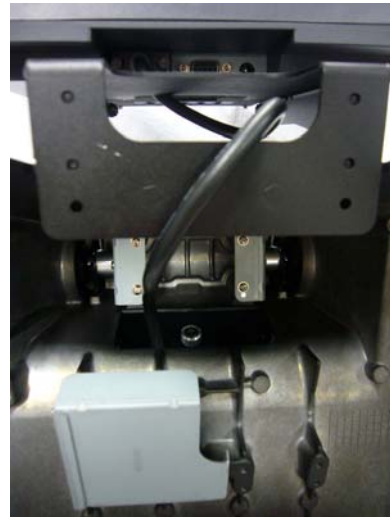
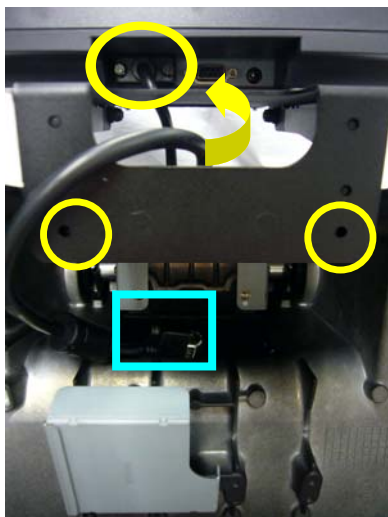

3. Fasten the 2nd display stand with the screws (x2), and connect cable to 2nd display.

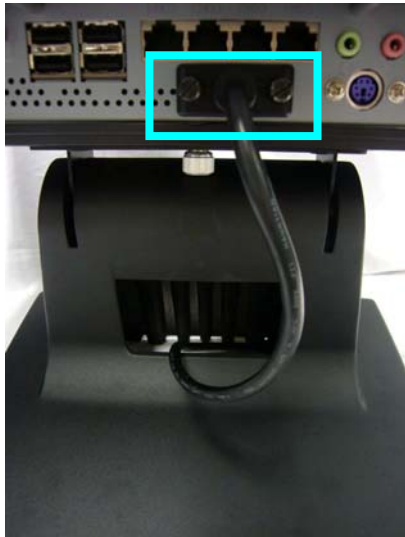

4. Route VGA cable through stand gap and connect the other end of the cable to the system port.

4-3 Power Cord Installation

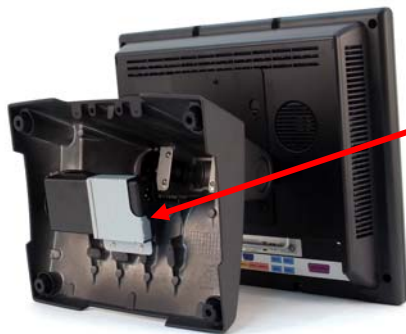

The Power brick is installed in the metal bracket fixed in the stand gap.



1. Connect the Power cord to the power adapter.
2. Route through the base gap for cable management.

4-4 MSR / 2-in-1 MSR Installation

There are 3 kinds of MSR and 2-in-1 MSR modules available at your request. You may request for further information in your local distributor or sales representative.

The 3 MSR modules are:

1. MSR Reader
2. MSR, 2-in-1 MSR with iButton Reader
3. 2-in-1 MSR with fingerprint reader.

The installing methods for the 3 kinds of MSR are similar to the instructions below.

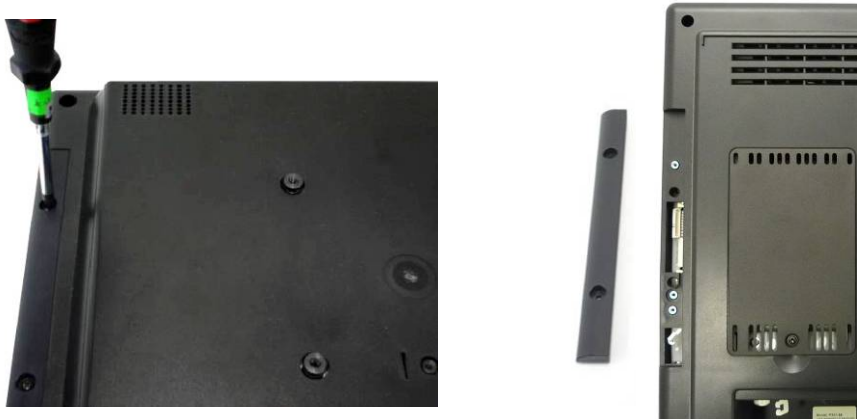

1. Loosen the screws (x2) on the MSR dummy cover.



2. Connect the respective connectors for each MSR or 2-in-1 MSR module.
3. Fasten the screws (x3) to fix the MSR or 2-in-1 MSR module.

4-5 Cash Drawer Installation for B78 Motherboard

You can install a cash drawer through the cash drawer port. Please verify the pin assignment before installation

Cash Drawer Pin Assignment

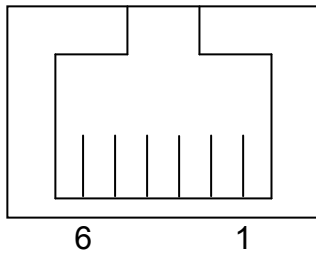

Pin	Signal
1	GND
2	DOUT bit0
3	DIN bit0
4	12V / 19V
5	DOUT bit1
6	GND

Cash Drawer Controller Register

The Cash Drawer Controller use one I/O addresses to control the Cash Drawer.

Register Location: 4B8h

Attribute: Read / Write

Size: 8bit

BIT	BIT7	BIT6	BIT5	BIT4	BIT3	BIT2	BIT1	BIT0
Attribute	Reserved			Read	Reserved	Write		Reserved

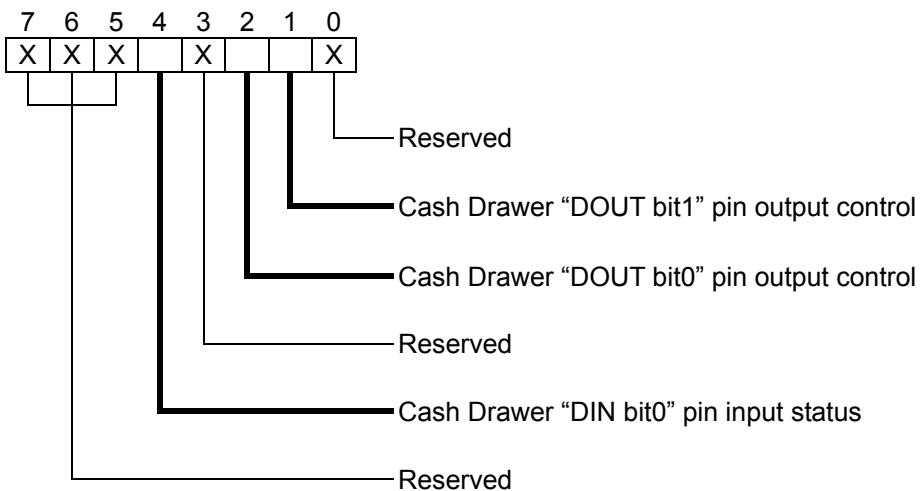

Bit 7: Reserved.

Bit 6: Reserved.

Bit 5: Reserved.

Bit 4: Cash Drawer "DIN bit0" pin input status.

= 1: the Cash Drawer closed or no Cash Drawer.

= 0: the Cash Drawer opened.

Bit 3: Reserved.

Bit 2: Cash Drawer "DOUT bit0" pin output control.

= 1: Opening the Cash Drawer

= 0: Allow closing the Cash Drawer

Bit 1: Cash Drawer "DOUT bit1" pin output control.

= 1: Opening the Cash Drawer

= 0: Allow closing the Cash Drawer

Bit 0: Reserved

Note: Please follow the Cash Drawer control signal design to control the Cash Drawer

Cash Drawer Control Command Example

Use Debug.EXE program under DOS or Windows98

Command	Cash Drawer
O 4B8 04	Opening
O 4B8 00	Allow to closing
<p>➤ Set the I/O address 4B8h bit2 =1 for opening the Cash Drawer by "DOUT bit0" pin control.</p> <p>➤ Set the I/O address 4B8h bit2 = 0 to allow closing Cash Drawer.</p>	

Command	Cash Drawer
I 4B8	Check status
<p>➤ The I/O address 4B8h bit4 =1 means the Cash Drawer is closed or no Cash Drawer.</p> <p>➤ The I/O address 4B8h bit4 =0 means the Cash Drawer is open.</p>	

4-6 Cash Drawer Installation for B98/B68/C48 Motherboard

You can install a cash drawer through the cash drawer port. Please verify the pin assignment before installation.

Cash Drawer Pin Assignment

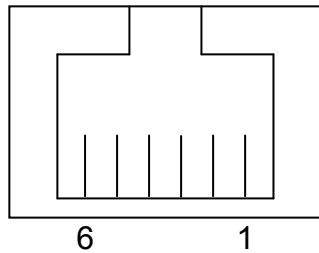

Pin	Signal
1	GND
2	DOUT bit0
3	DIN bit0
4	12V / 19V
5	DOUT bit1
6	GND

Cash Drawer Controller Register

The Cash Drawer Controller use one I/O addresses to control the Cash Drawer.

Register Location: 48Ch

Attribute: Read / Write

Size: 8bit

BIT	BIT7	BIT6	BIT5	BIT4	BIT3	BIT2	BIT1	BIT0
Attribute	Reserved		Read	Reserved	Write		Reserved	

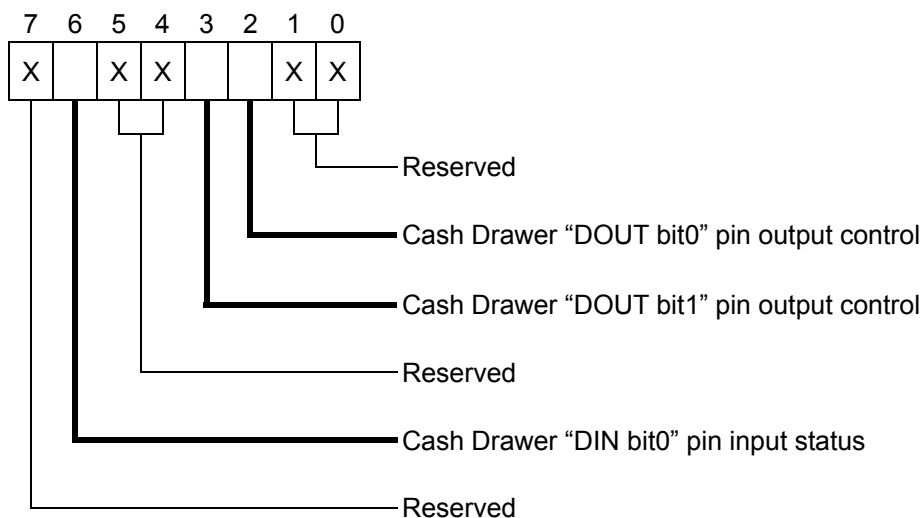

Bit 7: Reserved

Bit 6: Cash Drawer "DIN bit0" pin input status.

= 1: the Cash Drawer closed or no Cash Drawer

= 0: the Cash Drawer opened

Bit 5: Reserved

Bit 4: Reserved

Bit 3: Cash Drawer "DOOUT bit1" pin output control.

= 1: Opening the Cash Drawer

= 0: Allow close the Cash Drawer

Bit 2: Cash Drawer "DOOUT bit0" pin output control.

= 1: Opening the Cash Drawer

= 0: Allow close the Cash Drawer

Bit 1: Reserved

Bit 0: Reserved

Note: Please follow the Cash Drawer control signal design to control the Cash Drawer.

Cash Drawer Control Command Example

Use Debug.EXE program under DOS or Windows98

Command	Cash Drawer
O 48C 04	Opening
O 48C 00	Allow to close
<p>➤ Set the I/O address 48Ch bit2 =1 for opening Cash Drawer by "DOOUT bit0" pin control.</p> <p>➤ Set the I/O address 48Ch bit2 = 0 for allow close Cash Drawer.</p>	

Command	Cash Drawer
I 48C	Check status
<p>➤ The I/O address 48Ch bit6 =1 mean the Cash Drawer is opened or not exist.</p> <p>➤ The I/O address 48Ch bit6 =0 mean the Cash Drawer is closed.</p>	

4-7 VESA Wall-Mount Kit Installation

If you want to mount the POS terminal on the wall, please order the wall mount kit from you distributor and follow the steps below for the installation.

■ Wall-mount kit accessory:



■ Installation procedure:



1. Remove the stand by loosening the thumb screw (x1).
2. Place the wall mount bracket on the rear cover and tighten the screw (x1).

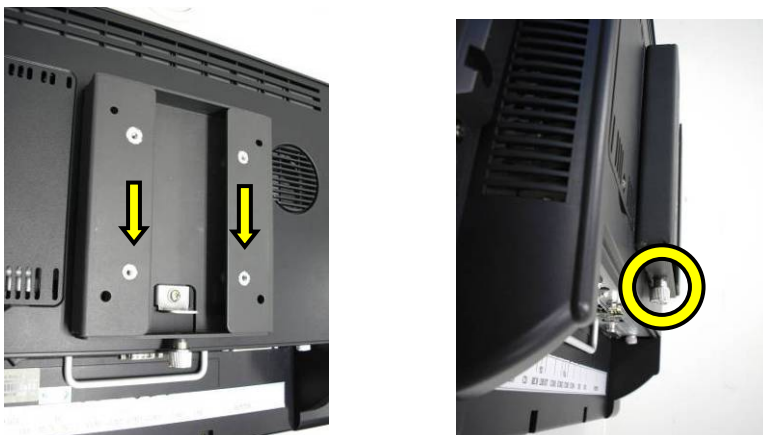

3. Attach the wall mount bracket and tighten with thumbscrew (x1)

4-8 Stand Assembly & Disassembly

Stand Assembly

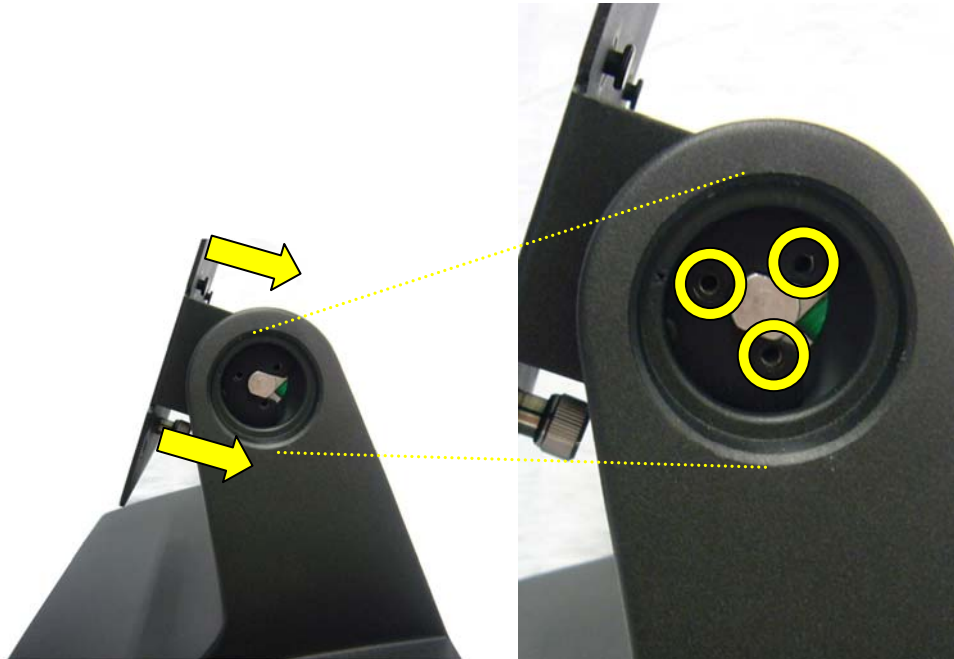

1. Slide the VESA hinge bracket into the metal hinge shaft on the stand.
2. Fasten the screws (x6) (3 on both sides) to fix the VESA hinge bracket onto the stand.



3. Use rubber hinge cover to plug the holes on both sides.

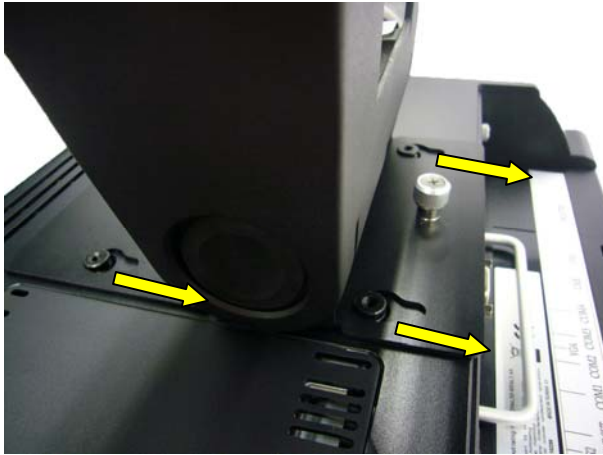

4. Align larger end of the teardrop mounting holes on the VESA hinge bracket with fixing screws (x4) on the rear cover of the system. Slide to narrow end of the mounting holes, and stick the bracket to the system.
5. Push and fasten the thumb screw to fix it to the system.

Stand Disassembly



1. Loosen the thumb screw.
2. Slide the system upward to separate from the stand.

5 System Assembly & Disassembly

5-1 HDD Replacement

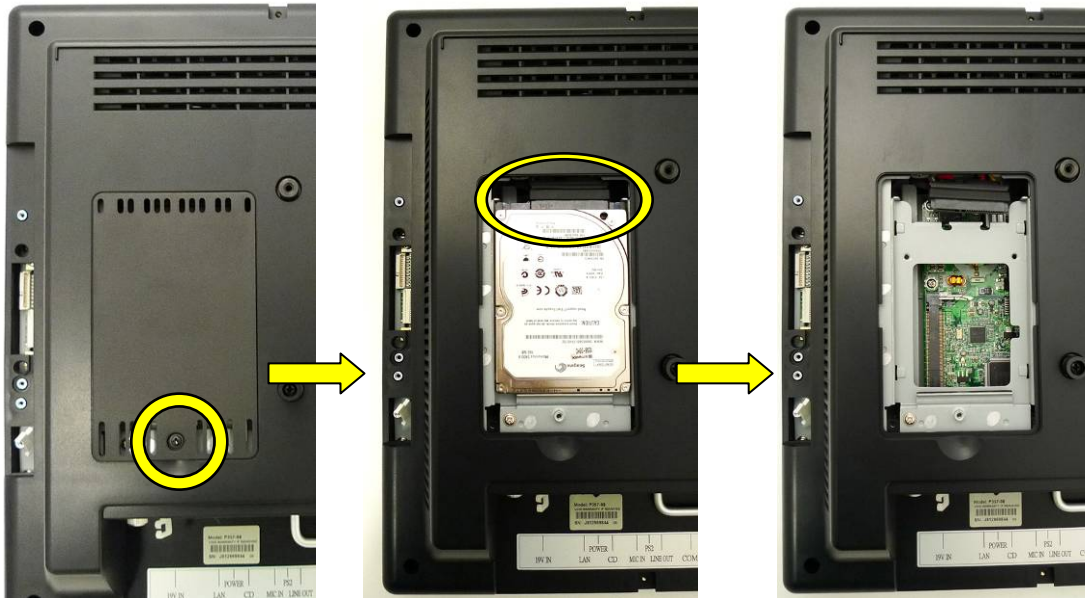

1. Remove the screw (x1) to open the HDD door.
2. Disconnect the HDD cable (x1).
3. Replace the HDD.

5-2 Compact Flash Card Replacement

If the system is equipped with CF (Compact Flash) slot as storage device, please follow the following steps to replace CF card.

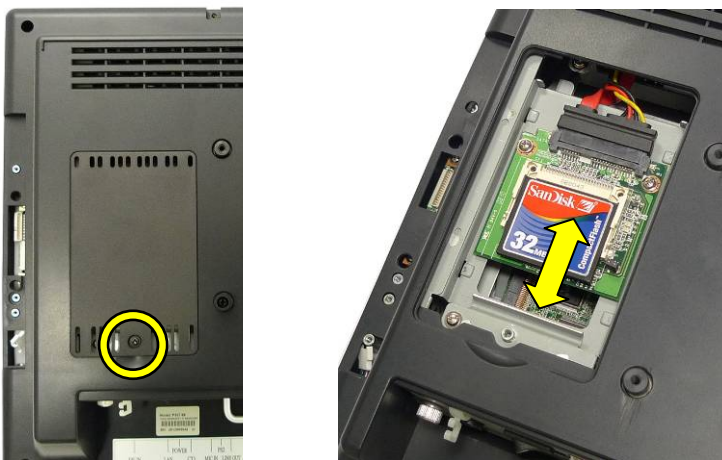

1. Loosen the screw (x1) to open the HDD door, and replace the CF card.

5-3 SSD Card Replacement

If the system is equipped with SSD card as storage device, please follow the following steps to replace SSD card.

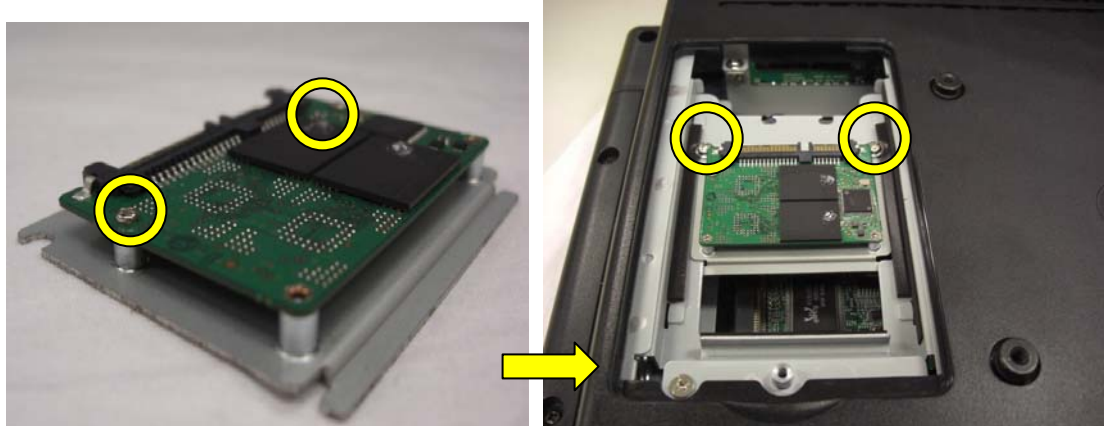

1. Loosen the screw (x1) to open the HDD door.(see 5-1 step1)
2. Fasten the screw (x2) to fix the SSD card on the SSD holder bracket.
3. Fit the SSD holder bracket into the slot and fasten the screw (x2).

5-4 Power Adapter Replacement



1. Route the adapter cable from the hole of cable management of the stand.



2. Disconnect the power cord from the adapter.
3. Loosen the screws (x2) to disassemble the power adapter holding bracket and the adapter.

6 Specification

6-1 B78 Motherboard

Motherboard	B78	
Model/System	15" System	17" System
CPU	Fanless: Intel Celeron M ULV 1.0GHz (BGA) With cooler: Intel Celeron M 1.5GHz / Pentium M 1.8GHz	Fanless: Intel Celeron M ULV 1.0GHz (BGA) Fan: Intel Celeron M 1.5GHz
Chipset	Intel 852GM + ICH4 FSB 400MHz	
System Memory	2 x DDR SO-DIMM Slot support up to 2GB	
Graphic Memory	Shared system memory up to 64MB	
LCD Touch Panel		
LCD Size	15" TFT LCD	17" TFT LCD
Brightness	250nits	250-400nits
Maximal Resolution	1024 x 768	1280 x 1024
Touch Screen Type	Resistive	Resistive/SAW
Tilt Angle	0° ~ 70°	0° ~ 70°
Storage		
HDD	one 2.5" SATA HDD bay	
Flash Memory	by optional SSD without HDD	
Expansion		
Mini-PCI Slot	1	
External I/O Ports		
USB	4 ports (V2.0)	
PS/2	1	
Serial / COM	4 x COM ports RJ-45 connectors (COM1 & COM2 standard RS-232; COM3 & COM4 pin9 with 5V /12V power by jumper)	
Parallel	1	
LAN (10 /100 / 1000)	1 x RJ45	
DC Jack	1	
2nd VGA	1	
Audio Jack	1 x Line-out, 1 x MIC-in	
Audio		
Built in Speaker	2 x 2W speakers	
Power		
Power Adapter	19V/90W	

Control / Indicator	
Power Button	2
Indicator LED	1
Peripheral	
MSR	3 Tracks MSR (PS/2 , USB)
2-in-1 MSR	MSR (PS/2, USB) / Fingerprint (USB) MSR (PS/2, USB) / iButton (PS/2)
Second Display	8.4" / 10.4" / 12.1" 2nd display (optional touch)
Customer Display	Flush mount VFD display 2 x 20 characters (COM)
Communication	
Wireless LAN	802.11 b/g/n wireless LAN card & antenna
Environment	
EMC & Safety	FCC, Class A, CE, LVD
Operating Temperature	5°C ~ 35°C (41°F ~ 95°F)
Storage Temperature	-20°C ~ 55°C (-4°F ~ 140°F)
Operating Humidity	20% ~ 80% RH non condensing
Storage Humidity	20% ~ 85% RH non condensing
Dust & Water Proof	IP 54 (Front bezel)
Dimension	
(W x D x H)	15" LCD 70 degree : 250 x 250.99 x 347 mm 17" LCD 70 degree : 415 x 264 x 348 mm
Weight (N.W./G.W.)	
	15" : 8.1kgs / 9.1kgs 17" : 9.1kgs / 10.1kgs
Mounting	
	100mm x100mm VESA Standard holes
OS Support	
	Windows XP Professional, Window 7, Windows Embedded POSReady 2009, Windows XP Embedded, Windows XP Professional for Embedded, Linux

* This specification is subject to change without prior notice.

6-2 B98 / B68 / C48 Motherboard

Motherboard	B68	B98	C48
CPU Supports	Intel Atom N270 processors 1.6G (BGA)	Intel Celeron M 1.86G/ Core duo 2.0G/ Core 2 duo 1.66G (socket)	Intel Pineview D525 dual core 1.8G (BGA)
Chipset	Intel 945GSE + ICH7M, FSB 533MHz	Intel 945GME + ICH7M, FSB 533 / 667MHz	CPU with Graphic built-in + ICH 8M, FSB 800MHz
System Memory	2 x DDR2 DIMM up to 2GB, FSB 533 MHz	2 x DDR2 DIMM up to 4GB, FSB 533 / 667MHz	2 x DDR3 DIMM up to 4GB, FSB 800MHz
Graphic Memory	Share system memory up to 224MB		Intel GMA 3150, share system memory up to 256MB
LCD Panel			
LCD Size	15" / 17"		15"
Brightness (cd/m ²)	15" 250nits 17" 300nits		250nits
Maximal Resolution	15" 1024 x 768 17" 1280 x 1024		1024 x 768
Touch Screen Type	15" Resistive 17" Resistive / SAW		Resistive
Tilt Angle (Degree)	15" 0~70° 17" 0~ 70°		0~70°
Storage			
HDD	one slim HDD bay support SATA HDD		
Flash Memory	by optional compact SSD (without HDD)		
Expansion			
Mini-PCI Socket	N/A	1	N/A
Mini-PCI-E Slot	1	N/A	1
External I/O Ports			
USB	4 ports (V2.0)		
PS/2	1		
Serial / COM	4 x RJ-45 COM connector (COM1 & COM2 standard RS-232; COM3 & COM4 pin10 with 5V /12V power by jumper)		4 x RJ-45 COM connector (COM1/COM2 standard RS-232 without power, COM3 /COM4 powered COM with power enable /disable by BIOS setting and +5V/+12V by MB setting. COM3 default +5V/ COM4 default +12V)
Parallel	1		

Motherboard	B68	B98	C48
LAN (10 /100 / 1000)	1 x RJ-45		
DC Jack	1		
2nd VGA	1 (Female)		
Cash Drawer Port	1 x RJ-11 (for +24V Cash Drawer)		
Audio Jack	1 x Line-out, 1 x MIC-in		
Audio			
Built in Speaker	15": 2 x 2W speakers 17": 2 x 3W speakers		2 x 2W speakers
Power			
Power Adapter	19V/90W		
Control / Indicator			
Power Button	2		
Indicator LED	1		
Peripheral			
MSR	3 Tracks MSR (PS/2, USB)		
2-in-1 MSR	MSR (PS/2, USB) + Fingerprint (USB) / MSR (PS/2, USB) + iButton (PS/2)		
Second Display	8.4" / 10.4" / 12.1" / 15" 2nd display (optional touch)		
Customer Display	Flush mount VFD display 2 x 20 characters (COM)		
Communication			
Wireless LAN	802.11 b/g/n wireless LAN card & antenna		
Environment			
EMC & Safety	FCC, Class A, CE, LVD		
Operating Temperature	5°C ~ 35°C (41°F~ 95°F)		
Storage Temperature	-20°C ~ 55°C (-4°F ~ 140°F)		
Operating Humidity	20% ~ 80% RH non condensing		
Storage Humidity	20% ~ 85% RH non condensing		
Dust & Water Proof	IP 54 (Front bezel)		
Dimension(W x D x H)	15": 8.1kgs / 9.1kgs 17" : 9.1kgs / 10.1kgs		15": 8.1kgs / 9.1kgs
Mounting	100mm x100mm VESA Standard holes		
OS Support	Windows XP Professional, Windows Embedded POSReady 2009, Windows XP Embedded, Windows XP Professional for Embedded, Windows 7, Linux		

* This specification is subject to change without prior notice.

7 Jumper Settings

This chapter describes the connector with function description and jumper settings for motherboard B78 v2.4, B98 v1.1, B68 v1.0 and C48 v2.1.

7-1 B78 Motherboard

7-1-1 B78 Motherboard Layout

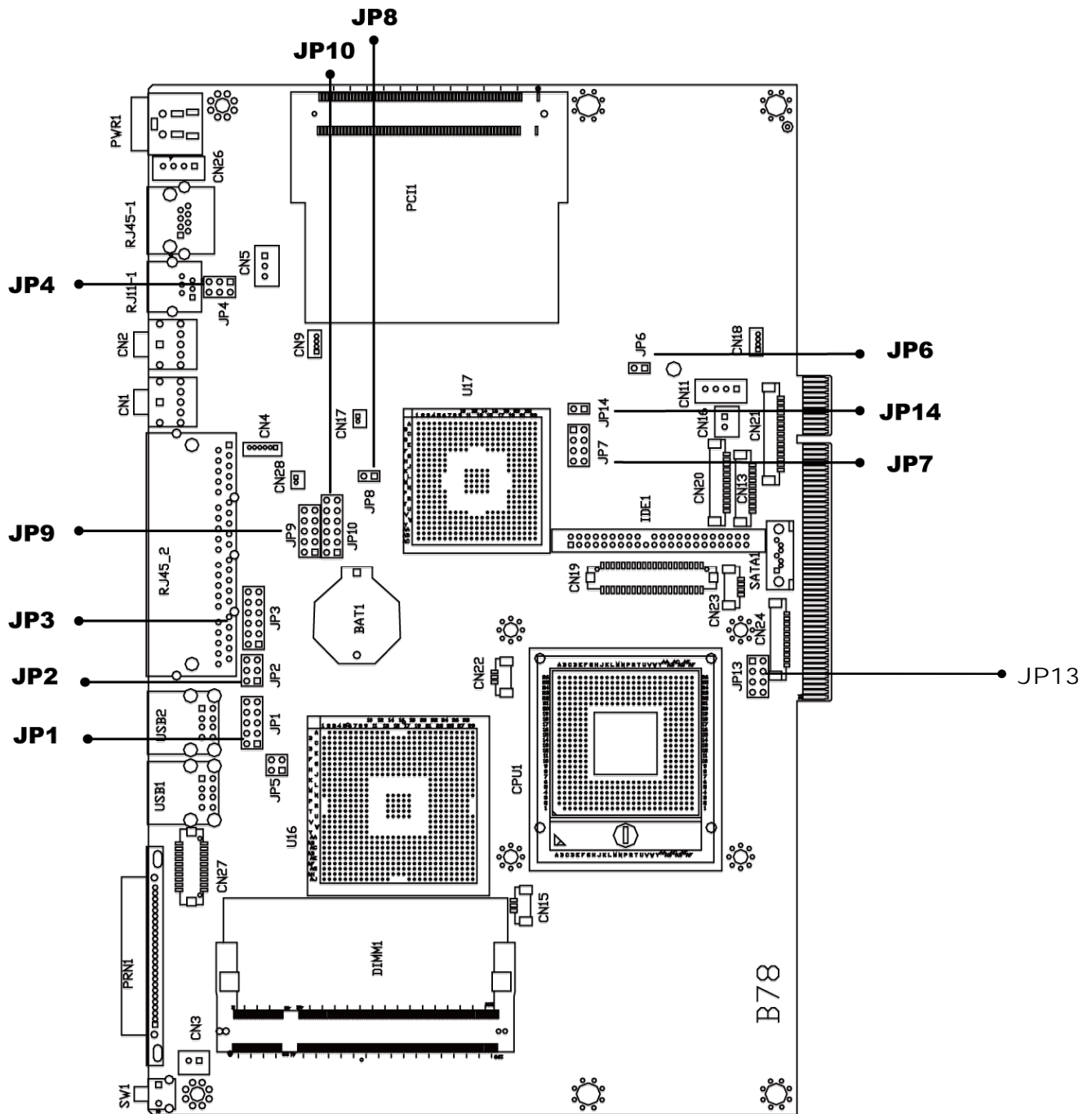

7-1-2 B78 Connector and function

Connector	Function
BAT1	CMOS Battery Base (Use CR2023)
CN1	Audio Line Out
CN2	Audio MIC In
CN3	Internal Power Switch
CN4	Speaker & MIC Connector
CN9	CD-IN Connect
CN11	Power Connector For 3.5" HDD
CN13	COM5 for Touch
CN15	CPU FAN Connector
CN16	Hardware Reset
CN18	USB2
CN19	LCD Interface Connector
CN20	Inverter Connector
CN21	Card Reader Connector
CN22	System FAN Connector
CN23	IrDA Connector
CN26	Internal Power In Connector
CN27	Internal LPT Connector
IED1	Secondary IDE Connector (Pitch = 2.0mm)
PRN1	Parallel Port
PWR1	+19V Power Adaptor
RJ11_1	Cash Drawer Connector
RJ45_1	LAN (On Board)
RJ45_2	COM1, COM2, COM3, COM4
SATA1	SATA Connector
USB1	USB3, USB4
USB2	USB5, USB6
JP1	VGA Port
JP2	VGA Power
JP3	COM3/COM4 Power Setting
JP4	Cash Drawer Power Setting
JP6	Power Mode Setting
JP7	LCD ID Setting
JP8	CMOS Operation Mode
JP9 / 10	COM2 RS232/485/422 Setting
JP13	System Indicator
JP14	USB Path Setting

7-1-3 B78 Jumper settings

1. COM2 RS232/485/422 Setting

Function	JP10	JP9																																																				
	(1-2) (3-4) (5-6) (7-8) (9-10) (11-12)	(1-2) (3-4) (4-6) (5-7) (7-8) (9-10)																																																				
▲RS232	<table style="border-collapse: collapse; margin: auto;"> <tr><td></td><td>1</td><td>3</td><td>5</td><td>7</td><td>9</td><td>11</td></tr> <tr><td>■</td><td>□</td><td>□</td><td>□</td><td>□</td><td>□</td><td>□</td></tr> <tr><td>■</td><td>□</td><td>□</td><td>□</td><td>□</td><td>□</td><td>□</td></tr> <tr><td></td><td>2</td><td>4</td><td>6</td><td>8</td><td>10</td><td>12</td></tr> </table>		1	3	5	7	9	11	■	□	□	□	□	□	□	■	□	□	□	□	□	□		2	4	6	8	10	12	<table style="border-collapse: collapse; margin: auto;"> <tr><td></td><td>1</td><td>3</td><td>5</td><td>7</td><td>9</td></tr> <tr><td>■</td><td>■</td><td>■</td><td>■</td><td>□</td><td>□</td></tr> <tr><td>■</td><td>■</td><td>□</td><td>□</td><td>□</td><td>□</td></tr> <tr><td></td><td>2</td><td>4</td><td>6</td><td>8</td><td>10</td></tr> </table>		1	3	5	7	9	■	■	■	■	□	□	■	■	□	□	□	□		2	4	6	8	10
	1	3	5	7	9	11																																																
■	□	□	□	□	□	□																																																
■	□	□	□	□	□	□																																																
	2	4	6	8	10	12																																																
	1	3	5	7	9																																																	
■	■	■	■	□	□																																																	
■	■	□	□	□	□																																																	
	2	4	6	8	10																																																	
RS485	<table style="border-collapse: collapse; margin: auto;"> <tr><td></td><td>1</td><td>3</td><td>5</td><td>7</td><td>9</td><td>11</td></tr> <tr><td>□</td><td>■</td><td>□</td><td>□</td><td>□</td><td>□</td><td>□</td></tr> <tr><td>□</td><td>■</td><td>□</td><td>□</td><td>□</td><td>□</td><td>□</td></tr> <tr><td></td><td>2</td><td>4</td><td>6</td><td>8</td><td>10</td><td>12</td></tr> </table>		1	3	5	7	9	11	□	■	□	□	□	□	□	□	■	□	□	□	□	□		2	4	6	8	10	12	<table style="border-collapse: collapse; margin: auto;"> <tr><td></td><td>1</td><td>3</td><td>5</td><td>7</td><td>9</td></tr> <tr><td>□</td><td>□</td><td>□</td><td>■</td><td>□</td><td>□</td></tr> <tr><td>□</td><td>■</td><td>■</td><td>■</td><td>■</td><td>□</td></tr> <tr><td></td><td>2</td><td>4</td><td>6</td><td>8</td><td>10</td></tr> </table>		1	3	5	7	9	□	□	□	■	□	□	□	■	■	■	■	□		2	4	6	8	10
	1	3	5	7	9	11																																																
□	■	□	□	□	□	□																																																
□	■	□	□	□	□	□																																																
	2	4	6	8	10	12																																																
	1	3	5	7	9																																																	
□	□	□	■	□	□																																																	
□	■	■	■	■	□																																																	
	2	4	6	8	10																																																	
RS422	<table style="border-collapse: collapse; margin: auto;"> <tr><td></td><td>1</td><td>3</td><td>5</td><td>7</td><td>9</td><td>11</td></tr> <tr><td>□</td><td>□</td><td>■</td><td>■</td><td>■</td><td>■</td><td>■</td></tr> <tr><td>□</td><td>□</td><td>■</td><td>■</td><td>■</td><td>■</td><td>■</td></tr> <tr><td></td><td>2</td><td>4</td><td>6</td><td>8</td><td>10</td><td>12</td></tr> </table>		1	3	5	7	9	11	□	□	■	■	■	■	■	□	□	■	■	■	■	■		2	4	6	8	10	12	<table style="border-collapse: collapse; margin: auto;"> <tr><td></td><td>1</td><td>3</td><td>5</td><td>7</td><td>9</td></tr> <tr><td>□</td><td>□</td><td>□</td><td>□</td><td>□</td><td>■</td></tr> <tr><td>□</td><td>□</td><td>□</td><td>□</td><td>□</td><td>■</td></tr> <tr><td></td><td>2</td><td>4</td><td>6</td><td>8</td><td>10</td></tr> </table>		1	3	5	7	9	□	□	□	□	□	■	□	□	□	□	□	■		2	4	6	8	10
	1	3	5	7	9	11																																																
□	□	■	■	■	■	■																																																
□	□	■	■	■	■	■																																																
	2	4	6	8	10	12																																																
	1	3	5	7	9																																																	
□	□	□	□	□	■																																																	
□	□	□	□	□	■																																																	
	2	4	6	8	10																																																	

▲ = Manufacturer Default Setting

2. COM3 & COM4 Power Setting

Function		JP3 (1-2) (3-4) (5-6) (7-8) (9-10) (11-12)																												
COM3 Pin10	▲RI	<table style="border-collapse: collapse; margin: auto;"> <tr><td></td><td>1</td><td>3</td><td>5</td><td>7</td><td>9</td><td>11</td></tr> <tr><td>■</td><td>□</td><td>□</td><td>□</td><td>□</td><td>□</td><td>□</td></tr> <tr><td>■</td><td>□</td><td>□</td><td>□</td><td>□</td><td>□</td><td>□</td></tr> <tr><td></td><td>2</td><td>4</td><td>6</td><td>8</td><td>10</td><td>12</td></tr> </table>		1	3	5	7	9	11	■	□	□	□	□	□	□	■	□	□	□	□	□	□		2	4	6	8	10	12
		1	3	5	7	9	11																							
	■	□	□	□	□	□	□																							
■	□	□	□	□	□	□																								
	2	4	6	8	10	12																								
+5V	<table style="border-collapse: collapse; margin: auto;"> <tr><td></td><td>1</td><td>3</td><td>5</td><td>7</td><td>9</td><td>11</td></tr> <tr><td>□</td><td>■</td><td>□</td><td>□</td><td>□</td><td>□</td><td>□</td></tr> <tr><td>□</td><td>■</td><td>□</td><td>□</td><td>□</td><td>□</td><td>□</td></tr> <tr><td></td><td>2</td><td>4</td><td>6</td><td>8</td><td>10</td><td>12</td></tr> </table>		1	3	5	7	9	11	□	■	□	□	□	□	□	□	■	□	□	□	□	□		2	4	6	8	10	12	
	1	3	5	7	9	11																								
□	■	□	□	□	□	□																								
□	■	□	□	□	□	□																								
	2	4	6	8	10	12																								
+12V	<table style="border-collapse: collapse; margin: auto;"> <tr><td></td><td>1</td><td>3</td><td>5</td><td>7</td><td>9</td><td>11</td></tr> <tr><td>□</td><td>□</td><td>■</td><td>□</td><td>□</td><td>□</td><td>□</td></tr> <tr><td>□</td><td>□</td><td>■</td><td>□</td><td>□</td><td>□</td><td>□</td></tr> <tr><td></td><td>2</td><td>4</td><td>6</td><td>8</td><td>10</td><td>12</td></tr> </table>		1	3	5	7	9	11	□	□	■	□	□	□	□	□	□	■	□	□	□	□		2	4	6	8	10	12	
	1	3	5	7	9	11																								
□	□	■	□	□	□	□																								
□	□	■	□	□	□	□																								
	2	4	6	8	10	12																								
COM4 Pin10	▲RI	<table style="border-collapse: collapse; margin: auto;"> <tr><td></td><td>1</td><td>3</td><td>5</td><td>7</td><td>9</td><td>11</td></tr> <tr><td>□</td><td>□</td><td>□</td><td>■</td><td>□</td><td>□</td><td>□</td></tr> <tr><td>□</td><td>□</td><td>□</td><td>■</td><td>□</td><td>□</td><td>□</td></tr> <tr><td></td><td>2</td><td>4</td><td>6</td><td>8</td><td>10</td><td>12</td></tr> </table>		1	3	5	7	9	11	□	□	□	■	□	□	□	□	□	□	■	□	□	□		2	4	6	8	10	12
		1	3	5	7	9	11																							
	□	□	□	■	□	□	□																							
□	□	□	■	□	□	□																								
	2	4	6	8	10	12																								
+5V	<table style="border-collapse: collapse; margin: auto;"> <tr><td></td><td>1</td><td>3</td><td>5</td><td>7</td><td>9</td><td>11</td></tr> <tr><td>□</td><td>□</td><td>□</td><td>□</td><td>□</td><td>■</td><td>□</td></tr> <tr><td>□</td><td>□</td><td>□</td><td>□</td><td>□</td><td>■</td><td>□</td></tr> <tr><td></td><td>2</td><td>4</td><td>6</td><td>8</td><td>10</td><td>12</td></tr> </table>		1	3	5	7	9	11	□	□	□	□	□	■	□	□	□	□	□	□	■	□		2	4	6	8	10	12	
	1	3	5	7	9	11																								
□	□	□	□	□	■	□																								
□	□	□	□	□	■	□																								
	2	4	6	8	10	12																								
+12V	<table style="border-collapse: collapse; margin: auto;"> <tr><td></td><td>1</td><td>3</td><td>5</td><td>7</td><td>9</td><td>11</td></tr> <tr><td>□</td><td>□</td><td>□</td><td>□</td><td>□</td><td>□</td><td>■</td></tr> <tr><td>□</td><td>□</td><td>□</td><td>□</td><td>□</td><td>□</td><td>■</td></tr> <tr><td></td><td>2</td><td>4</td><td>6</td><td>8</td><td>10</td><td>12</td></tr> </table>		1	3	5	7	9	11	□	□	□	□	□	□	■	□	□	□	□	□	□	■		2	4	6	8	10	12	
	1	3	5	7	9	11																								
□	□	□	□	□	□	■																								
□	□	□	□	□	□	■																								
	2	4	6	8	10	12																								

▲ = Manufacturer Default Setting

3. Cash Drawer Power Setting

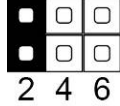
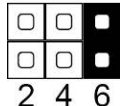
Function	JP4 (1-2) (3-4) (5-6)
+12V	1 3 5  2 4 6
▲+19V (for +24V Cash Drawer)	1 3 5  2 4 6

▲ = Manufacturer Default Setting

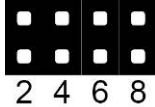
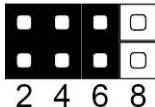
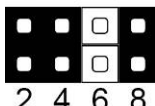
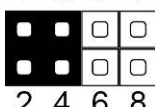
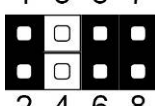

4. LCD ID Setting

Panel #	Resolution			LVDS		JP7 (1-2) (3-4) (5-6) (7-8)
				Bits	Channel	
1	640	x	480	18	Single	1 3 5 7  2 4 6 8
2	800	x	600	18	Single	1 3 5 7  2 4 6 8
3	1024	x	768	18	Single	1 3 5 7  2 4 6 8
4	1280	x	1024	24	Dual	1 3 5 7  2 4 6 8
5	1024	x	768	24	Single	1 3 5 7  2 4 6 8



Panel #	Resolution			LVDS		JP7 (1-2) (3-4) (5-6) (7-8)
				Bits	Channel	
6	800	x	600	24	Single	<pre> 1 3 5 7 ■ □ ■ □ 2 4 6 8 </pre>
7	800	x	600	18	Single	<pre> 1 3 5 7 ■ □ □ ■ 2 4 6 8 </pre>
8	800	x	600	18	Single	<pre> 1 3 5 7 ■ □ □ □ 2 4 6 8 </pre>
9	1024	x	768	24	Single	<pre> 1 3 5 7 □ ■ ■ ■ 2 4 6 8 </pre>
10	1440	x	900	24	Dual	<pre> 1 3 5 7 □ ■ ■ □ 2 4 6 8 </pre>
11	1280	x	1024	24	Dual	<pre> 1 3 5 7 □ ■ □ ■ 2 4 6 8 </pre>
12	1440	x	900	18	Dual	<pre> 1 3 5 7 □ ■ □ □ 2 4 6 8 </pre>

Remark: Panel ID #8 is only applied for Sharp 12" LQ121S1LG41 / LQ121S1LG42 panel.



5. Power Mode Setting

Function	JP6 (1-2)
▲ATX Power	
AT Power	

























6. CMOS Operation Mode

Function	JP8 (1-2)
▲CMOS Normal	
CMOS Reset	

7. USB Path Setting

Function	JP14 (1-2)
▲To Docking	
To MB	

8. System Indicator

Function	JP13 (1-2) (3-4) (5-6) (7-8)												
▲Disable	<table style="border: none; text-align: center;"> <tr> <td>1</td><td>3</td><td>5</td><td>7</td> </tr> <tr> <td></td><td></td><td></td><td></td> </tr> <tr> <td>2</td><td>4</td><td>6</td><td>8</td> </tr> </table>	1	3	5	7					2	4	6	8
1	3	5	7										
													
2	4	6	8										
Enable	<table style="border: none; text-align: center;"> <tr> <td>1</td><td>3</td><td>5</td><td>7</td> </tr> <tr> <td></td><td></td><td></td><td></td> </tr> <tr> <td>2</td><td>4</td><td>6</td><td>8</td> </tr> </table>	1	3	5	7					2	4	6	8
1	3	5	7										
													
2	4	6	8										

▲ = Manufacturer Default Setting

7-2 B98 Motherboard

7-2-1 B98 Motherboard layout

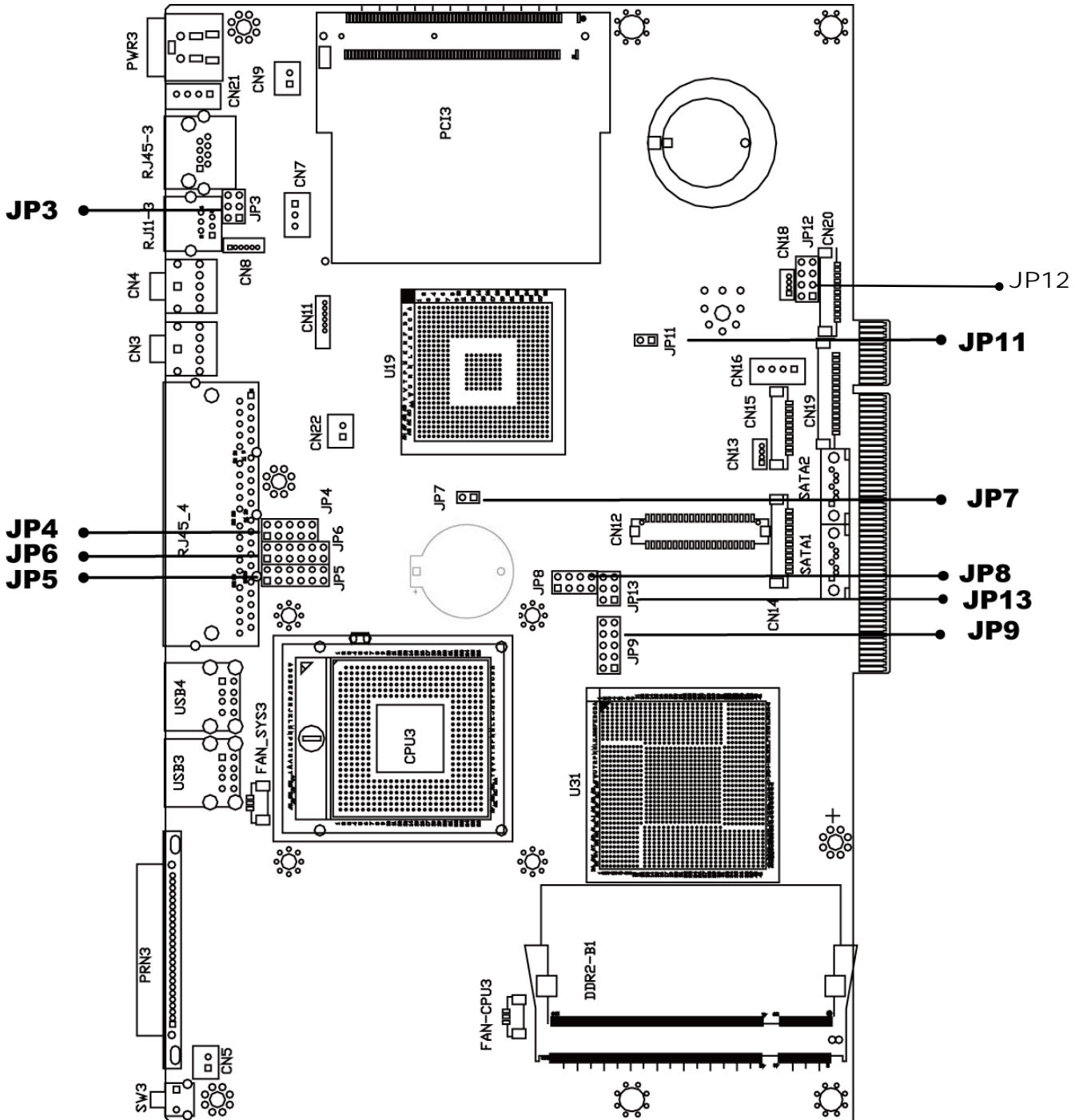

B98 V1.1

7-2-2 B98 Connector and function

Connector	Purpose
BAT3	CMOS Battery Base (Use CR2023)
CN3	Audio Line Out
CN4	MIC In
CN5	Internal Power On Switch Connector
CN8	Speaker & MIC Connector
CN11	CD-IN / Line-In Connector
CN12	LCD Interface Connector
CN14	Inverter Connector
CN15	COM5 for Touch
CN16	Power Connector For HDD
CN18	USB5
CN19	Card Reader Connector
CN21	Internal Input Power Connector
CN22	Hardware Reset
DDR2_A1	DDR2 SO-DIMM
DDR2_B1	DDR2 SO-DIMM
FAN_CPU3	CPU FAN Connector
FAN_SYS3	System FAN Connector
MINI_PCIE3	Mini PCI-E Socket
PCI3	Mini PCI Socket
PRN3	Parallel Port
PWR3	+19V Power Adaptor
RJ45_3	LAN (On Board)
RJ45_4	COM1, COM2, COM3, COM4
SATA1	SATA Connector
SATA2	SATA Connector
SKT1	SPI ROM
SW3	Power On Button
USB3	USB1, USB2
USB4	USB3, USB4
JP3	Cash Drawer Power Setting
JP4 / 6	COM2 RS232/485/422 Setting
JP5	COM3/COM4 Power Setting
JP7	CMOS Operation Mode
JP8	LCD ID Setting
JP9	VGA Port
JP11	Power Mode Setting
JP12	System Indicator
JP13	VGA Power

7-2-3 B98 Jumper Setting

1. COM2 RS232/485/422 Setting

Function	JP6 (1-2) (3-4) (5-6) (7-8) (9-10) (11-12)	JP4 (1-2) (3-4) (4-6) (5-7) (7-8) (9-10)																																												
▲RS232	<table style="margin-left: auto; margin-right: auto;"> <tr><td>1</td><td>3</td><td>5</td><td>7</td><td>9</td><td>11</td></tr> <tr><td>■</td><td>□</td><td>□</td><td>□</td><td>□</td><td>□</td></tr> <tr><td>■</td><td>□</td><td>□</td><td>□</td><td>□</td><td>□</td></tr> <tr><td>2</td><td>4</td><td>6</td><td>8</td><td>10</td><td>12</td></tr> </table>	1	3	5	7	9	11	■	□	□	□	□	□	■	□	□	□	□	□	2	4	6	8	10	12	<table style="margin-left: auto; margin-right: auto;"> <tr><td>1</td><td>3</td><td>5</td><td>7</td><td>9</td></tr> <tr><td>■</td><td>■</td><td>■</td><td>■</td><td>□</td></tr> <tr><td>■</td><td>■</td><td>□</td><td>□</td><td>□</td></tr> <tr><td>2</td><td>4</td><td>6</td><td>8</td><td>10</td></tr> </table>	1	3	5	7	9	■	■	■	■	□	■	■	□	□	□	2	4	6	8	10
1	3	5	7	9	11																																									
■	□	□	□	□	□																																									
■	□	□	□	□	□																																									
2	4	6	8	10	12																																									
1	3	5	7	9																																										
■	■	■	■	□																																										
■	■	□	□	□																																										
2	4	6	8	10																																										
RS485	<table style="margin-left: auto; margin-right: auto;"> <tr><td>1</td><td>3</td><td>5</td><td>7</td><td>9</td><td>11</td></tr> <tr><td>□</td><td>■</td><td>□</td><td>□</td><td>□</td><td>□</td></tr> <tr><td>□</td><td>■</td><td>□</td><td>□</td><td>□</td><td>□</td></tr> <tr><td>2</td><td>4</td><td>6</td><td>8</td><td>10</td><td>12</td></tr> </table>	1	3	5	7	9	11	□	■	□	□	□	□	□	■	□	□	□	□	2	4	6	8	10	12	<table style="margin-left: auto; margin-right: auto;"> <tr><td>1</td><td>3</td><td>5</td><td>7</td><td>9</td></tr> <tr><td>□</td><td>□</td><td>□</td><td>■</td><td>□</td></tr> <tr><td>□</td><td>■</td><td>■</td><td>■</td><td>□</td></tr> <tr><td>2</td><td>4</td><td>6</td><td>8</td><td>10</td></tr> </table>	1	3	5	7	9	□	□	□	■	□	□	■	■	■	□	2	4	6	8	10
1	3	5	7	9	11																																									
□	■	□	□	□	□																																									
□	■	□	□	□	□																																									
2	4	6	8	10	12																																									
1	3	5	7	9																																										
□	□	□	■	□																																										
□	■	■	■	□																																										
2	4	6	8	10																																										
RS422	<table style="margin-left: auto; margin-right: auto;"> <tr><td>1</td><td>3</td><td>5</td><td>7</td><td>9</td><td>11</td></tr> <tr><td>□</td><td>□</td><td>■</td><td>■</td><td>■</td><td>■</td></tr> <tr><td>□</td><td>□</td><td>■</td><td>■</td><td>■</td><td>■</td></tr> <tr><td>2</td><td>4</td><td>6</td><td>8</td><td>10</td><td>12</td></tr> </table>	1	3	5	7	9	11	□	□	■	■	■	■	□	□	■	■	■	■	2	4	6	8	10	12	<table style="margin-left: auto; margin-right: auto;"> <tr><td>1</td><td>3</td><td>5</td><td>7</td><td>9</td></tr> <tr><td>□</td><td>□</td><td>□</td><td>□</td><td>■</td></tr> <tr><td>□</td><td>□</td><td>□</td><td>□</td><td>■</td></tr> <tr><td>2</td><td>4</td><td>6</td><td>8</td><td>10</td></tr> </table>	1	3	5	7	9	□	□	□	□	■	□	□	□	□	■	2	4	6	8	10
1	3	5	7	9	11																																									
□	□	■	■	■	■																																									
□	□	■	■	■	■																																									
2	4	6	8	10	12																																									
1	3	5	7	9																																										
□	□	□	□	■																																										
□	□	□	□	■																																										
2	4	6	8	10																																										

▲ = Manufacturer Default Setting

2. System Indicator

Function	JP12 (1-2) (3-4) 5-6)(7-8)																
Disable	<table style="margin-left: auto; margin-right: auto;"> <tr><td>1</td><td>3</td><td>5</td><td>7</td></tr> <tr><td>■</td><td>■</td><td>□</td><td>□</td></tr> <tr><td>■</td><td>■</td><td>□</td><td>□</td></tr> <tr><td>2</td><td>4</td><td>6</td><td>8</td></tr> </table>	1	3	5	7	■	■	□	□	■	■	□	□	2	4	6	8
1	3	5	7														
■	■	□	□														
■	■	□	□														
2	4	6	8														
▲Enable	<table style="margin-left: auto; margin-right: auto;"> <tr><td>1</td><td>3</td><td>5</td><td>7</td></tr> <tr><td>□</td><td>□</td><td>■</td><td>■</td></tr> <tr><td>□</td><td>□</td><td>■</td><td>■</td></tr> <tr><td>2</td><td>4</td><td>6</td><td>8</td></tr> </table>	1	3	5	7	□	□	■	■	□	□	■	■	2	4	6	8
1	3	5	7														
□	□	■	■														
□	□	■	■														
2	4	6	8														

3. COM3 & COM4 Power Setting

Function		JP5 (1-2) (3-4) (5-6) (7-8) (9-10) (11-12)																								
COM3 Pin10	▲RI	<table border="1"> <tr><td>1</td><td>3</td><td>5</td><td>7</td><td>9</td><td>11</td></tr> <tr><td>■</td><td>□</td><td>□</td><td>□</td><td>□</td><td>□</td></tr> <tr><td>■</td><td>□</td><td>□</td><td>□</td><td>□</td><td>□</td></tr> <tr><td>2</td><td>4</td><td>6</td><td>8</td><td>10</td><td>12</td></tr> </table>	1	3	5	7	9	11	■	□	□	□	□	□	■	□	□	□	□	□	2	4	6	8	10	12
	1	3	5	7	9	11																				
	■	□	□	□	□	□																				
■	□	□	□	□	□																					
2	4	6	8	10	12																					
+5V	<table border="1"> <tr><td>1</td><td>3</td><td>5</td><td>7</td><td>9</td><td>11</td></tr> <tr><td>□</td><td>■</td><td>□</td><td>□</td><td>□</td><td>□</td></tr> <tr><td>□</td><td>■</td><td>□</td><td>□</td><td>□</td><td>□</td></tr> <tr><td>2</td><td>4</td><td>6</td><td>8</td><td>10</td><td>12</td></tr> </table>	1	3	5	7	9	11	□	■	□	□	□	□	□	■	□	□	□	□	2	4	6	8	10	12	
1	3	5	7	9	11																					
□	■	□	□	□	□																					
□	■	□	□	□	□																					
2	4	6	8	10	12																					
+12V	<table border="1"> <tr><td>1</td><td>3</td><td>5</td><td>7</td><td>9</td><td>11</td></tr> <tr><td>□</td><td>□</td><td>■</td><td>□</td><td>□</td><td>□</td></tr> <tr><td>□</td><td>□</td><td>■</td><td>□</td><td>□</td><td>□</td></tr> <tr><td>2</td><td>4</td><td>6</td><td>8</td><td>10</td><td>12</td></tr> </table>	1	3	5	7	9	11	□	□	■	□	□	□	□	□	■	□	□	□	2	4	6	8	10	12	
1	3	5	7	9	11																					
□	□	■	□	□	□																					
□	□	■	□	□	□																					
2	4	6	8	10	12																					
COM4 Pin10	▲RI	<table border="1"> <tr><td>1</td><td>3</td><td>5</td><td>7</td><td>9</td><td>11</td></tr> <tr><td>□</td><td>□</td><td>□</td><td>■</td><td>□</td><td>□</td></tr> <tr><td>□</td><td>□</td><td>□</td><td>■</td><td>□</td><td>□</td></tr> <tr><td>2</td><td>4</td><td>6</td><td>8</td><td>10</td><td>12</td></tr> </table>	1	3	5	7	9	11	□	□	□	■	□	□	□	□	□	■	□	□	2	4	6	8	10	12
	1	3	5	7	9	11																				
	□	□	□	■	□	□																				
□	□	□	■	□	□																					
2	4	6	8	10	12																					
+5V	<table border="1"> <tr><td>1</td><td>3</td><td>5</td><td>7</td><td>9</td><td>11</td></tr> <tr><td>□</td><td>□</td><td>□</td><td>□</td><td>■</td><td>□</td></tr> <tr><td>□</td><td>□</td><td>□</td><td>□</td><td>■</td><td>□</td></tr> <tr><td>2</td><td>4</td><td>6</td><td>8</td><td>10</td><td>12</td></tr> </table>	1	3	5	7	9	11	□	□	□	□	■	□	□	□	□	□	■	□	2	4	6	8	10	12	
1	3	5	7	9	11																					
□	□	□	□	■	□																					
□	□	□	□	■	□																					
2	4	6	8	10	12																					
+12V	<table border="1"> <tr><td>1</td><td>3</td><td>5</td><td>7</td><td>9</td><td>11</td></tr> <tr><td>□</td><td>□</td><td>□</td><td>□</td><td>□</td><td>■</td></tr> <tr><td>□</td><td>□</td><td>□</td><td>□</td><td>□</td><td>■</td></tr> <tr><td>2</td><td>4</td><td>6</td><td>8</td><td>10</td><td>12</td></tr> </table>	1	3	5	7	9	11	□	□	□	□	□	■	□	□	□	□	□	■	2	4	6	8	10	12	
1	3	5	7	9	11																					
□	□	□	□	□	■																					
□	□	□	□	□	■																					
2	4	6	8	10	12																					

▲ = Manufacturer Default Setting

4. Cash Drawer Power Setting

Function	JP3 (1-2) (3-4) 5-6												
+12V	<table style="border-collapse: collapse; margin: auto;"> <tr> <td style="padding: 0 10px;">1</td> <td style="padding: 0 10px;">3</td> <td style="padding: 0 10px;">5</td> </tr> <tr> <td style="text-align: center;"><input checked="" type="checkbox"/></td> <td style="text-align: center;"><input type="checkbox"/></td> <td style="text-align: center;"><input type="checkbox"/></td> </tr> <tr> <td style="text-align: center;"><input checked="" type="checkbox"/></td> <td style="text-align: center;"><input type="checkbox"/></td> <td style="text-align: center;"><input type="checkbox"/></td> </tr> <tr> <td style="padding: 0 10px;">2</td> <td style="padding: 0 10px;">4</td> <td style="padding: 0 10px;">6</td> </tr> </table>	1	3	5	<input checked="" type="checkbox"/>	<input type="checkbox"/>	<input type="checkbox"/>	<input checked="" type="checkbox"/>	<input type="checkbox"/>	<input type="checkbox"/>	2	4	6
1	3	5											
<input checked="" type="checkbox"/>	<input type="checkbox"/>	<input type="checkbox"/>											
<input checked="" type="checkbox"/>	<input type="checkbox"/>	<input type="checkbox"/>											
2	4	6											
<p style="text-align: center;">▲+19V (for +24V Cash Drawer)</p>	<table style="border-collapse: collapse; margin: auto;"> <tr> <td style="padding: 0 10px;">1</td> <td style="padding: 0 10px;">3</td> <td style="padding: 0 10px;">5</td> </tr> <tr> <td style="text-align: center;"><input type="checkbox"/></td> <td style="text-align: center;"><input type="checkbox"/></td> <td style="text-align: center;"><input checked="" type="checkbox"/></td> </tr> <tr> <td style="text-align: center;"><input type="checkbox"/></td> <td style="text-align: center;"><input type="checkbox"/></td> <td style="text-align: center;"><input checked="" type="checkbox"/></td> </tr> <tr> <td style="padding: 0 10px;">2</td> <td style="padding: 0 10px;">4</td> <td style="padding: 0 10px;">6</td> </tr> </table>	1	3	5	<input type="checkbox"/>	<input type="checkbox"/>	<input checked="" type="checkbox"/>	<input type="checkbox"/>	<input type="checkbox"/>	<input checked="" type="checkbox"/>	2	4	6
1	3	5											
<input type="checkbox"/>	<input type="checkbox"/>	<input checked="" type="checkbox"/>											
<input type="checkbox"/>	<input type="checkbox"/>	<input checked="" type="checkbox"/>											
2	4	6											

▲ = Manufacturer Default Setting

5. Power Mode Setting

Function	JP11 (1-2)		
▲ATX Power	<table style="border-collapse: collapse; margin: auto;"> <tr> <td style="text-align: center;"><input type="checkbox"/></td> </tr> <tr> <td style="text-align: center;"><input type="checkbox"/></td> </tr> </table>	<input type="checkbox"/>	<input type="checkbox"/>
<input type="checkbox"/>			
<input type="checkbox"/>			
AT Power	<table style="border-collapse: collapse; margin: auto;"> <tr> <td style="text-align: center;"><input checked="" type="checkbox"/></td> </tr> <tr> <td style="text-align: center;"><input type="checkbox"/></td> </tr> </table>	<input checked="" type="checkbox"/>	<input type="checkbox"/>
<input checked="" type="checkbox"/>			
<input type="checkbox"/>			

6. CMOS Operation Mode

Function	JP7 (1-2)		
▲CMOS Normal	<table style="border-collapse: collapse; margin: auto;"> <tr> <td style="text-align: center;"><input type="checkbox"/></td> </tr> <tr> <td style="text-align: center;"><input type="checkbox"/></td> </tr> </table>	<input type="checkbox"/>	<input type="checkbox"/>
<input type="checkbox"/>			
<input type="checkbox"/>			
CMOS Reset	<table style="border-collapse: collapse; margin: auto;"> <tr> <td style="text-align: center;"><input checked="" type="checkbox"/></td> </tr> <tr> <td style="text-align: center;"><input type="checkbox"/></td> </tr> </table>	<input checked="" type="checkbox"/>	<input type="checkbox"/>
<input checked="" type="checkbox"/>			
<input type="checkbox"/>			

▲ = Manufacturer Default Setting

Note:



7. LCD ID Setting

Panel #	Resolution	LVDS		Output Interface	JP8 (1-2) (3-4) (5-6) (7-8)																				
		Bits	Channel																						
1	1366 x 768	24	Single	LVDS	<table style="border-collapse: collapse; text-align: center;"> <tr><td></td><td>1</td><td>3</td><td>5</td><td>7</td></tr> <tr><td>□</td><td>□</td><td>■</td><td>■</td><td></td></tr> <tr><td>□</td><td>□</td><td>■</td><td>■</td><td></td></tr> <tr><td></td><td>2</td><td>4</td><td>6</td><td>8</td></tr> </table>		1	3	5	7	□	□	■	■		□	□	■	■			2	4	6	8
	1	3	5	7																					
□	□	■	■																						
□	□	■	■																						
	2	4	6	8																					
2	1440 x 900	24	Dual	LVDS	<table style="border-collapse: collapse; text-align: center;"> <tr><td></td><td>1</td><td>3</td><td>5</td><td>7</td></tr> <tr><td>□</td><td>□</td><td>■</td><td>□</td><td></td></tr> <tr><td>□</td><td>□</td><td>■</td><td>□</td><td></td></tr> <tr><td></td><td>2</td><td>4</td><td>6</td><td>8</td></tr> </table>		1	3	5	7	□	□	■	□		□	□	■	□			2	4	6	8
	1	3	5	7																					
□	□	■	□																						
□	□	■	□																						
	2	4	6	8																					
4	1920 x 1080	24	Dual	LVDS	<table style="border-collapse: collapse; text-align: center;"> <tr><td></td><td>1</td><td>3</td><td>5</td><td>7</td></tr> <tr><td>□</td><td>□</td><td>□</td><td>□</td><td></td></tr> <tr><td>□</td><td>□</td><td>□</td><td>□</td><td></td></tr> <tr><td></td><td>2</td><td>4</td><td>6</td><td>8</td></tr> </table>		1	3	5	7	□	□	□	□		□	□	□	□			2	4	6	8
	1	3	5	7																					
□	□	□	□																						
□	□	□	□																						
	2	4	6	8																					
5	1024 x 768	24	Single	LVDS	<table style="border-collapse: collapse; text-align: center;"> <tr><td></td><td>1</td><td>3</td><td>5</td><td>7</td></tr> <tr><td>□</td><td>■</td><td>■</td><td>■</td><td></td></tr> <tr><td>□</td><td>■</td><td>■</td><td>■</td><td></td></tr> <tr><td></td><td>2</td><td>4</td><td>6</td><td>8</td></tr> </table>		1	3	5	7	□	■	■	■		□	■	■	■			2	4	6	8
	1	3	5	7																					
□	■	■	■																						
□	■	■	■																						
	2	4	6	8																					
6	1280 x 1024	24	Dual	LVDS	<table style="border-collapse: collapse; text-align: center;"> <tr><td></td><td>1</td><td>3</td><td>5</td><td>7</td></tr> <tr><td>□</td><td>■</td><td>■</td><td>□</td><td></td></tr> <tr><td>□</td><td>■</td><td>■</td><td>□</td><td></td></tr> <tr><td></td><td>2</td><td>4</td><td>6</td><td>8</td></tr> </table>		1	3	5	7	□	■	■	□		□	■	■	□			2	4	6	8
	1	3	5	7																					
□	■	■	□																						
□	■	■	□																						
	2	4	6	8																					
7	800 x 600	24	Single	LVDS	<table style="border-collapse: collapse; text-align: center;"> <tr><td></td><td>1</td><td>3</td><td>5</td><td>7</td></tr> <tr><td>□</td><td>■</td><td>□</td><td>■</td><td></td></tr> <tr><td>□</td><td>■</td><td>□</td><td>■</td><td></td></tr> <tr><td></td><td>2</td><td>4</td><td>6</td><td>8</td></tr> </table>		1	3	5	7	□	■	□	■		□	■	□	■			2	4	6	8
	1	3	5	7																					
□	■	□	■																						
□	■	□	■																						
	2	4	6	8																					
9	1024 x 768	18	Single	LVDS	<table style="border-collapse: collapse; text-align: center;"> <tr><td></td><td>1</td><td>3</td><td>5</td><td>7</td></tr> <tr><td>■</td><td>□</td><td>■</td><td>■</td><td></td></tr> <tr><td>■</td><td>□</td><td>■</td><td>■</td><td></td></tr> <tr><td></td><td>2</td><td>4</td><td>6</td><td>8</td></tr> </table>		1	3	5	7	■	□	■	■		■	□	■	■			2	4	6	8
	1	3	5	7																					
■	□	■	■																						
■	□	■	■																						
	2	4	6	8																					
11	800 x 600	18	Single	LVDS	<table style="border-collapse: collapse; text-align: center;"> <tr><td></td><td>1</td><td>3</td><td>5</td><td>7</td></tr> <tr><td>■</td><td>□</td><td>□</td><td>■</td><td></td></tr> <tr><td>■</td><td>□</td><td>□</td><td>■</td><td></td></tr> <tr><td></td><td>2</td><td>4</td><td>6</td><td>8</td></tr> </table>		1	3	5	7	■	□	□	■		■	□	□	■			2	4	6	8
	1	3	5	7																					
■	□	□	■																						
■	□	□	■																						
	2	4	6	8																					
12	800 x 600	18	Single	LVDS	<table style="border-collapse: collapse; text-align: center;"> <tr><td></td><td>1</td><td>3</td><td>5</td><td>7</td></tr> <tr><td>■</td><td>■</td><td>□</td><td>□</td><td></td></tr> <tr><td>■</td><td>■</td><td>□</td><td>□</td><td></td></tr> <tr><td></td><td>2</td><td>4</td><td>6</td><td>8</td></tr> </table>		1	3	5	7	■	■	□	□		■	■	□	□			2	4	6	8
	1	3	5	7																					
■	■	□	□																						
■	■	□	□																						
	2	4	6	8																					
				CRT	<table style="border-collapse: collapse; text-align: center;"> <tr><td></td><td>1</td><td>3</td><td>5</td><td>7</td></tr> <tr><td>■</td><td>□</td><td>□</td><td>□</td><td></td></tr> <tr><td>■</td><td>□</td><td>□</td><td>□</td><td></td></tr> <tr><td></td><td>2</td><td>4</td><td>6</td><td>8</td></tr> </table>		1	3	5	7	■	□	□	□		■	□	□	□			2	4	6	8
	1	3	5	7																					
■	□	□	□																						
■	□	□	□																						
	2	4	6	8																					

Remark: Panel ID #12 is only applied for Sharp 12" LQ121S1LG41 / LQ121S1LG42 panel.

Note:   Open   SHORT

7-3 B68 Motherboard

7-3-1 B68 Motherboard Layout

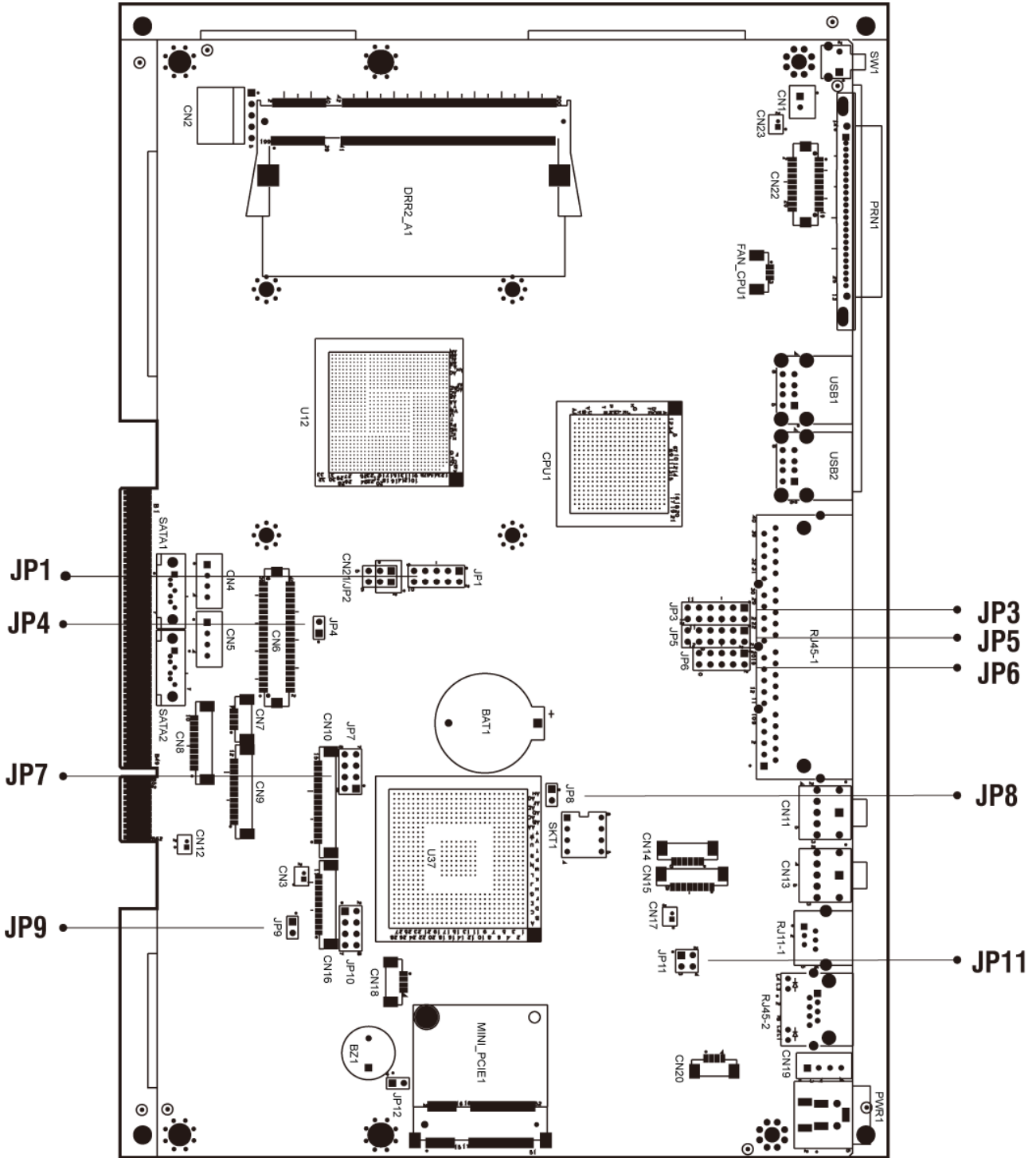

B68v 1.0

7-3-2 B68 Connector and Function

Connector	Purpose
BAT1	CMOS Battery Base (Use CR2023)
CN1	Power On Button
CN2	Touch Sensor
CN3	Power LED
CN4	SATA1 HDD Power Connector
CN5	SATA2 HDD Power Connector
CN6	LCD Interface Connector
CN7	IrDA Connector
CN8	For External Touch Connector
CN9	Inverter Connector
CN10	Card Reader Connector
CN11	Line Out
CN12	LED Power
CN13	MIC In
CN14	Speaker & MIC CONN
CN15	CD-IN CONN
CN17	LAN LED
CN18	USB5
CN19	DC-Jack
CN20	PS2 KEYBOARD
DDR2_A1	DDR2 SO-DIMM1
DDR2_A2	DDR2 SO-DIMM2
PRN1	Parallel Port
PWR1	+19V Power Adaptor
RJ11_1	Cash Drawer Connector
RJ45_1	COM1, COM2, COM3, COM4
RJ45_2	LAN (on Board)
SATA1	SATA Connector
SATA2	SATA Connector
SKT1	SPI ROM
USB1	USB1, USB2
USB2	USB3, USB4
SW1	Power On Bottom
JP1	CRT Connector
JP3	COM3/COM4 Power Setting
JP4	VGA Power Setting
JP5 / 6	COM2 RS232/485/422 Setting
JP7	LCD ID Setting
JP8	RTC Reset
JP9	Power Mode Setting
JP11	Cash Drawer Power Setting

7-3-3 B68 Jumper Setting

1. COM2 RS232/485/422 Setting

Function	JP6 (1-2, 3-4, 4-6, 5-6, 7-8, 9-10)	JP5 (1-2, 3-4, 5-6, 7-8, 9-10, 11-12)																																												
▲RS232	<table style="margin-left: auto; margin-right: auto;"> <tr><td>1</td><td>3</td><td>5</td><td>7</td><td>9</td></tr> <tr><td>■</td><td>■</td><td>■</td><td>■</td><td>□</td></tr> <tr><td>■</td><td>■</td><td>□</td><td>□</td><td>□</td></tr> <tr><td>2</td><td>4</td><td>6</td><td>8</td><td>10</td></tr> </table>	1	3	5	7	9	■	■	■	■	□	■	■	□	□	□	2	4	6	8	10	<table style="margin-left: auto; margin-right: auto;"> <tr><td>1</td><td>3</td><td>5</td><td>7</td><td>9</td><td>11</td></tr> <tr><td>■</td><td>□</td><td>□</td><td>□</td><td>□</td><td>□</td></tr> <tr><td>■</td><td>□</td><td>□</td><td>□</td><td>□</td><td>□</td></tr> <tr><td>2</td><td>4</td><td>6</td><td>8</td><td>10</td><td>12</td></tr> </table>	1	3	5	7	9	11	■	□	□	□	□	□	■	□	□	□	□	□	2	4	6	8	10	12
1	3	5	7	9																																										
■	■	■	■	□																																										
■	■	□	□	□																																										
2	4	6	8	10																																										
1	3	5	7	9	11																																									
■	□	□	□	□	□																																									
■	□	□	□	□	□																																									
2	4	6	8	10	12																																									
RS485	<table style="margin-left: auto; margin-right: auto;"> <tr><td>1</td><td>3</td><td>5</td><td>7</td><td>9</td></tr> <tr><td>□</td><td>□</td><td>□</td><td>■</td><td>□</td></tr> <tr><td>□</td><td>■</td><td>■</td><td>■</td><td>□</td></tr> <tr><td>2</td><td>4</td><td>6</td><td>8</td><td>10</td></tr> </table>	1	3	5	7	9	□	□	□	■	□	□	■	■	■	□	2	4	6	8	10	<table style="margin-left: auto; margin-right: auto;"> <tr><td>1</td><td>3</td><td>5</td><td>7</td><td>9</td><td>11</td></tr> <tr><td>□</td><td>■</td><td>□</td><td>□</td><td>□</td><td>□</td></tr> <tr><td>□</td><td>■</td><td>□</td><td>□</td><td>□</td><td>□</td></tr> <tr><td>2</td><td>4</td><td>6</td><td>8</td><td>10</td><td>12</td></tr> </table>	1	3	5	7	9	11	□	■	□	□	□	□	□	■	□	□	□	□	2	4	6	8	10	12
1	3	5	7	9																																										
□	□	□	■	□																																										
□	■	■	■	□																																										
2	4	6	8	10																																										
1	3	5	7	9	11																																									
□	■	□	□	□	□																																									
□	■	□	□	□	□																																									
2	4	6	8	10	12																																									
RS422	<table style="margin-left: auto; margin-right: auto;"> <tr><td>1</td><td>3</td><td>5</td><td>7</td><td>9</td></tr> <tr><td>□</td><td>□</td><td>□</td><td>□</td><td>■</td></tr> <tr><td>□</td><td>□</td><td>□</td><td>□</td><td>■</td></tr> <tr><td>2</td><td>4</td><td>6</td><td>8</td><td>10</td></tr> </table>	1	3	5	7	9	□	□	□	□	■	□	□	□	□	■	2	4	6	8	10	<table style="margin-left: auto; margin-right: auto;"> <tr><td>1</td><td>3</td><td>5</td><td>7</td><td>9</td><td>11</td></tr> <tr><td>□</td><td>□</td><td>■</td><td>■</td><td>■</td><td>■</td></tr> <tr><td>□</td><td>□</td><td>■</td><td>■</td><td>■</td><td>■</td></tr> <tr><td>2</td><td>4</td><td>6</td><td>8</td><td>10</td><td>12</td></tr> </table>	1	3	5	7	9	11	□	□	■	■	■	■	□	□	■	■	■	■	2	4	6	8	10	12
1	3	5	7	9																																										
□	□	□	□	■																																										
□	□	□	□	■																																										
2	4	6	8	10																																										
1	3	5	7	9	11																																									
□	□	■	■	■	■																																									
□	□	■	■	■	■																																									
2	4	6	8	10	12																																									

▲ = Manufacturer Default Setting

2. Cash Drawer Power Setting

Function	JP11 (1-2, 3-4)								
+12V	<table style="margin-left: auto; margin-right: auto;"> <tr><td>1</td><td>3</td></tr> <tr><td>■</td><td>□</td></tr> <tr><td>■</td><td>□</td></tr> <tr><td>2</td><td>4</td></tr> </table>	1	3	■	□	■	□	2	4
1	3								
■	□								
■	□								
2	4								
▲+19V (for +24V Cash Drawer)	<table style="margin-left: auto; margin-right: auto;"> <tr><td>1</td><td>3</td></tr> <tr><td>□</td><td>■</td></tr> <tr><td>□</td><td>■</td></tr> <tr><td>2</td><td>4</td></tr> </table>	1	3	□	■	□	■	2	4
1	3								
□	■								
□	■								
2	4								

3. COM3 & COM4 Power Setting



Function		JP3 (1-2, 3-4, 5-6, 7-8, 9-10,11-12)																												
COM3 Pin30	▲RI	<table border="1"> <tr><td></td><td>1</td><td>3</td><td>5</td><td>7</td><td>9</td><td>11</td></tr> <tr><td>■</td><td>□</td><td>□</td><td>□</td><td>□</td><td>□</td><td>□</td></tr> <tr><td>■</td><td>□</td><td>□</td><td>□</td><td>□</td><td>□</td><td>□</td></tr> <tr><td></td><td>2</td><td>4</td><td>6</td><td>8</td><td>10</td><td>12</td></tr> </table>		1	3	5	7	9	11	■	□	□	□	□	□	□	■	□	□	□	□	□	□		2	4	6	8	10	12
		1	3	5	7	9	11																							
	■	□	□	□	□	□	□																							
■	□	□	□	□	□	□																								
	2	4	6	8	10	12																								
+5V	<table border="1"> <tr><td></td><td>1</td><td>3</td><td>5</td><td>7</td><td>9</td><td>11</td></tr> <tr><td>□</td><td>■</td><td>□</td><td>□</td><td>□</td><td>□</td><td>□</td></tr> <tr><td>□</td><td>■</td><td>□</td><td>□</td><td>□</td><td>□</td><td>□</td></tr> <tr><td></td><td>2</td><td>4</td><td>6</td><td>8</td><td>10</td><td>12</td></tr> </table>		1	3	5	7	9	11	□	■	□	□	□	□	□	□	■	□	□	□	□	□		2	4	6	8	10	12	
	1	3	5	7	9	11																								
□	■	□	□	□	□	□																								
□	■	□	□	□	□	□																								
	2	4	6	8	10	12																								
+12V	<table border="1"> <tr><td></td><td>1</td><td>3</td><td>5</td><td>7</td><td>9</td><td>11</td></tr> <tr><td>□</td><td>□</td><td>■</td><td>□</td><td>□</td><td>□</td><td>□</td></tr> <tr><td>□</td><td>□</td><td>■</td><td>□</td><td>□</td><td>□</td><td>□</td></tr> <tr><td></td><td>2</td><td>4</td><td>6</td><td>8</td><td>10</td><td>12</td></tr> </table>		1	3	5	7	9	11	□	□	■	□	□	□	□	□	□	■	□	□	□	□		2	4	6	8	10	12	
	1	3	5	7	9	11																								
□	□	■	□	□	□	□																								
□	□	■	□	□	□	□																								
	2	4	6	8	10	12																								
COM4 Pin40	▲RI	<table border="1"> <tr><td></td><td>1</td><td>3</td><td>5</td><td>7</td><td>9</td><td>11</td></tr> <tr><td>□</td><td>□</td><td>□</td><td>■</td><td>□</td><td>□</td><td>□</td></tr> <tr><td>□</td><td>□</td><td>□</td><td>■</td><td>□</td><td>□</td><td>□</td></tr> <tr><td></td><td>2</td><td>4</td><td>6</td><td>8</td><td>10</td><td>12</td></tr> </table>		1	3	5	7	9	11	□	□	□	■	□	□	□	□	□	□	■	□	□	□		2	4	6	8	10	12
		1	3	5	7	9	11																							
	□	□	□	■	□	□	□																							
□	□	□	■	□	□	□																								
	2	4	6	8	10	12																								
+5V	<table border="1"> <tr><td></td><td>1</td><td>3</td><td>5</td><td>7</td><td>9</td><td>11</td></tr> <tr><td>□</td><td>□</td><td>□</td><td>□</td><td>■</td><td>□</td><td>□</td></tr> <tr><td>□</td><td>□</td><td>□</td><td>□</td><td>■</td><td>□</td><td>□</td></tr> <tr><td></td><td>2</td><td>4</td><td>6</td><td>8</td><td>10</td><td>12</td></tr> </table>		1	3	5	7	9	11	□	□	□	□	■	□	□	□	□	□	□	■	□	□		2	4	6	8	10	12	
	1	3	5	7	9	11																								
□	□	□	□	■	□	□																								
□	□	□	□	■	□	□																								
	2	4	6	8	10	12																								
+12V	<table border="1"> <tr><td></td><td>1</td><td>3</td><td>5</td><td>7</td><td>9</td><td>11</td></tr> <tr><td>□</td><td>□</td><td>□</td><td>□</td><td>□</td><td>□</td><td>■</td></tr> <tr><td>□</td><td>□</td><td>□</td><td>□</td><td>□</td><td>□</td><td>■</td></tr> <tr><td></td><td>2</td><td>4</td><td>6</td><td>8</td><td>10</td><td>12</td></tr> </table>		1	3	5	7	9	11	□	□	□	□	□	□	■	□	□	□	□	□	□	■		2	4	6	8	10	12	
	1	3	5	7	9	11																								
□	□	□	□	□	□	■																								
□	□	□	□	□	□	■																								
	2	4	6	8	10	12																								

▲ = Manufacturer Default Setting



4. Power Mode Setting

Function	JP9 (1-2)		
▲ATX Power	<table border="1"> <tr><td>□</td></tr> <tr><td>□</td></tr> </table>	□	□
□			
□			
AT Power	<table border="1"> <tr><td>■</td></tr> <tr><td>■</td></tr> </table>	■	■
■			
■			

5. CMOS Operation Mode

Function	JP8 (1-2)
▲ CMOS Normal	
CMOS Reset	

6. VGA Power Setting

Function	JP4 (1-2)
▲ No Power	
+12V	



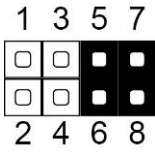
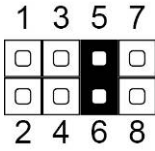
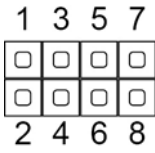
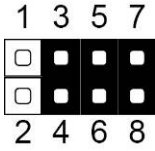

▲ = Manufacturer Default Setting

7. LCD ID Setting

Panel #	Resolution	LVDS		Output Interface	JP7 (1-2) (3-4) (5-6) (7-8)
		Bits	Channel		
1	1366 x 768	24	Single	LVDS	
2	1440 x 900	24	Dual	LVDS	
4	1920 x 1080	24	Dual	LVDS	
5	1024 x 768	24	Single	LVDS	

Panel #	Resolution	LVDS		Output Interface	JP7 (1-2) (3-4) (5-6) (7-8)																
		Bits	Channel																		
6	1280 x 1024	24	Dual	LVDS	<table style="border-collapse: collapse; text-align: center;"> <tr><td>1</td><td>3</td><td>5</td><td>7</td></tr> <tr><td>□</td><td>■</td><td>■</td><td>□</td></tr> <tr><td>□</td><td>■</td><td>■</td><td>□</td></tr> <tr><td>2</td><td>4</td><td>6</td><td>8</td></tr> </table>	1	3	5	7	□	■	■	□	□	■	■	□	2	4	6	8
1	3	5	7																		
□	■	■	□																		
□	■	■	□																		
2	4	6	8																		
7	800 x 600	24	Single	LVDS	<table style="border-collapse: collapse; text-align: center;"> <tr><td>1</td><td>3</td><td>5</td><td>7</td></tr> <tr><td>□</td><td>■</td><td>□</td><td>■</td></tr> <tr><td>□</td><td>■</td><td>□</td><td>■</td></tr> <tr><td>2</td><td>4</td><td>6</td><td>8</td></tr> </table>	1	3	5	7	□	■	□	■	□	■	□	■	2	4	6	8
1	3	5	7																		
□	■	□	■																		
□	■	□	■																		
2	4	6	8																		
9	1024 x 768	18	Single	LVDS	<table style="border-collapse: collapse; text-align: center;"> <tr><td>1</td><td>3</td><td>5</td><td>7</td></tr> <tr><td>■</td><td>■</td><td>■</td><td>■</td></tr> <tr><td>■</td><td>■</td><td>■</td><td>■</td></tr> <tr><td>2</td><td>4</td><td>6</td><td>8</td></tr> </table>	1	3	5	7	■	■	■	■	■	■	■	■	2	4	6	8
1	3	5	7																		
■	■	■	■																		
■	■	■	■																		
2	4	6	8																		
11	800 x 600	18	Single	LVDS	<table style="border-collapse: collapse; text-align: center;"> <tr><td>1</td><td>3</td><td>5</td><td>7</td></tr> <tr><td>■</td><td>■</td><td>□</td><td>■</td></tr> <tr><td>■</td><td>■</td><td>□</td><td>■</td></tr> <tr><td>2</td><td>4</td><td>6</td><td>8</td></tr> </table>	1	3	5	7	■	■	□	■	■	■	□	■	2	4	6	8
1	3	5	7																		
■	■	□	■																		
■	■	□	■																		
2	4	6	8																		
12	800 x 600	18	Single	LVDS	<table style="border-collapse: collapse; text-align: center;"> <tr><td>1</td><td>3</td><td>5</td><td>7</td></tr> <tr><td>■</td><td>■</td><td>□</td><td>□</td></tr> <tr><td>■</td><td>■</td><td>□</td><td>□</td></tr> <tr><td>2</td><td>4</td><td>6</td><td>8</td></tr> </table>	1	3	5	7	■	■	□	□	■	■	□	□	2	4	6	8
1	3	5	7																		
■	■	□	□																		
■	■	□	□																		
2	4	6	8																		
				CRT	<table style="border-collapse: collapse; text-align: center;"> <tr><td>1</td><td>3</td><td>5</td><td>7</td></tr> <tr><td>■</td><td>□</td><td>□</td><td>□</td></tr> <tr><td>■</td><td>□</td><td>□</td><td>□</td></tr> <tr><td>2</td><td>4</td><td>6</td><td>8</td></tr> </table>	1	3	5	7	■	□	□	□	■	□	□	□	2	4	6	8
1	3	5	7																		
■	□	□	□																		
■	□	□	□																		
2	4	6	8																		

Remark: Panel ID #12 is only applied for Sharp 12" LQ121S1LG41 / LQ121S1LG42 panel.

Note:    

OPEN SHORT

7-4 C48 Motherboard

7-4-1 C48 Motherboard Layout

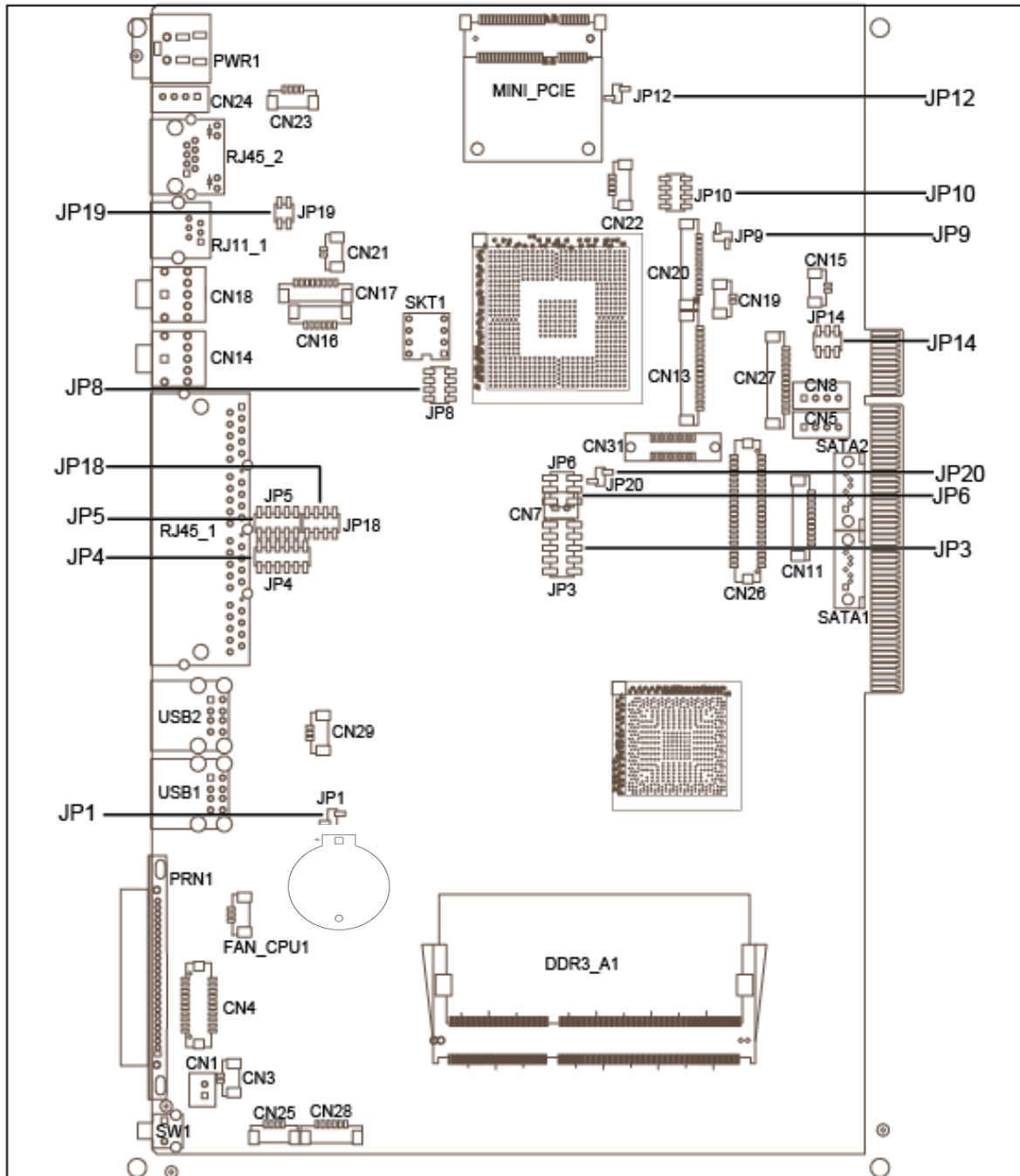

C48 V2.1 TOP LAYER

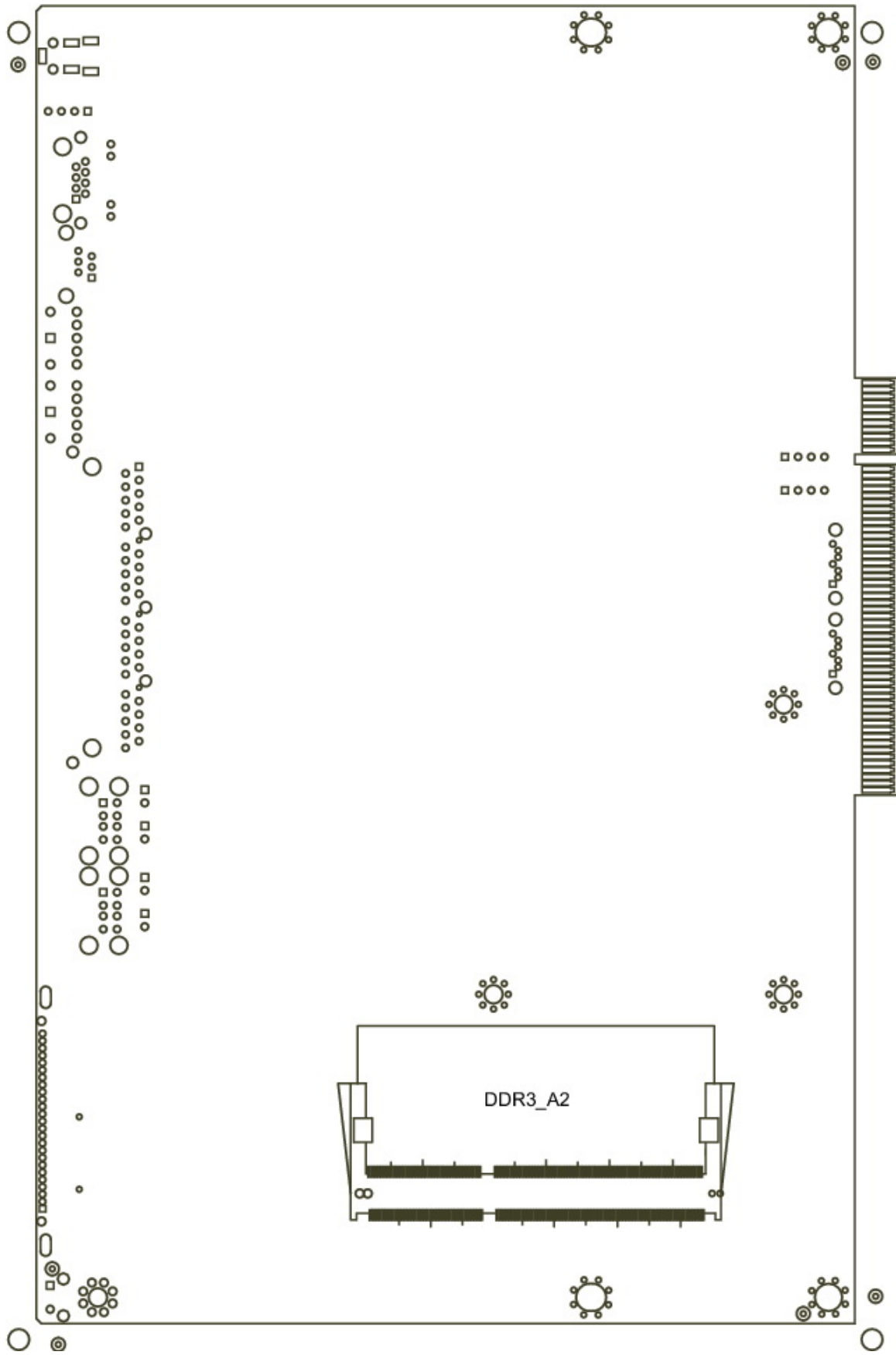

C48 V2.1 BOTTOM LAYER

7-4-2 C48 Connector and Function

Connector	Purpose
CN1	Power Button Connector
CN3	Printer Port Reset
CN4	Printer Port
CN5/8	HDD Power
CN11	COM5 For Touch
CN13	Card Reader Connector
CN14	Line out
CN15	HDD LED
CN16	Speaker & MIC
CN18	MIC IN
CN20/JP10	System Indicator
CN22	USB Port
CN23	PS2 KEYBOARD
CN26	LVDS
CN27	Inverter Connector
CN29	System Fan
DDR3_A1	DDR3 SO-DIMM1
DDR3_A2	DDR3 SO-DIMM2
PRN1	Parallel Port
PWR1	+19V DC Jack
RJ11_1	Cash Drawer Connector
RJ45_1	COM1, COM2, COM3, COM4
RJ45_2	LAN
SATA1	SATA Connector
SATA2	SATA Connector
USB1	USB1, USB2
USB2	USB3, USB4
SW1	Power Button
JP1	CMOS Operation Mode
JP3/6	VGA Port
JP4/5	COM2 RS232/485/422 Setting
JP8	LCD ID Setting
JP9	Power Mode Setting
JP12	System Reset
JP14	Inverter Selection
JP18	COM3/4 Power Setting
JP19	Cash Drawer Power Setting

7-5 C48 Jumper & BIOS/Utility Settings

1. COM2 RS232/485/422 Setting

Function	JP5	JP4
▲RS232	<pre> 1 3 5 7 9 ■ ■ ■ ■ ■ 2 4 6 8 10 </pre>	<pre> 1 3 5 7 9 11 ■ □ □ □ □ □ 2 4 6 8 10 12 </pre>
RS485	<pre> 1 3 5 7 9 □ □ □ ■ □ 2 4 6 8 10 </pre>	<pre> 1 3 5 7 9 11 □ ■ □ □ □ □ 2 4 6 8 10 12 </pre>
RS422	<pre> 1 3 5 7 9 □ □ □ □ ■ 2 4 6 8 10 </pre>	<pre> 1 3 5 7 9 11 □ □ ■ ■ ■ ■ 2 4 6 8 10 12 </pre>



2. Cash Drawer Power Setting

Function	JP19
▲+19V (for +24V Cash Drawer)	<pre> 1 3 ■ □ 2 4 </pre>
+12V	<pre> 1 3 □ ■ 2 4 </pre>

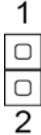

3. Power Mode Setting

Function	JP9
▲ATX Power	<pre> 1 □ 2 </pre>
AT Power	<pre> 1 ■ 2 </pre>

4. System Reset

Function	JP12
▲ System Normal	 1 □ □ 2
System Reset	 1 ■ ■ 2

5. Inverter Selection

Function	JP14
▲ CCFL	 1 □ □ 2
LED	 1 ■ ■ 2



CMOS Operation Mode

CMOS Reset

To clear the CMOS,

1. Remove the power cable from the system.
2. Open the system, and set the 'CMOS Operation jumper' from 'CMOS Normal' to 'CMOS Reset'. (refer to the jumper shown below)
3. Connect the power cable to the system, and **power on the system**:
in ATX mode: press the power button and it will fail power on
in AT mode: turn on system power
4. Remove the power cable from the system.
5. Return the "CMOS Operation mode" jumper setting from "CMOS Reset" to "CMOS normal".
6. Connect the power cable and power on the system.

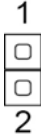
6. CMOS Operation Mode

Function	JP1
▲ CMOS Normal	 1 2
CMOS Reset	 1 2

▲ = Manufacturer Default Setting

Note:



OPEN



SHORT



COM3 & COM4 Power Setting

COM3 and COM4 can be set to provide power to your serial device.

The voltage can be set to +5V or 12V by setting jumper JP18 on the motherboard.

When enabled, the power is available on pin 10 of the RJ45 serial connector.

If you use the serial RJ45 to DB9 adapter cable, the power is on pin 9 of the DB9 connector.

By default, the power option is **disabled** in the BIOS.

Enable COM3/COM4 power in BIOS

1. Power on the system, and press the key when the system is booting up to enter the BIOS Setup utility.
2. Select the Advanced tab
3. Select **Power Configuration COM/VGA Ports** and press <Enter> to go to display the available options.
4. To enable the power, select **COM3 Power Setting** or **COM4 Power setting** and press <Enter>. Select **Power** and press <Enter>. Save the change by pressing F10

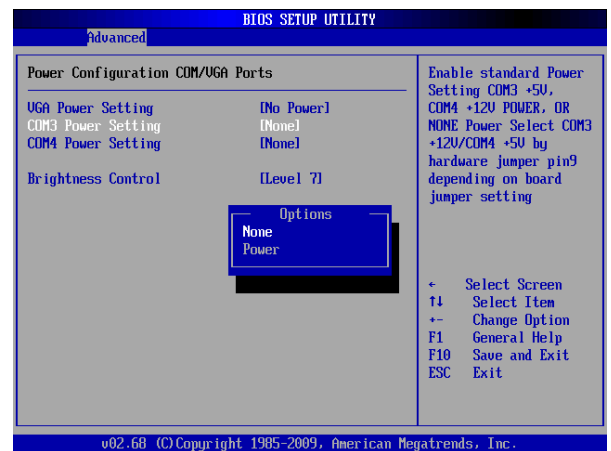

7. COM3/COM4 Power Setting

Function		JP18																
COM3	+5V	<table border="1"> <tr><td>1</td><td>3</td><td>5</td><td>7</td></tr> <tr><td>■</td><td>□</td><td>□</td><td>□</td></tr> <tr><td>■</td><td>□</td><td>□</td><td>□</td></tr> <tr><td>2</td><td>4</td><td>6</td><td>8</td></tr> </table>	1	3	5	7	■	□	□	□	■	□	□	□	2	4	6	8
	1	3	5	7														
■	□	□	□															
■	□	□	□															
2	4	6	8															
▲+12V	<table border="1"> <tr><td>1</td><td>3</td><td>5</td><td>7</td></tr> <tr><td>□</td><td>■</td><td>□</td><td>□</td></tr> <tr><td>□</td><td>■</td><td>□</td><td>□</td></tr> <tr><td>2</td><td>4</td><td>6</td><td>8</td></tr> </table>	1	3	5	7	□	■	□	□	□	■	□	□	2	4	6	8	
1	3	5	7															
□	■	□	□															
□	■	□	□															
2	4	6	8															
COM4	+5V	<table border="1"> <tr><td>1</td><td>3</td><td>5</td><td>7</td></tr> <tr><td>□</td><td>□</td><td>■</td><td>□</td></tr> <tr><td>□</td><td>□</td><td>■</td><td>□</td></tr> <tr><td>2</td><td>4</td><td>6</td><td>8</td></tr> </table>	1	3	5	7	□	□	■	□	□	□	■	□	2	4	6	8
	1	3	5	7														
□	□	■	□															
□	□	■	□															
2	4	6	8															
▲+12V	<table border="1"> <tr><td>1</td><td>3</td><td>5</td><td>7</td></tr> <tr><td>□</td><td>□</td><td>□</td><td>■</td></tr> <tr><td>□</td><td>□</td><td>□</td><td>■</td></tr> <tr><td>2</td><td>4</td><td>6</td><td>8</td></tr> </table>	1	3	5	7	□	□	□	■	□	□	□	■	2	4	6	8	
1	3	5	7															
□	□	□	■															
□	□	□	■															
2	4	6	8															

▲ = Manufacturer Default Setting

Note:



OPEN









SHORT



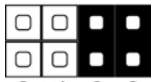



8. LCD ID Setting

Several configurations are applied to different sizes of panel. Please refer to the followings to complete relevant settings.

Resolution			LVDS		Output Interface	JP8
			Bits	Channel		
800	X	600	24	Single	1 st : LCD Panel 2 nd : VGA Port	1 3 5 7  2 4 6 8
1024	x	768	24	Single		1 3 5 7  2 4 6 8
1366	x	768	24	Single		1 3 5 7  2 4 6 8
800	x	600	18	Single		1 3 5 7  2 4 6 8
*800	x	600	18	Single		1 3 5 7  2 4 6 8
1024	x	768	18	Single		1 3 5 7  2 4 6 8

*Note: specialized for Sharp 12.1" LQ121S1LG41/LQ121S1LG42 panel.

▲ = Manufacturer Default Setting

Note:    

OPEN SHORT

2nd VGA Power Setting

VGA port power must be on through BIOS/Utility for default is "No Power"

BIOS/Utility setup

1. Power on the system, and press the key when the system is booting up to enter the BIOS Setup utility.
2. Select the Advanced tab
3. Select "Power Configuration COM/VGA Ports" and press <Enter> to go to display the available options.



4. To switch on the power, select "+12V" press <Enter>. Please Save the change by pressing F10



5. To switch brightness level, select brightness control and choose level. Please save the change before exiting BIOS to avoid data lost.



Appendix A: Drivers Installation

The shipping package includes a Driver CD in which you can find every individual driver and utility that enables you to install the drivers on the system. Please insert the Driver CD into the drive and double click on the “index.htm” to select the models. You can refer to the drivers installation guide for each driver in the “Driver/Manual List”.

Appendix B: OSD Functions for 2nd Display

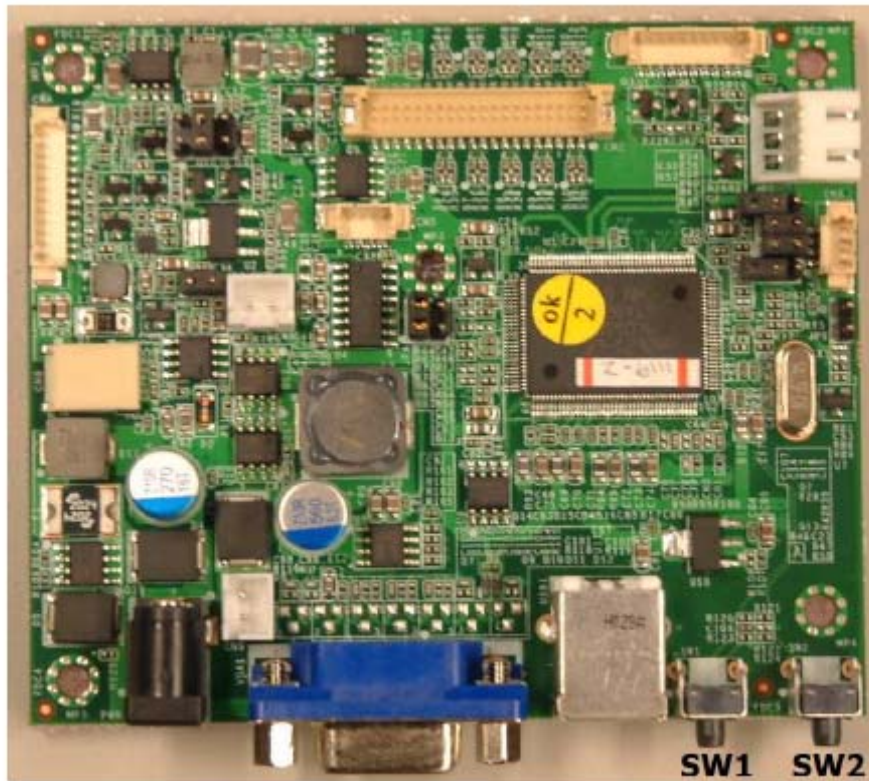

Condition	SW1	SW2	SW1+SW2
Normal Mode (Signal Input Mode)	Power	Auto Tune	Menu Mode (SW1 + SW2 keep press 3 seconds)
Menu Mode	Right	Select	No Function

PS: 2 Key OSD only shifts to right when press SW1 key in menu mode.
 (Ex: Brightness Value: 1→10→1)

1. In the signal input mode, keep pressing the SW1 + SW2 key 3 seconds at the same time.

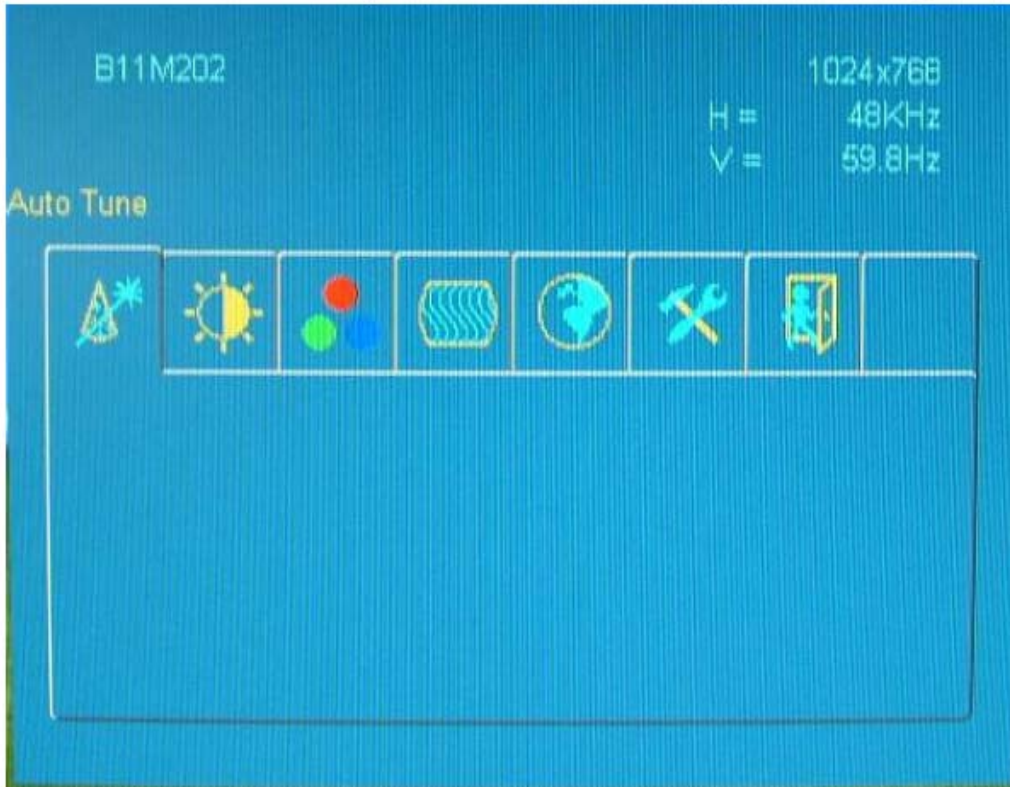

2. Press the SW1 key to select video icon then press the SW2 key to enter brightness adjustment.



3. Press the SW1 key to adjust brightness value.
(Brightness value: 1→2→3→4.....10→1→2.....)

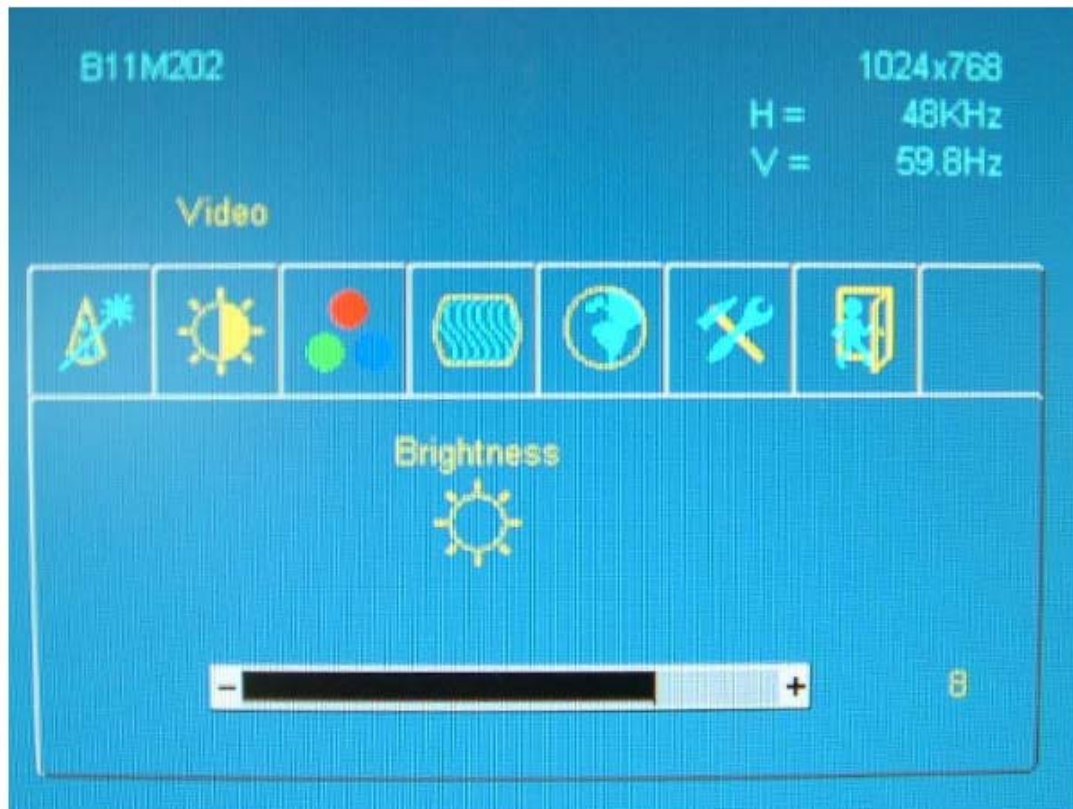

4. Menu mode window will automatically close when there is no command for 10 seconds.

Appendix C: VFD Customer Display

1. Specification

NO	Item	Description
1	Display method	Vacuum fluorescent display
2	Number of character	40 characters (20 columns x 2 lines)
3	Character font	5 x 7 Dot matrix
4	Display color	Blue green
5	Brightness	700 cd /m2
6	Character type	96 alphanumeric 25 kinds of international character set 1 user define character
7	Character size	9.0mm x 5.25mm
8	Power supply	12 ~ 24VDC Manufacture offer +12V power adapter
9	Power consumption	3 ~ 6 W
10	MTBF	25000 hours (power on time)
11	Panel dimensions	224 (W) x 93 (H) x 50(D) mm
12	Support dimensions	Long support : 22 cm Short support : 9 cm
13	Base dimensions	190(w)x55(h)x96(d)mm
14	Viewing angle	-5 ~ 60 degrees
15	Rotation angle	Maximum 270 degrees
16	Weight	1.25 Kg

17	Operating temperature	5 ~ 45°C
18	Operating Humidity	30% ~ 85%
19	Storage Temperature	-10 ~ 55 °C
20	Storage Humidity	10% ~ 85%

2. Interface

Data transmission	Serial
Synchronization	Asynchronous
Signal level	MARK = -3 to -15 V (logic "1") SPACE = +3 to +15 V (logic "0")
Baud rates	4800, 9600, 19200, 38400 bps
Parity	None, even
Bit length	8 bits
Stop bits	1 bit

3. Dip Switch and Software Setting

1.1. Command Type Selection

SW1	SW2	SW3	Command Type	Demo Mode Support	Default
ON	ON	ON	PS7300	No	
OFF	ON	ON	EPSON ESC/POS	Yes	*
ON	OFF	ON	ADM 787/ ADM 788	No	
OFF	OFF	ON	DSP800	Yes	
ON	ON	OFF	AEDEX/ EMAX	No	
OFF	ON	OFF	UTC/P	No	
ON	OFF	OFF	UTC/S	No	
OFF	OFF	OFF	CD5220	Yes	

1.2. Baud Rate Selection

SW8	SW9	Baud Rate (bps)	Default
ON	ON	4800	
OFF	ON	9600	*
ON	OFF	19200	
OFF	OFF	38400	

1.3. Parity Check Selection

SW10	Parity Check	Default
ON	None-parity	*
OFF	Even-parity	

1.4. Command Control

SW12	Function
ON	Depends on SW1~SW11 setting
OFF	Bypass SW1~SW11 setting, fixed at: <ul style="list-style-type: none"><li data-bbox="400 365 847 405">➤ Command type: POS7300,<li data-bbox="400 412 692 452">➤ Baud rate: 9600<li data-bbox="400 459 823 499">➤ Parity check: None-parity<li data-bbox="400 506 762 546">➤ Demo mode: Disable

1.5. International Character Set

ID	SW 4	SW 5	SW 6	SW 7	SW 11	Character Set (20h – 7Fh)	Code Table (80H-FFH)	Default	Note
0	ON	ON	ON	ON	OFF	U.S.A.	CP-437 (USA, Standard Europe)	*	
1	OFF	ON	ON	ON	OFF	FRANCE	CP-858 (Multilingual + Euro Symbol)		
2	ON	OFF	ON	ON	OFF	GERMANY			
3	OFF	OFF	ON	ON	OFF	U.K.			
4	ON	ON	OFF	ON	OFF	DENMARK I			
5	OFF	ON	OFF	ON	OFF	SWEDEN			
6	ON	OFF	OFF	ON	OFF	ITALY			
7	OFF	OFF	OFF	ON	OFF	SPAIN			
8	ON	ON	ON	OFF	OFF	JAPAN	Katakana		
9	OFF	ON	ON	OFF	OFF	NORWAY	CP-858 (Multilingual + Euro Symbol)		
10	ON	OFF	ON	OFF	OFF	DENMARK II			
11	OFF	OFF	ON	OFF	OFF	Slawie			
12	ON	ON	OFF	OFF	OFF	RUSSIA			
13	OFF	ON	OFF	OFF	OFF	U.S.A.	CP-860 (Portuguese)		
14	ON	OFF	OFF	OFF	OFF	U.K.	Greek		
15	OFF	OFF	OFF	OFF	OFF	U.S.A.	CP-852 (Hungary)		
16	ON	ON	ON	ON	ON	U.S.A.	CP-862 (Hebrew)		
17	OFF	ON	ON	ON	ON	U.S.A.	CP-863 (Canadian-French)		
18	ON	OFF	ON	ON	ON	U.S.A.	CP-865 (Nordic)		
19	OFF	OFF	ON	ON	ON	U.S.A.	CP-866 (Cyrillic)		
20	ON	ON	OFF	ON	ON	U.S.A.	Windows-1251 (Cyrillic)		
21	OFF	ON	OFF	ON	ON	U.S.A.	Windows-1252 (West European Latin)		
22	ON	OFF	OFF	ON	ON	U.S.A.	Windows-1255 (Hebrew)		
23	OFF	OFF	OFF	ON	ON	U.S.A.	Windows-1257 (Baltic)		
24	ON	ON	ON	OFF	ON	U.S.A.	Windows-1253 (Greek)		
25	OFF	ON	ON	OFF	ON	U.S.A.	Windows-1250 (East European Latin)		

4. Software Status Setting Commands

When the system is powered on, the VFD will read the DIP switches to set the **Command Type**, **Baud Rate**, **Parity**, and **International Character set**. The user can change the settings as follows:

1.6. Baud Rate Setting Command

STX 05 B n	/Change the baud rate setting/	
ETX		
ASCII Format	STX 05 B n ETX	
Dec. Format	[02] [05] [66] n [03]	
Hex. Format	[02h][05h][42h] n	$30h \leq n \leq 33h$
	[0 3 h]	
Description	Change the display communication baud rate. The baud rate setting can be selected from 4800 to 38400.	

n	Baud rate
30h	4800
31h	9600
32h	19200
33h	38400

1.7. Parity Check Setting Command

STX 05 P n ETX	/Change the Parity check setting/	
ASCII Format	STX 05 P n ETX	
Dec. Format	[02] [05] [80] n	
	[0 3]	
Hex. Format	[02h][05h][50h] n	n=30h, 31h
	[0 3 h]	
Description	Change the display communication parity. Set 8 data bit and the parity set for even or non-parity.	

n	Parity check
30h	None-parity
31h	Even-parity

1.8. International Character Set Setting Command

STX 05 S n /Change the international character set/

ETX

ASCII Format STX 05 S n ETX

Dec. Format [02] [05] [83] n [03]

Hex. Format [02h][05h][53h] n $30h \leq n \leq 4Fh$
[0 3 h]

Description Change the display international character font.

n	Character Set (20h – 7Fh)	Code Table (80H-FFH)	Note
30h	U.S.A.	CP-437 (USA, Standard Europe)	
31h	FRANCE	CP-858 (Multilingual + Euro Symbol)	
32h	GERMANY		
33h	U.K.		
34h	DENMARK I		
35h	SWEDEN		
36h	ITALY		
37h	SPAIN		
38h	JAPAN	Katakana	
39h	NORWAY	CP-858	
3Ah	DENMARK II	(Multilingual+ Euro Symbol)	
3Bh	Slawie		
3Ch	RUSSIA		
3Dh	U.S.A.	CP-860 (Portuguese)	
3Eh	U.K.	Greek	
3Fh	U.S.A.	CP-852 (Hungary)	
40h	U.S.A.	CP-862 (Hebrew)	
41h	U.S.A.	CP-863 (Canadian-French)	
42h	U.S.A.	CP-865 (Nordic)	
43h	U.S.A.	CP-866 (Cyrillic)	
44h	U.S.A.	Windows-1251 (Cyrillic)	
45h	U.S.A.	Windows-1252 (West European Latin)	
46h	U.S.A.	Windows-1255 (Hebrew)	
47h	U.S.A.	Windows-1257 (Baltic)	
48h	U.S.A.	Windows-1253 (Greek)	
49h	U.S.A.	Windows-1250 (East European Latin)	

1.9. Command Type Setting Command

STX 05 C n /Change the command type setting/
ETX
 ASCII Format STX 05 C n ETX
 Dec. Format [02] [05] [67] n [03]
 Hex. Format [02h][05h][43h] n 30h ≤ n ≤ 37h
 [0 3 h]
 Description This command will change the command type and initialize the display.
 The display emulation mode is based on DSP800/ ESC/ ADM 787/ POS7300/ AEDEX/ UTC/ CD5220 mode.

n	Command Type	n	Command Type
30h	POS7300	34h	AEDEX
31h	ESC/POS	35h	UTC/P
32h	ADM 787	36h	UTC/S
33h	DSP800	37h	CD5220

1.10. Run Demo message

STX 05 D 08 /Run demo message/
ETX
 ASCII Format STX 05 D 08 ETX
 Dec. Format [02][05][68][08][03]
 Hex. Format [02h][05h][44h][08h][03h]
 Description Run demo message for the display.
 The display emulation mode is based on DSP800, EPSON ESC/POS, CD5220 command type.

1.11. Show Firmware Version

STX 05 V 01 /Show Firmware Version/
ETX
 ASCII Format STX 05 V 01 ETX
 Dec. Format [02][05][86][01][03]
 Hex. Format [02h][05h][56h][01h][03h]
 Description Show firmware version.

5. Command List Table

Command List Table – 1

	POS7300	CD5220	EPSON D101	UTC/S	UTC/P	AEDEX	ADM788	DSP800
Move cursor right	○	○	○					
Move cursor left	○	○	○					
Move cursor up	○	○	○					
Move cursor down	○	○	○					
Move cursor to right-most position	○	○	○					
Move cursor to left-most position	○	○	○					
Move cursor to home position	○	○	○					
Move cursor to bottom position		○	○					
Move cursor to specified position	○	○	○					○
Clear display screen	○	○	○	○			○	
Clear cursor line	○	○	○					
Brightness adjustment		○	○					○
Blink display screen	○	○	○					○
Initialize display	○	○	○					○
Select character code table		○	○					
Select international character set		○	○					○
Select/cancel reverse character			○					
Overwrite mode	○	○	○	○				
Vertical scroll mode	○	○	○	○				
Horizontal scroll mode	○	○	○					
Set/cancel the window range		○	○					
Select peripheral device		○	○					○
Set starting/ending position of macro definition			○					
Execute and quit macro			○					
Execute self-test		○	○					○
Display time			○		○	○		
Display time continuously			○					
Display position				○				

	POS7300	CD5220	EPSON D101	UTC/S	UTC/P	AEDEX	ADM788	DSP800
Cursor on/off	○	○	○	○				
Change to UTC enhanced mode				○				
Change to UTC standard mode					○			
Write string to upper line	○	○			○	○		

Command List Table – 2

	POS7300	CD5220	EPSON D101	UTC/S	UTC/P	AEDEX	ADM788	DSP800
Upper line message continuous scroll	○	○			○	○		
Bottom line message scroll continuously	○							
Message vertical down scroll continuously	○							
Message vertical upper scroll continuously	○							
Carriage return	○			○			○	
Line feed	○			○				
Back space	○			○				
Horizontal tab	○			○				
Command type select		○	○					○
Upper line message scroll once pass					○	○		
Change attention code					○	○		
Two line display					○	○		
Clear upper line and move cursor to upper left-end position							○	
Clear bottom line and move cursor to bottom left-end position							○	
Set period to upper line, last n position							○	
Set line blinking, upper line	○						○	
Clear line blinking, upper line	○						○	

	POS7300	CD5220	EPSON D101	UTC/S	UTC/P	AEDEX	ADM788	DSP800
Clear field 1 and move cursor to field 1, first position							○	
Clear field 2 and move cursor to field 2,first position							○	
Clear display range from n position to m position and move cursor to n position								○
Save the current displaying data to n layer for demo display								○
Turn annunciator on/off			○					
Specify period			○					
Specify comma			○					
Specify semicolon (period + comma)			○					

6. Command Details

6.1. POS7300 Series Command List

POS7300 Standard Mode Command List-1

Command	Code (hex)	Function Description
ESC F A [DATA] CR	1B 46 41 [DATA] 0D	Write string to upper line ➤ Maximal [DATA] length is 40
ESC F B [DATA] CR	1B 46 42 [DATA] 0D	Write string to lower line ➤ Maximal [DATA] length is 40
ESC F D [DATA] CR	1B 46 44 [DATA] 0D	Upper line message scroll continuously ➤ Maximal [DATA] length is 40
ESC F O [DATA] CR	1B 46 4F [DATA] 0D	Bottom line message scroll continuously ➤ Maximal [DATA] length is 40
ESC P x y	1B 50 x y	Move cursor to specified position ➤ x = 1 ~ 14h, for columns location. ➤ y = 1 ~ 2, for lines location.
ESC _ n	1B 5F n	Set cursor on/off ➤ n = 00 ~ 01
ESC DC1	1B 11	Overwrite mode
ESC DC2	1B 12	Vertical scroll mode
ESC DC3	1B 13	Horizontal scroll mode
ESC @	1B 40	Initialize display
US MD1 n	1F 01 n	Message vertical upper scroll continuously ➤ n = 01 ~ 0Ch
US MD2 n	1F 02 n	Message vertical down scroll continuously ➤ n = 01 ~ 0Ch
US DC1 n	1F 11 n	Set line blinking ➤ n = '1' ~ '2' ■ n = '1' up line ■ n = '2' low line
US DC2 n	1F 12 n	Clear line blinking ➤ n = '1' ~ '2' ■ n = '1' up line ■ n = '2' low line
US E n	1F 45 n	Blink display screen ➤ n = 00h ~ FFh ■ n = 0 for no blink

Command	Code (hex)	Function Description
NULL H	0 48	Move cursor up
NULL K	0 4B	Move cursor left
NULL M	0 4D	Move cursor right
NULL P	0 50	Move cursor down
NULL G	0 47	Move cursor to left-most position
NULL O	0 4F	Move cursor to right-most position

POS7300 Standard Mode Command List-2

Command	Code (hex)	Function Description
BS	08	Back space
HT	09	Horizontal tab
LF	0A	Line feed
HOM	0B	Move cursor to home position
CLR	0C	Clear display screen
CLR	12	Clear display screen
CR	0D	Carriage return
CAN	18	Clear cursor line, and clear string mode
DLE n	10 n	Display position ➤ n = 0 ~ 27h, for location.
ESC = n	1B 3D n	Select peripheral device, display or printer ➤ n = 1~3 ■ n = '1': enable printer only ■ n = '2': enable display only ■ n = '3': enable both of printer and display

6.2. CD5220 Standard Mode Command List

CD5220 Standard Mode Command List-1

Command	Code (hex)	Function Description
ESC DC1	1B 11	Overwrite mode
US SOH	1F 01	
ESC DC2	1B 12	Vertical scroll mode
US STX	1F 02	
ESC DC3	1B 13	Horizontal scroll mode
US ETX	1F 03	
ESC Q A [DATA] CR	1B 51 41 [DATA] 0D	Set the string display mode, write string to upper line. *1 ➤ Maximal [DATA] length is 20
ESC Q B [DATA] CR	1B 51 42 [DATA] 0D	Set the string display mode, write string to lower line. *1 ➤ Maximal [DATA] length is 20
ESC Q D [DATA] CR	1B 51 44 [DATA] 0D	Upper line message scroll continuously. *1 *2 ➤ Maximal [DATA] length is 40
ESD [D	1B 5B 44	Move cursor left
BS	08	
ESC [C	1B 5B 43	Move cursor right
HT	09	
ESC [A	1B 5B 41	Move cursor up
US LF	1F 0A	
ESC [B	1B 5B 42	Move cursor down
LF	0A	
ESC [H	1B 5B 48	Move cursor to home position
HOM	0B	
ESC [L	1B 5B 4C	Move cursor to left-most position
CR	0D	
ESC [R	1B 5B 52	Move cursor to right-most position
US CR	1F 0D	
ESC [K	1B 5B 4B	Move cursor to bottom position
US B	1F 42	
ESC # n	1B 23 n	Command type select ➤ n = 30h ~ 37h
US @	1F 40	Execute self test
US E n	1F 45 n	Blink display screen

Command	Code (hex)	Function Description
		<ul style="list-style-type: none"> ➤ n = 00h ~ FFh ■ n = 0 for no blink
ESC I x y	1B 6C x y	Move cursor to specified position
US \$ x y	1F 24 x y	<ul style="list-style-type: none"> ➤ x = 1 ~ 14h, for columns location. ➤ y = 1,2, for lines location.
ESC @	1B 40	Initialize display

CD5220 Standard Mode Command List-2

Command	Code (hex)	Function Description
ESC W s x1 x2 y	1B 57 s x1 x2 y	<p>Set or cancel the window range at horizontal scroll mode</p> <ul style="list-style-type: none"> ➤ $1 \leq x1 \leq x2 \leq 14h$, for columns location. ➤ y = 1~2, for lines location. ➤ s = 0: cancel ➤ s = 1: set
CLR	0C	Clear display screen, and clear string mode
CAN	18	Clear cursor line, and clear string mode
ESC * n	1B 2A n	Brightness adjustment
US X n	1F 58 n	<ul style="list-style-type: none"> ➤ n = 1 ~ 4, n = 4 for highest brightness
ESC _ n	1B 5F n	<p>Set cursor on/off</p> <ul style="list-style-type: none"> ➤ n = 1: cursor on ➤ n = 0: cursor off
ESC f n	1B 66 n	<p>Select international fonts</p> <ul style="list-style-type: none"> ➤ About n, refer. ^{*3}
ESC c n	1B 63 n	<p>Select fonts, ASCII code or JIS code,</p> <ul style="list-style-type: none"> ➤ About n, refer. ^{*4}
ESC = n	1B 3D n	<p>Select peripheral device, display or printer</p> <ul style="list-style-type: none"> ➤ n='1': enable printer only ➤ n='2': enable display only ➤ n='3': enable both of printer and display

Note:

1. While using command “ESC Q A” or “ESC Q B”, other commands cannot be used except when using command “CLR” or “CAN” to change operating mode.
2. When using command “ESC Q D”, the upper line message will scroll continuously until a new command is received, it will then clear the upper line and move the cursor to the upper left-end position.
3. Select the international Character set (20h – 7Fh) by command “ESC f n”.

Parameter “n”		International Character Set	Parameter “n”		International Character Set
Character	Hex		Character	Hex	
‘A’	41h	U.S.A.	‘W’	57h	Sweden
‘G’	47h	Germany	‘D’	44h	Denmark I
‘I’	49h	Italy	‘E’	45h	Denmark II
‘J’	4Ah	Japan	‘L’	4Ch	Slavonic
‘U’	55h	U.K.	‘R’	52h	Russia
‘F’	46h	France			
‘S’	53h	Spain			
‘N’	4Eh	Norway			

4. Select character code table (80H-FFH) by command “ESC c n”.

Parameter “n”		character Code Table
Character	Hex	
‘A’	41h	Compliance with ASCII code (CP-437)
‘J’	4Ah	Compliance with JIS code (Katakana)
‘L’	4Ch	Compliance with Slawie code
‘R’	52h	Compliance with RUSSIA code
‘M’	4Dh	CP-850 (Multilingual)
‘P’	50h	CP-858 (Multilingual+ Euro Symbol)
‘p’	70h	CP-860 (Portuguese)
‘F’	46h	CP-863 (Canadian-French)
‘N’	4Eh	CP-865 (Nordic)
‘u’	75h	CP-852 (Hungary)
‘H’	48h	CP-862 (Hebrew)
‘C’	43h	CP-866 (Cyrillic)
‘G’	47h	Greek
‘c’	63h	Windows-1251 (Cyrillic)
‘W’	57h	Windows-1252 (West European Latin)
‘h’	68h	Windows-1255 (Hebrew)
‘B’	42h	Windows-1257 (Baltic)
‘g’	67h	Windows-1253 (Greek)

Parameter “n”		character Code Table
Character	Hex	
‘E’	45h	Windows-1250 (East European Latin)

6.3. UTC Standard Mode Command List

Command	Code (hex)	Function Description
BS	08	Back space
HT	09	Horizontal tab
LF	0A	Line feed
CR	0D	Carriage return
DLE n	10 n	Display position ➤ n = 0 ~ 27h, for location.
DC1	11	Over write display mode
DC2	12	Vertical scroll mode
DC3	13	Cursor on
DC4	14	Cursor off
US	1F	Clear display
ESC d	1B 64	Change to UTC enhanced mode

6.4. UTC Enhanced Mode Command List

Command	Code (hex)	Function Description
ESC u A [DATA] CR	1B 75 41 [DATA] 0D	Upper line display ➤ Maximal [DATA] length is 20
ESC u B [DATA] CR	1B 75 42 [DATA] 0D	Bottom line display ➤ Maximal [DATA] length is 20
ESC u D [DATA] CR	1B 75 44 [DATA] 0D	Upper line message scroll continuously ➤ Maximal [DATA] length is 40
ESC u E h h : m m CR	1B 75 45 h h ':' m m 0D	Display time ➤ h, m = '0' ~ '9'
ESC u F [DATA] CR	1B 75 46 [DATA] 0D	Upper line message scroll Once pass ➤ Maximal [DATA] length is 40
ESC u H n m CR	1B 75 48 n m 0D	Change attention code ➤ n = 1 ~ 20h ➤ m = 1 ~ 20h
ESC u I [DATA] CR	1B 75 49 [DATA] 0D	Two line display ➤ Maximal [DATA] length is 40
ESC RS CR	1B 0F 0D	Change to UTC standard mode

6.5. AEDEX/EMAX Mode Command List

Command	Code (hex)	Function Description
! # 4 [DATA] CR	21 23 34 [DATA] 0D	Upper line message scroll ➤ Maximal [DATA] length is 40
! # 5 h h : m m CR	21 23 35 h h ':' m m 0D	Display time ➤ h, m = '0' ~ '9'
! # 8 n m CR	21 23 38 n m 0D	Change attention code ➤ n, m = 1 ~ 20
! # 9 [DATA] CR	21 23 39 [DATA] 0D	Two line display ➤ Maximal [DATA] length is 40
! # 6 [DATA] CR	21 23 36 [DATA] 0D	Upper line message scroll once pass ➤ Maximal [DATA] length is 40

6.6. ADM787/788 mode command list

Command	Code (hex)	Function Description
CLR	0C	Clear display
CR	0D	Carriage return
SLE1	0E	Clear upper line and move cursor to upper left-end position
SLE2	0F	Clear bottom line and move, Cursor to bottom left-end position
DC0 n	10 n	Set period to upper line last n position ➤ n = 31H ~ 37H
DC1 n	11 n	Set line blinking, upper line ➤ n = '1' ~ '2' ■ n = '1': up line ■ n = '2': low line
DC2 n	12 n	Clear line blinking, upper line ➤ n = '1' ~ '2' ■ n = '1': up line ■ n = '2': low line
SF1	1E	Clear field 1 and move cursor to field 1, first position
SF2	1F	Clear field 2 and move cursor to field 2, first position

6.7. DSP800 Mode Command List

Command	Code (hex)	Function Description
EOT SOH I n ETB	04 01 49 n 17	Select international character set ➤ n = 00 ~ 0Fh or 30 ~ 3Fh
EOT SOH P n ETB	04 01 50 n 17	Move cursor to specified position ➤ n = 31h ~ 58h
EOT SOH C n m ETB	04 01 43 n m 17	Clear display range from <u>n</u> position to <u>m</u> position and move cursor to <u>n</u> position ➤ $31h \leq n \leq m \leq 58h$
EOT SOH S n ETB	04 01 53 n 17	Save current view message to n layer for demo view data ➤ n = 31h ~ 35h
EOT SOH D n m ETB	04 01 44 n m 17	Display the saved demo message ➤ n = 31h ~ 4Fh ➤ m = 31h ~ 33h
EOT SOH A n ETB	04 01 41 n 17 n = 31h-34h	Brightness adjustment
EOT SOH F n ETB	04 01 46 n 17 $00h \leq n \leq FFh$	Blink display Screen ➤ n = 00h ~ FFh, n = 0 for no blink
EOT SOH # n ETB	04 01 23 n 17 n = 30~37h	Command type select
EOT SOH % ETB	04 01 25 17	Initialize display
EOT SOH @ ETB	04 01 40 17	Execute self-test
EOT SOH = n ETB	04 01 3D n 17	Select peripheral device, display or printer ➤ n = '1': enable printer only n = '2': enable display only n = '3': enable both of printer and display

6.8. EPSON ESC/POS Command List

EPSON ESC/POS Command List-1

Command	Code (hex)	Function Description
US r n	1F 72 n	Select/cancel reverse character. ➤ n = 00,01
US MD1	1F 01	Specify overwrite mode.
US MD2	1F 02	Specify vertical scroll mode.
US MD3	1F 03	Specify horizontal scroll mode.
CAN	18	Clear cursor line
ESC # n	1B 23 n	Command type select ➤ n = 30h ~ 37h
US # n x	1F 23 n x	Turn annunciator on/off. ➤ n = 0 for annunciator off n = 1 for annunciator on ➤ x = 1 ~ 14h, for columns location.
US C n	1F 43 n	Set cursor on/off ➤ n = 00, 01
BS	08	Move cursor left
HT	09	Move cursor right
US LF	1F 0A	Move cursor up
LF	0A	Move cursor down
US CR	1F 0D	Move cursor to right-most position
CR	0D	Move cursor to left-most position
HOM	0B	Move cursor to home position
US B	1F 42	Move cursor to bottom position
US \$ x y	1F 24 x y	Move cursor to specified position ➤ x = 1 ~ 14h, for columns location. ➤ y = 1 ~ 2, for lines location.
CLR	0C	Clear display screen
US E n	1F 45 n	Blink display screen ➤ n = 00h ~ FFh n = 0 for no blink
ESC @	1B 40	Initialize display
US . n	1F 2E n	Specify period ➤ n = a displayable character code
US , n	1F 2C n	Specify comma ➤ n = a displayable character code
US ; n	1F 3B n	Specify semicolon (period + comma)

Command	Code (hex)	Function Description
		➤ n = a displayable character code
US :	1F 3A	Set starting/ending position of macro definition. Ex.: 1F 3A ... (macro string) ... 1F 3A
US @	1F 40	Execute self - test
US T h m	1F 54 h m	Display time ➤ $0 \leq h \leq 17h$, for hours setting. ➤ $0 \leq m \leq 3Bh$, for minutes setting.

EPSON ESC/POS Command List-2

Command	Code (hex)	Function Description
US ^ n m	1F 5E n m	Execute and quit macro. It's an interval of n between the two words. It's an interval of m between the two strings. ➤ $00 \leq (n, m) \leq FFh$ ■ n = Word time ■ m = show string time
US U	1F 55	Display time continuously
US X n	1F 58 n	Brightness adjustment ➤ n = 1 ~ 4
ESC W n s x1 y1 x2 y2	1B 57 n s x1 y1 x2 y2	Set or cancel the window range ➤ n = 1 ~ 4, for window number ➤ s = 0: cancel s = 1: set ➤ $1 \leq x1 \leq x2 \leq 14h$, for columns location. ➤ $1 \leq y1 \leq y2 \leq 2$, for lines location.
ESC R n	1B 52 n	Select international character set (20H~7Fh). ➤ n = 00 ~ 0Fh. See note *1
ESC t n	1B 74 n	Select character code table (80H~FFh). ➤ n = 00 ~ 1Fh. See note *2
ESC = n	1B 3D n	Select peripheral device, display or printer ➤ n = '1': enable printer only n = '2': enable display only n = '3': enable both of printer and display

Note:

1. Select international character set (20H~7Fh) by command "ESC R n"

n	International character set	n	International character set	n	International character set
0h	U.S.A.	6h	ITALY	Ch	RUSSIA
1h	FRANCE	7h	SPAIN	Dh	Not used
2h	GERMANY	8h	JAPAN	Eh	Not used
3h	U.K.	9h	NORWAY	Fh	Not used
4h	DENMARK I	Ah	DENMARK II		
5h	SWEDEN	Bh	SLAVONIC		

2. Select character code table (80H~FFh) by command “ESC t n”

n	Character code table	n	Character code table	n	Character code table
0h	CP-437 (USA, Standard Europe)	7h	Russia	Fh	Windows-1257 (Baltic)
1h	Katakana (for Japan)	8h	Greek	10h	Windows-1252 (West European Latin)
2h	CP-850 (Multilingual)	9h	CP-852 (Hungary)	11h	Windows-1253 (Greek)
3h	CP-860 (Portuguese)	Ah	CP-862 (Hebrew)	12h	Windows-1250 (East European Latin)
4h	CP-863 (Canadian-French)	Bh	CP-866 (Cyrillic)	13h	CP-858 (Multilingual+ Euro Symbol)
5h	CP-865 (Nordic)	Ch	Windows-1251 (Cyrillic)		
6h	Slawie	Eh	Windows-1255 (Hebrew)		

7. Character Set

7.1. Character Code 20H – 7FH

7.1.1. International Character Sets

Character Code Number													
Country	Hex	23	24	40	5B	5C	5D	5E	60	7B	7C	7D	7E
	Dec	35	36	64	91	92	93	94	96	123	124	125	126
U.S.A	#	\$	@	[\]	^	`	{		}	~	
France	#	\$	à	°	ç	§	^	`	é	ù	è	¨	
Germany	#	\$	§	Ä	Ö	Ü	^	`	ä	ö	ü	ß	
U.K	£	\$	@	[\]	^	`	{		}	~	
Denmark I	#	\$	@	Æ	Ø	Å	^	`	æ	ø	å	~	
Sweden	#	α	É	Ä	Ö	Å	Ü	é	ä	ö	å	ü	
Italy	#	\$	@	°	\	é	^	ù	à	ò	è	ì	
Spain	Pt	\$	@	ı	Ñ	¿	^	`	¨	ñ	}	~	
Japan	#	\$	@	[¥]	^	`	{		}	~	
Norway	#	α	É	Æ	Ø	Å	Ü	é	æ	ø	å	ü	
Denmark II	#	\$	É	Æ	Ø	Å	Ü	é	æ	ø	å	ü	
Slavonic	#	\$	@	[\]	^	`	{		}	~	
Russia	#	\$	@	[\]	^	`	{		}	~	

7.1.2. USA, Standard Character Sets

	00h	01h	02h	03h	04h	05h	06h	07h	08h	09h	0Ah	0Bh	0Ch	0Dh	0Eh	0Fh
20h		!	“	#	\$	%	&	‘	()	*	+	,	-	.	/
30h	0	1	2	3	4	5	6	7	8	9	:	;	<	=	>	?
40h	@	A	B	C	D	E	F	G	H	I	J	K	L	M	N	O
50h	P	Q	R	S	T	U	V	W	X	Y	Z	[\]	^	_
60h	`	a	b	c	d	e	f	g	h	i	j	k	l	m	n	o
70h	p	q	r	s	t	u	v	w	x	y	Z	{		}	~	

7.2. Character Code 80H – FFH

7.2.1. CP-437 (USA, Standard Europe)

	00h	01h	02h	03h	04h	05h	06h	07h	08h	09h	0Ah	0Bh	0Ch	0Dh	0Eh	0Fh
80h	Ç	ü	é	â	ä	à	å	ç	ê	ë	è	ï	î	ì	Ä	Å
90h	É	æ	Æ	ô	ö	ò	û	ù	ÿ	Ö	Ü	ø	£	¥	Pt	f
A0h	á	í	ó	ú	ñ	Ñ	ª	º	¿	¬	¬	½	¼	¡	«	»
B0h	⌘	⌘	⌘		†	‡	‡	π	ƒ	‡		¶	¶	¶	¶	¶
C0h	L	⊥	⊥	†	—	†	‡	‡	ℒ	ℒ	⊥	¶	¶	=	‡	⊥
D0h	⊥	¶	π	ℒ	ℒ	ƒ	π	‡	‡	∟	∟	■	■	■	■	■
E0h	α	β	Γ	π	Σ	σ	μ	τ	Φ	θ	Ω	δ	∞	∅	ε	∩
F0h	≡	±	≥	≤	∫	∫	÷	≈	°	•	•	√	n	2	■	

7.2.2. CP-850 (Multilingual)

	00h	01h	02h	03h	04h	05h	06h	07h	08h	09h	0Ah	0Bh	0Ch	0Dh	0Eh	0Fh
80h	Ç	ü	é	â	ä	à	å	ç	ê	ë	è	ï	î	ì	Ä	Å
90h	É	æ	Æ	ô	ö	ò	û	ù	ÿ	ö	Ü	ø	£	Ø	×	f
A0h	á	í	ó	ú	ñ	Ñ	á	â	ç	®	¬	½	¼	ì	«	»
B0h	☒	☒	☒		†	Á	Â	À	©	¶		¶	¶	¢	¥	⌞
C0h	L	⊥	⊥	†	—	†	ã	Ã	ℒ	¶	⊥	¶	¶	=	¶	α
D0h	ö	Ð	Ê	Ë	È	l	í	î	ï	⌞	⌞	■	■	ì	ì	■
E0h	ó	ß	ô	ò	õ	Õ	μ	þ	Ɔ	Ú	Û	Ù	ý	Ý	—	´
F0h	—	±	=	¾	¶	§	÷	˘	°	¨	·	1	3	2	■	

7.2.3. CP-858 (Multilingual + Euro Symbol)

	00h	01h	02h	03h	04h	05h	06h	07h	08h	09h	0Ah	0Bh	0Ch	0Dh	0Eh	0Fh
80h	Ç	ü	é	â	ä	à	å	ç	ê	ë	è	ï	î	ì	Ä	Å
90h	É	æ	Æ	ô	ö	ò	û	ù	ÿ	ö	Ü	ø	£	Ø	×	f
A0h	á	í	ó	ú	ñ	Ñ	á	â	ç	®	¬	½	¼	ì	«	»
B0h	☒	☒	☒		†	Á	Â	À	©	¶		¶	¶	¢	¥	⌞
C0h	L	⊥	⊥	†	—	†	ã	Ã	ℒ	¶	⊥	¶	¶	=	¶	α
D0h	ö	Ð	Ê	Ë	È	€	í	î	ï	⌞	⌞	■	■	ì	ì	■
E0h	ó	ß	ô	ò	õ	Õ	μ	þ	Ɔ	Ú	Û	Ù	ý	Ý	—	´
F0h	—	±	=	¾	¶	§	÷	˘	°	¨	·	1	3	2	■	

7.2.4. Katakana for Japan

	00h	01h	02h	03h	04h	05h	06h	07h	08h	09h	0Ah	0Bh	0Ch	0Dh	0Eh	0Fh	
80h	α	β	γ	△	ε	η	θ	λ	μ	π	ρ	σ	τ	Φ	Ω	Σ	
90h	£	§	IE	IR	∫	̄x	Ā	⁻¹	²	³	x	½	1/	√	±	■	
A0h		。	「	」	、	・	ヲ	フ	イ	ウ	エ	オ	ヤ	ユ	ヨ	ツ	
B0h	一	ア	イ	ウ	エ	オ	カ	キ	ク	ケ	コ	サ	シ	ス	セ	ソ	
C0h	タ	チ	ツ	テ	ト	ナ	ニ	ヌ	ネ	ノ	ハ	ヒ	フ	ヘ	ホ	マ	
D0h	ミ	ム	メ	モ	ヤ	ユ	ヨ	ラ	リ	ル	レ	ロ	ワ	ン	"	°	
E0h	↑	↓	←	→	↶	↷	↸	↹	↺	↻	↷	↸	↹	↺	↻	∴	∴
F0h	≤	≥	≠	≡	∥		⊥	∞	α	~	~	≡	≡	⊕	⊕	⊖	

7.2.5. Slawie

	00h	01h	02h	03h	04h	05h	06h	07h	08h	09h	0Ah	0Bh	0Ch	0Dh	0Eh	0Fh
80h	Ç	ü	é	â	ä	û	ć	ç	ł	ë	õ	õ	î	ż	ä	ć
90h	é	ł	í	ô	ö	ł	ĩ	ś	ś	Ö	Ü	ł	ł	ł	x	č
A0h	á	í	ó	ú	ą	ą	ż	ż	ę	ę		ż	č	§	«	»
B0h	☐	☐	☐		†	á	â	ě	ş					ł	ł	
C0h					—	†	ă	ă						=		α
D0h	đ	đ	d'	ë	d'	ň	í	î	ě			■	■	ł	û	■
E0h	ó	β	ô	ń	ń	ň	š	š	ř	ú	ř	ũ	ý	ý	ł	'
F0h	—	~	,	ˇ	ˇ	§	÷	˘	°	¨	·	ũ	ř	ř	■	

7.2.6. Russia

	00h	01h	02h	03h	04h	05h	06h	07h	08h	09h	0Ah	0Bh	0Ch	0Dh	0Eh	0Fh
80h	А	Б	В	Г	Д	Е	Ж	З	И	Й	К	Л	М	Н	О	П
90h	Р	С	Т	У	Ф	Х	Ц	Ч	Ш	Щ	Ъ	Ы	Ь	Э	Ю	Я
A0h	а	б	в	г	д	е	ж	з	и	й	к	л	м	н	о	п
B0h																
C0h																
D0h																
E0h	р	с	т	у	ф	х	ц	ч	ш	щ	ъ	ы	ь	э	ю	я
F0h	ѐ	ґ	ҕ	ҕ	ѐ	ҕ	ҕ	ҕ	ѐ	ґ	ҕ	ҕ	ѐ	ҕ	ҕ	

7.2.7. CP-860 (Portuguese)

	00h	01h	02h	03h	04h	05h	06h	07h	08h	09h	0Ah	0Bh	0Ch	0Dh	0Eh	0Fh
80h	Ç	ü	é	â	ã	à	Á	ç	ê	Ê	è	í	Ô	ì	Ã	Â
90h	É	À	È	ô	õ	ò	Ú	ù	ì	Õ	Ü	ç	£	Ù	Þ	Ó
A0h	á	í	ó	ú	ñ	Ñ	ã	o	ç	Ò	¬	½	¼	¡	«	»
B0h	⌘	⌘	⌘		†	‡	‡	π	¶	¶		¶	¶	¶	¶	¶
C0h	L	⊥	⊥	†	—	†	‡	‡	ℒ	¶	¶	¶	¶	=	¶	±
D0h	¶	¶	¶	ℒ	ℒ	¶	¶	¶	¶	¶	ℒ	■	■	■	■	■
E0h	α	β	Γ	π	Σ	σ	μ	τ	Φ	θ	Ω	δ	∞	∅	ε	∩
F0h	≡	±	≥	≤		J	÷	≈	°	•	·	√	n	2	■	

7.2.8. Greek

	00h	01h	02h	03h	04h	05h	06h	07h	08h	09h	0Ah	0Bh	0Ch	0Dh	0Eh	0Fh
80h	Α	Β	Γ	Δ	Ε	Ζ	Η	Θ	Ι	Κ	Λ	Μ	Ν	Ξ	Ο	Π
90h	Ρ	Σ	Τ	Υ	Φ	Χ	Ψ	Ω	α	β	γ	δ	ε	ζ	η	θ
A0h	ι	κ	λ	μ	ν	ξ	ο	π	ρ	σ	ς	τ	υ	φ	χ	ψ
B0h																
C0h																
D0h																
E0h	ω															
F0h										£				-		

7.2.9. CP-852 (Hungary)

	00h	01h	02h	03h	04h	05h	06h	07h	08h	09h	0Ah	0Bh	0Ch	0Dh	0Eh	0Fh
80h	Ç	ü	é	â	ä	û	ó	ç	ł	ë	Ő	ó	î	Ž	Ä	Ć
90h	É	Í	í	ô	ö	Ĺ	ı	Ś	ś	Ö	Ü	Ť	ť	Ł	x	č
A0h	á	í	Ó	ú	Ą	ą	Ž	ž	Ę	ę	¬	ż	Č	ş	«	»
B0h	⠠	⠡	⠢		†	Á	Â	Ě	Ş	‡		¶	‡	ž	ž	‡
C0h	Ł	⊥	⊥	†	—	†	Ǻ	ǻ	Ł	Ɔ	⊥	⊥	‡	=	‡	α
D0h	đ	Đ	Ď	Ě	ď	Ň	í	î	ě	┘	г	■	■	‡	Û	■
E0h	Ó	β	Ô	Ń	ń	ň	Š	š	Ŕ	Ú	ř	Ů	ý	Ý	‡	'
F0h	—	~	,	˘	˘	§	÷	˘	°	¨	·	ũ	Ř	ř	■	

7.2.10. CP-862 (Hebrew)

	00h	01h	02h	03h	04h	05h	06h	07h	08h	09h	0Ah	0Bh	0Ch	0Dh	0Eh	0Fh
80h	א	ב	ג	ד	ה	ו	ז	ח	ט	י	ך	כ	ל	מ	נ	ן
90h	ג	ו	ע	ק	פ	צ	ק	ר	ש	ת	ץ	£	¥	Pts	f	
A0h	á	í	ó	ú	ñ	Ñ	ª	º	¿	¬	¬	½	¼	ı	«	»
B0h	⋯	⋯	⋯		┆	≡	≡	π	₯	≡	≡	₯	≡	≡	≡	₯
C0h	L	⊥	T	┆	—	⊕	≡	≡	ℒ	℞	≡	≡	≡	=	≡	⊥
D0h	≡	≡	π	ℒ	℞	℞	π	≡	≡	J	Γ	■	■	■	■	■
E0h	α	β	Γ	π	Σ	σ	μ	τ	Φ	Θ	Ω	δ	∞	φ	ε	∩
F0h	≡	±	≥	≤		J	÷	≈	°	.	.	√	n	²	■	

7.2.11. CP-863 (Canadian- French)

	00h	01h	02h	03h	04h	05h	06h	07h	08h	09h	0Ah	0Bh	0Ch	0Dh	0Eh	0Fh
80h	Ç	ü	é	â	Â	à	¶	ç	ê	ë	è	ï	î	=	Ä	§
90h	É	È	Ê	ô	Ë	Ï	û	ù	œ	Ô	Ü	ç	£	Ù	Û	f
A0h		í	‘	ó	ú	¨	˘	˘	Î	¬	¬	½	¼	¾	«	»
B0h	⋯	⋯	⋯		┆	≡	≡	π	₯	≡	≡	₯	≡	≡	≡	₯
C0h	L	⊥	T	┆	—	⊕	≡	≡	ℒ	℞	≡	≡	≡	=	≡	⊥
D0h	≡	≡	π	ℒ	℞	℞	π	≡	≡	J	Γ	■	■	■	■	■
E0h	α	β	Γ	π	Σ	σ	μ	τ	Φ	Θ	Ω	δ	∞	φ	ε	∩
F0h	≡	±	≥	≤		J	÷	≈	°	.	.	√	n	²	■	

7.2.12. CP-865 (Nordic)

	00h	01h	02h	03h	04h	05h	06h	07h	08h	09h	0Ah	0Bh	0Ch	0Dh	0Eh	0Fh	
80h	Ç	ü	é	â	ä	à	å	ç	ê	ë	è	ï	î	ì	Ä	Å	
90h	É	æ	Æ	ô	ö	ò	û	ù	ÿ	Ö	Ü	ø	£	Ø	Pt	f	
A0h	á	í	ó	ú	ñ	Ñ	ª	º	¿	¬	½	¼	¡	«	»		
B0h	⌘	⌘	⌘		┌	┐	└	┘	┌	┐	└	┘	┌	┐	└	┘	
C0h	L	⊥	⊥	┌	┐	└	┘	┌	┐	└	┘	┌	┐	└	┘	┌	┐
D0h	⌘	⌘	⌘	⌘	⌘	⌘	⌘	⌘	⌘	⌘	■	■	■	■	■		
E0h	α	β	Γ	π	Σ	σ	μ	τ	Φ	θ	Ω	δ	∞	ø	ε	∩	
F0h	≡	±	≥	≤			÷	≈	°	•	·	√	n	²	■		

7.2.13. CP-866 (Cyrillic)

	00h	01h	02h	03h	04h	05h	06h	07h	08h	09h	0Ah	0Bh	0Ch	0Dh	0Eh	0Fh	
80h	А	Б	В	Г	Д	Е	Ж	З	И	Й	К	Л	М	Н	О	П	
90h	Р	С	Т	У	Ф	Х	Ц	Ч	Ш	Щ	Ъ	Ы	Ь	Э	Ю	Я	
A0h	а	б	в	г	д	е	ж	з	и	й	к	л	м	н	о	п	
B0h	⌘	⌘	⌘		┌	┐	└	┘	┌	┐	└	┘	┌	┐	└	┘	
C0h	L	⊥	⊥	┌	┐	└	┘	┌	┐	└	┘	┌	┐	└	┘	┌	┐
D0h	⌘	⌘	⌘	⌘	⌘	⌘	⌘	⌘	⌘	⌘	■	■	■	■	■		
E0h	р	с	т	у	ф	х	ц	ч	ш	щ	ъ	ы	ь	э	ю	я	
F0h	Ё	ё	Є	є	İ	ı	Ÿ	ÿ	°	•	·	√	№	α	■		

7.2.14. Windows-1250

	00h	01h	02h	03h	04h	05h	06h	07h	08h	09h	0Ah	0Bh	0Ch	0Dh	0Eh	0Fh
80h	€		,		„	…	†	‡		‰	Š	<	Š	Ť	Ž	Ž
90h		‘	’	“	”	•	–	—		™	š	>	š	ť	ž	ž
A0h		ˇ	ˇ	ł	α	Α		§	¨	©	š	«	¬		®	ž
B0h	°	±	ı	ł	´	μ	¶	·	¸	ą	ś	»	ł	˝	ı	ż
C0h	Ř	Á	Â	Ǻ	Ä	Í	Ć	Ç	Č	É	Ě	Ě	Ě	Í	Î	Ď
D0h	Đ	Ń	Ň	Ó	Ô	Õ	Ö	×	Ř	Ú	Ú	Ú	Ü	Ý	ı	ß
E0h	ř	á	â	ǻ	ä	í	ć	ç	č	é	ě	ě	ě	í	î	ď
F0h	đ	ń	ň	ó	ô	õ	ö	÷	ř	ú	ú	ú	ü	ý	ı	·

7.2.15. Windows-1251 (Cyrillic)

	00h	01h	02h	03h	04h	05h	06h	07h	08h	09h	0Ah	0Bh	0Ch	0Dh	0Eh	0Fh
80h	Ѡ	Ґ	,	ѓ	„	…	†	‡	€	‰	Љ	<	Њ	Ќ	Ѡ	ѡ
90h	Ѡ	‘	’	“	”	•	–	—		™	љ	>	њ	ќ	ћ	ѡ
A0h		Ў	ў	Ј	α	Ґ		§	Ё	©	Є	«	¬		®	Ї
B0h	°	±	І	і	ѓ	μ	¶	·	ё	№	є	»	ј	ѕ	ѕ	ї
C0h	А	Б	В	Г	Д	Е	Ж	З	И	Й	К	Л	М	Н	О	П
D0h	Р	С	Т	У	Ф	Х	Ц	Ч	Ш	Щ	Ъ	Ы	Ь	Э	Ю	Я
E0h	А	б	в	г	д	е	ж	з	и	й	к	л	м	н	о	п
F0h	Р	с	т	у	ф	х	ц	ч	ш	щ	ъ	ы	ь	э	ю	я

7.2.16. Windows-1252 (West European Latin)

	00h	01h	02h	03h	04h	05h	06h	07h	08h	09h	0Ah	0Bh	0Ch	0Dh	0Eh	0Fh
80h	€		,	f	„	…	†	‡	^	‰	Š	‹	Œ		Ž	
90h		‘	’	“	”	•	–	—	~	™	š	›	œ		ž	ÿ
A0h		ı	ç	£	¤	¥	¦	§	¨	©	ª	«	¬		®	¯
B0h	°	±	²	³	´	µ	¶	·	¸	¹	º	»	¼	½	¾	¿
C0h	À	Á	Â	Ã	Ä	Å	Æ	Ç	È	É	Ê	Ë	Ì	Í	Î	Ï
D0h	Ð	Ñ	Ò	Ó	Ô	Õ	Ö	×	Ø	Ù	Ú	Û	Ü	Ý	Þ	ß
E0h	à	á	â	ã	ä	å	æ	ç	è	é	ê	ë	ì	í	î	ï
F0h	ð	ñ	ò	ó	ô	õ	ö	÷	ø	ù	ú	û	ü	ý	þ	ÿ

7.2.17. Windows-1253 (Greek)

	00h	01h	02h	03h	04h	05h	06h	07h	08h	09h	0Ah	0Bh	0Ch	0Dh	0Eh	0Fh
80h	€		,	f	„	…	†	‡		‰		‹				
90h		‘	’	“	”	•	–	—		™		›				
A0h		ˆ	À	£	¤	¥	¦	§	¨	©		«	¬	–	®	¯
B0h	°	±	²	³	´	µ	¶	·	ˆ	ˆ	ˆ	»	ˆ	½	ˆ	ˆ
C0h	ı	A	B	Γ	Δ	E	Z	H	Θ	I	K	Λ	M	N	Ξ	O
D0h	Π	P		Σ	T	Y	Φ	X	Ψ	Ω	İ	ÿ	ά	έ	ή	ί
E0h	ϖ	α	β	γ	δ	ε	ζ	η	θ	ι	κ	λ	μ	ν	ξ	ο
F0h	π	ρ	ς	σ	τ	υ	φ	χ	ψ	ω	ı	ÿ	ό	ύ	ώ	

7.2.18. Windows-1255 (Hebrew)

	00h	01h	02h	03h	04h	05h	06h	07h	08h	09h	0Ah	0Bh	0Ch	0Dh	0Eh	0Fh
80h	€		,	f	„	…	†	‡	^	‰		<				
90h		‘	’	“	”	•	—	—	~	™		>				
A0h		ı	¢	£	¤	¥	¦	§	¨	©	×	«	¬	–	®	—
B0h	°	±	²	³	´	µ	¶	·	¸	¹	÷	»	¼	½	¾	¿
C0h	:	;	;	:	.	..	ˆ	-	˘	˙		˚	˛	ı	-	-
D0h		·	·	:		ıı	”	’	”	,	:	;	.	!	?	
E0h	א	ב	ג	ד	ה	ו	ז	ח	ט	י	ך	כ	ל	ם	נ	ן
F0h	נ	ס	ע	ף	פ	ץ	צ	ק	ר	ש	ת					

7.2.19. Windows-1257 (Baltic)

	00h	01h	02h	03h	04h	05h	06h	07h	08h	09h	0Ah	0Bh	0Ch	0Dh	0Eh	0Fh
80h	€		,		„	…	†	‡		‰		<		¨	˘	¸
90h		‘	’	“	”	•	—	—		™		>		—	˘	
A0h			¢	£	¤		¦	§	Ø	©	Ŕ	«	¬	–	®	Æ
B0h	°	±	²	³	´	µ	¶	·	ø	¹	ŕ	»	¼	½	¾	æ
C0h	Ą	Į	Ā	Ć	Ä	Å	Ę	Ē	Č	É	Ž	È	Ğ	Ķ	Ī	Ļ
D0h	Š	Ń	Ņ	Ó	Ō	Õ	Ö	×	Ū	Ł	Ś	Ū	Ü	Ž	Ž	ß
E0h	ą	į	ā	ć	ä	å	ę	ē	č	é	ž	è	ğ	ķ	ī	ļ
F0h	š	ń	ņ	ó	ō	õ	ö	÷	ū	ł	ś	ū	ü	ž	ž	·

8. Command Details

A.1. Overwrite mode

In this mode, the cursor will move towards the right and begin from the upper left position. When the cursor has reached the end of the upper line, the cursor will move down to the bottom left position to continue. When the cursor has reached the end of the bottom line, it will move to up the upper left position and overwrite the previous characters.

A.2. Vertical scroll mode

In this mode, the cursor will move towards the right. The cursor will begin from the upper left position until it has reached the end of the upper line. The cursor will then move down to the bottom left position to continue until it has reached the end of the bottom line.

A.3. Horizontal scroll mode

In this mode, the extent of the cursor activity is bound by a predefined range, limited to the upper line. (Please refer to Set or cancel window command), where the default window is the whole upper line. The cursor will begin from the left-end of the range and move rightward until it reached the end of the range, to continue, the characters that comes thereafter will start pushing the previous characters leftward from the right-end, scrolling the characters to the left.

A.4. Set the string display mode and write string to display

Set the string display mode, write to upper or lower line $d_1 d_2 d_3 \dots d_n$ $\{1 \leq n \leq 20\}$. 'A' stands for the upper line, 'B' stands for the lower line. The string display mode will be cancelled and the display will return to the previous mode after receiving CLR or CAN.

A.5. Upper line message continuous scroll

The message (previously defined) will scroll continuously in the horizontal direction until a new command is received.

A.6. Move cursor left

When the current cursor is at the left-end position, this command operates differently depending on the display mode.

- **Overwrite mode:** When the cursor reached the left-end of the lower line, it will continue to the right-end of the upper line, overwrite previous characters. When it reached the left end of the upper line, it will continue to the right-end of the lower line.
- **Vertical scroll mode:** When the cursor reached the left-end of the lower line, the lower line will scroll up and replace the previous upper line, the lower line will be cleared and the cursor will continue to the right end of the lower line.
- **Horizontal scroll mode:** The cursor will remain stationary.

A.7. Move cursor right

Move the cursor to the right. When the cursor has reached the right-end, this command operates differently depending on the display mode.

- **Overwrite mode:** When the cursor has reached the right-end of the lower line, it will continue to the left-end of the upper line and overwrite previous characters. When it has reached the right-end of the upper line, it will continue to the right-end of the lower line.
- **Vertical scroll mode:** When the cursor has reached the right-end of the lower line, the lower line will scroll up to replace the upper line, the lower line is cleared and ready to continue characters thereafter.
- **Horizontal scroll mode:** The cursor will remain stationary.

A.8. Move cursor up

Move the cursor up one line. When the cursor is on the upper line, this command operates differently depending on the display mode.

- **Overwrite mode:** The cursor is moved to the same column the lower line.
- **Vertical scroll mode:** The characters displayed on the upper line is scrolled to the lower line, and the upper line is cleared. The cursor will remain at the same position.
- **Horizontal scroll mode:** The cursor will remain stationary.

A.9. Move cursor down

Move the cursor down one line. When the cursor is on the lower line, this command operates differently depending on the display mode.

- **Overwrite mode:** The cursor is moved to the same column on the upper line.
- **Vertical scroll mode:** The characters displayed on the lower line are scrolled to the upper line, and the lower line is cleared. The cursor will remain at the same position.
- **Horizontal scroll mode:** The cursor will remain stationary.

A.10. Move cursor to home position

The cursor will move to the left-end position of the upper line.

A.11. Move cursor to left-most position

The cursor will be moved to the left-end position of the current line.

A.12. Move cursor to right-most position

The cursor will be moved to the right-end position of the current line.

A.13. Move cursor to bottom position

The cursor will be moved to the right-end position on the lower line.

A.14. Move cursor to specified position

The cursor will be moved to column x on line y.

A.15. Initialize display

The data in the input buffer will be cleared and reset from default.

A.16. Reset the window

Reset the window on the display.

When s=0, the window is cancelled (values: x1, x2, and y are not required.)

When s=1, the window will be reset (values: x1, x2, and y are required.)

The x1 and x2 set the position of the left column and right column, respectively, of the window.

The y sets the upper line or the lower line of the window.

This function is valid within the horizontal mode.

A.17. Clear display screen and clear string mode

All the display characters will be cleared, and the string mode will be cancelled.

A.18. Clear current line and cancel string mode

The current line is cleared, and the string mode is cancelled.

A.19. Brightness adjustment

Adjust the brightness of the vacuum fluorescent display.

When n=3, brightness=70%

When n=4, brightness=100%

A.20. Set cursor ON or OFF

When n=0, cursor is OFF

When n=1, cursor is ON

9. Control Code Set

HEX	CODE	HEX	CODE
00H	NULL	10H	DLE
01H	SOH, MD1	11H	DC1
02H	STX, MD2	12H	DC2
03H	ETX, MD3	13H	DC3
04H	EOT, MD4	14H	DC4
05H	ENQ, MD5	15H	NAK
06H	ACK, MD6	16H	SYN
07H	BEL, MD7	17H	ETB
08H	BS, MD8	18H	CAN
09H	HT	19H	EM
0AH	LF	1AH	SUB
0BH	VT, HOM	1BH	ESC
0CH	FF, CLR	1CH	FS
0DH	CR	1DH	GS
0EH	SO, SLE1	1EH	RS, SF1
0FH	SI, SLE2	1FH	US, SF2