

MudSling™ R nineT

Installation Guide

machineartmoto

908. 652. 6779

sales@machineartmoto.com

* Before beginning work, read these instructions from start to finish.

* On level ground, place bike on side stand or on center stand.

* MudSling can be installed without removing the rear wheel.

Parts:

- 1 - MudSling R nineT
- 4 - Washers
- 2 - M5 x25mm Torx Screw
- 2 - M5 x10mm Torx Screw
- 2 - M5 Stand-Off

Tools required:

- 10mm Open End Wrench
- T-25 Torx Driver

Additional Tools required for R nineT Standard Models:

- 2mm Allen Wrench/Key
- T-25 Torx Drive Socket and Ratchet Wrench

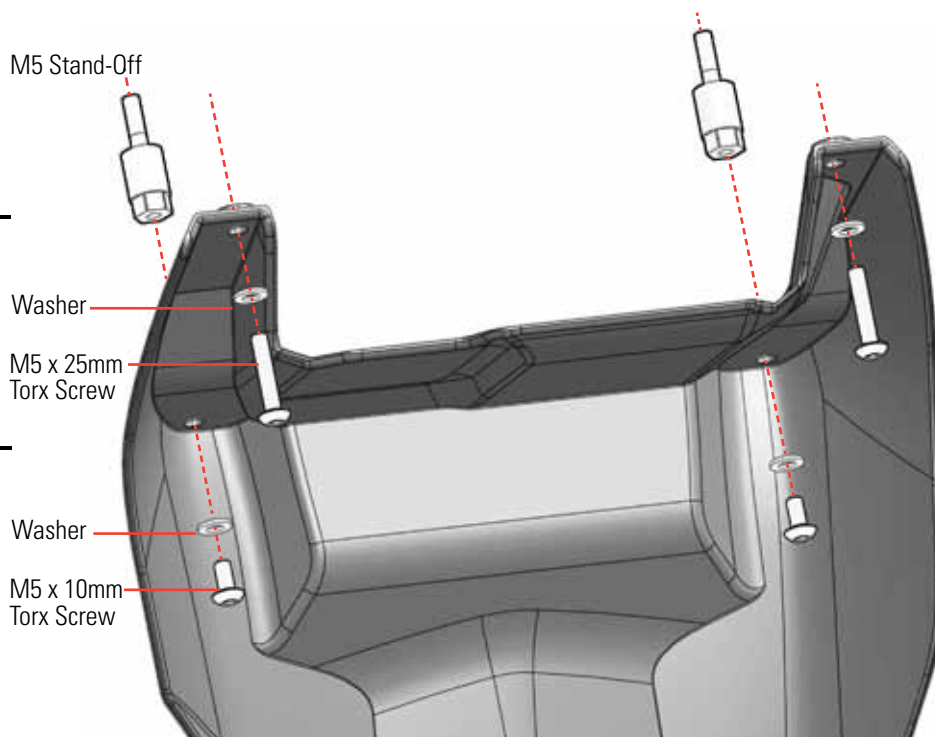

* **NOTE:** Installation differs between the standard R nineT and its variants:

R nineT STANDARD

Begin installation at **Step 1** on page 2. The standard model is equipped with a preload adjuster on the OEM shock. To provide sufficient clearance for the MudSling, the preload body position must be rotated and the adjustment knob removed.

PURE SCRAMBLER URBAN G/S RACER

Begin installation on page 2. No special adjustments are needed.

* Charcoal Canister Differences R nineT Standard Models Only



MudSling **WILL FIT** models with small charcoal cannister - model years 2017~19.

MudSling **WILL NOT FIT** models with large charcoal cannister - model years 2014 ~16.

Note: The size of Charcoal cannisters fitted to North American, European, and Asian models for the model years listed above may differ in your market.

WARNING AND DISCLAIMER: All parts manufactured, designed or sold by Machineart Moto ("MaMo") should be installed by a qualified motorcycle technician. The risk of injury is increased by improper installation or misuse of equipment. MaMo's customers must exercise good judgment in the use, control, alteration, part selection and installation, and maintenance of their motorcycles. In the event of a possible defect in material or design, or any other defect in a part manufactured, designed or sold by MaMo, the responsibility of MaMo is limited to a refund of the purchase price or the replacement of the part if MaMo determines the part to be defective, and subject to MaMo's inspection of the part within thirty (30) days from the date of purchase. (Note: any attempted repairs or modifications made to MaMo products will void this limited warranty). MaMo, under no circumstances will be responsible for incidental and/or consequential damages, property damage, personal injury damage, or damage, injury, cost or expense of any kind or nature whatsoever except as provided by law. MaMo makes no other warranty, express or implied, including without limitation any warranties of merchantability and fitness for a particular purpose.

Begin with Step 1 for R nineT Classic, and certain 2021 models.

Begin with Step 3 for R nineT Pure, Scrambler, Urban GS and Racer.



R nineT standard and certain 2021 models:

Remove the preload adjustment knob. To break the grip of Loctite, use a Ratchet Wrench with a T25 Torx driver. Hold knob securely to prevent it from turning while screw is being removed.

Using a 2mm hex tool, loosen the set screw indicated.

Note: Be careful not to strip the screw. If there is any concern about handling this Step, contact a qualified BMW motorcycle technician.



R nineT standard and certain 2021 models:

Rotate the shock so the knob shaft faces the right hand side of the motorcycle. Using a 2mm hex tool, re-tighten the set screw.

Do not re-install the preload adjustment knob. It will interfere with the brake fluid reservoir. To adjust the shock after installing the MudSling, use an 8mm socket or open end wrench.

Proceed with Step 3.



Remove the four screws indicated using a T-25 torx driver. These screws will not be re-used.



Install the supplied stand offs into the two forward most mounting locations. Tighten using a 10mm wrench.



Position the MudSling forward and low, then lift to align its mounting holes with the Stand-offs and rear mounting holes.



Add a washer to each M5 Torx head screw. Insert an M5 x10 screw through the MudSling and into each stand-off, and an M5 x 25 screw through the rear holes of the MudSling into the frame threads. Tighten all screws with a T25 Torx driver.