

# QUICK START GUIDE



**BRAKE FREE**

**FOR VIDEO TUTORIAL VISIT: BRAKEFREETECH.COM/INSTALL**

**Disclaimer:** Follow all of the installation steps outlined in this guide for best results.

Brake Free is a helmet accessory intended to enhance the user's visibility. It is not intended to replace the required illumination and/or braking indication equipment required for road use of your motorcycle.

TEST FIT ON HELMET MAKING SURE MOUNT IS FLAT AGAINST HELMET FOR MAXIMUM ADHESION

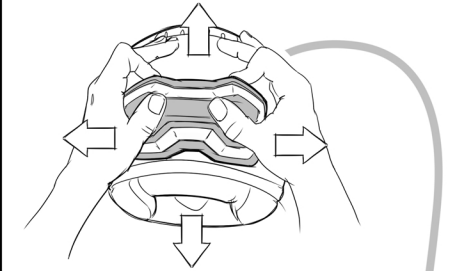

HELMET CURVATURES VARY TOP TO BOTTOM

FIND MAXIMUM CONTACT PATCH FOR MOUNT BY MOVING UP AND DOWN

WIPE DOWN BACK OF HELMET WITH ALCOHOL SWAB SUPPLIED

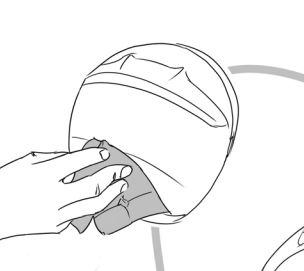

TAPE FITMENT GUIDE ONTO HELMET

REMOVE ADHESIVE BACKING

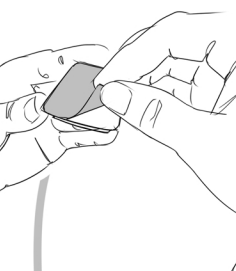

STICK AND PRESS FOR 60 SECONDS

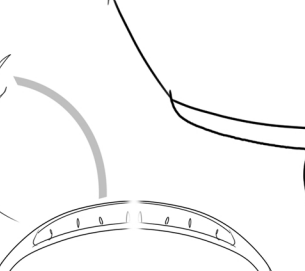

PUSH IN - SLIDE DOWN - CLICK

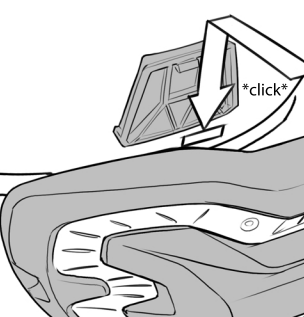

\*click\*

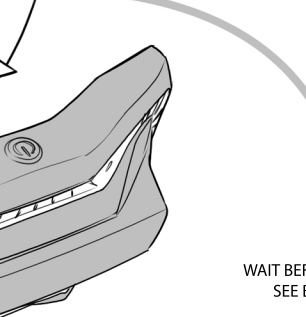

WAIT BEFORE RIDING SEE BELOW!\*



\*After application, the bond strength will increase as the adhesive flows onto the surface. At room temperature, approximately 50% of the ultimate strength will be achieved after 20 minutes, 90% after 24 hours and 100% after 72 hours.

**\*RECOMMENDED: AT LEAST 2 HOURS**

CHARGE INDICATOR LIGHTS



**ON** - QUICK PRESS

**MODE** - QUICK PRESS

**OFF** - HOLD 2 SEC.

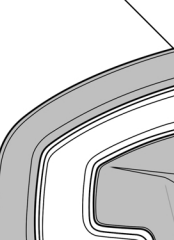

PEEL BACK FLAP FOR MICRO USB CHARGE PORT

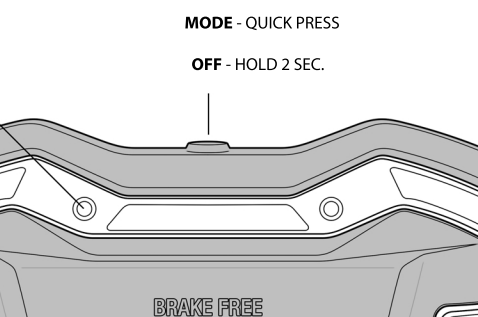

ON STARTUP, THE CENTER BLOCK LIGHTS WILL BLINK TOGETHER TO INDICATE THE CHARGE LEVEL

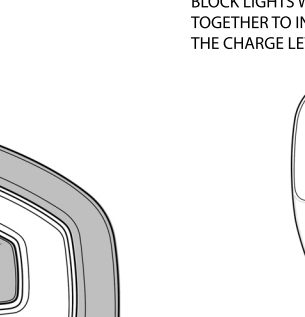

**1 BLINK** < 35% CHARGE

**2 BLINKS** 35 - 75% CHARGE

**3 BLINKS** 75 - 100% CHARGE

**\*\*\*FOR FULL DETAILS SEE USER MANUAL ONLINE - BRAKEFREETECH.COM/MANUAL\*\*\***

**TO PERFORM A HARD RESET** HOLD POWER BUTTON FOR 10 SECONDS, THEN RELEASE.

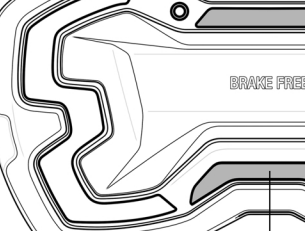

**CAUTION: TALL BACKPACKS** RISK OF UNPLANNED RELEASE IF BACKPACK PRESSES UNIT.



**BRAKE FREE** IS NOT MEANT TO REPLACE YOUR BRAKE LIGHT, PLEASE CHECK YOUR LOCAL LAWS REGARDING BRAKE LIGHT FUNCTION AND REQUIREMENTS.

**BRAKE FREE** IS NOT RESPONSIBLE FOR YOUR SAFETY, WE ARE A LIGHT ACCESSORY MEANT TO IMPROVE YOUR VISIBILITY, BUT YOUR SAFETY IS STILL SOLELY IN YOUR HANDS.

**BRAKE FREE** IS NOT RESPONSIBLE FOR UNINTENTIONAL USAGE

**BRAKE FREE** CONTAINS LITHIUM ION BATTERY

Lithium ion batteries might cause damages like leaking, fire or explosion when misused or defective. Failure to read and follow the below instructions may result in fire, personal injury and damage to property if charged or used improperly or if defective.

Always charge in an isolated area, away from other flammable materials like wood or carpet. Never charge batteries unattended.

Please double check your charger to assure it is operating correctly at the beginning of every charge cycle. If your charger or battery becomes hot, balloons/swells, emits smoke or smells unusual, STOP CHARGING IMMEDIATELY. Observe the battery for 15 minutes in a safe area outside of any building or vehicle and away from any combustible material to assure that it does not ignite, and contact us.

Some micro USB chargers on the market may have technical deficiencies that may cause them to charge Li-ion batteries incorrectly or at an improper rate. It is your responsibility solely to assure the charger you purchased works properly. Always monitor charging process to assure batteries are being charged properly.

Do NOT disassemble or modify the battery. Vibration, puncture, contact with metals, or tampering with the battery can cause it to fail. The battery contains safety and protection devices, which, if damaged, may cause the battery to generate heat, explode, ignite, or short circuit. Severe injury may occur.

Store in a cool, dry place. Never store or charge batteries in extreme temperatures, such as a hot car; near heat sources or fire; or in pressurized or very cold environments.

Keep away from children.

In the event the battery leaks and the fluid gets into one's eye, do not rub the eye. Rinse well with water and immediately seek medical care. If left untreated, the battery fluid could cause damage to the eye.

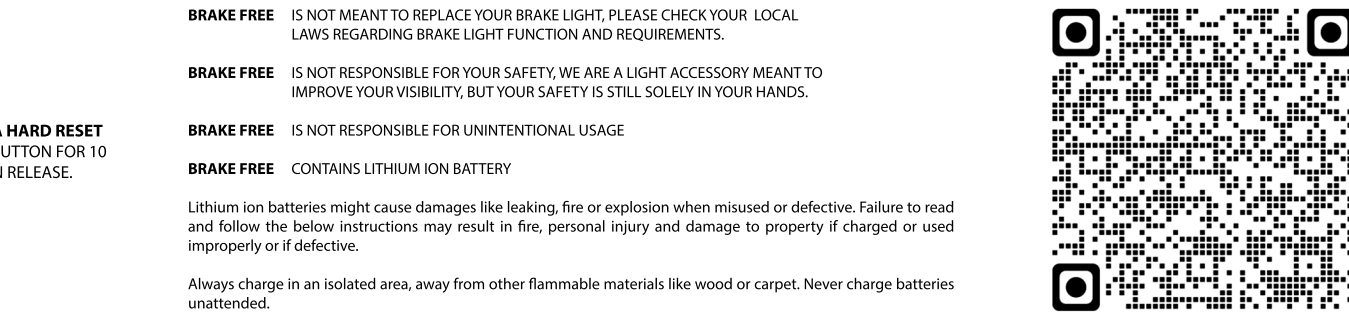

## QUICK START GUIDE

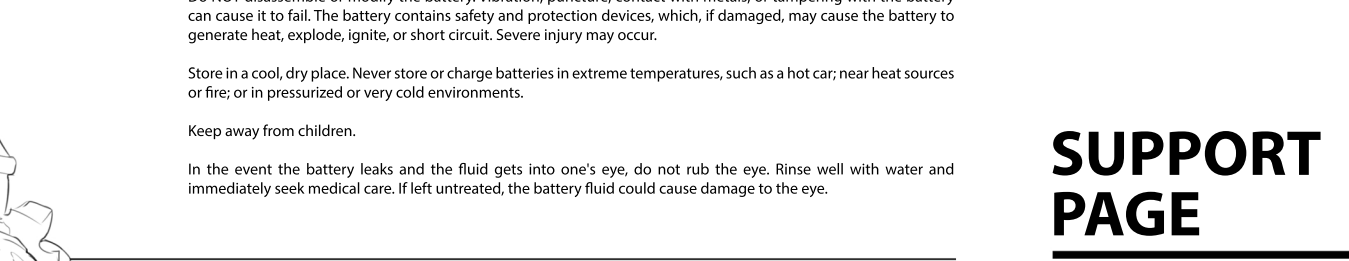

## SUPPORT PAGE