

# Technical Manual, Internal Wall Insulation NBT Refurb System IWI - Pavadry

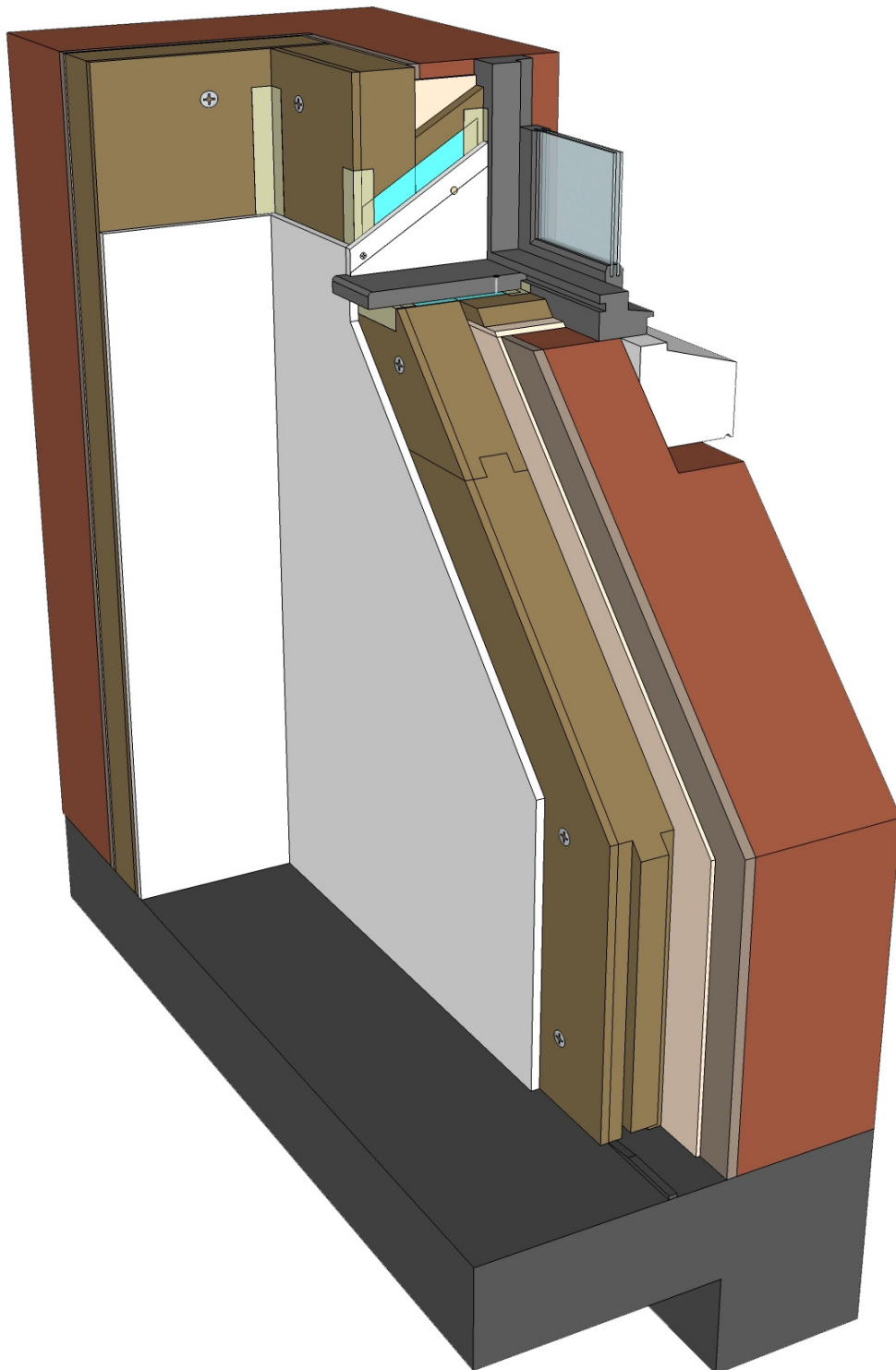

# NBT PAVADRY

## Introduction

### Introduction

Great care needs to be taken in considering options for the thermal upgrading of existing buildings, particularly older 'traditional' buildings constructed using natural materials. The simplest solution, from the point of view of building physics, is to insulate externally. However, changes to the external façade are often not possible due to conservation reasons, access, impact on neighbouring properties or other reasons.

The alternative is internal insulation, but this too can have some disadvantages. In addition to the loss of living space, thermal bridging risks at partition walls or intermediate floor levels must be addressed. Most critically, internal insulation can introduce potential damage to the building fabric due to interstitial moisture including condensation, driven rain, rising damp or other fabric moisture sources. This risk can be reduced considerably by applying a suitable insulation material, appropriate insulation thickness and using accurate modelling software to assess the behaviour of the completed detail.

NBT PAVADRY offers all of this. A unique, fully breathable composite product which combines the proven Pavadentro woodfibre internal insulation board with a dense fibre board. NBT PAVADRY provides simple and quick installation without the need for multiple trades. Standard plasterboard or a gypsum fibre board such as Fermacell (for improved strength) are simply screw-fixed back to the PAVADRY board. For added reassurance, NBT can provide a detailed assessment of the finished construction using a very advanced dynamic moisture assessment program.

Thanks to its vapour permeability and hygroscopic and capillary characteristics, NBT PAVADRY maintains the breathability of the wall and reduces the risk of interstitial condensation, fabric moisture and biological degradation such as mould growth which are common symptoms where conventional internal insulation materials with vapour barriers and non-breathing systems are used. NBT PAVADRY delivers not only an energy efficient, high performance insulation solution, but also ensures a comfortable and healthy internal environment for the building occupants and real protection to the building fabric.

### Advantages overview

- natural product made from wood off-cuts
- breathable: capillary active, hygroscopic and vapour-permeable system
- creates healthy, comfortable living environment
- protects building fabric
- dry breathable wall ensures good thermal performance
- external facade remains visible and unchanged
- dry lining reduces construction time and offers various finish options with or without service void for maximal flexibility
- easy-to-handle board size (1 person) for
- modernisation, refurbishment and conservation projects

### Manufacture and Ecology

NBT PAVADRY SYSTEM meets all ecological requirements from its manufacture to final disposal.

The natural, renewable raw material for NBT PAVADRY boards consists of splinters and wood chips of native softwoods which arise as by-products in local sawmills.

The mineral functional layer consists of natural silicates. The hardboard is produced using only small amounts of formaldehyde-free glue.

The wood's own natural lignin acts as a binder, without the addition of further artificial binding agents.

NBT PAVADRY SYSTEM will remain effective as an insulation material for the life of the building in which it is incorporated.

# NBT PAVADRY

## Build-up

### Build-up

#### Option without service void

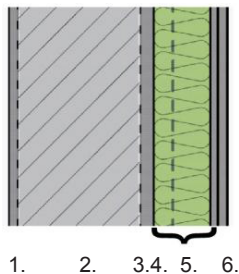

1. External finish (if existing)
2. Block/Brick work
3. Existing plaster or levelling coat (NBT RK 38)
4. Bonding coat (NBT RK 70)
5. NBT PAVADRY
6. Plasterboard, Fermacell board or other lining

#### Option with service void:

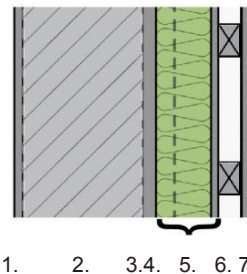

1. External finish (if existing)
2. Block/Brick work
3. Existing plaster or levelling coat (NBT RK 38)
4. Bonding coat (NBT RK 70)
5. NBT PAVADRY
6. service void
7. Plasterboard, Fermacell board or other lining

Bonding coat

NBT PAVADRY

Fixing

Lining (e.g. plasterboard)

Skim (if needed)

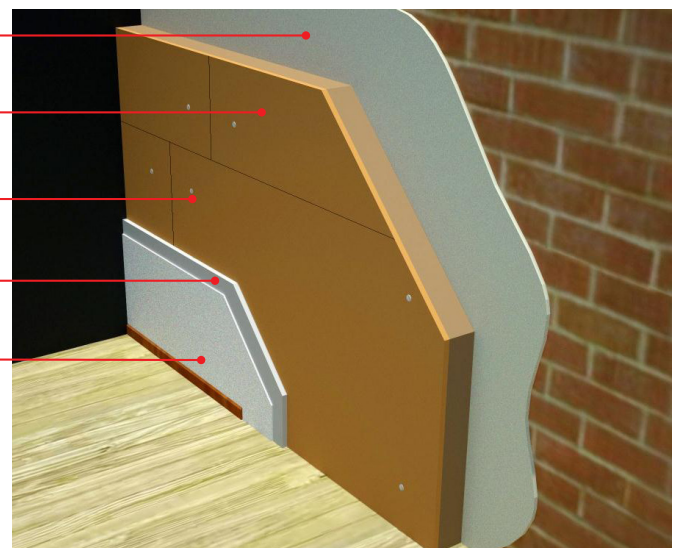

### Advantages of Pavadry

- easy fixing into wall (light objects)
- unrestricted choice of lining (plasterboard, fermacell board or similar, different thicknesses)
- reduced thermal bridging

# NBT PAVADRY

## Principles

### Behaviour of internal insulation systems

#### Conventional insulation with vapour barrier

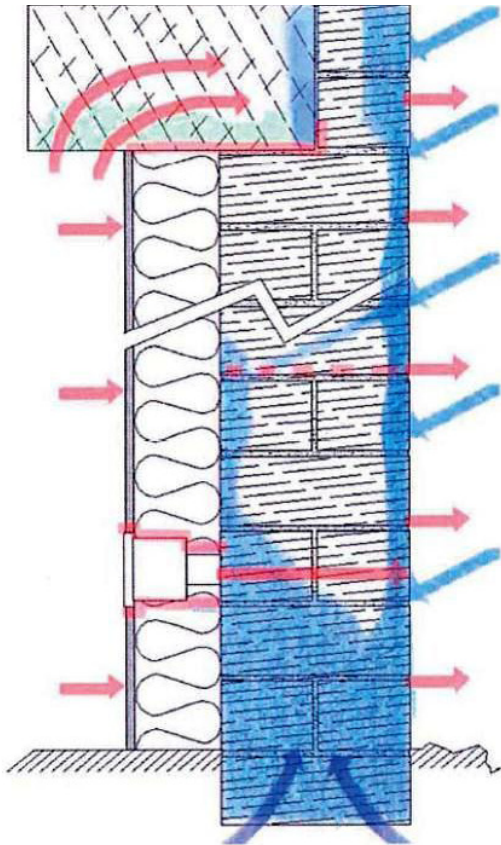

#### Breathable PAVADRY insulation

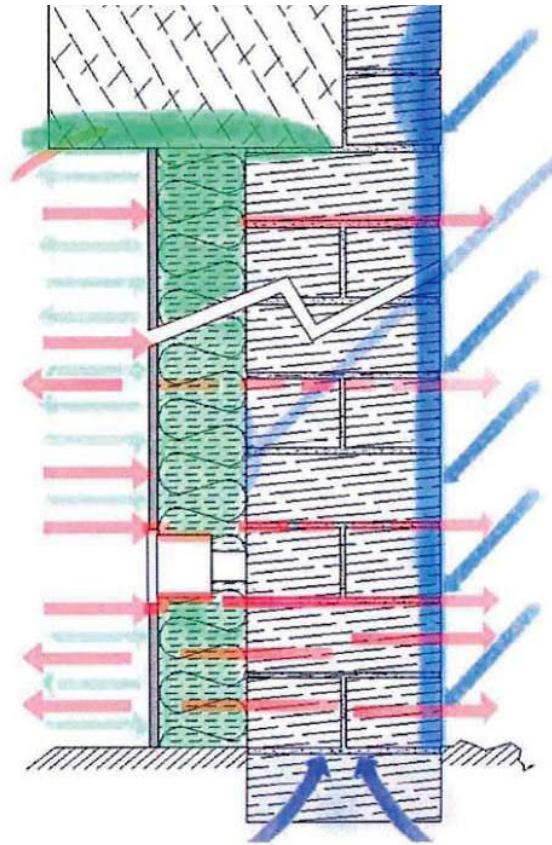

The graphic above shows an external wall with conventional internal insulation on the left side and NBT PAVADRY system on the right side and how each system is affected by moisture. Moisture sourcing from the ground (rising damp), outside (mainly through driven rain) and from the inside (vapour diffusion and convection through leakages) are indicated by different colours. Red arrows show vapour movement, blue arrows show liquid moisture and green indicates moisture storage and buffering.

In a conventional insulated wall, drying out of the wall is reduced to the inside as often a high vapour resistance (vapour barrier) is applied and the materials do not possess capillary or hygroscopic properties. This can lead to higher moisture content within the wall, mould growth and ultimately this could lead to damage to the fabric. The risk is higher around details such as timber joists, services or at ground level.

The risk of excessive moisture can be reduced by the application of a breathable insulation such as NBT PAVADRY. Breathability means that the insulation is vapour open, capillary active and hygroscopic. Thanks to its hygroscopicity and high density NBT PAVADRY can buffer (peak) moisture and release it back to the room which helps to equalize the internal climate. The capillary actions of the material helps to move liquid moisture away from the most critical interface (between insulation and existing wall, where the relative humidity increases due to the lower temperature of the wall). This is why the board must be bonded to the wall and why the density at this point is critical to ensure holding capacity for moisture. The vapour openness allows water vapour to pass through the construction evenly, which reduces the assists drying and avoids moisture becoming trapped within the construction. However, breathable insulation is not the cure for every problem. The wall, gutters, render or french drain need to be in sound condition in order to protect the wall from driven rain.

Natural Building Technologies Ltd

The Hangar, Worminghall Road, Oakley, Buckinghamshire. HP18 9UL

T: 01844 338338 F: 01844 338525

info@natural-building.co.uk www.natural-building.co.uk



# NBT PAVADRY

## Background

### Location

Geographical location and the consequent variations in climate are an important factor affecting how a building will behave. The main variables are:

- precipitation (rain)
- sunshine
- temperature
- relative humidity
- windspeed (closely related to driving rain)
- global radiation

### Example

To demonstrate the effect of those factors, the graph to the right shows the relative humidity at the critical interface of the same construction (9-inch solid brick wall, and 92mm NBT PAVADRY SYSTEM internally) in different locations but from the same orientation, here West.

As can be seen, the relative humidity (RH) is well below the critical value of 85% in London, while the same construction is just at the threshold in Manchester and completely failing in Swansea.

The geographic position is only one aspect in terms of the location. Factors such as orientation (wind driven rain, sunshine) or how exposed or sheltered a house is, can all significantly affect the behaviour of a building (e.g. a nearby building or a large tree will affect the amount of rain and sun getting to the surface of the wall considerably).

This is demonstrated in the second graph, where the same construction is compared in Swansea but with different orientations.

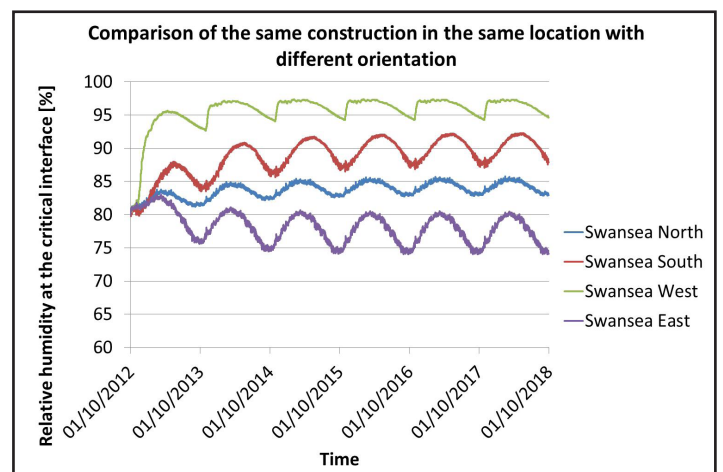
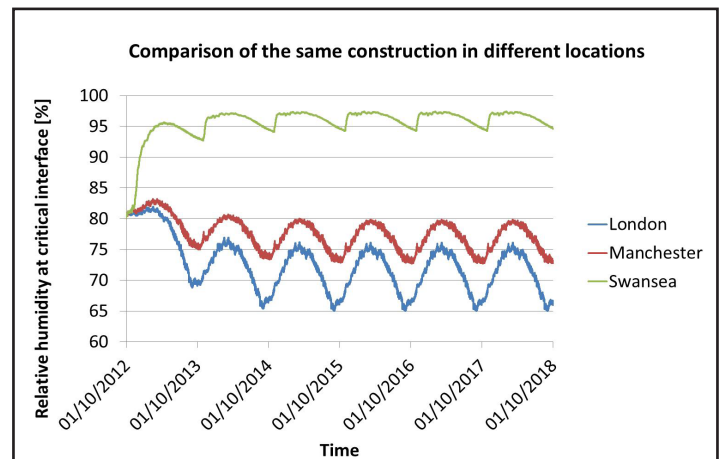

# NBT PAVADRY

## Background

### Thickness of insulation

By fitting internal insulation onto a wall, the temperature of the external wall drops, as the “heating” of the wall through heat loss decreases. The more insulation that is applied internally, the higher the risk that interstitial moisture build up will occur (caused by the lower temperature at the critical interface and by the inability of the wall to move moisture from rain, rising damp etc from the wall to the outside of the building). This however, is not the only point that has to be considered in terms of the insulation thickness. Greater thicknesses will also reduce the living space.

Furthermore, the benefit of applying insulation is not linear to the thickness but decreases with added thickness. The decrease in the benefit is even higher when (unavoidable) thermal bridges (windows, partition walls, intermediate floors, etc.) are taken into account. The more insulation is applied internally, the higher the percentage of heat lost through thermal bridging.

The graph to the right [Schnieders, 2005] shows the reasonable thickness of internal insulation (for a German house;  $\lambda_{\text{insulation}}=0.035\text{W/mK}$ ) being between 40 and 100mm.

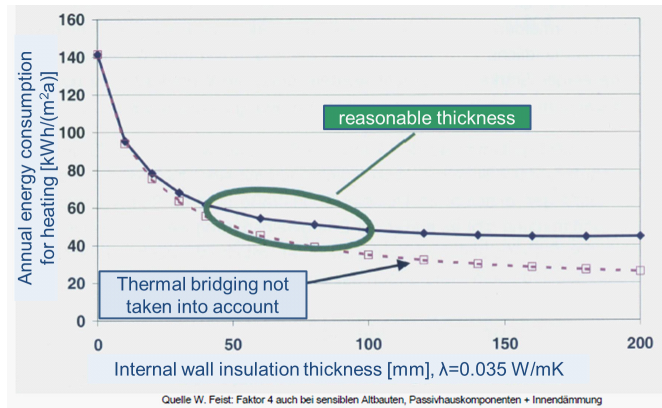

### The advantage of the functional layer

The capillary-active, hygroscopic properties of NBT PAVADRY help to reduce the risk of interstitial condensation.

In addition to this, NBT PAVADRY has an integrated functional layer positioned 20mm from the inner face (against the existing wall). This mineral layer helps to contain the moisture and reduces peak moisture at the most critical interface. As a result of the breathability of the NBT PAVADRY SYSTEM, moisture will later be released to both internal and external environments.

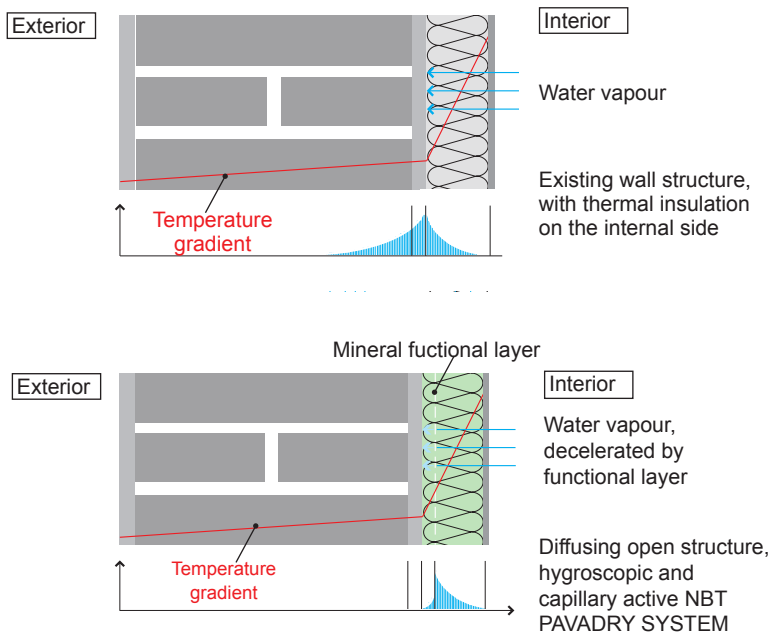

**The outstanding capillary active NBT PAVADRY rapidly absorbs any interstitial condensation and releases it back into the room as water vapour**

Natural Building Technologies Ltd

The Hangar, Worminghall Road, Oakley, Buckinghamshire. HP18 9UL

T: 01844 338338 F: 01844 338525

info@natural-building.co.uk www.natural-building.co.uk

# NBT PAVADRY

## Physical Data

### General

- Traditional wall U-values vary considerably according to material, type, region, age and moisture content. Please see SPAB website and Historic Scotland Technical Papers for further information. Ideally U-Values should be checked on site.
- Due to thermal bridging (see page 6) and the risk of reduced heat flow to traditional buildings it is advisable to limit the amount of insulation to a maximum of 100mm (with a  $\lambda$  of 0.04). Please see STBA Responsible Retrofit of Traditional Building Report ([www.stbauk.org](http://www.stbauk.org)).

### Building Regulations

Please note that according to *Building Regulations Part L1B (2010) requirements for existing dwellings section 5.12* the U-Value threshold for refurbishment can be as high as 0.7 W/m<sup>2</sup>K where it is not possible to achieve 0.3 W/m<sup>2</sup>K „due to technical, functional or economic reasons“.

### Solid masonry (brick/block)

Existing structure [mm]	U-Value before [W/m <sup>2</sup> K]	Thickness NBT PAVADRY SYSTEM [mm]	U-Value after [W/m <sup>2</sup> K] <small>including 12.5mm Plasterboard</small>
215	2.00	52 (40+12)	<b>0.64</b>
215	2.00	72 (60+12)	<b>0.49</b>
215	2.00	92 (80+12)	<b>0.4</b>
215	2.00	112 (100+12)	<b>0.33</b>
300	1.65	52	<b>0.6</b>
300	1.65	72	<b>0.46</b>
300	1.65	92	<b>0.38</b>
300	1.65	112	<b>0.32</b>

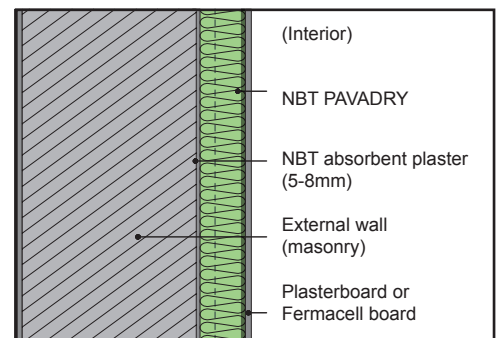

### Brick with 50mm cavity

Existing structure [mm]	U-Value before [W/m <sup>2</sup> K]	Thickness NBT PAVADRY SYSTEM [mm]	U-Value after [W/m <sup>2</sup> K] <small>including 12.5mm Plasterboard</small>
250 *	1.49	52 (40+12)	<b>0.57</b>
250 *	1.49	72 (60+12)	<b>0.45</b>
250 *	1.49	92 (80+12)	<b>0.37</b>
250 *	1.49	112 (60+12)	<b>0.31</b>
250 **	0.62	52	<b>0.38</b>
250 **	0.62	72	<b>0.33</b>
250 **	0.62	92	<b>0.29</b>
250 **	0.62	112	<b>0.25</b>

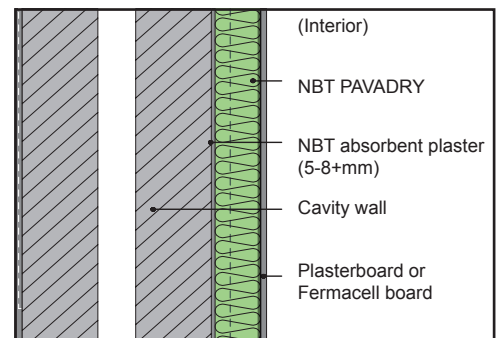

\* Cavity not insulated    \*\* Cavity filled with EPS ( $\lambda=0.04$ W/mK)

### Natural stone\*

Existing structure [mm]	U-Value before [W/m <sup>2</sup> K]	Thickness NBT PAVADRY SYSTEM [mm]	U-Value after [W/m <sup>2</sup> K] <small>including 12.5mm Plasterboard</small>
350	1.94	52 (40+12)	<b>0.62</b>
350	1.94	72 (60+12)	<b>0.48</b>
450	1.65	92 (80+12)	<b>0.39</b>
450	1.65	112 (100+12)	<b>0.33</b>
450	1.65	52	<b>0.59</b>
350	1.94	72	<b>0.46</b>
450	1.65	92	<b>0.38</b>
450	1.65	112	<b>0.32</b>

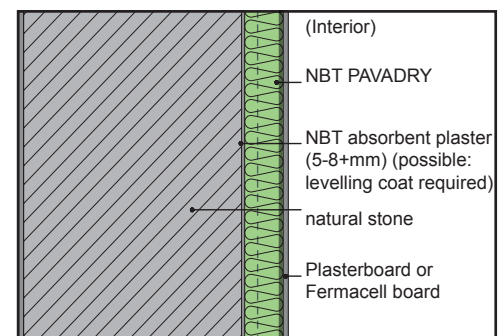

\*  $\lambda=1.1$  W/mK

# NBT PAVADRY

## Installation

### Pre-Installation

1. Survey building for problem areas that need addressing prior to application and eliminate the causes (e.g. replace leaking gutters, repoint wall areas that do not provide sufficient protection against driven rain, create french drain to ensure that water can run off, etc).
2. Check that the actual wall build-up in reality is what has been modelled during the design and specification. Make any adjustments as necessary. Please contact NBT for further information.

### Build-up

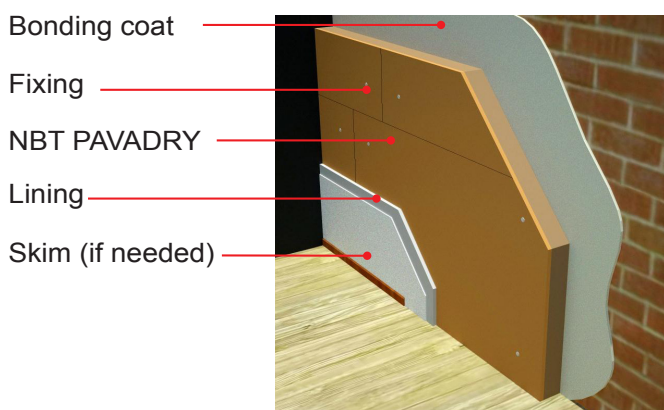

### Installation

1. NBT PAVADRY SYSTEM is applied on an even, dry surface. A dubbing out/parge coat (RK 38) is required for walls where internal plaster has been removed or is blown, walls with sharp indentations deeper than 5mm, or walls with deviation greater than 3mm over 1.3m. Flat walls without indentations are required to eliminate air gaps behind the boards. Levelling/plumb requirement should be determined in consultation with client/architect. To achieve effective airtightness with the parge coat, 8mm thickness is required
2. A bonding mortar (NBT RK70) 4-5mm is applied to adhere the NBT PAVADRY to the wall. This helps to eliminate airgaps and reduces the quantity of fixings required to secure the system to the substrate. The bonding coat can be applied either onto the wall or onto the woodfibre boards directly.
3. In addition to the bonding coat mechanical fixings are required.
  - type of fixing: Mungo MRS-U, 7.5mm diameter
  - quantity of fixings: three per board
  - length of fixings: 40mm minimum embedment into substrate
  - pre-drill through NBT PAVADRY and masonry, diameter: 6mm
  - no wall plug required
4. Where a service void is to be provided: battens to form the service void are fixed. The battens can be fixed to the outer face of Pavadry, but should be fixed back into the substrate for heavy loads.
5. Dry lining board is fixed (e.g. gypsum plasterboard).
  - lining can only be secured into the outer layer of NBT Pavadry (or into the battens, if service void

### Post-Installation

1. Where potential risks have been identified ensure that adequate checks or monitoring are put in place. Please contact NBT for further advice.

Natural Building Technologies Ltd

The Hangar, Worminghall Road, Oakley, Buckinghamshire. HP18 9UL

T: 01844 338338 F: 01844 338525

info@natural-building.co.uk www.natural-building.co.uk



# NBT PAVADRY

## Installation: How to deal with .....

### Services

Wherever possible we recommend running services on the internal walls. Where this is not possible, a service void can be applied onto the hardboard to accommodate services. Alternatively, services can be chased into the board (keep penetrations of the functional layer to a minimum (functional layer is located 20mm from the back of the board for all thicknesses)).

### Objects fixed into the wall

Lighter objects can be fixed through the lining into the hardboard. For additional strength a gypsum fibre board such as Fermacell can be applied instead of a standard plasterboard.

Heavy objects must be fixed back into the substrate. To reduce the risk of surface mould growth where the fixing creates a thermal bridge, we recommend thermally broken fixings such as FISCHER THERMAX.

### Cutting

The NBT PAVADRY SYSTEM can be cut easily with a circular or hand saw.

### Existing plaster

Ideally (or where the application of internal insulation is critical e.g. due to challenging location), NBT recommends removing existing plaster. This is due to the fact that some plasters are not very breathable (e.g. dense cement plaster) or cannot deal as well with moisture (gypsum). However, providing that moisture levels remain low enough, it is possible to leave the existing plaster in situ. Please contact NBT for advice and moisture modelling.

### Existing vapour closed surfaces

Vapour closed surfaces need to be removed or (e.g. in the case of paint) opened up mechanically.

### Airtightness

Airtightness should be provided as one continuous uninterrupted layer. For the NBT PAVADRY SYSTEM the layer of airtightness can be either at the back (bonding coat) or in front (hardboard). For the latter the joints have to be taped. For both options penetrations, corners, windows or similar have to be taped adequately.

### Wet areas

NBT PAVADRY SYSTEM is not suitable for areas with a moisture problem caused by rising damp, failing gutters, or where the outer facade cannot provide sufficient protection against driven rain.

NBT PAVADRY SYSTEM can be used in domestic kitchens and, with limitations, in bathrooms.

For bathrooms an effective extractor fan is required and NBT Pavadry is not suitable where tiling is applied onto external walls.

Please contact NBT for further advice.

### Covering

Non-breathable materials such as tiles, metal sheeting or non-breathable paint should not be applied onto NBT PAVADRY SYSTEM.

### Timber joists

If access to the timber joist is possible, NBT recommends eliminating the thermal bridge by applying insulation between the joists (e.g. NBT PAVAFLEX).

It is very important to achieve good levels of airtightness around the joists, either with NBT airtightness tapes or with plaster, before installing this insulation.

# NBT PAVADRY

## Key considerations

### Suitable buildings:

The existing wall should be vapour open (i.e. is not finished with hard cement renders or vapour closed paints - emulsions are ok - contact NBT if in doubt.). NBT PAVADRY is suitable for:

- Solid masonry (brick/block)
- Cavity wall
- Timber frame with brick infill
- Natural stone\*

\* Depending on thickness of insulation and type of stone

### Thickness of insulation:

For insulation boards of different thicknesses the difference should not be more than 20 mm

### Integrated partition walls

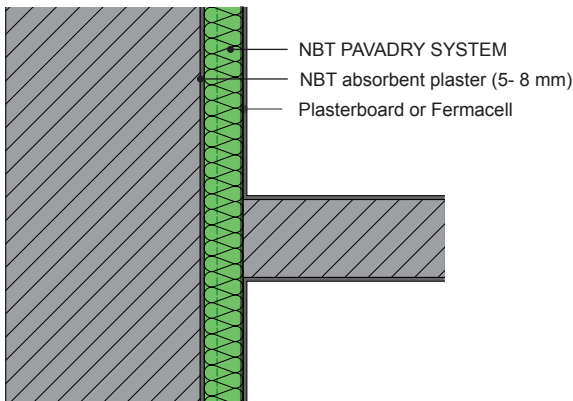

Non structural solid building elements can be separated at the external element to allow continuous insulation on the external element surface

### Insulation covering two storeys

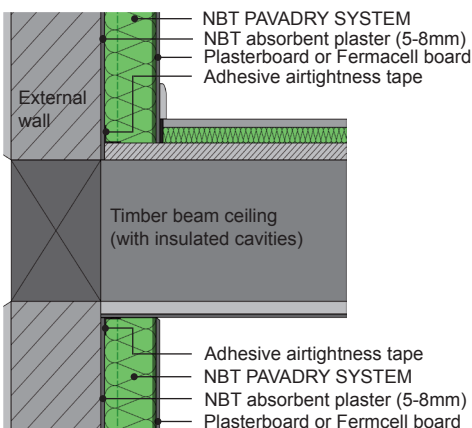

### Installation criteria:

- Insulation for dry areas only (not suitable for rooms with constantly high humidity)
- External wall must provide sufficient protection against driving rain
- No rising damp within the structural element
- No application below DPC level
- Only above ground level

### Integrated load-bearing walls

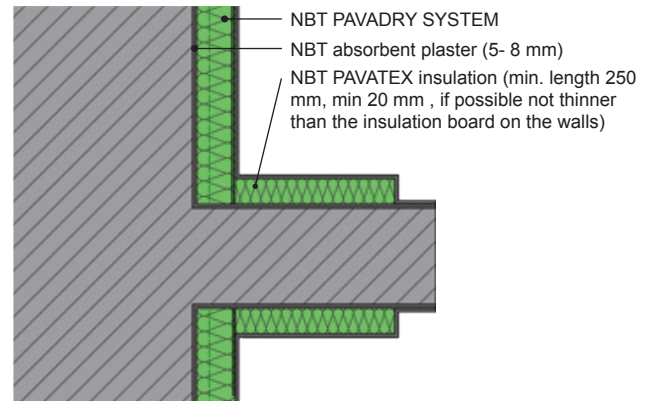

NBT recommends that integrated solid building elements, which cannot be separated from the external wall should be insulated with NBT DIFFUTHERM reveal boards or NBT PAVADENTRO.

### WRONG!

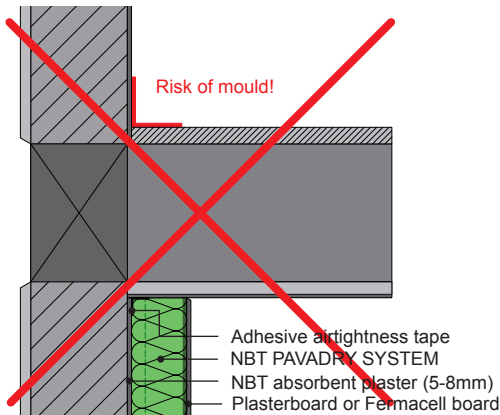

**Partially installed internal insulations** increase the risk of mould formation (see also “irb-report” F2454) and should be avoided. If possible always install room-side insulation on both sides of the dividing structural element.

Natural Building Technologies Ltd

The Hangar, Worminghall Road, Oakley, Buckinghamshire. HP18 9UL

T: 01844 338338 F: 01844 338525

info@natural-building.co.uk www.natural-building.co.uk

## Window

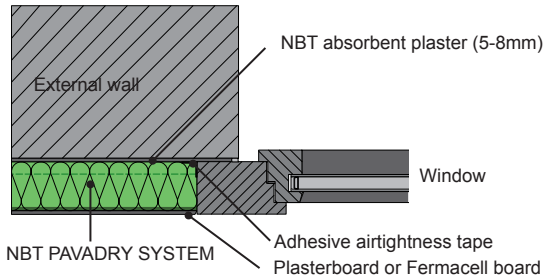

The window frame may be fixed flush with the inside of the existing wall to reduce thermal bridging in the reveal. However where this is not possible the reveals need to be insulated. Obviously, the more insulation is applied at the reveals, the smaller the heat loss through this junction. But as space is often limited, insulating the reveals with more than 20mm is often not possible. If no insulation is applied, the risk of mould is very high as the area is much colder at this thermal bridge. NBT recommends a minimum insulation thickness is 20mm. Where this is not possible, please contact NBT for further advice. For all details, a high level of airtightness needs to be achieved to avoid problems.

## Reveal

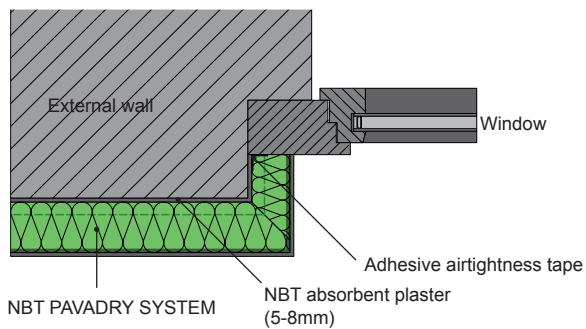

## WRONG!

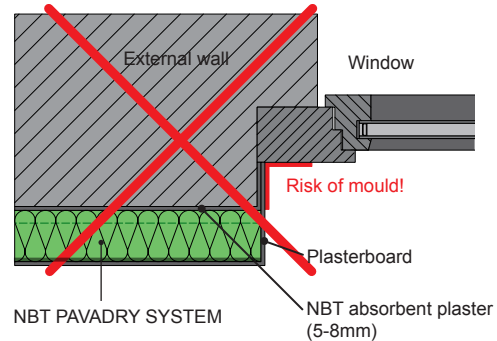

## Joints for external and internal corners

To be butt-jointed and tight fitted.

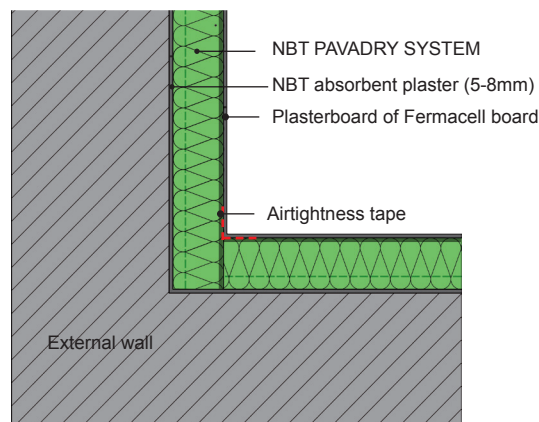

The insulation method shown above (inside corner) should also be applied correspondingly for an external corner

# NBT PAVADRY

## Product Characteristics

### Delivery Form

Properties	Unit	Value
Board thickness (12mm hardboard + Pavadentro)	mm	52, 72, 92, 112*
Size	mm	600 x 1020
Edges	-	tongue and grooved

\* 112mm is subject to longer delivery times and square edged

### Technical Data

Properties	Unit	Value
Density $\rho$ (Pavadentro/Hardboard)	kg/m <sup>3</sup>	180 / 700
Thermal conductivity $\lambda$ (Pavadentro/Hardboard)	W/(mK)	0.042 / 0.14
Compression strength at 10 % compression (Pavadentro)	N/mm <sup>2</sup>	$\geq 0.07$
Tensile strength	N/mm <sup>2</sup>	$\geq 0.005$
Specific heat capacity $c$ (Pavadentro/Hardboard)	J/(kgK)	2100 / 1700
Flow resistance per unit length	kPa s/m <sup>3</sup>	$\geq 100$
Euroclass fire rating according to EN 13 501-1 (Pavadentro)	Class	E
water vapour diffusion resistance factor ( $\mu$ -Value) (Pavadentro/Hardboard)	-	5 / 12
Pull-out resistance perpendicular to surface (without lining) (4mm/5mm screw)	kN	ca. 1.0 / 1.2



# NBT PAVADRY

## Components

Product	Use	Details	Picture
NBT PAVADRY boards	Internal insulation for solid walls.	<ul style="list-style-type: none"> <li>tongue and grooved</li> <li>thicknesses: 52mm, 72mm, 92mm</li> </ul>	
Mungo MRS-U	For fixing the NBT PAVADRY SYSTEM into the substrate.	<ul style="list-style-type: none"> <li>minimum embedment into masonry 40mm</li> <li>Box of 100</li> <li>7.5mm diameter</li> </ul>	
Dry wall screws	For fixing the lining into the hardboard of the NBT PAVADRY SYSTEM.	<ul style="list-style-type: none"> <li>3.5 * 32mm (for 12.5mm Plasterboard);</li> <li>Box of 1000</li> </ul>	
FISCHER THERMAX 8 and 10	For fixing heavy objects to the wall	<ul style="list-style-type: none"> <li>thermally broken</li> <li>Box of 20</li> <li>8 or 10mm diameter</li> </ul>	
NBT BAUMIT RK38	Levelling plaster to straighten uneven walls; up to a maximum thickness of 25mm	<ul style="list-style-type: none"> <li>Bag of 25kg</li> </ul>	
NBT BAUMIT RK70	Adhesive plaster to adhere NBT PAVADRY SYSTEM onto substrate; Thickness 5-8mm	<ul style="list-style-type: none"> <li>Bag of 25kg</li> </ul>	
NBT PAVATEX Pavafix	Tape to achieve airtightness	<ul style="list-style-type: none"> <li>Rolls of different sizes and lengths</li> </ul>	
PAVATEX JIGSAW BLADE	Jigsaw blades for accurate cuts in the woodfibre boards (up to 120mm thickness)	<ul style="list-style-type: none"> <li>3 per pack</li> <li>length 150mm</li> </ul>	

# For your notes & sketches

# NBT Product Overview: Insulation

## ISOLAIR sarking board



PAVATEX wood fibre board for breathable roof & wall constructions

Size: 770 x 2500 mm  
 Cover area: 750 x 2480 mm  
 Thicknesses: 22, 35 & 60 mm  
 k-value / I<sub>D</sub>: 0.047 W/(mK)  
 Density: 240 kg/m<sup>3</sup>  
 Compr. strength: 180 kPa (at 10 % compression)

## PAVATEX DIFFUTHERM external wall insulation



Wood fibre board for rendered external walls

Size: 790 x 1300 mm  
 Cover: 780 x 1290 mm  
 Thicknesses: 60, 80 & 100 mm  
 k-value / I<sub>D</sub>: 0.043 W/(mK)  
 Density: 190 kg/m<sup>3</sup>  
 Compr. strength: 80 kPa (at 10 % compression)

## PAVATHERM-PLUS sarking board



Composite wood board for roof & wall insulation

Size: 800 x 1600 mm  
 Cover area: 780 x 1580 mm  
 Thicknesses: 60, 80 & 100 mm  
 k-value / I<sub>D</sub>: 0.043 W/(mK)  
 Density: 180 kg/m<sup>3</sup>  
 Compr. strength: 100 kPa (at 10 % compression)

## PAVADENTRO internal wall insulation



Innovative wood fibre insulation board for refurbishment

Size: 600 x 1020 mm  
 Cover area: 590 x 1010 mm  
 Thicknesses: 40, 60, 80 & 100 mm  
 k-value / I<sub>D</sub>: 0.043 W/(mK)  
 Density: 175 kg/m<sup>3</sup>  
 Compr. strength: 70 kPa (at 10 % compression)

## PAVATHERM general purpose insulation board



Universal wood fibre board for use in external & internal walls, floors & roofs

Sizes/Cover: 600 x 1020 & 1200 x 2050 mm  
 Thicknesses: 20 -100 mm  
 k-value / I<sub>D</sub>: 0.038 W/(mK)  
 Density: 140 kg/m<sup>3</sup>  
 Compr. strength: 20 kPa (at 10 % compression)

## PAVABOARD load bearing insulation



Wood fibre board for highly insulated floors that have to carry loads

Size/Cover: 600 x 1020 mm  
 Thicknesses: 40 & 60 mm  
 k-value / I<sub>D</sub>: 0.046 W/(mK)  
 Density: 220 kg/m<sup>3</sup>  
 Compr. strength: 150 kPa (at 10 % compression)

## PAVATHERM-PROFIL wall & floor board



Wood fibre board for insulating floors or internal walls with plaster

Size: 600 x 1020 cm  
 Cover: 590 x 1010 mm  
 Thicknesses: 40 & 60 mm  
 k-value / I<sub>D</sub>: 0.043 W/(mK)  
 Density: 175 kg/m<sup>3</sup>  
 Compr. strength: 70 kPa (at 10 % compression)

## NBT PAVATHERM-FORTE



Square edged woodfibre boards for flat roof insulation

Size/Cover: 600 x 1020 mm  
 Thicknesses: 80, 100, 120, 140 mm  
 k-value / I<sub>D</sub>: 0.043 W/(mK)  
 Density: 175 kg/m<sup>3</sup>  
 Compr. strength: 70 kPa (at 10 % compression)

## NBT Pavaflex



Flexible woodfibre insulation batts for loft, walls, floors & ceilings

Size I: 375 x 1350 mm  
 Size II: 575 x 1350 mm  
 Thicknesses: 50, 80, 100 & 140 mm  
 k-value / I<sub>D</sub>: 0.038 W/(mK)  
 Density: 55 kg/m<sup>3</sup>  
 Compr. strength: -

## NBT Warmcel 100 cellulose fibres



Loose fill derived from waste UK newsprint treated with fire retardant and biocidal additives

Packaging: Bags of 8 kg (compressed)  
 Cover area: e.g. 1 m<sup>2</sup> at 228 mm  
 k-value / I<sub>D</sub>: 0.035 W/(mK)  
 Density: 35 kg/m<sup>3</sup>

ISOLAIR L, all PAVATHERM products, PAVATEX DIFFUTHERM are certified by natureplus. This testifies to excellent natural & ecological compatibility. PAVATEX wood fibre insulation boards are manufactured in Switzerland according to BS EN 13171, have the CE marking and are monitored by 3<sup>rd</sup> parties. NBT Warmcel 100 is manufactured in the UK according to prEN 15101 & has the CE marking. The following applies to all PAVATEX products: Specific heat capacity c = 2100 kJ/(kg·K), Euroclass E (according to BS EN 13501-1), vapour resistivity m = 5 (25 MNs/gm) The following applies to NBT Warmcel 100: Specific heat capacity c = 1700 kJ/(kg·K), Euroclass E (according to BS EN 13501-1), vapour resistivity m = 1.86 (9.3 MNs/gm)



Natural  
Building  
Technologies



# Natural Building Materials and Systems



**high performance systems** NBT PAVATEX woodfibre systems provide exceptional thermal & acoustic insulation, summer overheating protection and moisture control for the whole building in wall, roof and floor



**low carbon, renewable products** NBT PAVATEX boards are made of waste wood are carbon negative in a whole life cycle analysis. Raw material resources are entirely renewable, unlimited and FSC certified



**healthy housing** NBT PAVATEX insulation boards are certified by natureplus as non-polluting and NBT systems lead to breathable constructions; NBT PAVATEX insulation is specified exclusively by the Sentinal Haus Institute for healthy housing



**tried & tested systems** NBT PAVATEX woodfibre insulation is widely used across Europe in all climates and conditions; physical values are 3rd party tested and guaranteed and production is according to BS EN 13171.



**local service & support** Pavatex's partner in the UK is Natural Building Technologies (NBT), a Technical Sales Company with nationwide coverage based in Oakley, Bucks. NBT leads the UK sustainable materials & systems for high performance building shells



Swiss Made

**swiss quality & know-how for the UK** produced and developed in Switzerland for more than 70 years by the world's most innovative woodfibre insulation manufacturer

Natural Building Technologies Ltd

The Hangar, Worminghall Road, Oakley, Buckinghamshire. HP18 9UL

T: 01844 338338 F: 01844 338525

info@natural-building.co.uk www.natural-building.co.uk

Subject to alteration due to development - Nov. 2013 - US